

#### General Description

100mA negative LDO in SOT-23 package.

This CMOS device regulates a negative supply down to a fixed voltage level at  $\pm 2\%$  accuracy.

It offers exceptional LDO performance of 120mV dropout at 50mA current levels.

The device also comes in a 3-lead SOT-89 package, for a number of voltage and current offerings.

#### Features

- All-CMOS design in SOT-23 and SOT-89 packages gives optimal size and power performance
- $\pm 2\%$  precision outputs
- $3\mu\text{A}$  of  $I_q$
- Package and Voltage options allow:

100mA-5V Regulator  
50mA-3V Regulator  
100mA-5V to -3V Converter  
50mA-5V to -3V Converter

#### Applications

- Battery-powered Equipment
- Reference voltage sources
- Portable Cameras and Video Recorders
- Power Failure Detection
- PDAs

#### Block Diagram

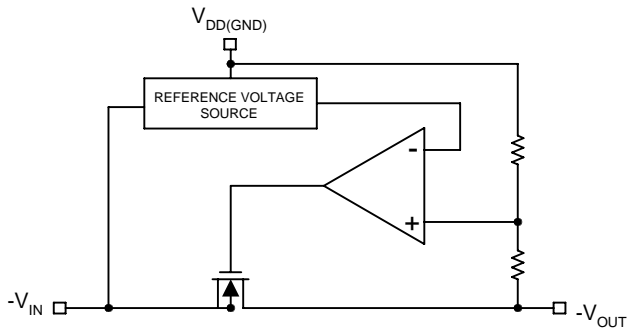

#### Ordering Information

ILC7362CP-50	100mA-5V Regulator SOT-89 Package
ILC7362CP-30	100mA-5V to -3V Converter, or 50mA-5V Regulator SOT-89 Package
ILC7362CM-30	50mA-5V to -3V Converter SOT-23 Package

\*Standard product offering comes in tape & reel, quantity 3000 per reel, orientation right for SOT-23, quantity 1000 per reel, orientation right for SOT-89.

#### Pin-Package Configurations

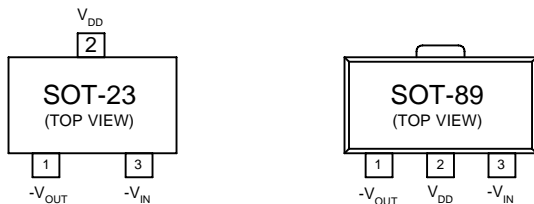

**Absolute Maximum Ratings (T<sub>A</sub> = 25°C)**

Parameter	Symbol	Ratings	Units
Input Voltage	V <sub>IN</sub>	-12	V
Output Current	I <sub>OUT</sub>	200	mA
Output Voltage	V <sub>OUT</sub>	-V <sub>DD</sub> -0.3~V <sub>IN</sub> +0.3	V
Continuous Total Power Dissipation	SOT-23	P <sub>D</sub>	150
	SOT-89		500
Operating Ambient Temperature	T <sub>opr</sub>	-30~+85	°C
Storage Temperature	T <sub>stg</sub>	-40~+125	°C

**Electrical Characteristics ILC7362CP-50**

Parameter	Symbol	Conditions	Min	Typ	Max	Units
Output Voltage	V <sub>OUT</sub>	I <sub>OUT</sub> = 20mA, V <sub>IN</sub> = -7.0V	-4.90	-5.0	-5.10	V
Maximum Output Current	I <sub>OUTmax</sub>	V <sub>IN</sub> = -7.0V, V <sub>OUT</sub> ≥ -4.5V	100			mA
Load Stability	ΔV <sub>OUT</sub>	V <sub>IN</sub> = -7.0V, 1mA ≤ I <sub>OUT</sub> ≤ 50mA		40	80	mV
Input/Output Voltage Differential	V <sub>dif</sub>	I <sub>OUT</sub> = 50mA I <sub>OUT</sub> = 100mA		120 380	300 600	mV
Supply Current	I <sub>SS</sub>	V <sub>IN</sub> = 7.0V		3.0	7.0	μA
Input Stability	$\frac{\Delta V_{OUT}}{\Delta V_{IN} \cdot V_{OUT}}$	I <sub>OUT</sub> = 20mA -7.0 ≤ V <sub>IN</sub> ≤ -10.0V		0.1	0.3	%/V
Input Voltage	V <sub>IN</sub>				10.0	V
Output Voltage Temperature Characteristics	$\frac{\Delta V_{OUT}}{\Delta T_{opr} \cdot V_{OUT}}$	I <sub>OUT</sub> = 20mA -30°C ≤ T <sub>opr</sub> ≤ 80°C		±100		ppm/°C

Note:

1. V<sub>OUT</sub> means the output voltage when “V<sub>OUT</sub>-2.0V” is provided at the V<sub>IN</sub> pin while maintaining a certain I<sub>OUT</sub> value.
2. V<sub>dif</sub> is defined as “|V<sub>IN</sub>| - |V<sub>OUT</sub>| .”
3. I<sub>OUTmax</sub> = This is specified for SOT-89 package. For SOT-23, it is limited by continuous total power dissipation.

## Electrical Characteristics ILC7362CP-30

Parameter	Symbol	Conditions	Min	Typ	Max	Units
Output Voltage	$V_{OUT}$	$I_{OUT} = 20\text{mA}$ , $V_{IN} = -5.0\text{V}$	-2.92	-3.0	-3.06	V
Maximum Output Current	$I_{OUT (MAX)}$	$V_{IN} = -5.0\text{V}$ , $V_{OUT} \geq -2.7\text{V}$	100			mA
Load Stability	$\Delta V_{OUT}$	$V_{IN} = -5.0\text{V}$ , $1\text{mA} \leq I_{OUT} \leq 40\text{mA}$		40	80	mV
Input/Output Voltage Differential	$V_{dif}$	$I_{OUT} = 40\text{mA}$ $I_{OUT} = 80\text{mA}$		120 380	300 600	mV
Supply Current	$I_{SS}$	$V_{IN} = -5.0\text{V}$		2.5	6.0	$\mu\text{A}$
Input Stability	$\frac{\Delta V_{OUT}}{\Delta V_{IN} \cdot V_{OUT}}$	$I_{OUT} = 20\text{mA}$ $-5.0\text{V} \leq V_{IN} \leq -10.0\text{V}$		0.1	0.3	%/V
Input Voltage	$V_{IN}$				-10.0	V
Output Voltage Temperature Characteristics	$\frac{\Delta V_{OUT}}{\Delta T_{opr} \cdot V_{OUT}}$	$I_{OUT} = 20\text{mA}$ $-30^{\circ}\text{C} \leq T_{opr} \leq 80^{\circ}\text{C}$		$\pm 100$		ppm/ $^{\circ}\text{C}$

Typical Performance Characteristics *General conditions for all curves; 4.7µF on output*

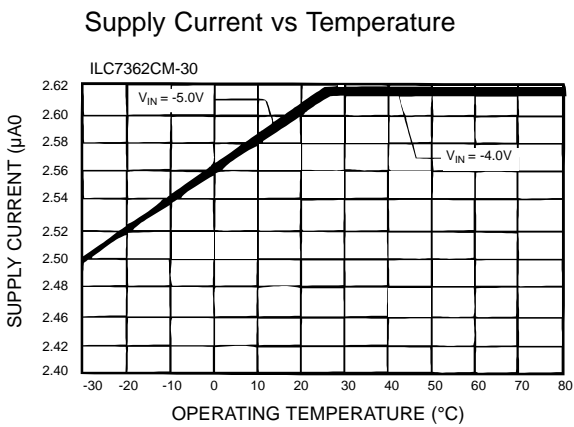
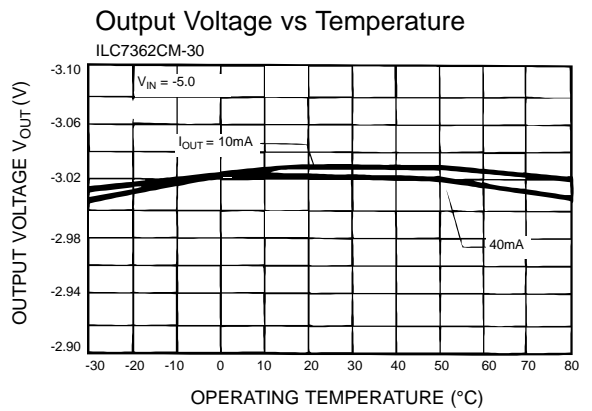
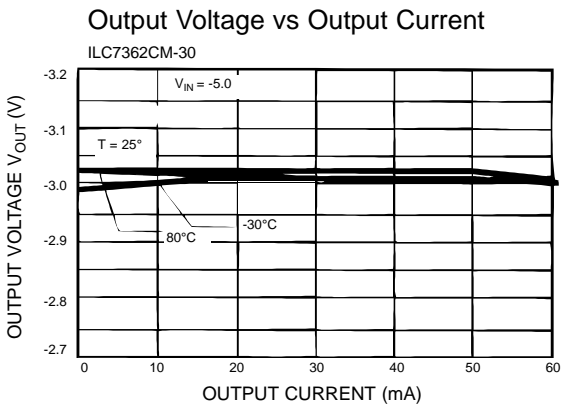
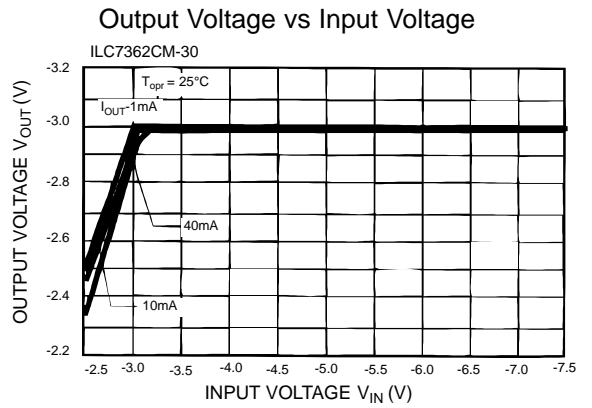
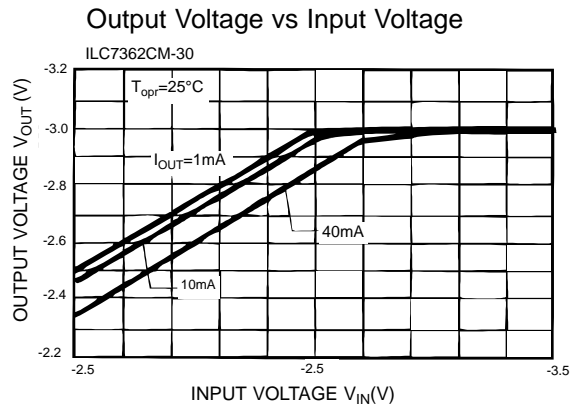

Packaging Information

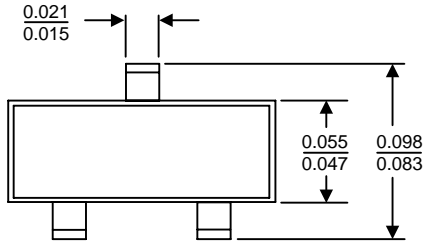

**SOT-23**  
All dimensions in inches

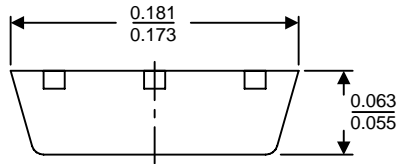
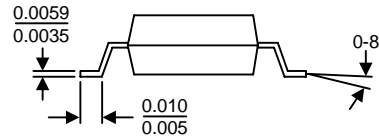
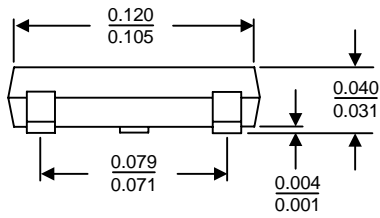

**SOT-89**  
All dimensions in inches

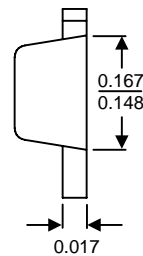
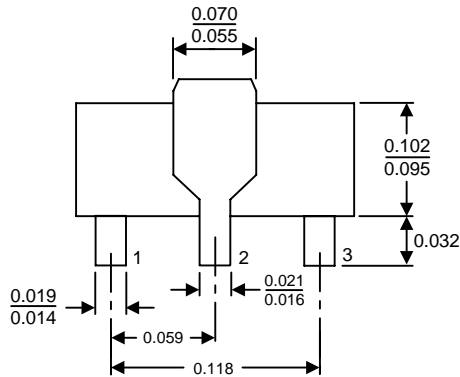

Devices sold by Impala Linear Corporation are covered by the warranty and patent indemnification provisions appearing in its Terms of Sale only. Impala Linear Corporation makes no warranty, express, statutory, implied, or by description regarding the information set forth herein or regarding the freedom of the described devices from patent infringement. Impala Linear Corporation makes no warranty of merchantability or fitness for any purpose. Impala Linear Corporation reserves the right to discontinue production and change specifications and prices at any time and without notice.

This product is intended for use in normal commercial applications. Applications requiring an extended temperature range, unusual environmental requirements, or high reliability applications, such as military and aerospace, are specifically not recommended without additional processing by Impala Linear Corporation.

Impala Linear Corporation assumes no responsibility for the use of any circuitry other than circuitry embodied in an Impala Linear Corporation product. No other circuits, patents, licenses are implied.

**Life Support Policy**

Impala Linear Corporation's products are not authorized for use as critical components in life support devices or systems.

1. Life support devices or systems are devices or systems which, (a) are intended for surgical implant into the body, or (b) support or sustain life, and whose failure to perform, when properly used in accordance with instructions for use provided in the labelling, can be reasonably expected to result in a significant injury to the user.
2. A critical component is any component of a life support device or system whose failure to perform can be reasonably expected to cause the failure of the life support device or system, or to affect its safety or effectiveness.