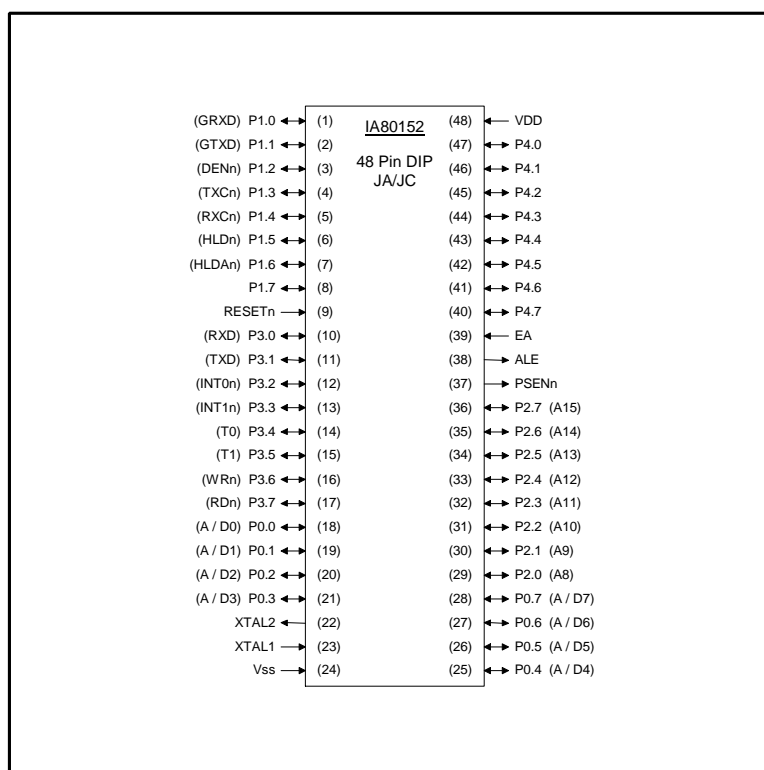

IA80C152**Preliminary Data Sheet****UNIVERSAL COMMUNICATIONS CONTROLLER****FEATURES**

- **Form, Fit, and Function Compatible with the Intel[®] 80C152**
- **Packaging options available**
 - 48 Pin Plastic or Ceramic DIP
 - 68 Pin Plastic or Ceramic LCC
- **8051 Core with:**
 - **Direct Memory Access(DMA)**
 - **Global Serial Channel (GSC)**
 - **MCS[®] - 51 Compatible UART**
 - **Two Timers/Counters**
 - **Maskable Interrupts**
- **Memory**
 - **256 Bytes Internal RAM**
 - **64K Bytes Program Memory**
 - **64K Bytes Data Memory**
- **5 or 7 I/O Ports**
- **Up to 16.5 MHz Clock Frequency**
- **Two-Channel DMA With Multiple Transfer Modes**
- **GSC Provides Support for Multiple Protocols**
 - **CSMA/CD**
 - **SDLC/HDLC**
 - **User Definable**
- **Separate Transmit & Receive FIFOs**
- **Special Protocol Features**
 - **Up to 2.0625 Mbps Serial Operation**
 - **CSMA and SDLC Frame Formats with CRC Checking**
 - **Manchester, NRZ, & NRZI Data Encoding**
 - **Collision Detection & Resolution in CSMA Mode**
 - **Selectable Full/Half Duplex**

**Figure 1 - 48 Pin DIP Pinout**

IA80C152

Preliminary Data Sheet

UNIVERSAL COMMUNICATIONS CONTROLLER

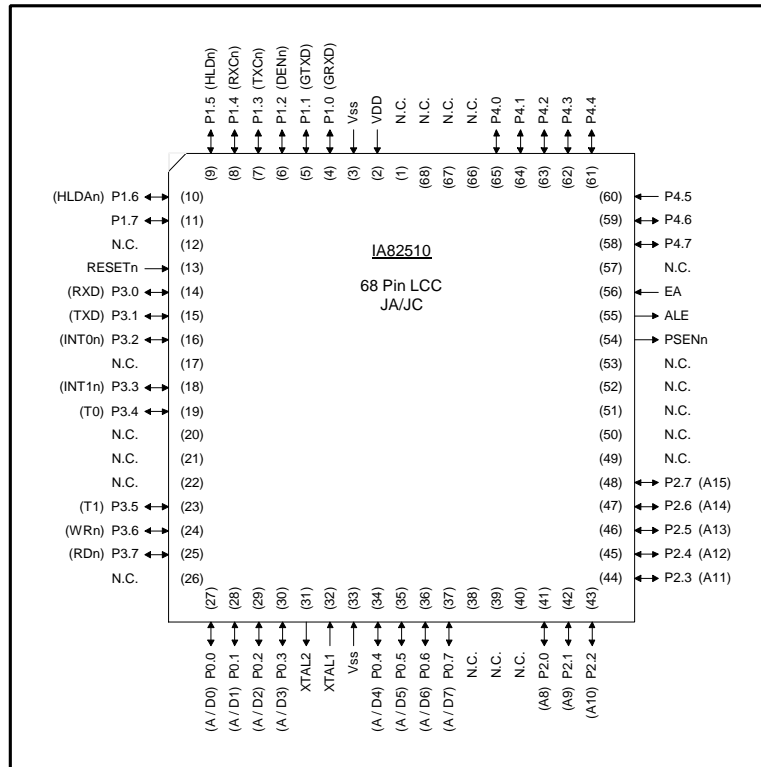

Figure 2 - 68 Lead LCC Pinout - JA/JC Versions

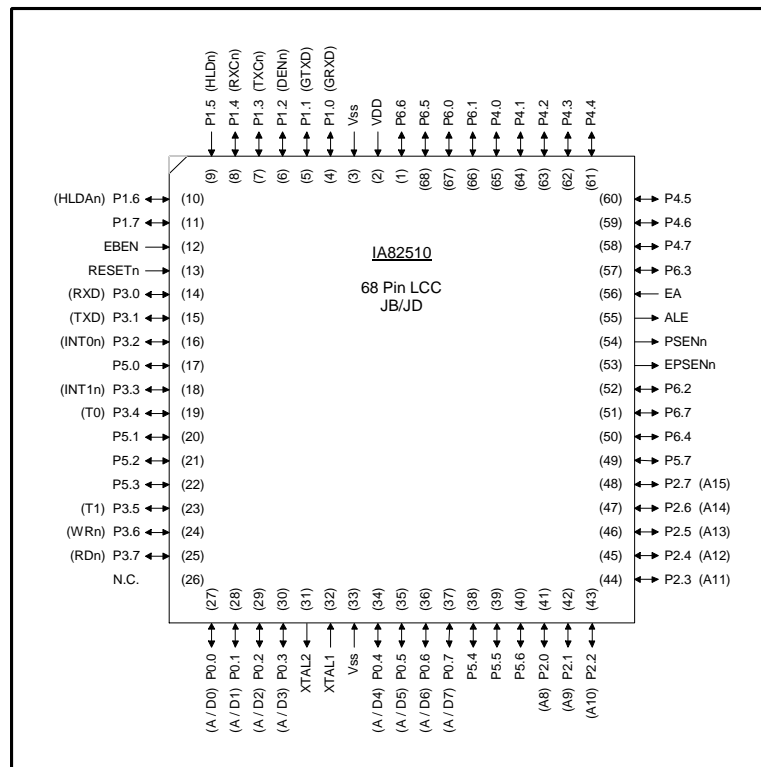

Figure 3 - 68 Lead LCC Pinout - JB/JD Versions

IA80C152**Preliminary Data Sheet****UNIVERSAL COMMUNICATIONS CONTROLLER**

The IA80C152 is a "plug-and-play" drop-in replacement for the original IC. **innovASIC** produces replacement ICs using its MILES™, or Managed IC Lifetime Extension System, cloning technology. This technology produces replacement ICs far more complex than "emulation" while ensuring they are compatible with the original IC. MILES™ captures the design of a clone so it can be produced even as silicon technology advances. MILES™ also verifies the clone against the original IC so that even the "undocumented features" are duplicated. This data sheet documents all necessary engineering information about the IA80C152 including functional and I/O descriptions, electrical characteristics, and applicable timing.

INTEL is a registered trademark of Intel Corporation

DESCRIPTION

The IA80C152 is a Universal Communications Controller (UCC) that is pin-for-pin compatible with the Intel™ 80C152. This version of the UCC is a ROMless version. The ROM version is identified as the 83C152 and can be easily derived from the 80C152 using a customer furnished ROM program. The IA80C152 can be programmed with the same software development tools and can transmit and receive using the same communication protocols as the Intel™ 80C152 making the IA80C152 a drop-in replacement. Table 1 below cross-references IA80C152 versions with protocol, package, and I/O Port capability. Pinout diagrams are provided in figures 1, 2, and 3.

Table 1 - IC Version Differences					
innovASIC Part Number	CSMA/CD, SDLC/HDLC, User-Defined	5 I/O Ports	7 I/O Ports	48 Pin DIP	68 Lead LCC
IA80C152JA	√	√		√	√
IA80C152JB	√		√		√
IA80C152JC	√	√		√	√
IA80C152JD	√		√		√

The only difference between The **innovASIC** 80C152 and the Intel™ 80C152 is that all protocols are available in all IC versions. Originally, the Intel™ 80C152 JC and JD versions were limited to SDLC/HDLC only. Also, **innovASIC** will support a ROM version (83152) in any of the JA, JB, JC, or JD versions.

The IA80C152 is partitioned into three major functional units identified as the C8051, the Direct Memory Access (DMA) Controller, and the Global Serial Channel (GSC). The C8051 is implemented using a CAST, Inc. Intellectual Property (IP) core. This core is instruction set compatible with the 80C51BH, and contains compatible peripherals including a UART interface and timers. The special function registers (SFRs) and interrupts are modified from the original 8051BH to accommodate the additional DMA controller and GSC peripherals.

The DMA Controller is a 2 channel, 8-bit device that is 16-bit addressable. Either channel can access any combination of reads and writes to external memory, internal memory, or the SFR's. Various modes allow the DMA to access the UART, GSC, SFRs, and internal and external memory as well as provide for external control. Since there is only 1 data/program memory bus, only one DMA channel or the microcontroller can have control at any give time. Arbitration within the device makes this control transparent to the programmer.

Copyright © 2000

innovASIC

[_____] *The End of Obsolescence™*

IA80C152**Preliminary Data Sheet****UNIVERSAL COMMUNICATIONS CONTROLLER**

The GSC is a serial interface that can be programmed to support CSMA/CD, SDLC, user definable protocols, and limited HDLC. Protocol specific features are supported in hardware such as address recognition, collision resolution, CRC generation and errors, automatic re-transmission, and hardware acknowledge. The CSMA/CD protocol meets the requirements of ISO/IEC 8802-3 and ANSI/IEEE Std 802.3 to the extent implemented in the original IC. The SDLC protocol meets the requirements of IBM GA27-3093-04 to the extent implemented in the original IC.

Functional Block Diagram

Figure 4 shows the major functional blocks of the IA80C152. Each version of the IA80C152 function identically to each other with the exception of the 2 additional I/O ports (Port 5 and Port 6) in the JB and JD versions.

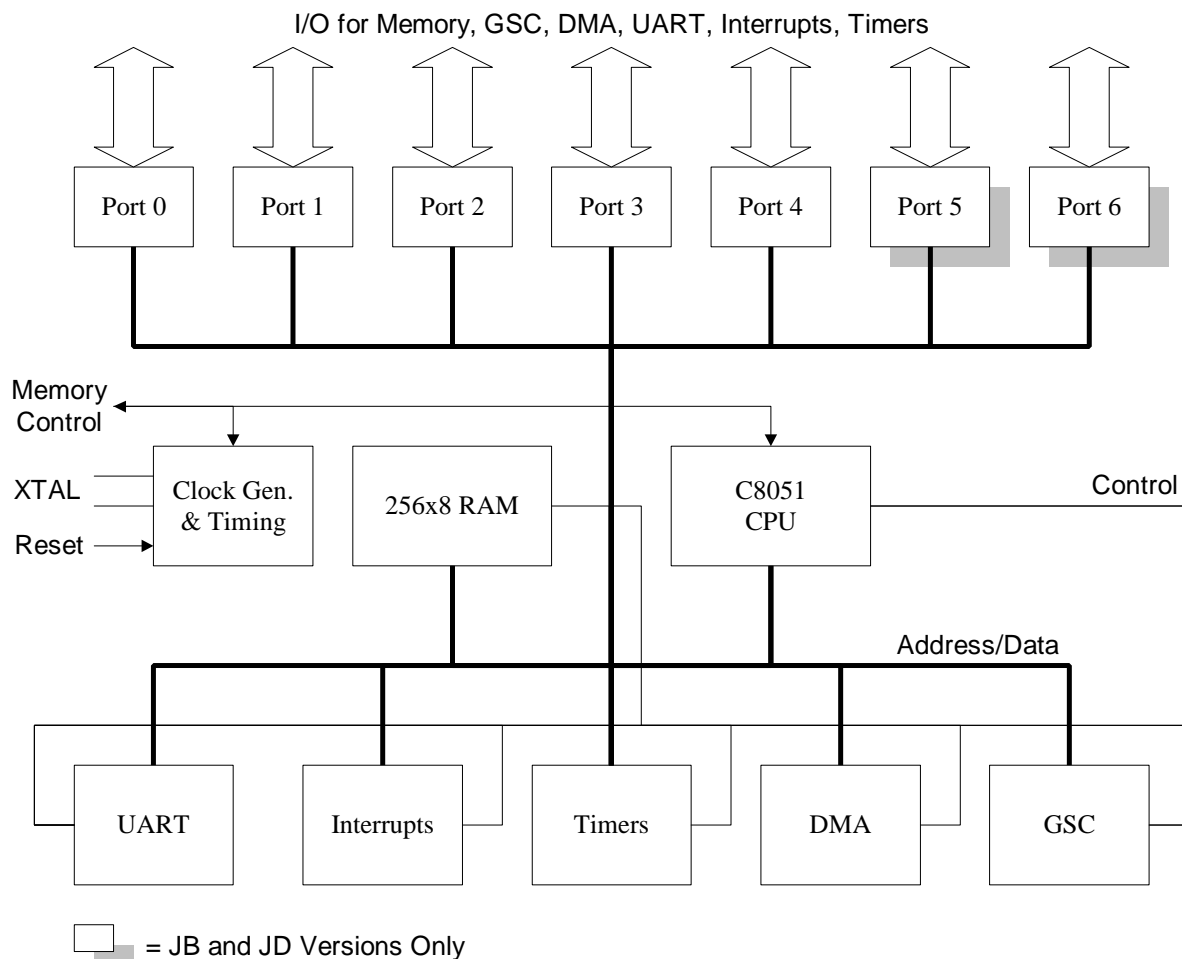
**Figure 4 - Functional Block Diagram**

IA80C152

Preliminary Data Sheet

UNIVERSAL COMMUNICATIONS CONTROLLER

I/O Signal Description

Table 2 below describes the I/O characteristics for each signal on the IC. The signal names correspond to the signal names on the pinout diagrams provided above. (!) Denotes active Low.

Table 2 - I/O Signal Descriptions	
Signal Name	Description
!EA	External Access enable. Since there is no internal ROM in the 80C152, this signal has no function in the JA and JC versions. For the JB and JD versions, controls program memory fetch locations.
!EPSEN	E-bus Program Store ENable. When EBEN is 1, this signal is the read strobe for external program memory.
!PSEN	Program Store ENable. When EBEN is 0, this signal is the read strobe for external program memory.
!RESET	Reset. When this signal is low for 3 machine cycles, the device is put into reset. The GSC may continue transmitting after reset is applied. An internal pull-up allow the use of an external capacitor to generate a power-on reset.
ALE	Address Latch Enable. Latches the low-byte of external memory.
EBEN	E-Bus ENable. In conjunction with EA, EBEN designates program memory fetches from either Port 0,2 or Port 5,6.
P0.0 P0.1 P0.2 P0.3 P0.4 P0.5 P0.6 P0.7	Port 0 - open drain 8-bit bi-directional port that bit addressable and can drive up to 8 LS TTL inputs. The port signals can be used as high impedance inputs. This port also provides the low-byte of the multiplexed address and data bus depending on the state of !EBEN.
P1.0 - GRXD, GSC Receive P1.1 - GTXD, GSC Transmit P1.2 - !DEN, Driver Enable P1.3 - !TXC, External Transmit Clock P1.4 - !RXC, External Receive Clock P1.5 - !HLD, DMA Hold P1.6 - !HLDA, DMA Hold Acknowledge P1.7	Port 1 - 8-bit bi-directional port that is bit addressable. To use a port signal as an input, write a 1 to the port location. Internal pull-ups pull the input high and source current when the input is driven low. To use a port signal as an output, a 1 or 0 written to the port location is presented at the output. Port signals in this port also serve as I/O for 80C152 functions. These I/O signals are defined next to the port name.
P2.0 P2.1 P2.2 P2.3 P2.4 P2.5 P2.6 P2.7	Port 2 - 8-bit bi-directional port that is bit addressable. To use a port signal as an input, write a 1 to the port location. Internal pull-ups pull the input high and source current when the input is driven low. To use a port signal as an output, a 1 or 0 written to the port location is presented at the output. This port also provides the high-byte of the multiplexed address and data bus depending on the state of !EBEN.
P3.0 - RXD, UART Receive P3.1 - TXD, UART Transmit P3.2 - !INT0, External Interrupt 0 P3.3 - !INT1, External Interrupt 1 P3.4 - T0, Timer 0 External Input P3.5 - T1, Timer 1 External Input P3.6 - !WR, External Data Memory Write Strobe P3.7 - !RD, External Data Memory Read Strobe	Port 3 - 8-bit bi-directional port that is bit addressable. To use a port signal as an input, write a 1 to the port location. Internal pull-ups pull the input high and source current when the input is driven low. To use a port signal as an output, a 1 or 0 written to the port location is presented at the output. Port signals in this port also serve as I/O for 80C152 functions. These I/O signals are defined next to the port name.
P4.0 P4.1 P4.2	Port 4 - 8-bit bi-directional port that is bit addressable. To use a port signal as an input, write a 1 to the port location. Internal pull-ups pull the input high and source current when the input is driven low. To

IA80C152**Preliminary Data Sheet****UNIVERSAL COMMUNICATIONS CONTROLLER****Table 2 - I/O Signal Descriptions**

Signal Name	Description
P4.3 P4.4 P4.5 P4.6 P4.7	use a port signal as an output, a 1 or 0 written to the port location is presented at the output.
P5.0 P5.1 P5.2 P5.3 P5.4 P5.5 P5.6 P5.7	Port 5 - 8-bit bi-directional port that is NOT bit addressable. To use the port as an input, write a 1 to the port location. Internal pull-ups pull the input high and source current when the input is driven low. To use the port as an output, 1s or 0s written to the port are presented at the output. This port also provides the low-byte of the multiplexed address and data bus depending on the state of !EBEN.
P6.0 P6.1 P6.2 P6.3 P6.4 P6.5 P6.6 P6.7	Port 6 - 8-bit bi-directional port that is NOT bit addressable. To use the port as an input, write a 1 to the port location. Internal pull-ups pull the input high and source current when the input is driven low. To use the port as an output, 1s or 0s written to the port are presented at the output. This port also provides the high-byte of the multiplexed address and data bus depending on the state of !EBEN.
VCC	Supply Voltage
VSS	Device Ground
XTAL1	Input to the internal clock generator
XTAL2	Output from the internal oscillator amplifier

Memory Space

Memory space is divided up into program and data memory. Program memory is all external to the IA80C152. Data memory is divided up into external and internal data memory. There can be up to 64K bytes of external program and data memory. Internal data memory is 256 bytes that is mapped between RAM, SFRs, and Register Banks. Figure 5 diagrams the organization of the IA80C152 memory space. See the C8051 section for further details.

Program memory is accessed using control signals and ports. On the JA and JC versions of the IA80C152 this access is performed through ports P0 and P2. Further, since there is no internal ROM, the entire program memory space is accessed via ports P0 and P2. On the JB and JD version of the IA80C152, program memory access can be through either ports P0 and P2, or ports P5 and P6. Which set of ports program memory fetches are made is controlled by the input signals !EA and !EBEN. Table 3 summarizes the IA80C152 versions and the relationship to program memory fetches.

IA80C152

Preliminary Data Sheet

UNIVERSAL COMMUNICATIONS CONTROLLER

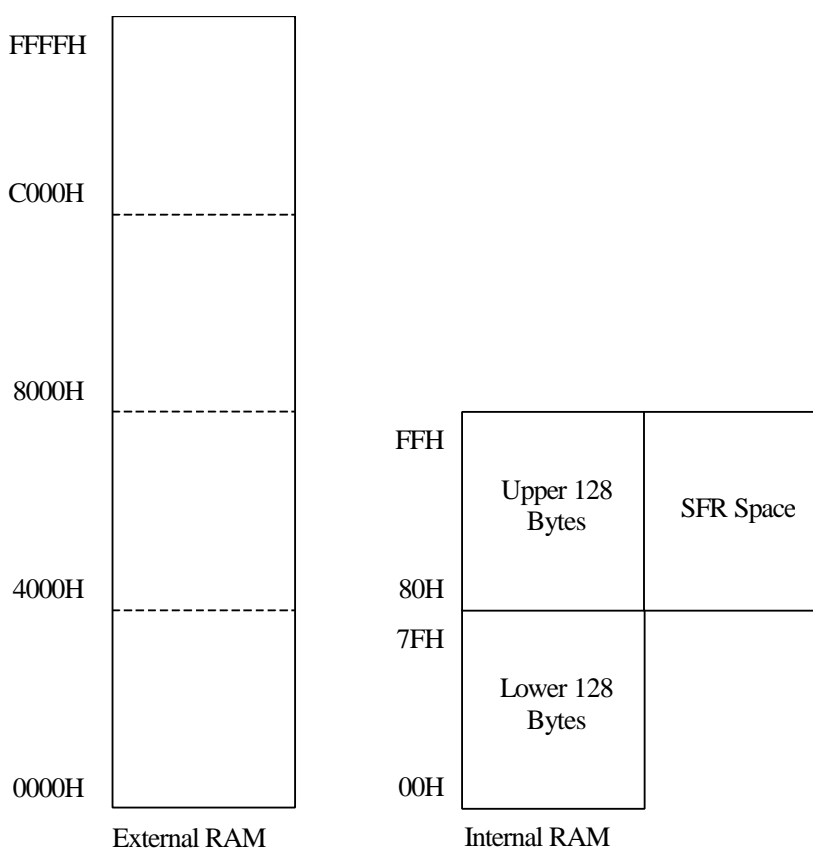

Figure 5 - Memory Space

Table 3 - Summary of Program Memory Fetches						
Version	Fetch Control		Fetch Ports	Fetch Signal		Memory Space
	EBEN	EA		PSEN	EPSEN	
JA, JC	N/A	0 or 1	P0, P2	Active	-	0h - FFFFh
JB, JD	0	0	P0, P2	Active	-	0h - FFFFh
	1	0	P5, P6	-	Active	0h - FFFFh
	1	1	P5, P6	-	Active	0h - 1FFFh
			P0, P2	Active	-	2000h - FFFFh

Summary of the 80C152 Registers and Interrupts

The 80C152 combines the register set of the 8051BH and additional SFRs for the DMA and GSC functions. Likewise, the 80C152 combines the interrupts of the 8051BH and the interrupts required by the DMA and GSC. Table 4 contains a summary of the 80C152 registers, and table 5 contains a summary of the 80C152 interrupts.

IA80C152 Preliminary Data Sheet

UNIVERSAL COMMUNICATIONS CONTROLLER

Table 4 - SFR Summary

Item	Register Name	Register Address	Functional Block	Description	Initial Value
1.	A	0E0h	C8051	Accumulator	00h
2.	ADR0	095h	GSC	Address Match 0	00h
3.	ADR1	0A5h	GSC	Address Match 1	00h
4.	ADR2	0B5h	GSC	Address Match 2	00h
5.	ADR3	0C5h	GSC	Address Match 3	00h
6.	AMSK0	0D5h	GSC	Address Mask 0	00h
7.	AMSK1	0E5h	GSC	Address Mask 1	00h
8.	B	0F0h	C8051	B Register	00h
9.	BAUD	094h	GSC	Baud Rate	00h
10.	BCRL0	0E2h	DMA	Byte Count Register (Low) 0	X
11.	BCRH0	0E3h	DMA	Byte Count Register (High) 0	X
12.	BCRL1	0F2h	DMA	Byte Count Register (Low) 1	X
13.	BCRH1	0F3h	DMA	Byte Count Register (High) 1	X
14.	BKOFF	0C4h	GSC	Backoff Timer	X
15.	DARL0	0C2h	DMA	Destination Address Register (Low) 0	X
16.	DARH0	0C3h	DMA	Destination Address Register (High) 0	X
17.	DARL1	0D2h	DMA	Destination Address Register (Low) 1	X
18.	DARH1	0D3h	DMA	Destination Address Register (High) 1	X
19.	DCON0	092h	DMA	DMA Control 0	00h
20.	DCON1	093h	DMA	DMA Control 1	00h
21.	DPH	083h	C8051	Data Pointer High	00h
22.	DPL	082h	C8051	Data Pointer Low	00h
23.	GMOD	084h	GSC	GSC Mode	X000000b
24.	IE	0A8h	C8051	Interrupt Enable	0XX0000b
25.	IEN1	0C8h	DMA, GSC	Interrupt Enable 1	XX00000b
26.	IFS	0A4h	GSC	Interframe Space	00h
27.	IP	0B8h	C8051	Interrupt Priority	XXX0000b
28.	IPN1	0F8h	DMA, GSC	Interrupt Priority 1	XX00000b
29.	MYSLOT	0F5h	GSC	GSC Slot Address	00h
30.	P0	080h	C8051	Port 0	0FFh
31.	P1	090h	C8051	Port 1	0FFh
32.	P2	0A0h	C8051	Port 2	0FFh
33.	P3	0B0h	C8051	Port 3	0FFh
34.	P4	0C0h	C8051	Port 4	0FFh
35.	P5	091h	C8051	Port 5	0FFh
36.	P6	0A1h	C8051	Port 6	0FFh
37.	PCON	087h	C8051	Power Control	0XXX000b
38.	PRBS	0E4h	GSC	Pseudo-Random Sequence	00h
39.	PSW	0D0h	C8051	Program Status Word	00h
40.	RFIFO	0F4h	GSC	Receive FIFO	X
41.	RSTAT	0E8h	GSC	Receive Status	00h
42.	SARL0	0A2h	DMA	Source Address Register (Low) 0	X
43.	SARH0	0A3h	DMA	Source Address Register (High) 0	X
44.	SARL1	0B2h	DMA	Source Address Register (Low) 1	X
45.	SARH1	0B3h	DMA	Source Address Register (High) 1	X
46.	SBUF	099h	C8051	Serial Channel Buffer (UART)	X
47.	SCON	098h	C8051	Serial Channel Control (UART)	00h
48.	SLOTTM	0B4h	GSC	GSC Slot Time	00h
49.	SP	081h	C8051	Stack Pointer	07h
50.	TCDCNT	0D4h	GSC	Transmit Collision Counter	X
51.	TCON	088h	C8051	Timer Control	00h

IA80C152

Preliminary Data Sheet

UNIVERSAL COMMUNICATIONS CONTROLLER

Table 4 - SFR Summary

Item	Register Name	Register Address	Functional Block	Description	Initial Value
52.	TFIFO	085h	GSC	Transmit FIFO	X
53.	TH0	08Ch	C8051	Timer (High) 0	00h
54.	TH1	08Dh	C8051	Timer (High) 1	00h
55.	TL0	08Ah	C8051	Timer (Low) 0	00h
56.	TL1	08Bh	C8051	Timer (Low) 1	00h
57.	TMOD	089h	C8051	Timer Mode	00h
58.	TSTAT	0D8h	GSC	Transmit Status	XX000100b

Table 5 - Interrupt Summary

Interrupt Priority	Interrupt Name	Priority Symbol Name	Enable Symbol Name	Priority Address	Enable Address	Vector Address
-	Enable All Interrupts	-	EA	-	0AFh	-
1	External Interrupt 0	PX0	EX0	0B8h	0A8h	03h
2	GSC Receive Valid	PGSRV	EGSRV	0F8h	0C8h	2Bh
3	Timer 0 Overflow	PT0	ET0	0B9h	0A9h	0Bh
4	GSC Receive Error	PGSRE	EGSRE	0F9h	0C9h	33h
5	DMA Channel 0 Done	PDMA0	EDMA0	0FAh	0CAh	3Bh
6	External Interrupt 1	PX1	EX1	0BAh	0AAh	13h
7	GSC Transmit Valid	PGSTV	EGSTV	0FBh	0CBh	43h
8	DMA Channel 1 Done	PDMA1	EDMA1	0FCh	0CCh	53h
9	Timer 1 Overflow	PT1	ET1	0BBh	0ABh	1Bh
10	GSC Transmit Error	PGSRE	EGSRE	0FDh	0CDh	4Bh
11	UART Transmit/Receive	PS	ES	0BCh	0ACh	23h

Power Conservation Modes

There are 2 power conservation modes identified as Idle Mode and Power Down Mode. The IA80C152 pins will have values according to the Table 6 below.

Idle Mode is entered through software control of the PCON register. Idle halts processor execution and the DMA. The GSC continue to operate to the extent that it can without the processor or DMA servicing its requests. Idle mode is exited upon receipt of any enabled interrupt or invoking a hardware reset.

Power Down Mode is entered through software control of the PCON register. Power Down disables the oscillator causing all functions to stop. RAM data is maintained since power is not removed from the device. The only way to exit power down mode is to invoke a hardware reset.

IA80C152**Preliminary Data Sheet****UNIVERSAL COMMUNICATIONS CONTROLLER****Table 6 - Power Conservation Modes**

Mode	Program Fetch	ALE	PSEN	EPSEN*	Port 0	Port 1	Port 2	Port 3	Port 4	Port 5*	Port 6*
Idle	P0, P2	1	1	1	Float	Data	Addr.	Data	Data	0FFh	0FFh
	P5, P6*	1	1	1	Data	Data	Data	Data	Data	0FFh	Addr.
Power Down	P0, P2	0	0	1	Float	Data	Data	Data	Data	0FFh	0FFh
	P5, P6*	0	1	0	Data	Data	Data	Data	Data	0FFh	0FFh

*JB and JD Versions Only

Oscillator Pins

There are 2 methods for providing a clock to the 80C152. One method is to provide a crystal oscillator and the other method is to provide an external clock source. When providing a crystal oscillator, the XTAL1 pin is the input and XTAL2 is the output. The min and max crystal frequencies are 3.5 MHz and 16.5 MHz, respectively.

When providing an external clock source, XTAL1 is the input and XTAL has no connection. Duty cycle does not matter to the device, however, the external clock source requires a minimum pulse width of 20 ns.

Summary of the 8051 Instruction Set

Table 7 provides a summary of the instruction set organized by hexadecimal opcode. Please refer to the original Intel™ Data Book for individual instruction set details.

IA80C152

Preliminary Data Sheet

UNIVERSAL COMMUNICATIONS CONTROLLER

Table 7 - Instruction Set Summary

Opcode	Mnemonic	Opcode	Mnemonic	Opcode	Mnemonic
00 H	NOP	30 H	JNB bit,rel	60 H	JZ rel
01 H	AJMP addr11	31 H	ACALL addr11	61 H	AJMP addr11
02 H	LJMP addr16	32 H	RETI	62 H	XRL direct,A
03 H	RR A	33 H	RLC A	63 H	XRL direct,#data
04 H	INC A	34 H	ADDC A,#data	64 H	XRL A,#data
05 H	INC direct	35 H	ADDC A,direct	65 H	XRL A,direct
06 H	INC @R0	36 H	ADDC A,@R0	66 H	XRL A,@R0
07 H	INC @R1	37 H	ADDC A,@R1	67 H	XRL A,@R1
08 H	INC R0	38 H	ADDC A,R0	68 H	XRL A,R0
09 H	INC R1	39 H	ADDC A,R1	69 H	XRL A,R1
0A H	INC R2	3A H	ADDC A,R2	6A H	XRL A,R2
0B H	INC R3	3B H	ADDC A,R3	6B H	XRL A,R3
0C H	INC R4	3C H	ADDC A,R4	6C H	XRL A,R4
0D H	INC R5	3D H	ADDC A,R5	6D H	XRL A,R5
0E H	INC R6	3E H	ADDC A,R6	6E H	XRL A,R6
0F H	INC R7	3F H	ADDC A,R7	6F H	XRL A,R7
10 H	JBC bit,rel	40 H	JC rel	70 H	JNZ rel
11 H	ACALL addr11	41 H	AJMP addr11	71 H	ACALL addr11
12 H	LCALL addr16	42 H	ORL direct,A	72 H	ORL C,direct
13 H	RRC A	43 H	ORL direct,#data	73 H	JMP @A+DPTR
14 H	DEC A	44 H	ORL A,#data	74 H	MOV A,#data
15 H	DEC direct	45 H	ORL A,direct	75 H	MOV direct,#data
16 H	DEC @R0	46 H	ORL A,@R0	76 H	MOV @R0,#data
17 H	DEC @R1	47 H	ORL A,@R1	77 H	MOV @R1,#data
18 H	DEC R0	48 H	ORL A,R0	78 H	MOV R0.#data
19 H	DEC R1	49 H	ORL A,R1	79 H	MOV R1.#data
1A H	DEC R2	4A H	ORL A,R2	7A H	MOV R2.#data
1B H	DEC R3	4B H	ORL A,R3	7B H	MOV R3.#data
1C H	DEC R4	4C H	ORL A,R4	7C H	MOV R4.#data
1D H	DEC R5	4D H	ORL A,R5	7D H	MOV R5.#data
1E H	DEC R6	4E H	ORL A,R6	7E H	MOV R6.#data
1F H	DEC R7	4F H	ORL A,R7	7F H	MOV R7.#data
20 H	JB bit,rel	50 H	JNC rel	80 H	SJMP rel
21 H	AJMP addr11	51 H	ACALL addr11	81 H	AJMP addr11
22 H	RET	52 H	ANL direct,A	82 H	ANL C,bit
23 H	RL A	53 H	ANL direct,#data	83 H	MOVC A,@A+PC
24 H	ADD A,#data	54 H	ANL A,#data	84 H	DIV AB
25 H	ADD A,direct	55 H	ANL A,direct	85 H	MOV direct,direct
26 H	ADD A,@R0	56 H	ANL A,@R0	86 H	MOV direct,@R0
27 H	ADD A,@R1	57 H	ANL A,@R1	87 H	MOV direct,@R1
28 H	ADD A,R0	58 H	ANL A,R0	88 H	MOV direct,R0
29 H	ADD A,R1	59 H	ANL A,R1	89 H	MOV direct,R1
2A H	ADD A,R2	5A H	ANL A,R2	8A H	MOV direct,R2
2B H	ADD A,R3	5B H	ANL A,R3	8B H	MOV direct,R3
2C H	ADD A,R4	5C H	ANL A,R4	8C H	MOV direct,R4
2D H	ADD A,R5	5D H	ANL A,R5	8D H	MOV direct,R5
2E H	ADD A,R6	5E H	ANL A,R6	8E H	MOV direct,R6
2F H	ADD A,R7	5F H	ANL A,R7	8F H	MOV direct,R7
90 H	MOV DPTR,#data16	C0 H	PUSH direct	F0 H	MOVX @DPTR,A
91 H	ACALL addr11	C1 H	AJMP addr11	F1 H	ACALL addr11
92 H	MOV bit,C	C2 H	CLR bit	F2 H	MOVX @R0,A

IA80C152

Preliminary Data Sheet

UNIVERSAL COMMUNICATIONS CONTROLLER

Table 7 - Instruction Set Summary

Opcode	Mnemonic	Opcode	Mnemonic	Opcode	Mnemonic
93 H	MOVC A,@A+DPTR	C3 H	CLR C	F3 H	MOVX @R1,A
94 H	SUBB A,#data	C4 H	SWAP A	F4 H	CPL A
95 H	SUBB A,direct	C5 H	XCH A,direct	F5 H	MOV direct,A
96 H	SUBB A,@R0	C6 H	XCH A,@R0	F6 H	MOV @R0,A
97 H	SUBB A,@R1	C7 H	XCH A,@R1	F7 H	MOV @R1,A
98 H	SUBB A,R0	C8 H	XCH A,R0	F8 H	MOV R0,A
99 H	SUBB A,R1	C9 H	XCH A,R1	F9 H	MOV R1,A
9A H	SUBB A,R2	CA H	XCH A,R2	FA H	MOV R2,A
9B H	SUBB A,R3	CB H	XCH A,R3	FB H	MOV R3,A
9C H	SUBB A,R4	CC H	XCH A,R4	FC H	MOV R4,A
9D H	SUBB A,R5	CD H	XCH A,R5	FD H	MOV R5,A
9E H	SUBB A,R6	CE H	XCH A,R6	FE H	MOV R6,A
9F H	SUBB A,R7	CF H	XCH A,R7	FF H	MOV R7,A
A0 H	ORL C,bit	D0 H	POP direct		
A1 H	AJMP addr11	D1 H	ACALL addr11		
A2 H	MOV C,bit	D2 H	SETB bit		
A3 H	INC DPTR	D3 H	SETB C		
A4 H	MUL AB	D4 H	DA A		
A5 H	-	D5 H	DJNZ direct,rel		
A6 H	MOV @R0,direct	D6 H	XCHD A,@R0		
A7 H	MOV @R1,direct	D7 H	XCHD A,@R1		
A8 H	MOV R0,direct	D8 H	DJNZ R0,rel		
A9 H	MOV R1,direct	D9 H	DJNZ R1,rel		
AA H	MOV R2,direct	DA H	DJNZ R2,rel		
AB H	MOV R3,direct	DB H	DJNZ R3,rel		
AC H	MOV R4,direct	DC H	DJNZ R4,rel		
AD H	MOV R5,direct	DD H	DJNZ R5,rel		
AE H	MOV R6,direct	DE H	DJNZ R6,rel		
AF H	MOV R7,direct	DF H	DJNZ R7,rel		
B0 H	ANL C,bit	E0 H	MOVX A,@DPTR		
B1 H	ACALL addr11	E1 H	AJMP addr11		
B2 H	CPL bit	E2 H	MOVX A,@R0		
B3 H	CPL C	E3 H	MOVX A,@R1		
B4 H	CJNE A,#data,rel	E4 H	CLR A		
B5 H	CJNE A,direct,rel	E5 H	MOV A,direct		
B6 H	CJNE @R0,#data,rel	E6 H	MOV A,@R0		
B7 H	CJNE @R1,#data,rel	E7 H	MOV A,@R1		
B8 H	CJNE R0,#data,rel	E8 H	MOV A,R0		
B9 H	CJNE R1,#data,rel	E9 H	MOV A,R1		
BA H	CJNE R2,#data,rel	EA H	MOV A,R2		
BB H	CJNE R3,#data,rel	EB H	MOV A,R3		
BC H	CJNE R4,#data,rel	EC H	MOV A,R4		
BD H	CJNE R5,#data,rel	ED H	MOV A,R5		
BE H	CJNE R6,#data,rel	EE H	MOV A,R6		
BF H	CJNE R7,#data,rel	EF H	MOV A,R7		

IA80C152**Preliminary Data Sheet****UNIVERSAL COMMUNICATIONS CONTROLLER****80C152 Register Set Descriptions**

The following are detailed descriptions for the IA80C152 register set. This register set is the same for all versions of the IA80C152. There is no difference between the IA80C152 register set and the register set for the original device.

In addition to the registers listed below, there are four banks of eight general purpose registers (R0 through R7) which reside within internal RAM space. Selection of these register banks is controlled through the Program Status Word (PSW).

The register descriptions are listed in alphanumeric order. The asterisk (*) indicates the register is bit addressable.

A* (0E0h) - Accumulator register used for various memory, arithmetic, and logic operations.

ADR0,1,2,3 (095h, 0A5h, 0B5h, 0c5h) - Address match registers contain the values which determine which data will be accepted as valid. If using 8 bit addressing mode a match with any of the four registers will cause the data to be accepted. If using 16 bit addressing mode a match with the pairs ADR1 and ADR2 or ADR3 and ADR2 will cause the data to be accepted. A received address of all 1s will be accepted regardless of whether the address mode is 16 bit or 8 bit.

B* (0F0h) - B register used for multiply and divide instructions. May also be used as a general purpose register.

AMSK0,1 (0D5h, 0E5h) - Address Match Mask registers are used to set the corresponding bit in Address match registers to don't care. Setting the bit to a one in the AMSK register sets the corresponding bit in the ADR register to don't care.

BAUD (094h) - Contains the value to be used by the baud rate determining equation. The value written to BAUD will actually be stored in a reload register. When the BAUD register contents are decremented to 00H the BAUD register will be reloaded from the reload register. Reading the BAUD register yields the current baud rate timer value. A read during a GSC operation may not give the current value since the value in BAUD could decrement after it is read and before the read value can be stored in its destination.

BCRL0, BCRH0 (0E2h, 0E3h) - Byte count register high and low bytes for DMA channel 0. The two registers provide a 16-bit value representing for the number of DMA transfers via channel 0. Valid count range is from 0 to 65535.

BCRL0, BCRH0 (0F2h, 0F3h) - Byte count register high and low bytes for DMA channel 1. The two registers provide a 16-bit value representing for the number of DMA transfers via channel 1. Valid count range is from 0 to 65535.

BKOFF (0C4h) - An 8 bit count down timer with a clock period equal to one slot time. A user may read the register, but the register is clocked asynchronously to the CPU so invalid data can result. Writing to BKOFF will have no effect.

DARL0, DARH0 (0C2h, 0C3h) - Destination address register high and low bytes for DMA channel 0. The two registers provide a 16-bit value representing the address of the destination for a DMA transfer via channel 0. Valid address range is from 0 to 65535.

DARL0, DARH0 (0D2h, 0D3h) - Destination address register high and low bytes for DMA channel 1. The two registers provide a 16-bit value representing the address of the destination for a DMA transfer via channel 1. Valid address range is from 0 to 65535.

DCON0,1 (092h, 093h) - DCON0 and DCON1 control DMA channel 0 or 1, respectively. Each bit in these 8-bit registers control the DMA transfer as described below.

7	6	5	4	3	2	1	0
<i>DAS</i>	<i>IDA</i>	<i>SAS</i>	<i>ISA</i>	<i>DM</i>	<i>TM</i>	<i>DONE</i>	<i>GO</i>

DAS - This bit in conjunction with *IDA* determine the destination address space.

IA80C152 Preliminary Data Sheet

UNIVERSAL COMMUNICATIONS CONTROLLER

IDA - If *IDA* is set to 1 then the destination address is automatically incremented after the transfer of each byte.

<i>DAS</i>	<i>IDA</i>	Destination	Auto-Increment
0	0	External Ram	NO
0	1	External Ram	YES
1	0	SFR	NO
1	1	Internal RAM	YES

SAS - This bit in conjunction with *ISA* determine the source address space.

ISA - If *ISA* is set to 1 then the source address is automatically incremented after the transfer of each byte.

<i>SAS</i>	<i>ISA</i>	Source	Auto-Increment
0	0	External Ram	NO
0	1	External Ram	YES
1	0	SFR	NO
1	1	Internal RAM	YES

DM - If this bit is set to a 1 then the DMA channel operates in demand mode. In this mode the DMA is initiated by either an external signal or by a serial port flag depending on the value of the *TM* bit. If the *DM* bit is set to a 0 then DMA is initiated by setting the *GO* bit.

TM - If *DM* is 1 then *TM* selects if DMA is initiated by an external signal (*TM*=1) or by a serial port bit (*TM*=0). If *DM* is 0 then *TM* selects whether DMA transfers are in burst mode (*TM*=1) or in alternate cycles mode (*TM*=0).

<i>DM</i>	<i>TM</i>	Mode
0	0	Alternate Cycles
0	1	Burst
1	0	Serial Port Demand
1	1	External Demand

DONE - This bit indicates that the DMA operation has completed. It also causes an interrupt. This bit is set to 1 when *BCRn* equals 0 and is set to 0 when the interrupt is vectored to. The user can also set and clear this bit.

GO - If this bit is set to 1 it enables the DMA channel.

DPL, DPH (082h, 083h) - *DPTR*, or the "data pointer" consists of the two 8-bit registers, *DPL* and *DPH*. The *DPTR* must be used for accesses to external memory requiring 16-bit addresses.

GMOD (084h) - An 8-bit register that controls the GSC Modes as described below.

7	6	5	4	3	2	1	0
<i>XTCLK</i>	<i>MI</i>	<i>MO</i>	<i>AL</i>	<i>CT</i>	<i>PL1</i>	<i>PL0</i>	<i>PR</i>

PR - If set to a 1 the GSC is in SDLC mode. If set to a 0 the GSC is in CSMA/CD mode.

PL0,1 - Preamble length:

<i>PL1</i>	<i>PL0</i>	Preamble length in bits
0	0	0
0	1	8
1	0	32
1	1	64

The length noted in the table includes the two bit BOF in CSMA/CD mode but not the SDLC flag. Zero length preamble is not compatible with CSMA/CD mode.

CT - This bit determines the CRC type used. If set to a 1 the 32 bit AUTODIN II-32 is used. If set to a 0 the 16 bit

IA80C152 Preliminary Data Sheet

UNIVERSAL COMMUNICATIONS CONTROLLER

CRC-CCITT is used.

AL - This bit determines the address length used. If set to a 1 the 16 bit addressing is used. If set to a 0 the 8 bit addressing is used.

M1, M0 - These bits contain the backoff mode select bits as defined in the following table.

<i>M1</i>	<i>M0</i>	Mode
0	0	Normal
0	1	Raw Transmit
1	0	Raw Receive
1	1	Alternate Backoff

In Raw Receive mode the transmitter operates normally. The receiver operates normally except that all the bytes following the BOF are loaded into the receive FIFO including the CRC.

In the Raw Transmit mode the receiver operates as normal and zero bit detection is performed. The transmit output is driven from the receiver input. Data transmitted is done so without a preamble, flag or zero bit insertion and without a CRC.

In the Alternate Backoff mode the backoff is modified so it is delayed until the end of the IFS. Since the IFS time is generally longer than the slot time this should help to prevent collisions.

XTCLK - This bit enables the use of an external transmit clock. A 1 enables the external clock (input on port 1, bit 3), a zero enables the internal baud rate generator.

IE* (0A8h) - The Interrupt Enable register allows the software to select which interrupts are enabled per the table below. If a bit is 0, the interrupt is disabled. If a bit is 1, the interrupt is enabled.

7	6	5	4	3	2	1	0
<i>EA</i>	-	-	<i>ES</i>	<i>ET1</i>	<i>EX1</i>	<i>ET0</i>	<i>EX0</i>

EA - Enable All interrupts. This bit globally enables or disables all interrupts regardless of the state of the individual bits.

ES - Enable or disable serial port interrupt.

ET1 - Enable or disable Timer 1 overflow interrupt.

EX1 - Enable or disable External Interrupt 1.

ET0 - Enable or disable Timer 0 overflow interrupt.

EX0 - Enable or disable External Interrupt 0.

IE* (0C8h) - The Interrupt Enable Number 1 register allows the software to select which interrupts are enabled per the table below. If a bit is 0, the interrupt is disabled. If a bit is 1, the interrupt is enabled.

7	6	5	4	3	2	1	0
-	-	<i>EGSTE</i>	<i>EDMA1</i>	<i>EGSTV</i>	<i>EDMA0</i>	<i>EGSRE</i>	<i>EGSRV</i>

EGSTE - Enable or disable GSC Transmit Error interrupt.

EDMA1 - Enable or disable DMA channel 1 interrupt.

EGSTV - Enable or disable GSC Transmit Valid interrupt.

EDMA0 - Enable or disable DMA channel 0 interrupt.

IA80C152**Preliminary Data Sheet****UNIVERSAL COMMUNICATIONS CONTROLLER**

EGSRE - Enable or disable GSC Receive Error interrupt.

EGSRV - Enable or disable GSC Receive Valid interrupt.

IFS (0A4h) - The Interframe Spacing register determines the number of bit times between transmitted frames in both CSMA/CD and SDLC. Only even bit times can be used. The number written to this register is divided by two and loaded into the seven most significant bits. An interframe space is created by counting down this seven bit number twice. The value read from this register is the current count value in the upper seven bits and the first or second count down in the LSB. A 1 indicates the first count down and a 0 indicates the second count down. The value may not be valid since the register is clocked asynchronously to the CPU.

IP* (0B8h) - The Interrupt Priority register allows the software to select which interrupts have a higher than normal priority. If a bit is 0, the interrupt has normal priority. If a bit is 1, the interrupt has a higher priority. When multiple bits are set to higher priority, interrupts are resolved in the same order as their normal priority setting.

7	6	5	4	3	2	1	0
-	-	-	<i>PS</i>	<i>PT1</i>	<i>PX1</i>	<i>PT0</i>	<i>PX0</i>

PS - Set normal or higher priority level for serial port interrupt.

PT1 - Set normal or higher priority level for Timer 1 overflow interrupt.

PX1 - Set normal or higher priority level for External Interrupt 1.

PT0 - Set normal or higher priority level for Timer 0 overflow interrupt.

PX0 - Set normal or higher priority level for External Interrupt 0.

IPN1* (0F8h) - The Interrupt Enable Number 1 register allows the software to select which interrupts have a higher than normal priority. If a bit is 0, the interrupt has normal priority. If a bit is 1, the interrupt has a higher priority. When multiple bits are set to higher priority, interrupts are resolved in the same order as their normal priority setting.

7	6	5	4	3	2	1	0
-	-	<i>PGSTE</i>	<i>PDMA1</i>	<i>PGSTV</i>	<i>PDMA0</i>	<i>PGSRE</i>	<i>PGSRV</i>

PGSTE - Set normal or higher priority level for GSC Transmit Error interrupt.

PDMA1 - Set normal or higher priority level for DMA channel 1 interrupt.

PGSTV - Set normal or higher priority level for GSC Transmit Valid interrupt.

PDMA0 - Set normal or higher priority level for DMA channel 0 interrupt.

PGSRE - Set normal or higher priority level for GSC Receive Error interrupt.

PGSRV - Set normal or higher priority level for GSC Receive Valid interrupt.

MYSLOT (0F5h) - Register that controls the slot address for the devices as well as the type of Jam used and which backoff algorithm is used during a collision.

7	6	5	4	3	2	1	0
<i>DCJ</i>	<i>DCR</i>	<i>SA5</i>	<i>SA4</i>	<i>SA3</i>	<i>SA2</i>	<i>SA1</i>	<i>SA0</i>

SA5-0 - The six slot address bits determine not only the address but also the priority. Addresses 0 through 63 are available with 63 having the highest priority and 1 the lowest. An address of 0 will prevent a station from transmitting during the collision resolution period.

DCR - The Deterministic Collision Resolution register determines which resolution algorithm to use. Setting this bit

IA80C152**Preliminary Data Sheet****UNIVERSAL COMMUNICATIONS CONTROLLER**

to a 1 selects the alternate collision resolution algorithm. Also disabled by setting this bit is the retriggering of the IFS on the reappearance of the carrier. Alternate Backoff mode must be used with this feature. The user must initialize TCDCNT with the maximum number of slots that are appropriate for the system. To disable the PBRs this register must be set to all 1s.

DCJ - A 1 selects DC type jam. A 0 selects AC type jam.

P0*, P1*, P2*, P3*, P4*, P5, P6 (080h, 090h, 0A0h, 0C0h, 091h, 0A1h) - These registers are for I/O as defined in the table below. Most registers have a dual function. P5 and P6 are not bit addressable and are only available in the JB and JD versions of the IC.

Port		Bit 7	Bit 6	Bit 5	Bit 4	Bit 3	Bit 2	Bit 1	Bit 0
P0	Function	Multiplexed Address/Data							
	Bit Address	087h	086h	085h	084h	083h	082h	081h	080h
P1	Function	-	HLDA	HLD	RXCn	TXCn	DENn	GTXD	GRXD
	Bit Address	097h	096h	095h	094h	093h	092h	091h	090h
P2	Function	Address and User Defined							
	Bit Address	0A7h	0A6h	0A5h	0A4h	0A3h	0A2h	0A1h	0A0h
P3	Function	RDn	WRn	T1	T0	INT1n	INT0n	TXD	RXD
	Bit Address	0B7h	0B6h	0B5h	0B4h	0B3h	0B2h	0B1h	0B0h
P4	Function	User Defined							
	Bit Address	0C7h	0C6h	0C5h	0C4h	0C3h	0C2h	0C1h	0C0h
P5	Function	User Defined							
	Bit Address	091h							
P6	Function	User Defined							
	Address	0A1h							

PCON (087h) - The POver CONTROL register controls the power down and idle states of the 80C152 as well as various UART, GSC, and DMA functions as defined below.

7	6	5	4	3	2	1	0
<i>SMOD</i>	<i>ARB</i>	<i>REQ</i>	<i>GAREN</i>	<i>XRCLK</i>	<i>GFIEN</i>	<i>PD</i>	<i>IDL</i>

SMOD - Doubles the baud rate of the UART if the bit is set to 1.

ARB - The DMA (both channels) is put into ARBiter mode if the bit is set to 1.

REQ - The DMA (both channels) is put into REQuester mode if the bit is set to 1.

GAREN - The GSC Auxiliary Receive Enable allows the GSC to receive back-to-back SDLC frames by setting the bit to 1. This bit has no effect in CSMA mode.

XRCLK - Setting this bit enables the External Receive Clock to be used by the receiver portion of the GSC.

GFIEN - The GSC Flag Idle Enable bit generates idle flags between transmitted SDLC frames when this bit is set to a 1. This bit has no effect in CSMA mode.

PD - The Power Down bit puts the 80C152 into the power down power saving mode by setting this bit to a 1.

IDL - The IDLe bit puts the 80C152 into the idle power saving mode by setting this bit to a 1.

PRBS (0E4h) - This register contains the pseudo-random number to be used in the CSMA/CD backoff algorithm. The number is generated by using a feedback shift register clocked by the CPU phase clocks. Writing all 1s to this register will cause the register to freeze at all 1s. Writing any other value to it will cause it to start again. A read of this register will not always give the seed value due to the register being clocked by the CPUs phase clocks.

IA80C152 Preliminary Data Sheet

UNIVERSAL COMMUNICATIONS CONTROLLER

PSW* (0D0h) - The Program Status Word register provides arithmetic and other microcontroller status as well as control for the selection of register banks 0 through 4.

7	6	5	4	3	2	1	0
<i>CY</i>	<i>AC</i>	<i>F0</i>	<i>RS1</i>	<i>RS0</i>	<i>OV</i>	-	<i>P</i>

CY - Carry Flag set to 1 if an instruction execution results in a carry.

AC - Auxiliary Carry Flag set to 1 if an instruction execution results in a carry.

F0 - Flag 0 available for user defined general purpose.

RS1, RS0 - Register bank Select 1 bit and Register bank Select 0 bit in combination define the current register bank to be used by the microprocessor. See table below.

Register Bank	<i>RS1</i>	<i>RS0</i>	Register Bank Addresses
0	0	0	00h-07h
1	0	1	08h-0Fh
2	1	0	10h-17h
3	1	1	18h-1fh

OV - The Overflow bit indicates an arithmetic overflow when set to a 1.

P - Parity flag set or cleared by the hardware each instruction to indicate odd or even number of 1's in the accumulator.

RFIFO (0F4h) - This is a 3 byte buffer which points to the oldest data in the buffer. The buffer is loaded with receive data every time the receiver receives a new byte of data.

RSTAT* (0E8h) - This register provides status of the GSC receiver as defined below.

7	6	5	4	3	2	1	0
<i>OR</i>	<i>RCABT</i>	<i>AE</i>	<i>CRCE</i>	<i>RDN</i>	<i>RFNE</i>	<i>GREN</i>	<i>HABEN</i>

HABEN - The Hardware Based Acknowledge Enable when set to a 1 enables this feature.

GREN - When this bit is set the receiver is enabled to accept incoming frames. RFIFO should be cleared before setting this bit by reading RFIFO until RFNE = 0. This should be done since setting GREN to a 1 clears RFIFO. It takes twelve clock cycles for the status of RFNE to be updated after a read of RFIFO. Setting GREN also clears RDN, CRCE, AE and RCABT. GREN is cleared by hardware at the end of a reception or if receive errors are encountered. The user is responsible for setting this bit to a 1. The user or the GSC can set this bit to a 0. In CSMA/CD mode the status of GREN has no effect on whether the receiver detects a collision since the receiver always monitors the receive pin.

RFNE - This bit if set indicates that the receive FIFO is not empty. This flag is controlled by the GSC. If all the data is read from the FIFO the GSC will clear the bit.

RDN - This bit is controlled by the GSC and if set indicates a successful receive operation has occurred. This bit will not be set if a CRC, alignment, abort, or FIFO overrun error occurred.

CRCE - This bit is controlled by the GSC and if set indicates that a properly aligned frame was received without a mismatched CRC.

AE - This bit is set by the GSC in CSMA/CD mode to indicate that the receiver shift register is not full and the CRC is bad when the EOF was detected. If the CRC is correct AE will not be set and a misalignment will be assumed to be caused by 'dribble bits' as the line went idle. In SDLC mode AE is set if a non-byte aligned flag is received. CRCE may also be set.

RCABT - This bit is set by the GSC when a collision is detected after data has been loaded into the receive FIFO in

IA80C152 Preliminary Data Sheet

UNIVERSAL COMMUNICATIONS CONTROLLER

CSMA/CD mode. In SDLC mode this bit indicates that 7 consecutive 1s were detected before an end flag but after data was loaded into the receive FIFO. AE may also be set.

OR - This bit is set by the GSC to indicate that the receive FIFO was full and then new data was shifted into it. AE and /or CRCE may also be set. This flag is cleared by the user.

SARL0, SARH0 (0A2h, 0A3h) - Source address register high and low bytes for DMA channel 0. The two registers provide a 16-bit value representing the address of the source for a DMA transfer via channel 0. Valid address range is from 0 to 65535.

SARL1, SARH1 (0B2h, 0B3h) - Source address register high and low bytes for DMA channel 1. The two registers provide a 16-bit value representing the address of the source for a DMA transfer via channel 1. Valid address range is from 0 to 65535.

SBUF (099h) - Writes to this register load the transmit register, and reads access the receive register.

SCON* (098h) - This register controls the set up of the UART as defined by the table below.

7	6	5	4	3	2	1	0
SM0	SM1	SM2	REN	TB8	RB8	TI	RI

SM0, SM - The combination of these 2 bits controls the mode and type of baud rate.

Mode	SM0	SM1	Description	Baud Rate
0	0	0	Shift Register	(Osc. Freq.)/12
1	0	1	8-bit UART	Variable
2	1	0	9-bit UART	(Osc. Freq.)/64 or (Osc. Freq.)/32
3	1	1	9-bit UART	Variable

SM2 - When this bit is set and the UART mode is 1, RI will not be activated unless a valid stop bit is received. When this bit is set and the UART mode is 2 or 3, RI will not be activated if the 9th bit is 0.

REN - Setting this bit enables the UART to receive. Clearing this bit disables UART reception.

TB8 - In modes 2 and 3, the value of this bit is transmitted during the 9th bit time. This bit is set or cleared by software.

RB8 - In modes 2 and 3, this bit is the value of the 9th bit that was received by the UART. In mode 1, this bit is the value of the stop bit received by the UART.

TI - Transmit Interrupt flag set by hardware upon at the end of the 8th bit in mode 0 or at the beginning of the stop bit in modes 1, 2, or 3. This bit must be cleared by software to clear the interrupt.

RI - Receive Interrupt flag set by hardware at the end of the 8th bit in mode 0 or halfway through the stop bit in modes 1, 2, or 3. This bit must be cleared by software to clear the interrupt.

SLOTTM (0B4h) - Determines the length of the slot time in CSMA/CD mode. A slot time equals SLOTTM * (1 / baud rate). Reads from this location are unreliable since this register is clocked asynchronously to the CPU. Loading a value of 0 results in a slot time of 256 bit times.

SP (081h) - This register is the stack pointer. Its value points to the memory location that is the beginning of the stack.

TCDCNT (0D4h) - If probabilistic CSMA/CD is used this register contains the number of collisions. The user must clear this register before transmitting a new frame so the GSC can distinguish between a new frame and the retransmit of a frame. In deterministic backoff mode TCDCNT is used to hold the maximum number of slots.

TCON* (088h) - This register controls the operation of the Timers 0 and 1 and External Interrupts 0 and 1 as defined by the table below.

IA80C152 Preliminary Data Sheet

UNIVERSAL COMMUNICATIONS CONTROLLER

7	6	5	4	3	2	1	0
<i>TF1</i>	<i>TR1</i>	<i>TF0</i>	<i>TR0</i>	<i>IE1</i>	<i>IT1</i>	<i>IE0</i>	<i>IT0</i>

TF1 - Timer overFlow 1 interrupt flag set by hardware when timer 1 overflows. Hardware clears this flag when the processor vectors to the interrupt service routine.

TR1 - Timer Run 1 flag set by software to turn on timer 1 and cleared by software to turn off timer 1.

TF0 - Timer overFlow 0 interrupt flag set by hardware when timer 0 overflows. Hardware clears this flag when the processor vectors to the interrupt service routine.

TR0 - Timer Run 0 flag set by software to turn on timer 0 and cleared by software to turn off timer 0.

IE1 - Interrupt External 1 flag set by hardware when an edge is detected on External Interrupt 1. Hardware clears this flag when the processor vectors to the interrupt service routine.

IT1 - Interrupt Trigger 1 flag is set by software to specify a falling edge triggered interrupt for External Interrupt 1. The flag is cleared by software to specify a low level triggered interrupt for External Interrupt 1.

IE0 - Interrupt External 0 flag set by hardware when an edge is detected on External Interrupt 0. Hardware clears this flag when the processor vectors to the interrupt service routine.

IT0 - Interrupt Trigger 0 flag is set by software to specify a falling edge triggered interrupt for External Interrupt 0. The flag is cleared by software to specify a low level triggered interrupt for External Interrupt 0.

TFIFO (085h) - This is the 3 byte buffer used for storing transmit data. If T_{EN} is set to a 1 transmission begins as soon as data is written to TFIFO.

TH0, TL0 (08Ch, 08Ah) - These registers provide the high byte (TH0) and low byte (TL0) values for Timer 0. These registers may be used together or separately depending on Timer 0 mode bits.

TH1, TL1 (08Dh, 08Bh) - These registers provide the high byte (TH0) and low byte (TL0) values for Timer 0. These registers may be used together or separately depending on Timer 0 mode bits.

TMOD (089h) - This register controls the set up and modes of Timers 0 and 1 as defined by the table below.

7	6	5	4	3	2	1	0
Timer 1				Timer 0			
<i>GATE</i>	<i>C/Tn</i>	<i>M1</i>	<i>M0</i>	<i>GATE</i>	<i>C/Tn</i>	<i>M1</i>	<i>M0</i>

GATE - When this bit is set, Timers/Counters may be turned on or off by the corresponding External Interrupt, if the appropriate TR bit is set. When this bit is cleared, Timers/Counters may only be turned on or off by the appropriate TR bit.

C/Tn - Counter/Timer flag. Set by software for Counter operation, cleared by software for Timer operation.

M1, M0 - Set the mode of the Timers/Counters as defined by the table below.

Mode	<i>M1</i>	<i>M0</i>	Description
0	0	0	13-bit Timer
1	0	1	16-bit Timer/Counter
2	1	0	8-bit Auto Reload Timer/Counter
3	1	1	One 8-bit Timer/Counter (TL0) controlled by Timer 0 control bits. One 8-bit Timer/Counter (TH0) controlled by Timer 1 control bits.

TSTAT* (0D8h) - This register provides status of the GSC transmitter as defined below.

IA80C152**Preliminary Data Sheet****UNIVERSAL COMMUNICATIONS CONTROLLER**

7	6	5	4	3	2	1	0
<i>LNI</i>	<i>NOACK</i>	<i>UR</i>	<i>TCDT</i>	<i>TDN</i>	<i>TFNF</i>	<i>TEN</i>	<i>DMA</i>

DMA - If this bit is set it indicates that the DMA channels are used to service the RFIFO and TFIFO and that GSC interrupts occur on TDN and RDN. If set it also enables UR to become set. If this bit is cleared it indicates that the GSC is operating in normal mode and interrupts occur on TFNF and RFNE.

TEN - When TEN is set it will cause TDN, UR, TCDT and NOACK to be reset and the TFIFO to be cleared. The transmitter will clear TEN after a successful transmission, a collision during data, CRC or end flag. The user sets the bit and the user of the GSC can clear the bit. If the bit is cleared during a transmission the transmit pin goes to a high level. This is the method used to send an abort character in SDLC. DEN is also forced to a high level. An end of transmission occurs whenever the TFIFO is emptied.

TFNF - If this bit is a 1 TFIFO is not full and new data may be written to it.

TDN - The GSC sets this bit to indicate that a frame transmission completed successfully. If HABEN is set, TDN will not be set until the end of the IFS so that the acknowledge can be checked. TDN will not be set if an acknowledge is expected but not received. An acknowledge will not be expected after a broadcast or a multi-cast packet.

TCDT - The GSC sets this bit to indicate that the transmission stopped due to a collision. The bit is set by a collision occurring during the data, the CRC or if there are more than 8 collisions.

UR - The GSC sets this bit to indicate that in DMA mode the last bit was shifted out of the transmit register and that the DMA byte count did not equal 0. When this occurs the transmitter stops without sending the CRC and the end flag.

NOACK - The GSC sets this bit to indicate that an acknowledge was not received for the previous frame. This bit will be set only if HABEN is set and no acknowledge is received before the end of the IFS. NOACK will not be set following a broadcast or a multi-cast packet.

LNI - The GSC sets this bit to indicate that the receive line is idle. In CSMA/CD mode LNI is set if GRXD remains high for ~ 1.6 bit times. LNI is cleared after a transition on GRXD. In SDLC node LNI is set if 15 consecutive ones are received.

IA80C152

Preliminary Data Sheet

UNIVERSAL COMMUNICATIONS CONTROLLER

Absolute Maximum Ratings

AC/DC Parameters

Ambient temperature under bias.....	-40°C to +85°C ⁽²⁾
Operating temperature... ..	-40°C to +85°C
Storage temperature.....	-65°C to +150°C
Voltage on any pin to VSS.....	-0.3 to (V _{DD} +0.3)
Power dissipation.....	391.1 mW (95°C, 16MHz, 15% Toggle)

Stresses beyond those listed under “absolute maximum ratings” may cause permanent damage to the device. Operating the device beyond the conditions indicated in the “recommended operating conditions” section is not recommended. Operation at the “absolute maximum ratings” may adversely affect device reliability.

Notes: Design, Static and Dynamic Timing Characterization in Progress.

Table 8: DC Characteristics

Symbol	Parameter	Min	Typ	Max	Unit	Test Conditions
V _{IL}	Input Low Voltage (All Except EAn, EBEN)				V	
V _{IL1}	Input Low Voltage (EAn, EBEN)				V	
V _{IH}	Input High Voltage (Except XTAL1, RSTn)				V	
V _{IH1}	Input High Voltage (XTAL1 RSTn)				V	
V _{OL}	Output Low Voltage (Ports 1, 2, 3, 4, 5, 6)				V	
V _{OL1}	Output Low Voltage (Ports 0, ALE,PSEnN, EPSEnN)				V	
V _{OH}	Output High Voltage (Ports 1, 2, 3, 4, 5, 6, COMM9 ALE, PSEnN, EPSEnN)				V	
					V	
V _{OH1}	Output High Voltage (Port 0 in External Bus Mode)				V	
					V	
I _{IL}	Logical 0 Input Current (Ports 1, 2, 3, 4, 5, 6)				μA	
I _{TL}	Logical 1 to 0 Transition Current (Ports 1, 2, 3, 4, 5, 6)				μA	
I _{LI}	Input Leakage (Port 0, EAn)				μA	
RRST	Reset Pull-up Resistor				kΩ	
I _{IH}	Logical 1 Input Current (EBEN)				μA	
I _{DD}	Power Supply Current: Active (16.5 MHz) Idle(16.5 MHz) Power Down Mode				mA	
					mA	
			100		μA	(1)

Notes:

(1) Static I_{DD} current is exclusive of input/output drive requirements and is measured with the clocks stopped and all inputs tied to V_{DD} or V_{SS}, configured to draw minimum current.

(2) The input and output parametric values in section VII-B, parts 1, 2, and 3, are directly related to ambient temperature and DC supply voltage. A temperature or supply voltage range other than those specified in the Operating Conditions above will affect these values and part performance is not guaranteed by **innovASIC**.

IA80C152

Preliminary Data Sheet

UNIVERSAL COMMUNICATIONS CONTROLLER

A. C. Characteristics

Table 9: External Program and Data Memory Characteristics

Symbol	Parameter	16.5 MHz		Variable Oscillator		Unit
		Min	Max	Min	Max	
1/TCLCL	Oscillator Frequency 80C152JA/JC 83C152JA/JC 83C152JB/JD			3.5	12	MHZ
	80C152JA/JC-1 83C152JA/JC-1 80C152JB/JD-1			3.5	16.5	MHZ
TLHLL	ALE Pulse Width					ns
TAVLL	Address Valid to ALE Low					ns
TLLAX	Address Hold After ALE Low					ns
TLLIV	ALE Low to Valid Instruction In					ns
TLLPL	ALE Low to PSEnN Low					ns
TPLPH	PSEnN Pulse Width					ns
TPLIV	PSEnN Low to Valid Instruction In					ns
TPXIX	Input Instruction Hold After PSEnN	0		0		ns
TPXIZ	Input Instruction Float After PSEnN					ns
TAVIV	Address to Valid Instruction In					ns
TPLAZ	PSEnN Low to Address Float					ns
TRLRH	RDn Pulse Width					ns
TWLWH	WRn Pulse Width					ns
TRLDV	RDn Low to Valid Data In					ns
TRHDX	Data Hold After RDn	0		0		ns
TRHDZ	Data Float After RDn					ns
TLLDV	ALE Low to Valid Data In					ns
TAVDV	Address to Valid Data In					ns
TLLWL	ALE Low to RDn or WRn Low					ns
TAVWL	Address to RDn or WRn Low					ns
TQVWX	Data Valid to WRn Transition					ns
TWHQX	Data Hold After WRn					ns
TRLAZ	RDn Low to Address Float		0		0	ns
TWHLH	RDn or WRn High to ALE High					ns

Input leakage is $\pm 1\mu\text{A}$

IA80C152 Preliminary Data Sheet

UNIVERSAL COMMUNICATIONS CONTROLLER

Figure 6: External Program Memory Read Cycle

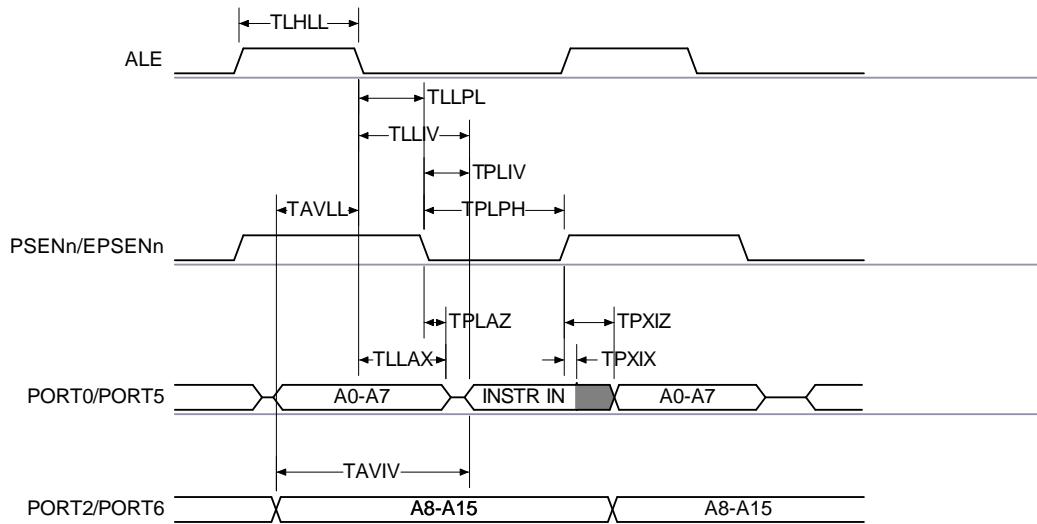
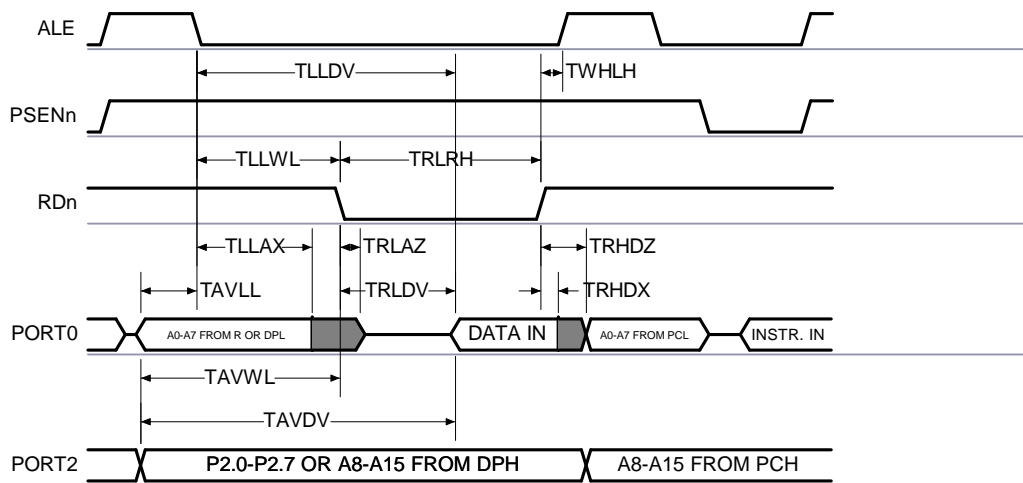

Figure 7: External Data Memory Read Cycle



IA80C152 Preliminary Data Sheet

UNIVERSAL COMMUNICATIONS CONTROLLER

Figure 8: External Data Memory Write Cycle

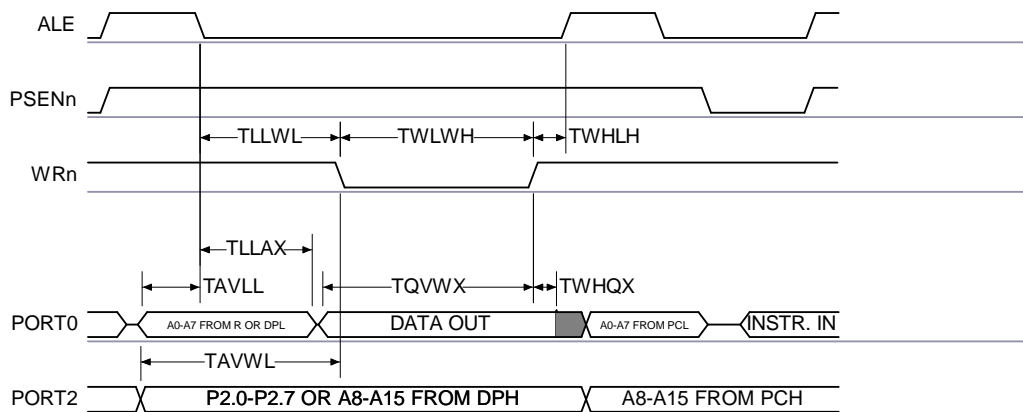
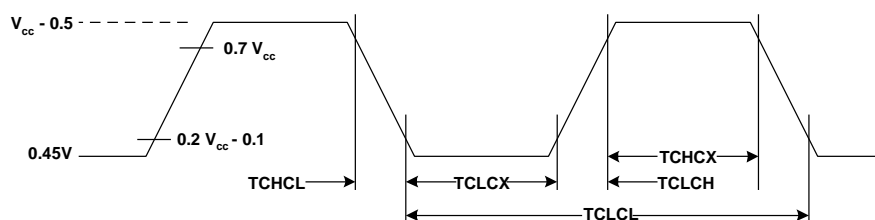

Table 10: External Clock Drive

Symbol	Parameter	Min	Max	Units
1/TCLCL	Oscillator Frequency	3.5	16.5	MHz
TCHCX	High Time	20		ns
TCLCX	Low Time	20		ns
TCLCH	Rise Time		20	ns
TCHCL	Fall Time		20	ns

Figure 9: External Clock Drive Waveform



UNIVERSAL COMMUNICATIONS CONTROLLER

Table 11: Local Serial Channel Timing - Shift Register Mode

Symbol	Parameter	16.5 MHz		Variable Oscillator		Units
		Min	Max	Min	Max	
TXLXL	Serial Port Clock Cycle Time			12TCLCL		ns
TQVXH	Output Data Setup to Clock Rising Edge					ns
TXHQX	Output Data Hold After Clock Rising Edge					ns
TXHDX	Input Data Hold After Clock Rising Edge					ns
TXHDV	Clock Rising Edge to Input Data Valid					ns

Figure 10: Shift Register Mode Timing Waveforms

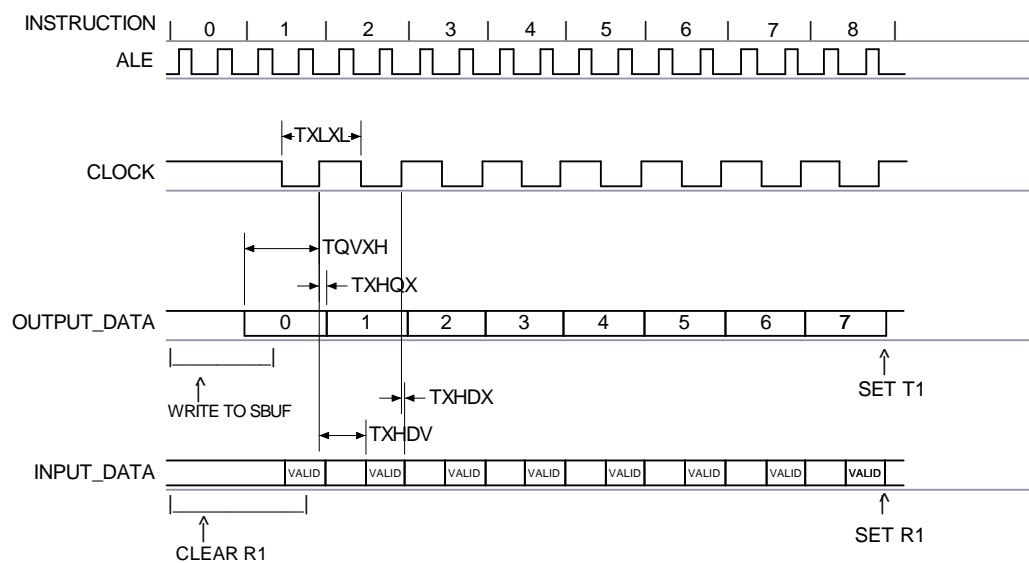

UNIVERSAL COMMUNICATIONS CONTROLLER

Table 12: Global Serial Port Timings - Internal Baud Rate Generator

Symbol	Parameter	16.5 MHz (BAUD = 0)		Variable Oscillator		Unit
		Min	Max	Min	Max	
HBTJR	Allowable jitter on the Receiver for 1/2 bit time (Manchester encoding only)		0.0375			μ s
FBTJR	Allowable jitter on the Receiver for one full bit time (NRZI and Manchester)		0.10			μ s
HBTJT	Jitter of data from Transmitter for 1/2 bit time (Manchester encoding only)		± 10		± 10	ns
FBTJT	Jitter of data from Transmitter for one full bit time (NRZI and Manchester)		± 10		± 10	ns
DRTR	Data rise time for Receiver		20.00		20.00	ns
DFTR	Data fall time for Receiver		20.00		20.00	ns

Figure 11: GSC Receiver Timings (Internal Baud Rate Generator)

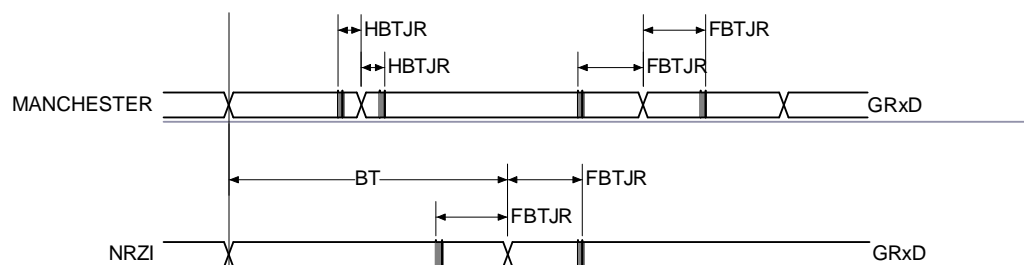
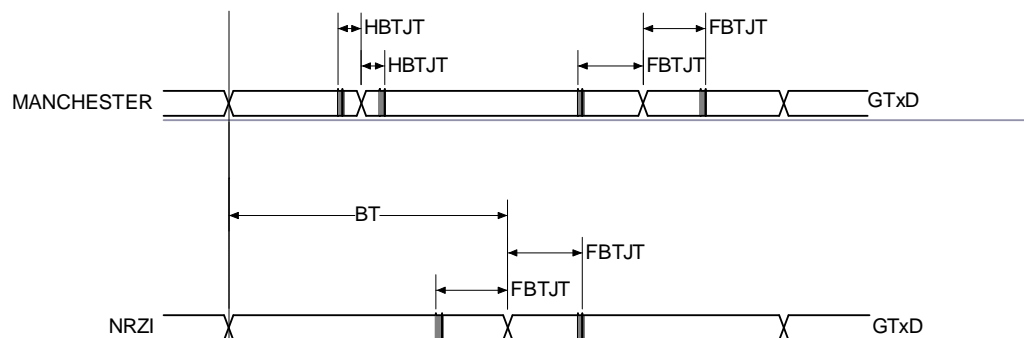

Figure 12: GSC Transmit Timings (Internal Baud Rate Generator)



UNIVERSAL COMMUNICATIONS CONTROLLER

Table 13: Global Serial Port Timings - External Clock

Symbol	Parameter	16.5 MHz		Variable Oscillator		Unit
		Min	Max	Min	Max	
1/ECBT	GSC Frequency with an External Clock		2.4	0.009		MHz
ECH	External Clock High					ns
ECL	External Clock Low					ns
ECRT	External Clock Rise Time					ns
ECFT	External Clock Fall Time					ns
ECDVT	External Clock to Data Valid Out - Transmit (To External Clock Negative Edge)					ns
ECDHT	External Clock to Data Hold - Transmit (To External Clock Negative Edge)					ns
ECDSR	External Clock to Data Set-up - Receiver (To External Clock Positive Edge)					ns
ECDHR	External Clock to Data Hold - Receiver (To External Clock Positive Edge)					ns

Figure 13: GSC Timings (External Clock)

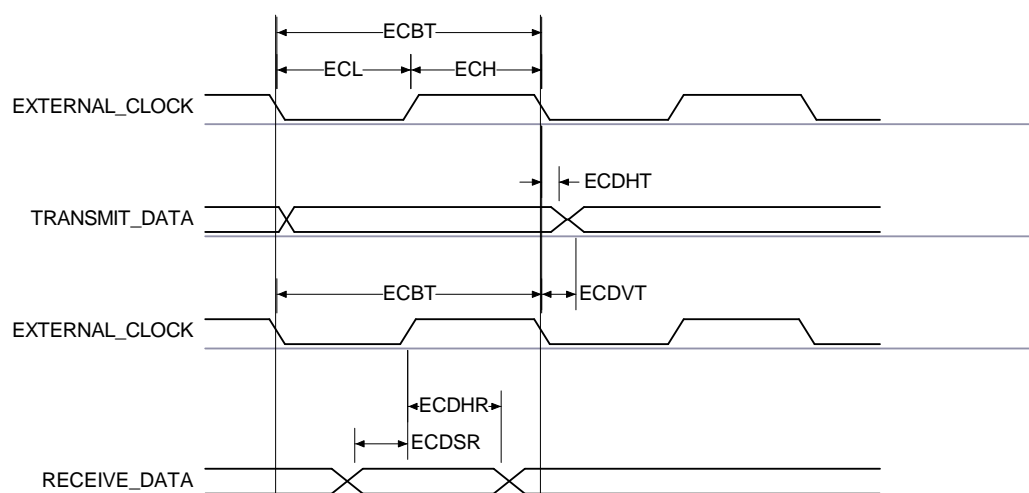

IA80C152

Preliminary Data Sheet

UNIVERSAL COMMUNICATIONS CONTROLLER

PLCC Packaging Dimensions (Theta J = TBD)

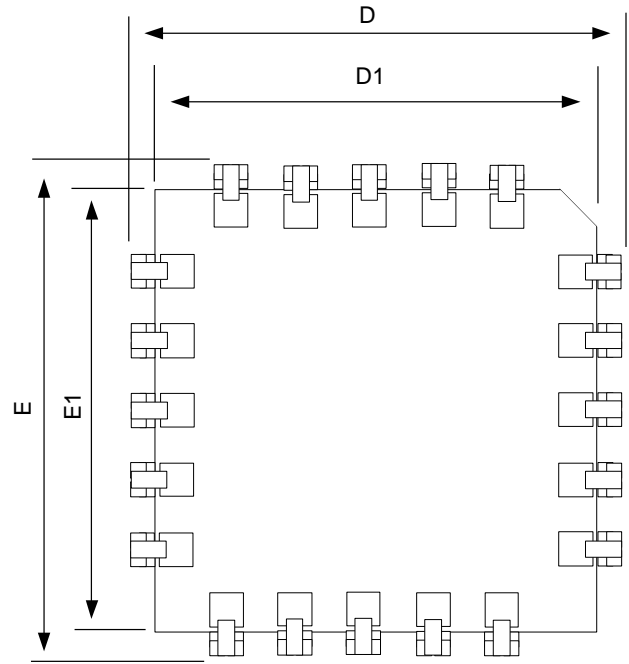
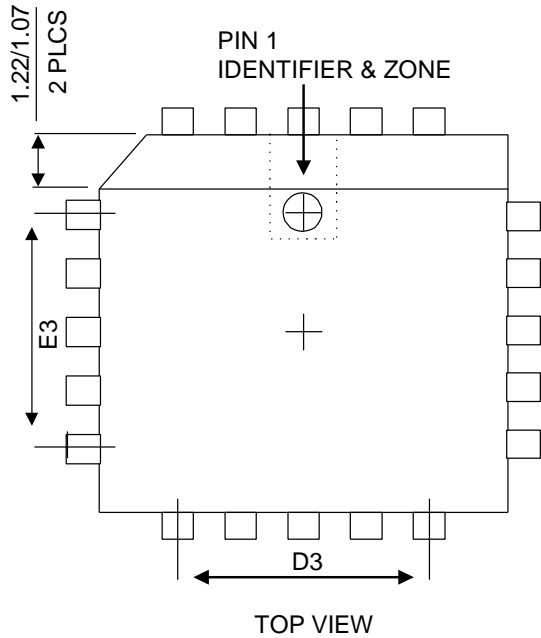

BOTTOM VIEW

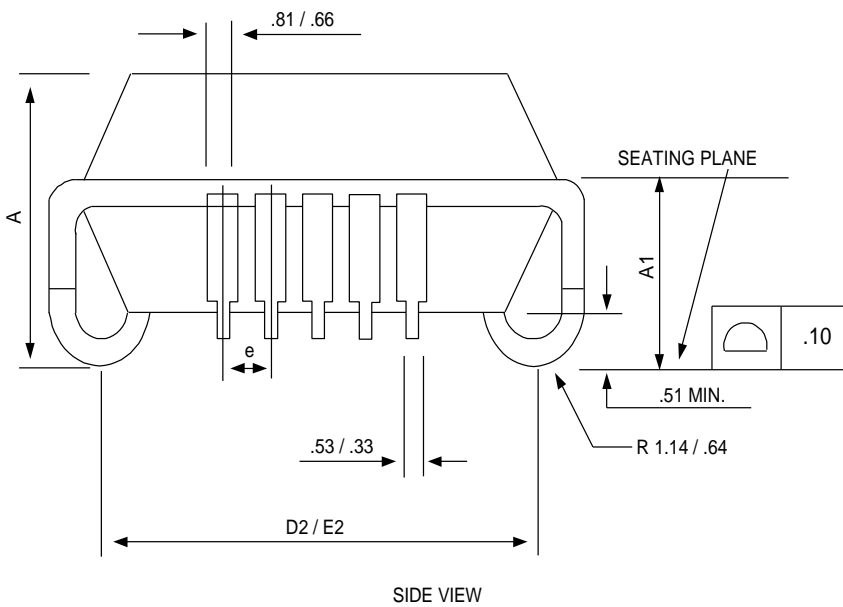

SIDE VIEW

LEAD COUNT

Symbol	68 (in Millimeters)	
	MIN	MAX
A	4.20	5.08
A1	2.29	3.30
D1	24.13	24.33
D2	22.61	23.62
D3	20.32 BSC	
E1	24.13	24.33
E2	22.61	23.62
E3	20.32 BSC	
e	1.27 BSC	
D	25.02	25.27
E	25.02	25.27

IA80C152 UNIVERSAL COMMUNICATIONS CONTROLLER

Preliminary Data Sheet

PDIP Packaging Dimensions (Theta J = TBD)

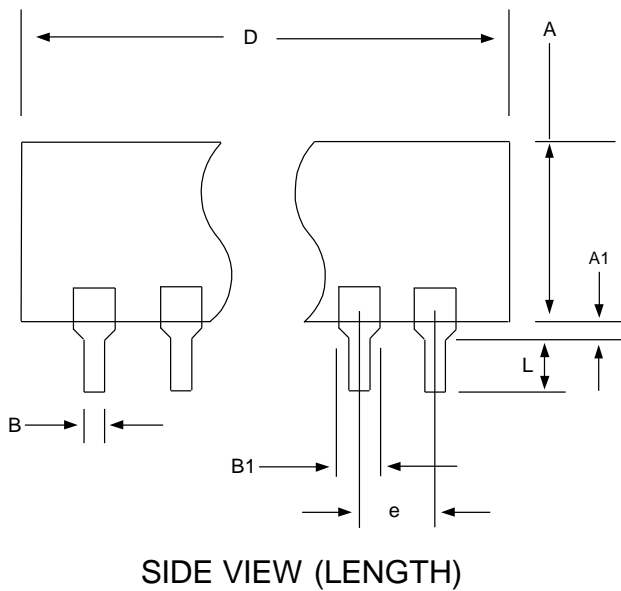
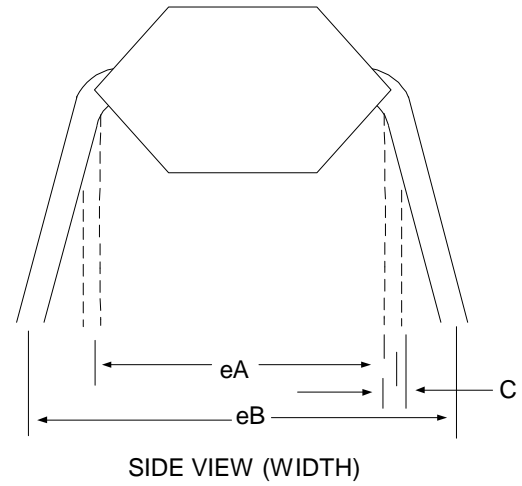
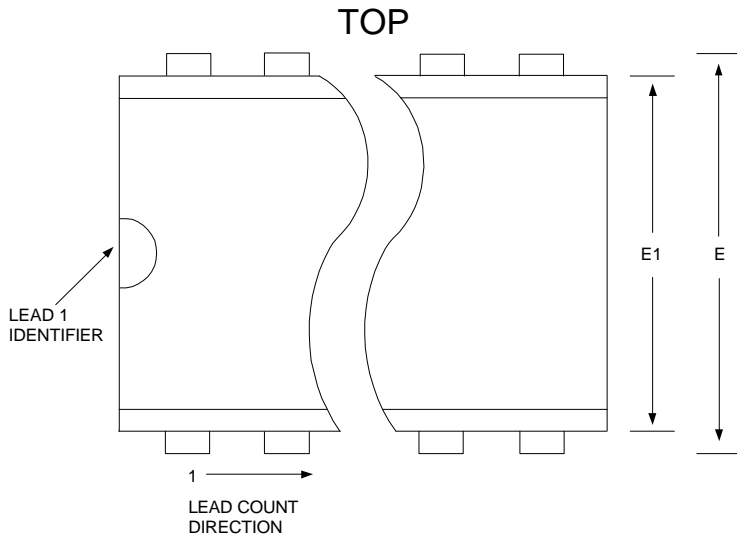

Lead Count

Symbol	48 (in Inches)	
	MIN	MAX
A	-	.200
A1	.015	-
B	.015	.020
B1	.040	.060
C	.008	.012
D	2.455	2.460
E	.580	.610
E1	.520	.560
e	.100 TYP	
eA	.580	-
eB	-	.686
L	.100 MIN	
B2	-	-
S	-	-

IA80C152 Preliminary Data Sheet

UNIVERSAL COMMUNICATIONS CONTROLLER

Packaging Options

The IA80C152 is available in four versions, two package styles, and two environmental classes as shown in the table below.

Package Type	Version	Environment	Order Number
48 Lead Plastic DIP, 600 mil wide	JA/JC	Industrial	IA80C152JA/JC-PDW48I
		Commercial	IA80C152JA/JC-PDW48C
68 Lead Plastic Leaded Chip Carrier	JA/JC	Industrial	IA80C152JA/JC-PLC68I
		Commercial	IA80C152JA/JC-PLC68C
	JB/JD	Industrial	IA80C152JB/JD-PLC68I
		Commercial	IA80C152JB/JD-PLC68C

The following diagram depicts the **innovASIC** Product Identification Number.

IAXXXX-PPPNNT/SP

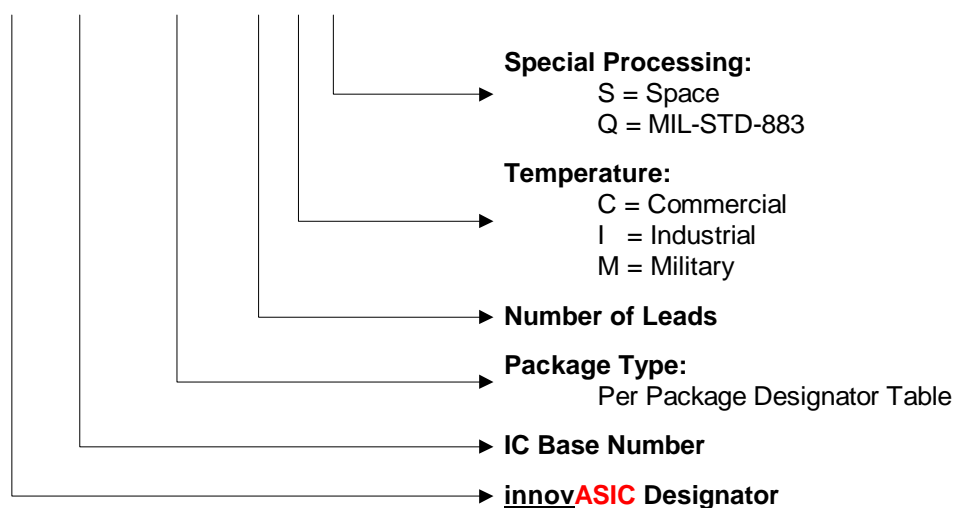

IA80C152

Preliminary Data Sheet

UNIVERSAL COMMUNICATIONS CONTROLLER

Package Designator Table	
Package Type	innovASIC Designator
Ceramic side brazed Dual In-line	CDB
Cerdip with window	CDW
Ceramic leaded chip carrier	CLC
Cerdip without window	CD
Ceramic leadless chip carrier	CLL
PLCC	PLC
Plastic DIP standard (300 mil)	PD
Plastic DIP standard (600 mil)	PDW
Plastic metric quad flat pack	PQF
Plastic thin quad flat pack	PTQ
Skinny Cerdip	CDS
Small outline plastic gull-wing(150 mil body)	PSO
Small outline medium plastic gull-wing (207 mil body)	PSM
Small outline narrow plastic gull wing (150 mil body)	PSN
Small outline wide plastic gull wing (300 mil body)	PSW
Skinny Plastic Dip	PDS
Shrink small outline plastic (5.3mm .208 body)	PS
Thin shrink small outline plastic	PTS
Small outline large plastic gull wing (330 mil body)	PSL
Thin small outline plastic gull-wing (8 x 20mm) [TSOP]	PST
PGA	CPGA
BGA	CBGA

Contact **innovASIC** for other package and processing options.