

# M80C196KB 16-BIT HIGH PERFORMANCE CHMOS MICROCONTROLLER

*Military*

- 232 Byte Register File
- Register-to-Register Architecture
- 28 Interrupt Sources/16 Vectors
- 2.3  $\mu\text{s}$  16 x 16 Multiply (12 MHz)
- 4.0  $\mu\text{s}$  32/16 Divide (12 MHz)
- Powerdown and Idle Modes
- Five 8-Bit I/O Ports
- 16-Bit Watchdog Timer
- Dynamically Configurable 8-Bit or 16-Bit Buswidth
- Available in 68-Lead PGA and 68-Lead Ceramic Quad Flat Pack
- Full Duplex Serial Port
- High Speed I/O Subsystem
- 16-Bit Timer
- 16-Bit Up/Down Counter with Capture
- Pulse-Width-Modulated Output
- Four 16-Bit Software Timers
- 10-Bit A/D Converter with S/H
- 12 MHz Version — M80C196KB
- Available in Two Product Grades:  
— MIL-STD-883,  $-55^{\circ}\text{C}$  to  $+125^{\circ}\text{C}$  ( $T_C$ )  
— Military Temperature Only (MTO),  $-55^{\circ}\text{C}$  to  $+125^{\circ}\text{C}$  ( $T_C$ )

The M80C196KB 16-bit microcontroller is a high performance member of the MCS<sup>®</sup>-96 microcontroller family. The M80C196KB is pin-for-pin compatible and uses a true superset of the M8096 instructions. Intel's CHMOS process provides a high performance processor along with low power consumption. To further reduce power requirements, the processor can be placed into Idle or Powerdown Mode.

Bit, byte, word and some 32-bit operations are available on the M80C196KB. With a 12 MHz oscillator a 16-bit addition takes 0.66  $\mu\text{s}$ , and the instruction times average 0.5  $\mu\text{s}$  to 1.5  $\mu\text{s}$  in typical applications.

Four high-speed capture inputs are provided to record times when events occur. Six high-speed outputs are available for pulse or waveform generation. The high-speed output can also generate four software timers or start an A/D conversion. Events can be based on the timer or up/down counter.

Also provided on-chip are an A/D converter with Sample and Hold, serial port, watchdog timer, and a pulse-width-modulated output signal.

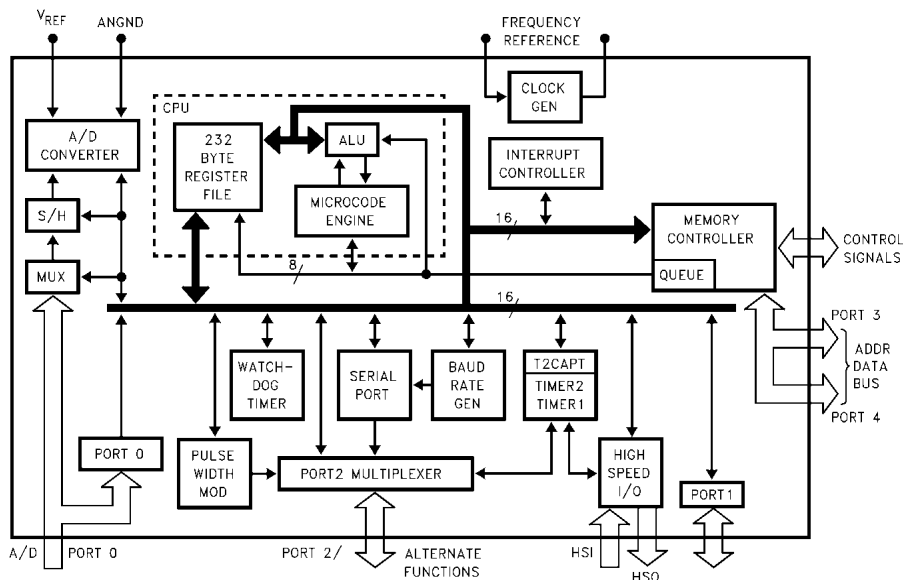

Figure 1. M80C196KB Block Diagram

271089-1

## **ARCHITECTURE**

The M80C196KB is a member of the MCS<sup>®</sup>-96 family, and as such has the same architecture and uses the same instruction set as the M8096. Many new features have been added on the M80C196KB including:

### **CPU FEATURES**

Divide by 2 instead of divide by 3 clock for 1.5X performance

Faster instructions, especially indexed/indirect data operations

2.33  $\mu$ s 16  $\times$  16 multiply with 12 MHz clock (was 6.25  $\mu$ s) on the 8096

Faster interrupt response (almost twice as fast as 8096)

Powerdown and Idle Modes

6 new instructions including Compare Long and Block Move

8 new interrupt vectors/6 new interrupt sources

### **PERIPHERAL FEATURES**

SFR Window switching allows read-only registers to be written and vice-versa

Timer2 can count up or down by external selection

Timer2 has an independent capture register

HSO line events are stored in a register

HSO has CAM Lock and CAM Clear commands

New Baud Rate values are needed for serial port, higher speeds possible in all modes

Double buffered serial port transmit register

Serial Port Receive Overrun and Framing Error Detection

PWM has a Divide-by-2 Prescaler

**NEW INSTRUCTIONS**

- PUSHA** — PUSHes the PSW, IMASK, IMASK1, and WSR  
(Used instead of PUSHF when new interrupts and registers are used.)  
assembly language format: PUSHA  
object code format: <11110100>  
bytes: 1  
states: on-chip stack: 12  
off-chip stack: 18
- POPA** — POPs the PSW, IMASK, IMASK1, and WSR  
(Used instead of POPF when new interrupts and registers are used.)  
assembly language format: POPA  
object code format: <11110101>  
bytes: 1  
states: on-chip stack: 12  
off-chip stack: 18
- IDLDP** — Sets the part into Idle or Powerdown Mode  
assembly language format: IDLPD #key (key = 1 for Idle, key = 2 for Powerdown.)  
object code format: <11110110> <key>  
bytes: 2  
states: legal key: 8  
illegal key: 25
- DJNZW** — Decrement Jump Not Zero using a Word counter  
assembly language format: DJNZW wreg, cadd  
object code format: <11100001> <wreg> <disp>  
bytes: 3  
states: jump not taken: 6  
jump taken: 10
- CMPL** — Compare 2 long direct values  
assembly language format: 

	DST	SRC
CMPL	Lreg,	Lreg

  
object code format: <11000101> <src Lreg> <dst Lreg>  
bytes: 3  
states: 7
- BMOV** — Block move using 2 auto-incrementing pointers and a counter  
assembly language format: 

	PTRS	CNTREG
BMOV	Lreg,	wreg

  
object code format: <11000001> <wreg> <Lreg>  
bytes: 3  
states: internal/internal: 8 per transfer + 6  
external/internal: 11 per transfer + 6  
external/external: 14 per transfer + 6

## SFR OPERATION

All of the registers that were present on the M8096 work the same way as they did, except that the baud rate value is different. The new registers shown in the memory map control new functions. The most important new register is the Window Select Register (WSR) which allows reading of the formerly write-only registers and vice-versa. Using the WSR is described later in this data sheet.

PACKAGING

The M80C196KB is available in a ceramic pin grid array, shown in Figure 2, and a leaded ceramic quad pack shown in Figure 3. A comparison of the pinouts for both of these package types is shown in Tables 1a–1c.

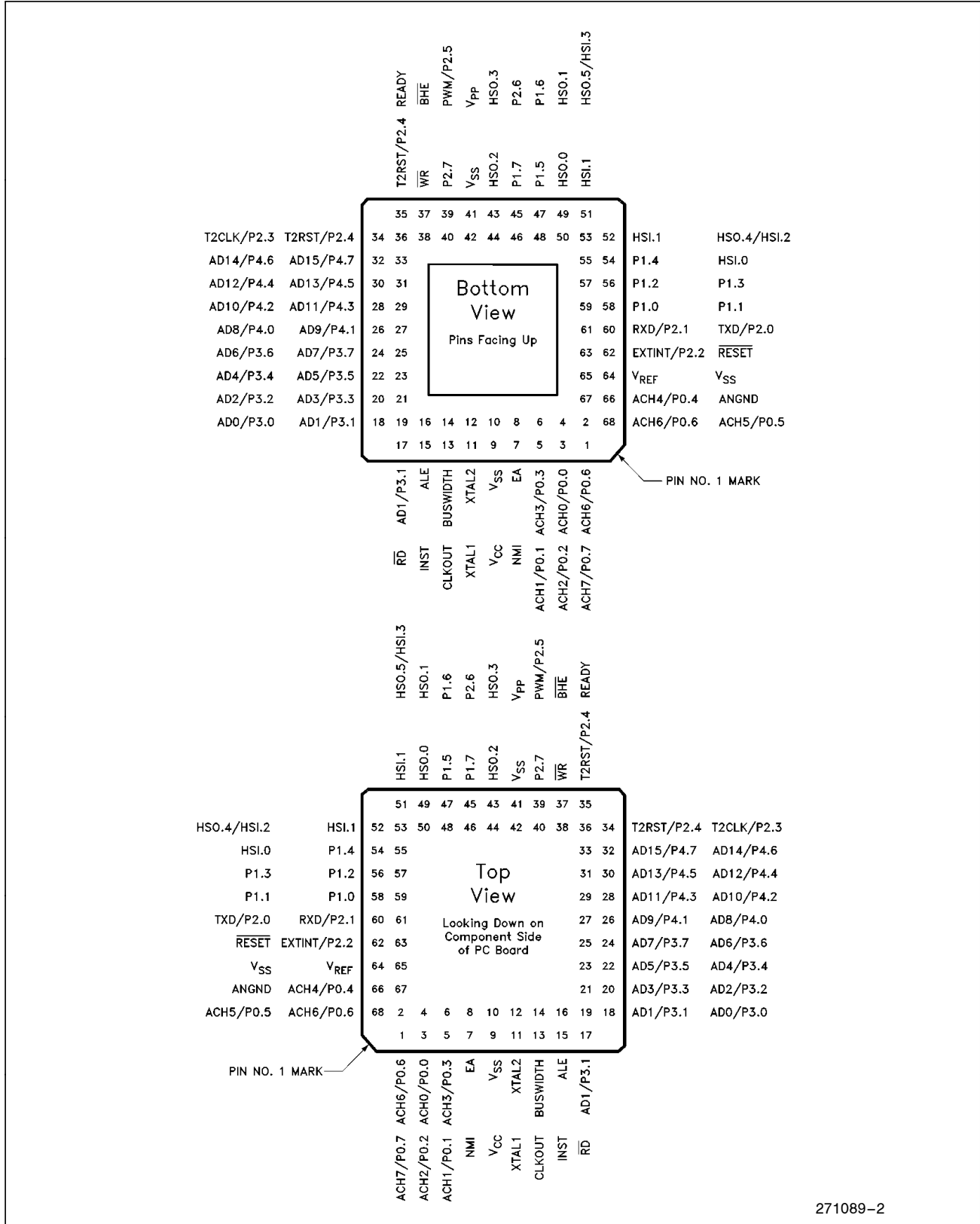

Figure 2. Pin Grid Array Pinout



**Table 1b. M80C196KB Pinout — in CQFP Pin Order**

CQFP	Signal	CQFP	Signal	CQFP	Signal
1	V <sub>CC</sub>	24	HSI.0	47	AD13/P4.5
2	$\overline{EA}$	25	HSI.1	48	AD12/P4.4
3	NMI	26	HSO.4/HSI.2	49	AD11/P4.3
4	ACH3/P0.3	27	HSO.5/HSI.3	50	AD10/P4.2
5	ACH1/P0.1	28	HSO.0	51	AD9/P4.1
6	ACH0/P0.0	29	HSO.1	52	AD8/P4.0
7	ACH2/P0.2	30	P1.5	53	AD7/P3.7
8	ACH6/P0.6	31	P1.6	54	AD6/P3.6
9	ACH7/P0.7	32	P1.7	55	AD5/P3.5
10	ACH5/P0.5	33	T2UP-DN/P2.6	56	AD4/P3.4
11	ACH4/P0.4	34	HSO.2	57	AD3/P3.3
12	ANGND	35	HSO.3	58	AD2/P3.2
13	V <sub>REF</sub>	36	V <sub>SS</sub>	59	AD1/P3.1
14	V <sub>SS</sub>	37	V <sub>PP</sub>	60	AD0/P3.0
15	EXTINT/P2.2	38	T2CAPTURE/P2.7/ $\overline{PACT}$	61	$\overline{RD}$
16	$\overline{RESET}$	39	PWM/P2.5	62	ALE/ $\overline{ADV}$
17	RXD/P2.1	40	$\overline{WR}/\overline{WRL}$	63	INST
18	TXD/P2.0	41	$\overline{BHE}/\overline{WRH}$	64	BUSWIDTH
19	P1.0	42	T2RST/P2.4/ $\overline{AINC}$	65	CLKOUT
20	P1.1	43	READY	66	XTAL2
21	P1.2	44	T2CLK/P2.3	67	XTAL1
22	P1.3	45	AD15/P4.7	68	V <sub>SS</sub>
23	P1.4	46	AD14/P4.6		

**Table 1c. M80C196KB Pinout — in Signal Order**

Signal	PGA	CQFP	Signal	PGA	CQFP	Signal	PGA	CQFP
ACH0/P0.0	4	6	T2CAPTURE/P2.7/ $\overline{PACT}$	40	38	HSI.0	54	24
ACH1/P0.1	5	5	AD0/P3.0	18	60	HSI.1	53	25
ACH2/P0.2	3	7	AD1/P3.1	19	59	$\overline{RD}$	17	61
ACH3/P0.3	6	4	AD2/P3.2	20	58	$\overline{WR}/\overline{WRL}$	38	40
ACH4/P0.4	67	11	AD3/P3.3	21	57	$\overline{BHE}/\overline{WRH}$	37	41
ACH5/P0.5	68	10	AD4/P3.4	22	56	BUSWIDTH	14	64
ACH6/P0.6	2	8	AD5/P3.5	23	55	ALE/ $\overline{ADV}$	16	62
ACH7/P0.7	1	9	AD6/P3.6	24	54	$\overline{EA}$	8	2
P1.0	59	19	AD7/P3.7	25	53	INST	15	63
P1.1	58	20	AD8/P4.0	26	52	READY	35	43
P1.2	57	21	AD9/P4.1	27	51	NMI	7	3
P1.3	56	22	AD10/P4.2	28	50	$\overline{RESET}$	62	16
P1.4	55	23	AD11/P4.3	29	49	XTAL1	11	67
P1.5	48	30	AD12/P4.4	30	48	XTAL2	12	66
P1.6	47	31	AD13/P4.5	31	47	CLKOUT	13	65
P1.7	46	32	AD14/P4.6	32	46	ANGND	66	12
TXD/P2.0	60	18	AD15/P4.7	33	45	V <sub>REF</sub>	65	13
RXD/P2.1	61	17	HSO.0	50	28	V <sub>PP</sub>	41	37
EXTINT/P2.2	63	15	HSO.1	49	29	V <sub>CC</sub>	9	1
T2CLK/P2.3	34	44	HSO.2	44	34	V <sub>SS</sub>	10	68
T2RST/P2.4/ $\overline{AINC}$	36	42	HSO.3	43	35	V <sub>SS</sub>	42	36
PWM/P2.5	39	39	HSO.4/HSI.2	52	26	V <sub>SS</sub>	64	14
T2UP-DN/P2.6	45	33	HSO.5/HSI.3	51	27			

## PIN DESCRIPTIONS

Symbol	Name and Function
V <sub>CC</sub>	Main supply voltage (5V).
V <sub>SS</sub>	Digital circuit ground (0V). There are three V <sub>SS</sub> pins, all of which must be connected.
V <sub>REF</sub>	Reference voltage for the A/D converter (5V). V <sub>REF</sub> is also the supply voltage to the analog portion of the A/D converter and the logic used to read Port 0. Must be connected for A/D and Port 0 to function.
ANGND	Reference ground for the A/D converter. Must be held at nominally the same potential as V <sub>SS</sub> .
V <sub>PP</sub>	Timing pin for the return from powerdown circuit. Connect this pin with a 1 $\mu$ F capacitor to V <sub>SS</sub> and a 1 M $\Omega$ resistor to V <sub>CC</sub> . If this function is not used V <sub>PP</sub> may be tied to V <sub>CC</sub> . This pin was V <sub>BB</sub> on the 8X9X-90 parts and is the programming voltage on EPROM part.
XTAL1	Input of the oscillator inverter and of the internal clock generator.
XTAL2	Output of the oscillator inverter.
CLKOUT	Output of the internal clock generator. The frequency of CLKOUT is 1/2 the oscillator frequency. It has a 50% duty cycle.
$\overline{\text{RESET}}$	Reset input to the chip. Input low for at least 4 state times to reset the chip. The subsequent low-to-high transition re-synchronizes CLKOUT and commences a 10-state-time sequence in which the PSW is cleared, a byte read from 2018H loads CCR, and a jump to location 2080H is executed. Input high for normal operation. $\overline{\text{RESET}}$ has an internal pullup.
BUSWIDTH	Input for buswidth selection. If CCR bit 1 is a one, this pin selects the bus width for the bus cycle in progress. If BUSWIDTH is a 1, a 16-bit bus cycle occurs. If BUSWIDTH is a 0 an 8-bit cycle occurs. If CCR bit 1 is a 0, the bus is always an 8-bit bus. This pin is the $\overline{\text{TEST}}$ pin on 8X9X-90 parts. Systems with $\overline{\text{TEST}}$ tied to V <sub>CC</sub> do not need to change.



**PIN DESCRIPTIONS** (Continued)

Symbol	Name and Function
NMI	A positive transition causes a vector through 203EH.
INST	Output high during an external memory read indicates the read is an instruction fetch. INST is valid throughout the bus cycle. INST is activated only during external memory accesses and output low for a data fetch.
$\overline{EA}$	$\overline{EA}$ must be equal to a TTL-low to cause address locations 2000H through 3FFFH to be directed to off-chip memory.
ALE/ $\overline{ADV}$	Address Latch Enable or Address Valid output, as selected by CCR. Both pin options provide a latch to demultiplex the address from the address/data bus. When the pin is $\overline{ADV}$ , it goes inactive high at the end of the bus cycle. $\overline{ADV}$ can be used as a chip select for external memory. ALE/ $\overline{ADV}$ is activated only during external memory accesses.
$\overline{RD}$	Read signal output to external memory. $\overline{RD}$ is activated only during external memory reads.
$\overline{WR}/\overline{WRL}$	Write and Write Low output to external memory, as selected by the CCR. $\overline{WR}$ will go low for every external write, while $\overline{WRL}$ will go low only for external writes where an even byte is being written. $\overline{WR}/\overline{WRL}$ is activated only during external memory writes.
$\overline{BHE}/\overline{WRH}$	Bus High Enable or Write High output to external memory, as selected by the CCR. $\overline{BHE} = 0$ selects the bank of memory that is connected to the high byte of the data bus. $A0 = 0$ selects the bank of memory that is connected to the low byte of the data bus. Thus accesses to a 16-bit wide memory can be to the low byte only ( $A0 = 0, \overline{BHE} = 1$ ), to the high byte only ( $A0 = 1, \overline{BHE} = 0$ ), or both bytes ( $A0 = 0, \overline{BHE} = 0$ ). If the $\overline{WRH}$ function is selected, the pin will go low if the bus cycle is writing to an odd memory location. $\overline{BHE}/\overline{WRH}$ is valid only during 16-bit external memory write cycles.
READY	Ready input to lengthen external memory cycles, for interfacing to slow or dynamic memory, or for bus sharing. If the pin is high, CPU operation continues in a normal manner. If the pin is low prior to the falling edge of CLKOUT, the memory controller goes into a wait mode until the next positive transition in CLKOUT occurs with READY high. When the external memory is not being used, READY has no effect. Internal control of the number of wait states inserted into a bus cycle held not ready is available through configuration of CCR.
HSI	Inputs to High Speed Input Unit. Four HSI pins are available: HSI.0, HSI.1, HSI.2, and HSI.3. Two of them (HSI.2 and HSI.3) are shared with the HSO Unit.
HSO	Outputs from High Speed Output Unit. Six HSO pins are available: HSO.0, HSO.1, HSO.2, HSO.3, HSO.4, and HSO.5. Two of them (HSO.4 and HSO.5) are shared with the HSI Unit.
Port 0	8-bit high impedance input-only port. Three pins can be used as digital inputs and/or as analog inputs to the on-chip A/D converter.
Port 1	8-bit quasi-bidirectional I/O port.
Port 2	8-bit multi-functional port. All of its pins are shared with other functions in the M80C196KB.
Ports 3 and 4	8-bit bi-directional I/O ports with open drain outputs. These pins are shared with the multiplexed address/data bus which has strong internal pullups.

## Instruction Summary

Mnemonic	Operands	Operation (Note 1)	Flags						Notes
			Z	N	C	V	VT	ST	
ADD/ADDB	2	$D \leftarrow D + A$	✓	✓	✓	✓	↑	–	
ADD/ADDB	3	$D \leftarrow B + A$	✓	✓	✓	✓	↑	–	
ADDC/ADDCB	2	$D \leftarrow D + A + C$	↓	✓	✓	✓	↑	–	
SUB/SUBB	2	$D \leftarrow D - A$	✓	✓	✓	✓	↑	–	
SUB/SUBB	3	$D \leftarrow B - A$	✓	✓	✓	✓	↑	–	
SUBC/SUBCB	2	$D \leftarrow D - A + C - 1$	↓	✓	✓	✓	↑	–	
CMP/CMPB	2	$D - A$	✓	✓	✓	✓	↑	–	
MUL/MULU	2	$D, D + 2 \leftarrow D \times A$	–	–	–	–	–	–	2
MUL/MULU	3	$D, D + 2 \leftarrow B \times A$	–	–	–	–	–	–	2
MULB/MULUB	2	$D, D + 1 \leftarrow D \times A$	–	–	–	–	–	–	3
MULB/MULUB	3	$D, D + 1 \leftarrow B \times A$	–	–	–	–	–	–	3
DIVU	2	$D \leftarrow (D, D + 2) / A, D + 2 \leftarrow \text{remainder}$	–	–	–	✓	↑	–	2
DIVUB	2	$D \leftarrow (D, D + 1) / A, D + 1 \leftarrow \text{remainder}$	–	–	–	✓	↑	–	3
DIV	2	$D \leftarrow (D, D + 2) / A, D + 2 \leftarrow \text{remainder}$	–	–	–	✓	↑	–	
DIVB	2	$D \leftarrow (D, D + 1) / A, D + 1 \leftarrow \text{remainder}$	–	–	–	✓	↑	–	
AND/ANDB	2	$D \leftarrow D \text{ AND } A$	✓	✓	0	0	–	–	
AND/ANDB	3	$D \leftarrow B \text{ AND } A$	✓	✓	0	0	–	–	
OR/ORB	2	$D \leftarrow D \text{ OR } A$	✓	✓	0	0	–	–	
XOR/XORB	2	$D \leftarrow D \text{ (excl. or) } A$	✓	✓	0	0	–	–	
LD/LDB	2	$D \leftarrow A$	–	–	–	–	–	–	
ST/STB	2	$A \leftarrow D$	–	–	–	–	–	–	
LDBSE	2	$D \leftarrow A; D + 1 \leftarrow \text{SIGN}(A)$	–	–	–	–	–	–	3,4
LDBZE	2	$D \leftarrow A; D + 1 \leftarrow 0$	–	–	–	–	–	–	3,4
PUSH	1	$SP \leftarrow SP - 2; (SP) \leftarrow A$	–	–	–	–	–	–	
POP	1	$A \leftarrow (SP); SP + 2$	–	–	–	–	–	–	
PUSHF	0	$SP \leftarrow SP - 2; (SP) \leftarrow \text{PSW};$ $\text{PSW} \leftarrow 0000\text{H}; I \leftarrow 0$	0	0	0	0	0	0	
POPF	0	$\text{PSW} \leftarrow (SP); SP \leftarrow SP + 2; I \leftarrow \text{✓}$	✓	✓	✓	✓	✓	✓	
SJMP	1	$PC \leftarrow PC + 11\text{-bit offset}$	–	–	–	–	–	–	5
LJMP	1	$PC \leftarrow PC + 16\text{-bit offset}$	–	–	–	–	–	–	5
BR[indirect]	1	$PC \leftarrow (A)$	–	–	–	–	–	–	
SCALL	1	$SP \leftarrow SP - 2;$ $(SP) \leftarrow PC; PC \leftarrow PC + 11\text{-bit offset}$	–	–	–	–	–	–	5
LCALL	1	$SP \leftarrow SP - 2; (SP) \leftarrow PC;$ $PC \leftarrow PC + 16\text{-bit offset}$	–	–	–	–	–	–	5

**Instruction Summary (Continued)**

Mnemonic	Operands	Operation (Note 1)	Flags						Notes
			Z	N	C	V	VT	ST	
RET	0	PC ← (SP); SP ← SP + 2	–	–	–	–	–	–	
J (conditional)	1	PC ← PC + 8-bit offset (if taken)	–	–	–	–	–	–	5
JC	1	Jump if C = 1	–	–	–	–	–	–	5
JNC	1	jump if C = 0	–	–	–	–	–	–	5
JE	1	jump if Z = 1	–	–	–	–	–	–	5
JNE	1	Jump if Z = 0	–	–	–	–	–	–	5
JGE	1	Jump if N = 0	–	–	–	–	–	–	5
JLT	1	Jump if N = 1	–	–	–	–	–	–	5
JGT	1	Jump if N = 0 and Z = 0	–	–	–	–	–	–	5
JLE	1	Jump if N = 1 or Z = 1	–	–	–	–	–	–	5
JH	1	Jump if C = 1 and Z = 0	–	–	–	–	–	–	5
JNH	1	Jump if C = 0 or Z = 1	–	–	–	–	–	–	5
JV	1	Jump if V = 0	–	–	–	–	–	–	5
JNV	1	Jump if V = 1	–	–	–	–	–	–	5
JVT	1	Jump if VT = 1; Clear VT	–	–	–	–	0	–	5
JNVT	1	Jump if VT = 0; Clear VT	–	–	–	–	0	–	5
JST	1	Jump if ST = 1	–	–	–	–	–	–	5
JNST	1	Jump if ST = 0	–	–	–	–	–	–	5
JBS	3	Jump if Specified Bit = 1	–	–	–	–	–	–	5,6
JBC	3	Jump if Specified Bit = 0	–	–	–	–	–	–	5,6
DJNZ/ DJNZW	1	D ← D – 1; If D ≠ 0 then PC ← PC + 8-bit offset	–	–	–	–	–	–	5
DEC/DECB	1	D ← D – 1	✓	✓	✓	✓	↑	–	
NEG/NEGB	1	D ← 0 – D	✓	✓	✓	✓	↑	–	
INC/INCB	1	D ← D + 1	✓	✓	✓	✓	↑	–	
EXT	1	D ← D; D + 2 ← Sign (D)	✓	✓	0	0	–	–	2
EXTB	1	D ← D; D + 1 ← Sign (D)	✓	✓	0	0	–	–	3
NOT/NOTB	1	D ← Logical Not (D)	✓	✓	0	0	–	–	
CLR/CLRB	1	D ← 0	1	0	0	0	–	–	
SHL/SHLB/SHLL	2	C ← msb - - - - - lsb ← 0	✓	✓	✓	✓	↑	–	7
SHR/SHRB/SHRL	2	0 → msb - - - - - lsb → C	✓	✓	✓	0	–	✓	7
SHRA/SHRAB/SHRAL	2	msb → msb - - - - - lsb → C	✓	✓	✓	0	–	✓	7
SETC	0	C ← 1	–	–	1	–	–	–	
CLRC	0	C ← 0	–	–	0	–	–	–	

**Instruction Summary** (Continued)

Mnemonic	Operands	Operation (Note 1)	Flags						Notes
			Z	N	C	V	VT	ST	
CLRVT	0	$VT \leftarrow 0$	–	–	–	–	0	–	
RST	0	$PC \leftarrow 2080H$	0	0	0	0	0	0	8
DI	0	Disable All Interupts ( $I \leftarrow 0$ )	–	–	–	–	–	–	
EI	0	Enable All Interupts ( $I \leftarrow 1$ )	–	–	–	–	–	–	
NOP	0	$PC \leftarrow PC + 1$	–	–	–	–	–	–	
SKIP	0	$PC \leftarrow PC + 2$	–	–	–	–	–	–	
NORML	2	Left shift till msb = 1; $D \leftarrow$ shift count	✓	✓	0	–	–	–	7
TRAP	0	$SP \leftarrow SP - 2$ ; $(SP) \leftarrow PC$ ; $PC \leftarrow (2010H)$	–	–	–	–	–	–	9
PUSHA	1	$SP \leftarrow SP - 2$ ; $(SP) \leftarrow PSW$ ; $PSW \leftarrow 0000H$ ; $SP \leftarrow SP - 2$ ; $(SP) \leftarrow IMASK1/WSR$ ; $IMASK1 \leftarrow 00H$	0	0	0	0	0	0	
POPA	1	$IMASK1/WSR \leftarrow (SP)$ ; $SP \leftarrow SP + 2$ $PSW \leftarrow (SP)$ ; $SP \leftarrow SP + 2$	✓	✓	✓	✓	✓	✓	
IDLPD	1	IDLE MODE IF KEY = 1; POWERDOWN MODE IF KEY = 2; CHIP RESET OTHERWISE	–	–	–	–	–	–	
CMPL	2	D-A	✓	✓	✓	✓	↑	–	
BMOV	2	$[PTR\_HI] + \leftarrow [PTR\_LOW] + ;$ UNTIL COUNT = 0	–	–	–	–	–	–	

**NOTES:**

1. If the mnemonic ends in "B" a byte operation is performed, otherwise a word operation is done. Operands D, B, and A must conform to the alignment rules for the required operand type. D and B are locations in the Register File; A can be located anywhere in memory.
2. D, D + 2 are consecutive WORDS in memory; D is DOUBLE-WORD aligned.
3. D, D + 1 are consecutive BYTES in memory; D is WORD aligned.
4. Changes a byte to word.
5. Offset is a 2's complement number.
6. Specified bit is one of the 2048 bits in the register file.
7. The "L" (Long) suffix indicates double-word operation.
8. Initiates a Reset by pulling RESET low. Software should re-initialize all the necessary registers with code starting at 2080H.
9. The assembler will not accept this mnemonic.

**Instruction Execution State Times (Minimum) (1)**

MNEMONIC	DIRECT	IMMED	INDIRECT		INDEXED	
			NORMAL*	A-INC*	SHORT*	LONG*
ADD (3-op)	5	6	7/10	8/11	7/10	8/11
SUB (3-op)	5	6	7/10	8/11	7/10	8/11
ADD (2-op)	4	5	6/8	7/9	6/8	7/9
SUB (2-op)	4	5	6/8	7/9	6/8	7/9
ADDC	4	5	6/8	7/9	6/8	7/9
SUBC	4	5	6/8	7/9	6/8	7/9
CMP	4	5	6/8	7/9	6/8	7/9
ADDB (3-op)	5	5	7/10	8/11	7/10	8/11
SUBB (3-op)	5	5	7/10	8/11	7/10	8/11
ADDB (2-op)	4	4	6/8	7/9	6/8	7/9
SUBB (2-op)	4	4	6/8	7/9	6/8	7/9
ADDCB	4	4	6/8	7/9	6/8	7/9
SUBCB	4	4	6/8	7/9	6/8	7/9
CMPB	4	4	6/8	7/9	6/8	7/9
MUL (3-op)	16	17	18/21	19/22	19/22	20/23
MULU (3-op)	14	15	16/19	17/19	17/20	18/21
MUL (2-op)	16	17	18/21	19/22	19/22	20/23
MULU (2-op)	14	15	16/19	17/19	17/20	18/21
DIV	26	27	28/31	29/32	29/32	30/33
DIVU	24	25	26/29	27/30	27/30	28/31
MULB (3-op)	12	12	14/17	15/18	15/18	16/19
MULUB (3-op)	10	10	12/15	13/15	12/16	14/17
MULB (2-op)	12	12	14/17	15/18	15/18	16/19
MULUB (2-op)	10	10	12/15	13/15	12/16	14/17
DIVB	18	18	20/23	21/24	21/24	22/25
DIVUB	16	16	18/21	19/22	19/22	20/23
AND (3-op)	5	6	7/10	8/11	7/10	8/11
AND (2-op)	4	5	6/8	7/9	6/8	7/9
OR (2-op)	4	5	6/8	7/9	6/8	7/9
XOR	4	5	6/8	7/9	6/8	7/9
ANDB (3-op)	5	5	7/10	8/11	7/10	8/11
ANDB (2-op)	4	4	6/8	7/9	6/8	7/9
ORB (2-op)	4	4	6/8	7/9	6/8	7/9
XORB	4	4	6/8	7/9	6/8	7/9
LD/LDB	4	5	5/8	6/8	6/9	7/10
ST/STB	4	5	5/8	6/9	6/9	7/10
LDBSE	4	4	5/8	6/8	6/9	7/10
LDBZE	4	4	5/8	6/8	6/9	7/10
BMOV	6 + 8 per word			6 + 11/14 per word		
PUSH (int stack)	6	7	9/12	10/13	10/13	11/14
POP (int stack)	8	—	10/12	11/13	11/13	12/14
PUSH (ext stack)	8	9	11/14	12/15	12/15	13/16
POP (ext stack)	11	—	13/15	14/16	14/16	15/17

\*Times for (Internal/External) Operands

**NOTE:**

1. Execution times for instructions accessing external data memory may be one to two states higher depending on the instruction stream being executed. In sixteen bit mode, the minimum execution state times apply for instructions accessing internal register space. Execution times do not reflect eight bit mode or insertion of wait states.

**Instruction Execution State Times** (Continued)

<b>MNEMONIC</b>		<b>MNEMONIC</b>	
PUSHF (int stack)	6	PUSHF (ext stack)	8
POPF (int stack)	7	POPF (ext stack)	10
PUSHA (int stack)	12	PUSHA (ext stack)	18
POPA (int stack)	12	POPA (ext stack)	18
TRAP (int stack)	16	TRAP (ext stack)	18
LCALL (int stack)	11	LCALL (ext stack)	13
SCALL (int stack)	11	SCALL (ext stack)	13
RET (int stack)	11	RET (ext stack)	14
CMPL	7	DEC/DECB	3
CLR/CLRB	3	EXT/EXTB	4
NOT/NOTB	3	INC/INCB	3
NEG/NEGB	3		
LJMP	7		
SJMP	7		
BR [indirect]	7		
JNST, JST	4/8 jump not taken/jump taken		
JNH, JH	4/8 jump not taken/jump taken		
JGT, JLE	4/8 jump not taken/jump taken		
JNC, JC	4/8 jump not taken/jump taken		
JNVT, JVT	4/8 jump not taken/jump taken		
JNV, JV	4/8 jump not taken/jump taken		
JGE, JLT	4/8 jump not taken/jump taken		
JNE, JE	4/8 jump not taken/jump taken		
JBC, JBS	5/9 jump not taken/jump taken		
DJNZ	5/9 jump not taken/jump taken		
DJNZW	5/9 jump not taken/jump taken		
NORML	8 + 1 per shift (9 for 0 shift)		
SHRL	7 + 1 per shift (8 for 0 shift)		
SHLL	7 + 1 per shift (8 for 0 shift)		
SHRAL	7 + 1 per shift (8 for 0 shift)		
SHR/SHRB	6 + 1 per shift (7 for 0 shift)		
SHL/SHLB	6 + 1 per shift (7 for 0 shift)		
SHRA/SHRAB	6 + 1 per shift (7 for 0 shift)		
CLRC	2		
SETC	2		
DI	2		
EI	2		
CLRVT	2		
NOP	2		
RST	15 (includes fetch of configuration byte)		
SKIP	3		
IDLPD	8/25 (proper key/improper key)		

**MEMORY MAP**

EXTERNAL MEMORY OR I/O	0FFFFH
INTERNAL ROM/EPROM OR EXTERNAL MEMORY	4000H
RESERVED	2080H
UPPER 8 INTERRUPT VECTORS	2040H
ROM/EPROM SECURITY KEY*	2030H
RESERVED	2020H
CHIP CONFIGURATION BYTE	2019H
RESERVED	2018H
LOWER 8 INTERRUPT VECTORS PLUS 2 SPECIAL INTERRUPTS	2014H
PORT 3 AND PORT 4	2000H
EXTERNAL MEMORY OR I/O	1FFEH
EXTERNAL MEMORY OR I/O	0100H
INTERNAL DATA MEMORY - REGISTER FILE (STACK POINTER, RAM AND SFRS) EXTERNAL PROGRAM CODE MEMORY	0000H

\*ROM/EPROM is available for the 80C196

**M80C196KB INTERRUPTS**

Number	Source	Vector Location	Priority
INT15	NMI	203EH	15
INT14	HSI FIFO Full	203CH	14
INT13	EXTINT Pin	203AH	13
INT12	TIMER2 Overflow	2038H	12
INT11	TIMER2 Capture	2036H	11
INT10	4th Entry into HSI FIFO	2034H	10
INT09	RI	2032H	9
INT08	TI	2030H	8
SPECIAL	Unimplemented Opcode	2012H	N/A
SPECIAL	Trap	2010H	N/A
INT07	EXTINT	200EH	7
INT06	Serial Port	200CH	6
INT05	Software Timer	200AH	5
INT04	HSI.0 Pin	2008H	4
INT03	High Speed Outputs	2006H	3
INT02	HSI Data Available	2004H	2
INT01	A/D Conversion Complete	2002H	1
INT00	Timer Overflow	2000H	0

Address	Register Name	Address	Register Name
19H	STACK POINTER	19H	STACK POINTER
18H		18H	
17H	*IOS2	17H	PWM_CONTROL
16H	IOS1	16H	IOC1
15H	IOS0	15H	IOC0
14H	*WSR	14H	*WSR
13H	*INT_MASK 1	13H	*INT_MASK 1
12H	*INT_PEND 1	12H	*INT_PEND 1
11H	*SP_STAT	11H	*SP_CON
10H	PORT2	10H	PORT2
0FH	PORT1	0FH	PORT1
0EH	PORT0	0EH	BAUD RATE
0DH	TIMER2 (HI)	0DH	TIMER2 (HI)
0CH	TIMER2 (LO)	0CH	TIMER2 (LO)
0BH	TIMER1 (HI)	0BH	*IOC2
0AH	TIMER1 (LO)	0AH	WATCHDOG
09H	INT_PENDING	09H	INT_PENDING
08H	INT_MASK	08H	INT_MASK
07H	SBUF(RX)	07H	SBUF(TX)
06H	HSI_STATUS	06H	HSO_COMMAND
05H	HSI_TIME (HI)	05H	HSO_TIME (HI)
04H	HSI_TIME (LO)	04H	HSO_TIME (LO)
03H	AD_RESULT (HI)	03H	HSI_MODE
02H	AD_RESULT (LO)	02H	AD_COMMAND
01H	ZERO REG (HI)	01H	ZERO REG (HI)
00H	ZERO REG (LO)	00H	ZERO REG (LO)

WHEN READ

WSR = 0

WHEN WRITTEN

WSR = 15

0FH	RESERVED (1)
0EH	RESERVED (1)
0DH	*T2 CAPTURE (HI)
0CH	*T2 CAPTURE (LO)

WSR = 15

OTHER SFRS IN WSR 15 BECOME READABLE IF THEY WERE WRITABLE IN WSR = 0 AND WRITABLE IF THEY WERE READABLE IN WSR = 0

\*NEW OR CHANGED REGISTER FUNCTION

**NOTE:**  
1. Reserved registers should not be written.

## USING THE ALTERNATE REGISTER WINDOW (WSR = 15)

I/O register expansion on the new CHMOS members of the MCS-96 family has been provided by making two register windows available. Switching between these windows is done using the Window Select Register (WSR). The PUSH and POP instructions can be used to push and pop the WSR and second interrupt mask when entering or leaving interrupts, so it is easy to change between windows.

On the M80C196KB only Window 0 and Window 15 are active. Window 0 is a true superset of the standard 8096 SFR space, while Window 15 allows the read-only registers to be written and write-only registers to be read. The only major exception to this is the Timer2 register which is the Timer2 capture register in Window 15. The writeable register for Timer2 is in Window 0. There are also some minor changes and cautions. The descriptions of the registers which have different functions in Window 15 than in Window 0 are listed below:

AD_COMMAND (02H)	— Read the last written command
AD_RESULT (02H, 03H)	— Write a value into the result register
HSI_MODE (03H)	— Read the value in HSI_MODE
HSI_TIME (04H, 05H)	— Write to FIFO Holding register
HSD_TIME (04H, 05H)	— Read the last value placed in the holding register
HSI_STATUS (06H)	— Write to status bits but not to HSI pin bits. (Pin bits are 1,3,5,7).
HSD_COMMAND (06H)	— Read the last value placed in the holding register
SBUF(RX) (07H)	— Write a value into the receive buffer
SBUF(TX) (07H)	— Read the last value written to the transmit buffer
WATCHDOG(0AH)	— Read the value in the upper byte of the WDT
TIMER1 (0AH, 0BH)	— Write a value to Timer1
TIMER2 (0CH, 0DH)	— Read/Write the Timer2 capture register. Note that Timer2 read/write is done with WSR = 0.
IOC2 (0BH)	— Last written value is readable, except bit 7 (note 1)
BAUD_RATE (0EH)	— No function, cannot be read
PORT0 (0EH)	— No function, no output drivers on the pins. Register reserved.
PORT1	— IOPORT1 cannot be read or written in Window 15. Register reserved.
SP_STAT (11H)	— Set the status bits, TI and RI can be set, but it will not cause an interrupt
SP_CON (11H)	— Read the current control byte
IOS0 (15H)	— Writing to this register controls the HSO pins. Bits 6 and 7 are inactive for writes.
IOC0 (15H)	— Last written value is readable, except bit 1 (note 1)
IOS1 (16H)	— Writing to this register will set the status bits, but not cause interrupts. Bits 6 and 7 are not functional
IOC1 (16H)	— Last written value is readable
IOS2 (17H)	— Writing to this register will set the status bits, but not cause interrupts.
PWM_CONTROL (17H)	— Read the duty cycle value written to PWM_CONTROL

### NOTE:

1. IOC2.7 (CAM CLEAR) and IOC0.1 (T2RST) are not latched and will read as a 1 (precharged bus) .

Being able to write to the read-only registers and vice-versa provides a lot of flexibility. One of the most useful advantages is the ability to set the timers and HSO lines for initial conditions other than zero.

Reserved registers may be used for testing as future features. Do not write to these registers. Read from reserved registers will return indeterminate values.



## SFR BIT SUMMARY

A summary of the SFRs which control I/O functions has been included in this section. The summary is separated into a list of those SFRs which have changed on the M80C196KB and a list of those which have remained almost the same.

The following M80C196KB SFRs are different than those on the M8096BH:

(The Read and Write comments indicate the register's function in Window 0 unless otherwise specified.)

**SBUF(TX):** Now double buffered

07h  
write

**BAUD RATE:** Uses new Baud Rate Values

0Eh  
write

**SP\_STAT:**

7	6	5	4	3	2	1	0
RB8/ RPE	RI	TI	FE	TXE	OE	X	X

11h  
read

RPE : Receive Parity Error  
 RI : Receive Indicator  
 TI : Transmit Indicator  
 FE : Framing Error  
 TXE : Transmitter Empty  
 OE : Receive Overrun Error

**IPEND1:  
IMASK1:**

7	6	5	4	3	2	1	0
NMI	FIFO FULL	EXT INT	T2 OVF	T2 CAP	HSI4	RI	TI

12h,13h  
read/write

NMI : Non-Maskable Interrupt (set to 0 for future compatibility)  
 FIFO FULL : HSIO FIFO full  
 EXTINT : External Interrupt Pin  
 T2OVF : Timer2 Overflow  
 T2CAP : Timer2 Capture  
 HSI4 : HSI has 4 or more entries in FIFO  
 RI : Receive Interrupt  
 TI : Transmit Interrupt

**WSR:**

7	6	5	4	3	2	1	0
0	0	0	0	W	W	W	W

14h  
read/write

WWWW = 0 : SFRs function like a superset of M8096 SFRs

WWWW = 14 : PPW register

WWWW = 15 : Exchange read/write registers

WWWW = OTHER : Undefined, do not use

0000 : These bits must always be written as zeros to provide compatibility with future products.

**IOS2:**

7	6	5	4	3	2	1	0
START A2D	T2 RESET	HSO.5	HSO.4	HSO.3	HSO.2	HSO.1	HSO.0

17h  
read

Indicates which HSO event occurred

START A2D : HSO\_CMD 15, start A to D

T2RESET : HSO\_CMD 14, Timer 2 reset

HSO.0-5 : Output pins HSO.0 through HSO.5

**IOC2:**

7	6	5	4	3	2	1	0
CLEAR CAM	ENA LOCK	T2ALT INT	A2D CPD	X	SLOW PWM	T2UD ENA	FAST T2EN

0Bh  
write

CLEAR\_CAM : Clear Entire CAM

ENA\_LOCK : Enable lockable CAM entry feature

T2ALT INT : Enable T2 Alternate Interrupt at 8000H

A2D\_CPD : Clock Prescale Disable for low XTAL frequency (A to D conversion in fewer state times)

X : Set to 0

SLOW\_PWM : Turn on divide by 2 Prescaler on PWM

T2UD ENA : Enable Timer 2 as up/down counter

FAST\_T2EN : Enable Fast increment of T2; once per state time.

The following registers are the same on the M80C196KB as they were on the M8096BH:

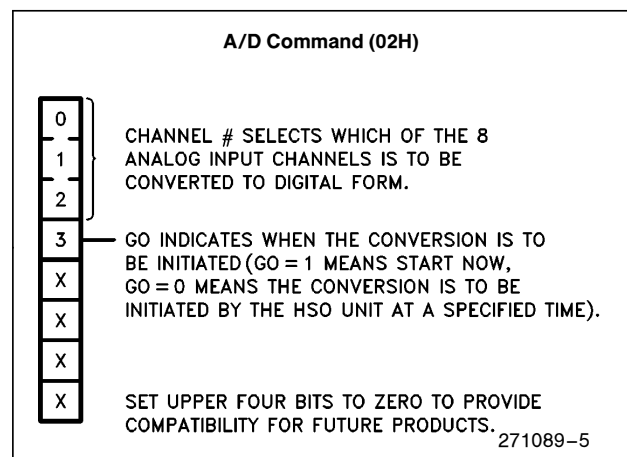
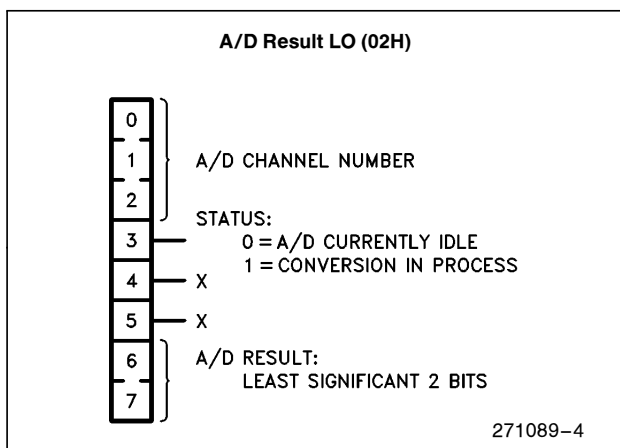

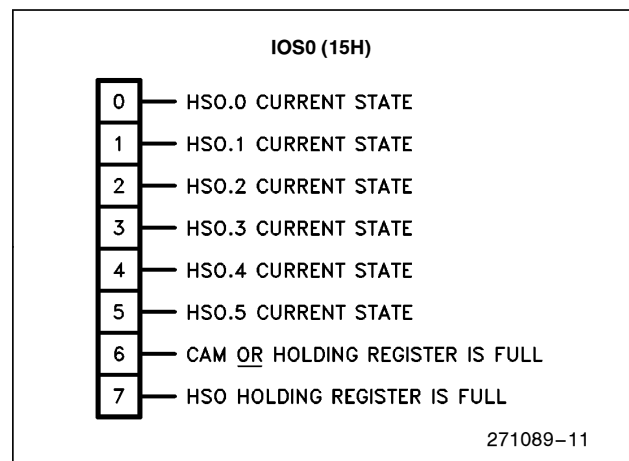
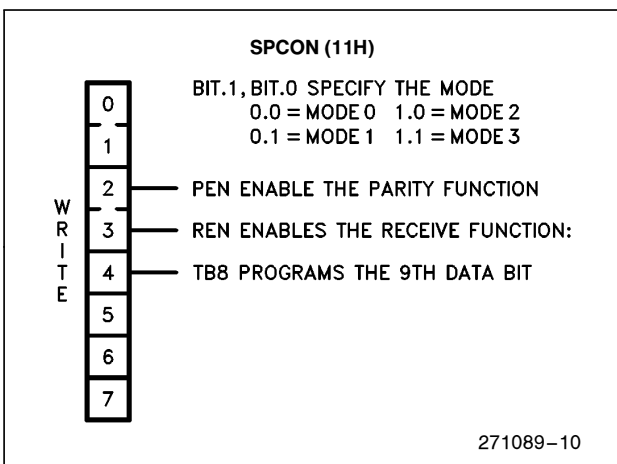
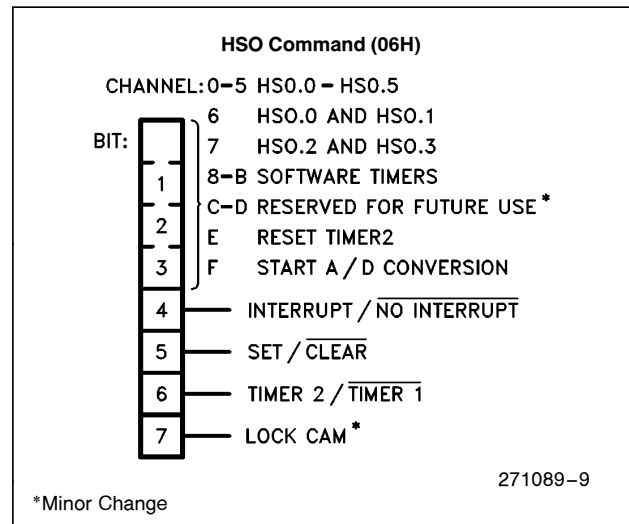
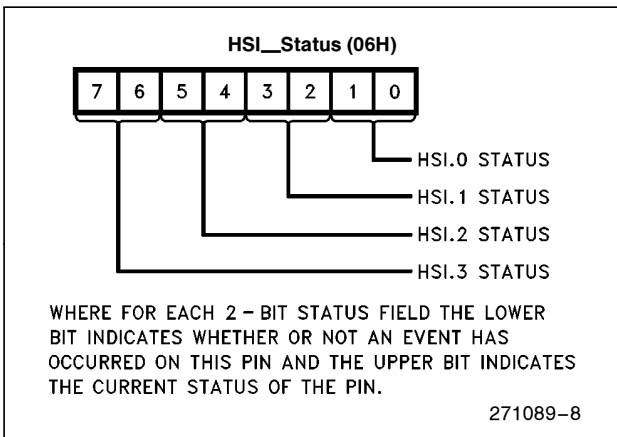
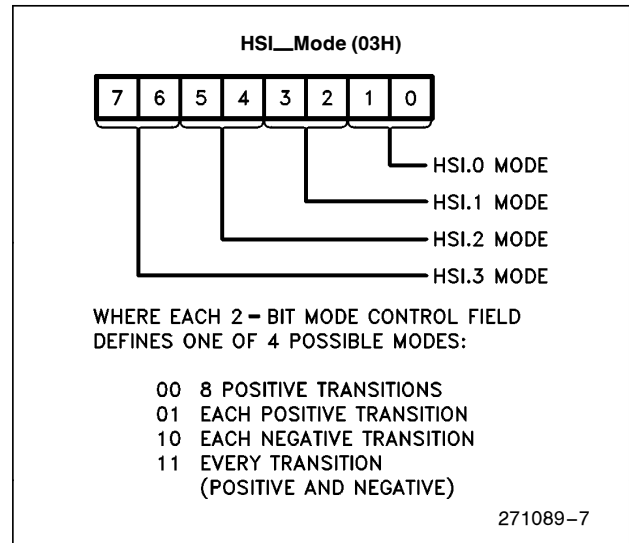
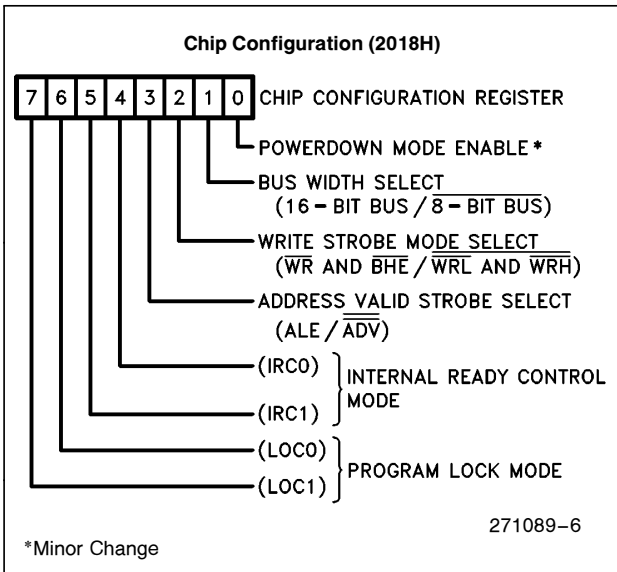

**IOC0 (15H)**

0	HSI.0 INPUT ENABLE / $\overline{\text{DISABLE}}$
1	TIMER 2 RESET EACH WRITE
2	HSI.1 INPUT ENABLE / $\overline{\text{DISABLE}}$
3	TIMER 2 EXTERNAL RESET ENABLE / $\overline{\text{DISABLE}}$
4	HSI.2 INPUT ENABLE / $\overline{\text{DISABLE}}$
5	TIMER 2 RESET SOURCE HSI.0 / $\overline{\text{T2RST}}$
6	HSI.3 INPUT ENABLE / $\overline{\text{DISABLE}}$
7	TIMER 2 CLOCK SOURCE HSI.1 / $\overline{\text{T2CLK}}$

271089-12

**IOS1 (16H)**

0	SOFTWARE TIMER 0 EXPIRED
1	SOFTWARE TIMER 1 EXPIRED
2	SOFTWARE TIMER 2 EXPIRED
3	SOFTWARE TIMER 3 EXPIRED
4	TIMER 2 HAS OVERFLOW
5	TIMER 1 HAS OVERFLOW
6	HSI FIFO IS FULL
7	HSI HOLDING REGISTER DATA AVAILABLE

271089-13

**IOC1 (16H)**

0	SELECT PWM / $\overline{\text{SELECT P2.5}}$
1	EXTERNAL INTERRUPT ACH7 / $\overline{\text{EXTINT}}$
2	TIMER 1 OVERFLOW INTERRUPT ENABLE / $\overline{\text{DISABLE}}$
3	TIMER 2 OVERFLOW INTERRUPT ENABLE / $\overline{\text{DISABLE}}$
4	HSO.4 OUTPUT ENABLE / $\overline{\text{DISABLE}}$
5	SELECT TXD / $\overline{\text{SELECT P2.0}}$
6	HSO.5 OUTPUT ENABLE / $\overline{\text{DISABLE}}$
7	HSI INTERRUPT FIFO FULL / $\overline{\text{HOLDING REGISTER LOADED}}$

271089-14

**Port 2 Multiple Functions**

Pin	Func.	Alternative Function	Control Reg.
2.0	Output	TXD (Serial Port Transmit)	IOC1.5
2.1	Input	RXD (Serial Port Receive)	SPCON.3
2.3	Input	T2CLK (Timer2 Clock & Baud)	IOC0.7
2.4	Input	T2RST (Timer2 Reset)	IOC0.5
2.5	Output	PWM Output	IOC1.0
2.6	QBD*	Timer2 up/down select	IOC2.1
2.7	QBD*	Timer2 Capture	N/A

\*QBD = Quasi-bidirectional

**Baud Rate Calculations**

**Asynchronous Modes 1, 2 and 3:**

$$\text{Baud\_Reg} = \frac{\text{XTAL1}}{\text{Baud Rate} \times 16} - 1 \text{ OR } \frac{\text{T2CLK}}{\text{Baud Rate} \times 8}$$

**Synchronous Mode 0:**

$$\text{Baud\_Reg} = \frac{\text{XTAL1}}{\text{Baud Rate} \times 2} - 1 \text{ OR } \frac{\text{T2CLK}}{\text{Baud Rate}}$$

**Baud Rates and Baud Register Values**

Baud Rate	XTAL Frequency					
	8.0 MHz		10.0 MHz		12.0 MHz	
300	1666	-0.02	2082	0.02	2499	0.00
1200	416	-0.08	520	-0.03	624	0.00
2400	207	0.16	259	0.16	312	-0.16
4800	103	-0.16	129	0.16	155	0.16
9600	51	-0.16	64	0.16	77	0.16
19.2K	25	0.16	32	1.40	38	0.16

**Baud Register Value/% Error**

A maximum baud rate of 750 Kbaud is available in the asynchronous modes with 12 MHz on XTAL1. The synchronous mode has a maximum rate of 3.0 Mbaud with a 12 MHz clock. Location 0EH is the Baud Register. It is loaded sequentially in two bytes, with the low byte being loaded first. This register may not be loaded with zero in serial port Mode 0.

**NOTE:**

The maximum T2CLK rate is 3 MHz when used to set the baud rate.

## ELECTRICAL CHARACTERISTICS

### Absolute Maximum Ratings\*

Case Temperature	
under Bias . . . . .	–55°C to +125°C
Storage Temperature . . . . .	–65°C to +150°C
Voltage On Any Pin to $V_{SS}$ . . . . .	–0.5V to +7.0V
Power Dissipation . . . . .	1.5W

NOTICE: This data sheet contains preliminary information on new products in production. The specifications are subject to change without notice. Verify with your local Intel Sales office that you have the latest data sheet before finalizing a design.

*\*WARNING: Stressing the device beyond the “Absolute Maximum Ratings” may cause permanent damage. These are stress ratings only. Operation beyond the “Operating Conditions” is not recommended and extended exposure beyond the “Operating Conditions” may affect device reliability.*

## OPERATING CONDITIONS

### MIL-STD-883

Symbol	Description	Min	Max	Units
$T_C$	Case Temperature (Instant On)	–55	+125	°C
$V_{CC}$	Digital Supply Voltage	4.50	5.50	V
$V_{REF}$	Analog Supply Voltage	4.50	5.50	V
$f_{OSC}$	Oscillator Frequency	3.5	12	MHz

### Military Temperature (MTO)

Symbol	Description	Min	Max	Units
$T_C$	Case Temperature (Instant On)	–55	+125	°C
$V_{CC}$	Digital Supply Voltage	4.50	5.50	V
$V_{REF}$	Analog Supply Voltage	4.50	5.50	V
$f_{OSC}$	Oscillator Frequency	3.5	12	MHz

**NOTE:**  
ANGND and  $V_{SS}$  should be nominally at the same potential.

### DC Characteristics (Over Specified Operating Conditions)

Symbol	Description	Min	Max	Units	Comments
$V_{IL}$	Input Low Voltage	–0.5	0.8	V	
$V_{IH}$	Input High Voltage (Note 1)	$0.2 V_{CC} + 1.0$	$V_{CC}$	V	
$V_{IH1}$	Input High Voltage on XTAL 1	$0.7 V_{CC}$	$V_{CC}$	V	
$V_{IH2}$	Input High Voltage on $\overline{RESET}$	2.2	$V_{CC}$	V	
$V_{OL}$	Output Low Voltage		0.3 0.45 1.5	V V V	$I_{OL} = 200 \mu A$ $I_{OL} = 3.2 mA$ $I_{OL} = 7 mA$
$V_{OH}$	Output High Voltage (Standard Outputs) (Note 2)	$V_{CC} - 0.3$ $V_{CC} - 0.7$ $V_{CC} - 1.5$		V V V	$I_{OH} = -200 \mu A$ $I_{OH} = -3.2 mA$ $I_{OH} = -7 mA$
$V_{OH1}$	Output High Voltage (Quasi-bidirectional Outputs) (Note 3)	$V_{CC} - 0.3$ $V_{CC} - 0.7$ $V_{CC} - 1.5$		V V V	$I_{OH} = -10 \mu A$ $I_{OH} = -30 \mu A$ $I_{OH} = -60 \mu A$

**NOTES:**  
 1. All pins except  $\overline{RESET}$  and XTAL1.  
 2. Standard Outputs include AD0–15,  $\overline{RD}$ ,  $\overline{WR}$ , ALE,  $\overline{BHE}$ , INST, HSO pins, PWM/P2.5, CLKOUT, RESET, Ports 3 and 4, TXD/P2.0, and RXD (in serial mode 0). The  $V_{OH}$  specification is not valid for RESET. Ports 3 and 4 are open-drain outputs.  
 3. QBD (Quasi-bidirectional) pins include Port 1, P2.6 and P2.7.

**DC Characteristics** (Over Specified Operating Conditions) (Continued)

Symbol	Description	Min	Max	Units	Comments
$I_{LI}$	Input Leakage Current (Std. Inputs) (Note 4)		$\pm 10$	$\mu A$	$0 < V_{IN} < V_{CC} - 0.3V$
$I_{LI1}$	Input Leakage Current ()		$\pm 7$	mA	$0 < V_{IN} < V_{REF}$
$I_{TL}$	1 to 0 Transition Current (QBD Pins) (Note 3)		-800	$\mu A$	$V_{IN} = 2.0V$
$I_{IL}$	Logical 0 Input Current (QBD Pins) (Note 3)		-50	$\mu A$	$V_{IN} = 0.45V$
$I_{IL1}$	Logical 0 Input Current in Reset (Note 5) (ALE, $\overline{RD}$ , $\overline{WR}$ , $\overline{BHE}$ , INST, P2.0)		-850	$\mu A$	$V_{IN} = 0.45 V$
$I_{CC}$	Active Mode Current in Reset		60	mA	XTAL1 = 12 MHz
$I_{REF}$	A/D Converter Reference Current		5	mA	$V_{CC} = V_{PP} = V_{REF} = 5.5V$
$I_{IDLE}$	Idle Mode Current		25	mA	
$I_{CC1}$	Active Mode Current		30	mA	XTAL1 = 3.5 MHz
$I_{PD}$	Powerdown Mode Current		50	$\mu A$	$V_{CC} = V_{PP} = V_{REF} = 5.5V$ , XTAL1 = 12 MHz
$R_{RST}$	Reset Pullup Resistor	6K	50K	$\Omega$	
$C_S$	Pin Capacitance (Any Pin to $V_{SS}$ )		10	pF	$f_{TEST} = 1.0 \text{ MHz}$

**NOTES:**

(Notes apply to all specifications)

- Standard Outputs include AD0-15,  $\overline{RD}$ ,  $\overline{WR}$ , ALE,  $\overline{BHE}$ , INST, HSO pins, PWM/P2.5, CLKOUT, RESET, Ports 3 and 4, TXD/P2.0, and RXD (in serial mode 0). The  $V_{OH}$  specification is not valid for RESET. Ports 3 and 4 are open-drain outputs.
- QBD (Quasi-bidirectional) pins include Port 1, P2.6 and P2.7.
- Standard Inputs include HSI pins,  $\overline{EA}$ , READY, BUSWIDTH, NMI, RXD/P2.1, EXTINT/P2.2, T2CLK/P2.3, and T2RST/P2.4.
- Holding these pins below  $V_{IH}$  in Reset may cause the part to enter test modes.
- Maximum current per pin must be externally limited to the following values if  $V_{OL}$  is held above 0.45V or  $V_{OH}$  is held below  $V_{CC} - 0.7V$ :
  - $I_{OL}$  on Output pins: 10 mA
  - $I_{OH}$  on quasi-bidirectional pins: self limiting
  - $I_{OH}$  on Standard Output pins: 10 mA
- Maximum current per bus pin (data and control) during normal operation is  $\pm 3.2$  mA.
- During normal (non-transient) conditions the following total current limits apply:
 

Port 1, P2.6	$I_{OL}$ : 29 mA	$I_{OH}$ is self limiting
HSO, P2.0, RXD, $\overline{RESET}$	$I_{OL}$ : 29 mA	$I_{OH}$ : 26 mA
P2.5, P2.7, $\overline{WR}$ , $\overline{BHE}$	$I_{OL}$ : 13 mA	$I_{OH}$ : 11 mA
AD0-AD15	$I_{OL}$ : 52 mA	$I_{OH}$ : 52 mA
$\overline{RD}$ , ALE, INST-CLKOUT	$I_{OL}$ : 13 mA	$I_{OH}$ : 13 mA

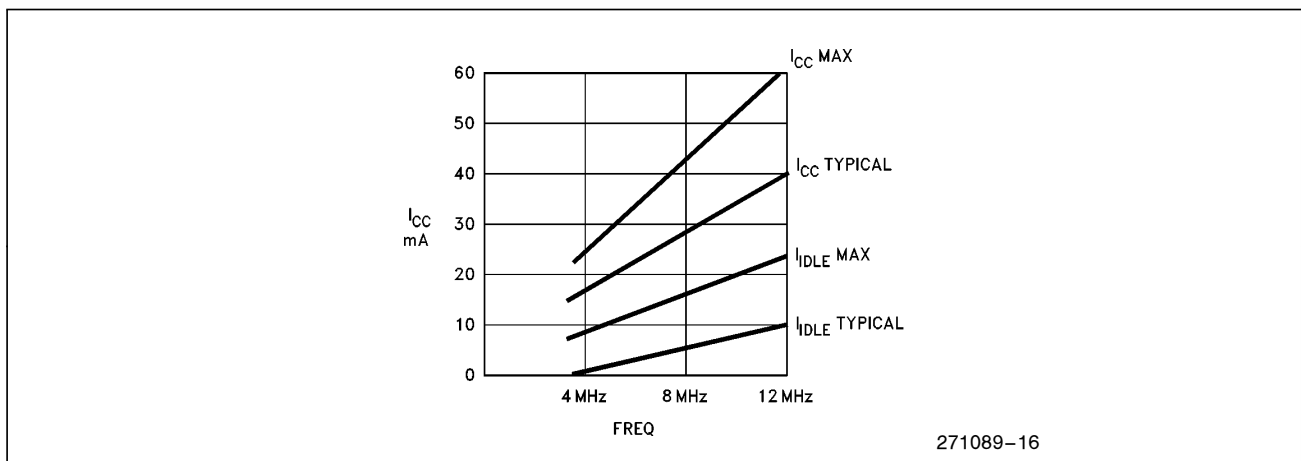

**Figure 4.  $I_{CC}$  and  $I_{IDLE}$  vs Frequency**

**AC Characteristics** (Over Specified Operating Conditions)

 Test Conditions: Capacitive load on all pins = 100 pF, Rise and fall times = 10 ns,  $f_{OSC} = 12$  MHz

**The system must meet these specifications to work with the M80C196KB:**

Symbol	Description	Min	Max	Units	Notes
$T_{AVYV}$	Address Valid to READY Setup		$2T_{OSC} - 85$	ns	
$T_{LLYV}$	ALE Low to READY Setup M80C196KB		$T_{OSC} - 75$	ns	
$T_{YLYH}$	Non READY Time	No upper limit		ns	
$T_{CLYX}$	READY Hold after CLKOUT Low	0	$T_{OSC} - 30$	ns	(Note 1)
$T_{LLYX}$	READY Hold after ALE Low	$T_{OSC} - 15$	$2T_{OSC} - 40$	ns	(Note 1)
$T_{AVGV}$	Address Valid to Buswidth Setup		$2T_{OSC} - 85$	ns	
$T_{LLGV}$	ALE Low to Buswidth Setup		$T_{OSC} - 70$	ns	
$T_{CLGX}$	Buswidth Hold after CLKOUT Low	0		ns	
$T_{AVDV}$	Address Valid to Input Data Valid M80C196KB		$3T_{OSC} - 67$	ns	
$T_{RLDV}$	$\overline{RD}$ Active to Input Data Valid M80C196KB		$T_{OSC} - 23$	ns	
$T_{CLDV}$	CLKOUT Low to Input Data Valid		$T_{OSC} - 50$	ns	
$T_{RHDZ}$	End of $\overline{RD}$ to Input Data Float		$T_{OSC} - 20$	ns	
$T_{RXDX}$	Data Hold after $\overline{RD}$ Inactive	0		ns	

**NOTE:**

1. If max is exceeded, additional wait states will occur.

**AC Characteristics** (Over Specified Operating Conditions) (Continued)Test Conditions: Capacitive load on all pins = 100 pF, Rise and fall times = 10 ns,  $f_{OSC}$  = 12 MHz**The M80C196KB will meet these specifications:**

Symbol	Description	Min	Max	Units	Notes
$F_{XTAL}$	Frequency on XTAL <sub>1</sub> M80C196KB	3.5	12	MHz	
$T_{OSC}$	$1/F_{XTAL}$ M80C196KB	83	286	ns	
$T_{XHCH}$	XTAL1 High to CLKOUT High or Low	20	110	ns	
$T_{CLCL}$	CLKOUT Cycle Time	$2T_{OSC}$		ns	
$T_{CHCL}$	CLKOUT High Period	$T_{OSC} - 10$	$T_{OSC} + 10$	ns	
$T_{CLLH}$	CLKOUT Falling Edge to ALE Rising	-10	10	ns	
$T_{LLCH}$	ALE Falling Edge to CLKOUT Rising	-15	15	ns	
$T_{LHLH}$	ALE Cycle Time	$4T_{OSC}$		ns	
$T_{LHLL}$	ALE High Period	$T_{OSC} - 12$	$T_{OSC} + 12$	ns	
$T_{AVLL}$	Address Setup to ALE Falling Edge	$T_{OSC} - 20$		ns	
$T_{LLAX}$	Address Hold after ALE Falling Edge	$T_{OSC} - 40$		ns	
$T_{LLRL}$	ALE Falling Edge to $\overline{RD}$ Falling Edge	$T_{OSC} - 40$		ns	
$T_{RLCL}$	$\overline{RD}$ Low to CLKOUT Falling Edge	4	25	ns	
$T_{RLRH}$	$\overline{RD}$ Low Period	$T_{OSC} - 5$		ns	
$T_{RHLLH}$	$\overline{RD}$ Rising Edge to ALE Rising Edge	$T_{OSC}$	$T_{OSC} + 25$	ns	(Note 2)
$T_{RLAZ}$	$\overline{RD}$ Low to Address Float		10	ns	
$T_{LLWL}$	ALE Falling Edge to $\overline{WR}$ Falling Edge	$T_{OSC} - 10$		ns	
$T_{CLWL}$	CLKOUT Low to $\overline{WR}$ Falling Edge	0	25	ns	
$T_{QVWH}$	Data Stable to $\overline{WR}$ Rising Edge M80C196KB	$T_{OSC} - 23$		ns	
$T_{CHWH}$	CLKOUT High to $\overline{WR}$ Rising Edge	-5	15	ns	
$T_{WLWH}$	$\overline{WR}$ Low Period	$T_{OSC} - 30$		ns	
$T_{WHQX}$	Data Hold after $\overline{WR}$ Rising Edge	$T_{OSC} - 15$		ns	
$T_{WHLH}$	$\overline{WR}$ Rising Edge to ALE Rising Edge	$T_{OSC} - 15$	$T_{OSC} + 10$	ns	(Note 2)
$T_{WHBX}$	$\overline{BHE}$ , INST HOLD after $\overline{WR}$ Rising Edge	$T_{OSC} - 15$		ns	

**NOTE:**

2. Assuming back-to-back bus cycles.



System Bus Timings

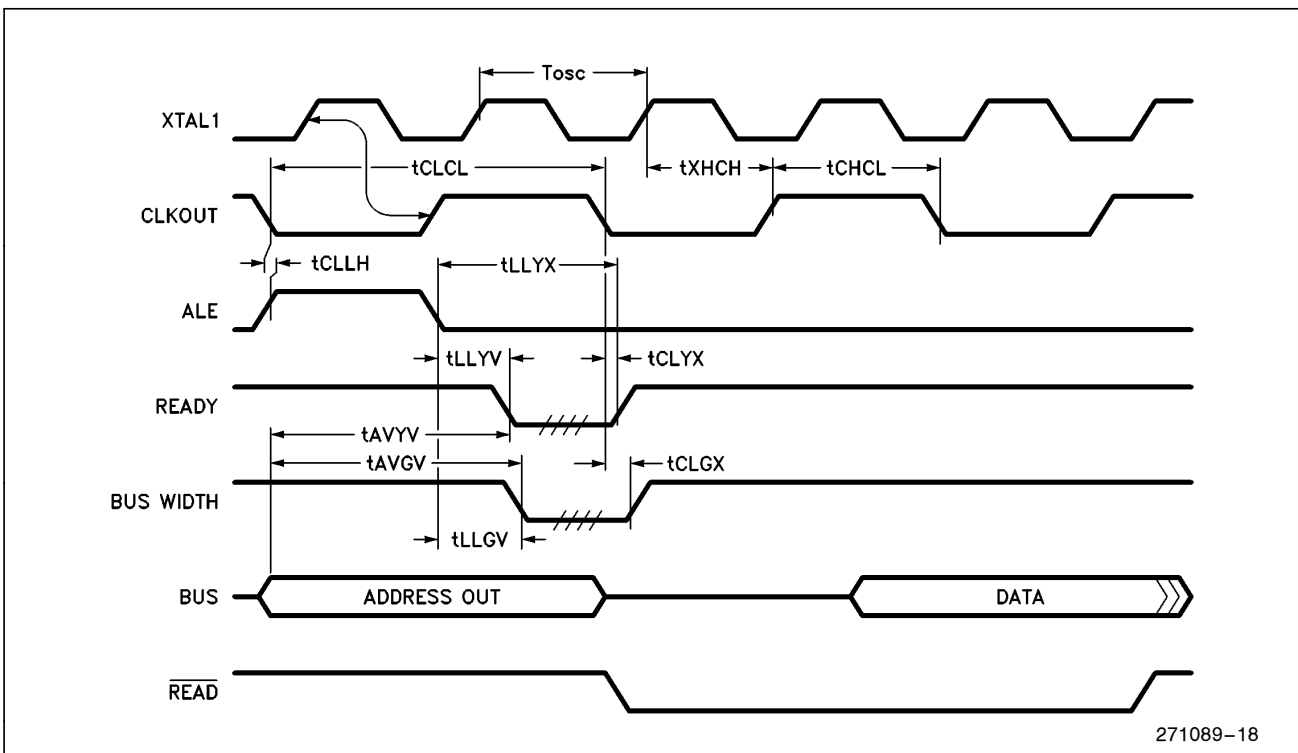
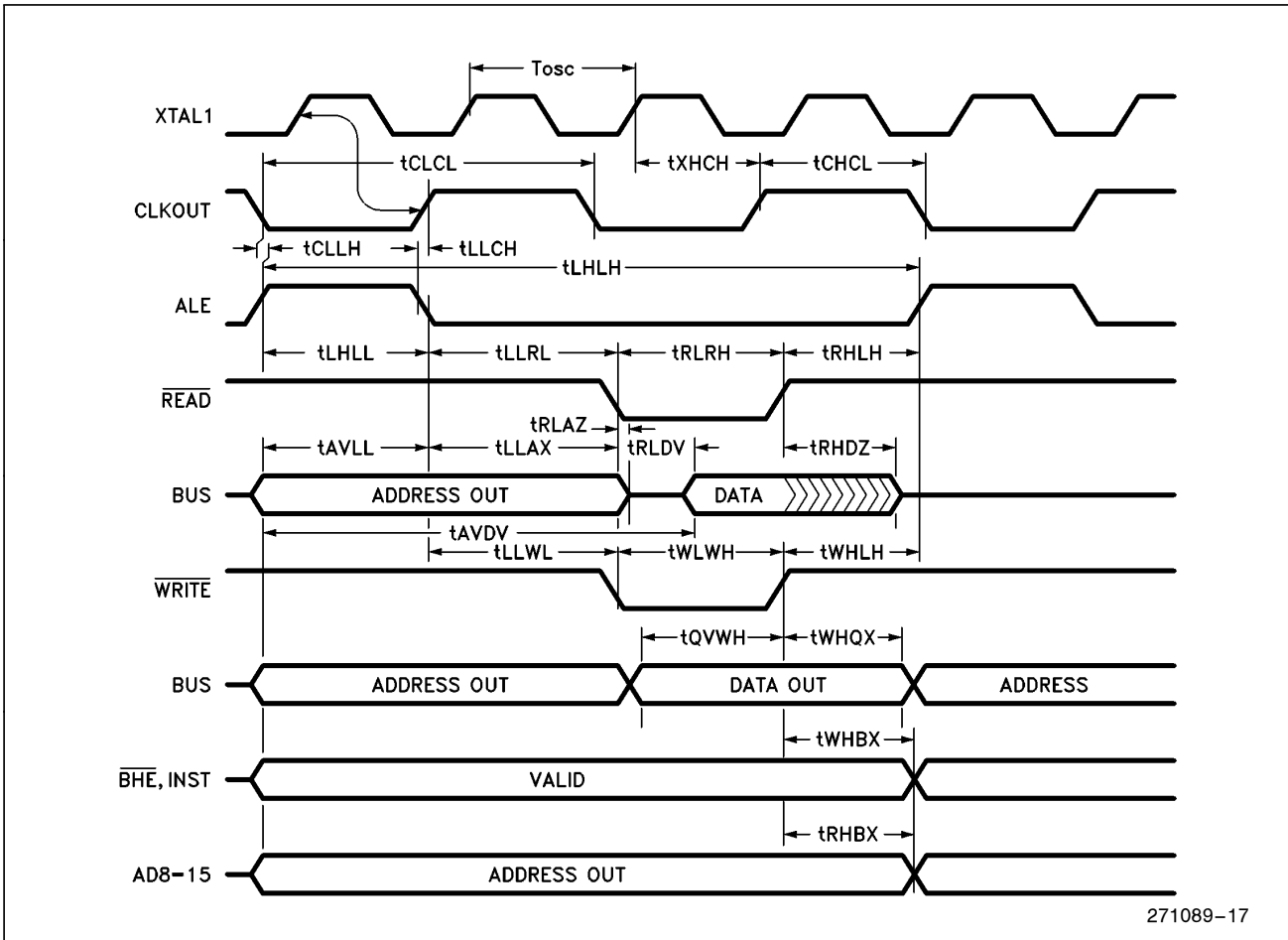

**EXTERNAL CLOCK DRIVE**

Symbol	Parameter	Min	Max	Units
$1/T_{XLXL}$	Oscillator Frequency M80C196KB	3.5	12.0	MHz
$T_{XLXL}$	Oscillator Period M80C196KB	83	286	ns
$T_{XHXX}$	High Time	32		ns
$T_{XLXX}$	Low Time	32		ns
$T_{XLXH}$	Rise Time		10	ns
$T_{XHXL}$	Fall Time		10	ns

**EXTERNAL CLOCK DRIVE WAVEFORMS**

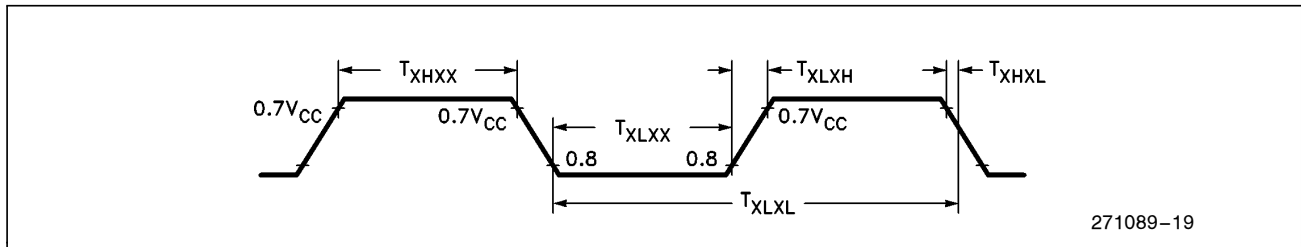

**AC TESTING INPUT, OUTPUT WAVEFORMS**

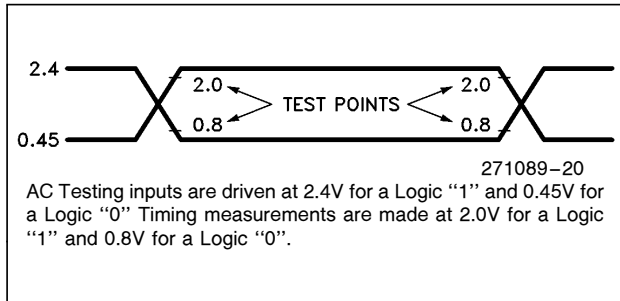

**FLOAT WAVEFORMS**

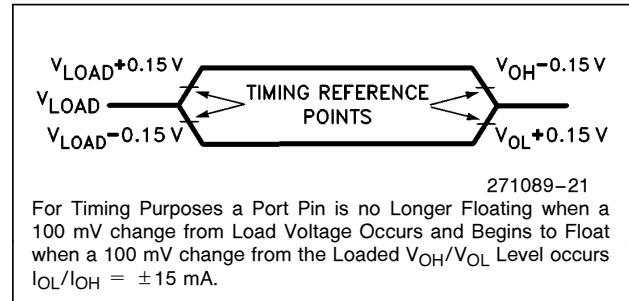

**EXPLANATION OF AC SYMBOLS**

Each symbol is two pairs of letters prefixed by "T" for time. The characters in a pair indicate a signal and its condition, respectively. Symbols represent the time between the two signal/condition points.

**Conditions:**

- H - High
- L - Low
- V - Valid
- X - No Longer Valid
- Z - Floating

**Signals:**

- A - Address
- B -  $\overline{BHE}$
- C - CLKOUT
- D - DATA
- G - Buswidth

- L -  $ALE/\overline{ADV}$
- R -  $\overline{RD}$
- W -  $\overline{WR}/\overline{WRH}/\overline{WRL}$
- X - XTAL1
- Y - READY



## A TO D CHARACTERISTICS

There are two modes of A/D operation: with or without clock prescaler. The speed of the A/D converter can be adjusted by setting a clock prescaler on or off. At high frequencies more time is needed for the comparator to settle. The maximum frequency with the clock prescaler disabled is 8 MHz. The conversion times with the prescaler turned on or off is shown in the table below.

The converter is ratiometric, so the absolute accuracy is directly dependent on the accuracy and

stability of  $V_{REF}$ .  $V_{REF}$  must be close to  $V_{CC}$  since it supplies both the resistor ladder and the digital section of the converter.

## A/D CONVERTER SPECIFICATIONS

The specifications given below assume adherence to the Operating Conditions section of this data sheet. Testing is performed in Mode 2 with  $V_{REF} = 5.12V$  and 12 MHz on XTAL1.

Clock Prescaler On IOC2.4 = 0	Clock Prescaler Off IOC2.4 = 1
Mode 0–158 States 26.33 $\mu s$ @ 12 MHz	Mode 2–91 States 22.75 $\mu s$ @ 8 MHz

## A/D CHARACTERISTICS (Over Specified Operating Conditions)

Parameter	Typical*(1)	Minimum	Maximum	Units**	Notes
Resolution		256	1024 10	Levels Bits	
Absolute Error		0	$\pm 4$	LSBs	
Full Scale Error	$-0.5 \pm 0.5$			LSBs	
Zero Offset Error	$\pm 0.5$			LSBs	
Non-Linearity		0	$\pm 4$	LSBs	
Differential Non-Linearity		0	$\pm 2$	LSBs	
Channel-to-Channel Matching		0	$\pm 1$	LSBs	
Repeatability	$\pm 0.25$			LSBs	
Temperature Coefficients: Offset Full Scale Differential Non-Linearity	0.009 0.009 0.009			LSB/°C LSB/°C LSB/°C	
Off Isolation		-60		dB	2, 3
Feedthrough	-60			dB	2
$V_{CC}$ Power Supply Rejection	-60			dB	2
Input Resistance		750	1.2K	$\Omega$	
DC Input Leakage		0	3.0	$\mu A$	
Sample Time Slow Mode Fast Mode	15 8			States States	4 4
Input Capacitance	3			pF	

### NOTES:

\*An "LSB", as used here, has a value of approximately 5 mV.

1. These values are expected for most parts at 25°C but are not tested or guaranteed.
2. DC to 100 KHz.
3. Multiplexer Break-Before-Make Guaranteed.
4. One state = 167 ns at 12 MHz, 250 ns at 8 MHz.

## A/D GLOSSARY OF TERMS

**ABSOLUTE ERROR**—The maximum difference between corresponding actual and ideal code transitions. Absolute Error accounts for all deviations of an actual converter from an ideal converter.

**ACTUAL CHARACTERISTIC**—The characteristic of an actual converter. The characteristic of a given converter may vary over temperature, supply voltage, and frequency conditions. An actual characteristic rarely has ideal first and last transition locations or ideal code widths. It may even vary over multiple conversions under the same conditions.

**BREAK-BEFORE-MAKE**—The property of multiplexer which guarantees that a previously selected channel will be deselected before a new channel is selected (e.g., the converter will not short inputs together).

**CHANNEL-TO-CHANNEL MATCHING**—The difference between corresponding code transitions of actual characteristics taken from different channels under the same temperature, voltage and frequency conditions.

**CHARACTERISTIC**—A graph of input voltage versus the resultant output code for an A/D converter. It describes the transfer function of the A/D converter.

**CODE**—The digital value output by the converter.

**CODE TRANSITION**—The point at which the converter changes from an output code of  $Q$ , to a code of  $Q + 1$ . The input voltage corresponding to a code transition is defined to be that voltage which is equally likely to produce either of two adjacent codes.

**CODE WIDTH**—The voltage corresponding to the difference between two adjacent code transitions.

**DC INPUT LEAKAGE**—Leakage current to ground from an analog input pin.

**DIFFERENTIAL NON-LINEARITY**—The difference between the ideal and actual code widths of the terminal based characteristic.

**FEEDTHROUGH**—Attenuation of a voltage applied on the selected channel of the A/D Converter after the sample window closes.

**FULL SCALE ERROR**—The difference between the expected and actual input voltage corresponding to the full scale code transition.

**IDEAL CHARACTERISTIC**—A characteristic with its first code transition at  $V_{IN} = 0.5 \text{ LSB}$ , its last code transition at  $V_{IN} = (V_{REF} - 1.5 \text{ LSB})$  and all code widths equal to one LSB.

**INPUT RESISTANCE**—The effective series resistance from the analog input pin to the sample capacitor.

**LSB—Least Significant Bit:** The voltage corresponding to the full scale voltage divided by  $2^n$ , where  $n$  is the number of bits of resolution of the converter. For an 8-bit converter with a reference voltage of 5.12V, one LSB is 20 mV. Note that this is different than digital LSBs, since an uncertainty of two LSB, when referring to an A/D converter, equals 40 mV. (This has been confused with an uncertainty of two digital bits, which would mean four counts, or 80 mV.)

**NON-LINEARITY**—The maximum deviation of code transitions of the terminal based characteristic from the corresponding code transitions of the ideal characteristic.

**OFF-ISOLATION**—Attenuation of a voltage applied on a deselected channel of the A/D converter. (Also referred to as Crosstalk.)

**REPEATABILITY**—The difference between corresponding code transitions from different actual characteristics taken from the same converter on the same channel at the same temperature, voltage and frequency conditions.

**RESOLUTION**—The number of input voltage levels that the converter can unambiguously distinguish between. Also defines the number of useful bits of information which the converter can return.

**SAMPLE TIME**—Begins when the sample capacitor is attached to a selected channel and ends when the sample capacitor is disconnected from the selected channel.

**TEMPERATURE COEFFICIENTS**—Change in the stated variable per degree centigrade temperature change. Temperature coefficients are added to the typical values of a specification to see the effect of temperature drift.

**TERMINAL BASED CHARACTERISTIC**—An actual characteristic which has been rotated and translated to remove zero offset and full scale error.

**V<sub>CC</sub> REJECTION**—Attenuation of noise on the  $V_{CC}$  line to the A/D converter.

**ZERO OFFSET**—The difference between the expected and actual input voltage corresponding to the first code transition.

## M80C196KB FUNCTIONAL DEVIATIONS

The M80C196KB has the following problems.

1. The DJNZW instruction is guaranteed to be functional. The DJNZ (byte instruction) work around is no longer needed.
2. The serial port only tolerates a +1.25%, -7.5% baud rate error between Transmitter and Receiver. If the serial port fails on the receiver, increase the baud rate.
3. The HSI unit has two errata: one dealing with resolution and the other with first entries into the FIFO.

The HSI resolution is 9 states instead of 8 states. Events on the same line may be lost if they occur faster than once every 9 state times.

There is a mismatch between the 9 state time HSI resolution and the 8 state time timer. This causes one time value to be unused every 9 timer counts. Events may receive a time-tag one count later than expected because of this "skipped" time value.

If the first two events into an empty FIFO (not including the Holding Register) occur in the same internal phase, both are recorded with one time-tag. Otherwise, if the second event occurs within 9 states after the first, its time-tag is one count later than the first's. If this is the "skipped" time value, the second event's time-tag is 2 counts later than the first's.

If the FIFO and Holding Register are empty, the first event will transfer into the Holding Register after 8 state times, leaving the FIFO empty again. If the second event occurs after this time, it will act as a new first event into an empty FIFO.

4. The serial port Framing Error flag that failed to indicate an error if the bit preceding the stop bit is a 1 has been fixed.

## CONVERTING FROM OTHER M8097 FAMILY PRODUCTS TO THE M80C196KB

The following list of suggestions for designing an M809XBH system will yield a design that is easily converted to the M80C196KB.

1. Do not base critical timing loops on instruction or peripheral execution times.
2. Use equate statements to set all timing parameters, including the baud rate.
3. Do not base hardware timings on CLKOUT or XTAL1. The timings of the M80C196KB are different than those of the M8X9XBH, but they will function with standard ROM/EPROM/Peripheral type memory systems.
4. Make sure all inputs are tied high or low and not left floating.
5. Indexed and indirect operations relative to the stack pointer (SP) work differently on the M80C196KB than on the M8097. On the M8097, the address is calculated based on the un-updated version of the stack pointer. The M80C196KB uses the updated version. The offset for PUSH[SP], POP[SP], PUSH nn[SP] and POP nn[SP] instructions may need to be changed by a count of 2.