



DD28F032SA 32-MBIT (2 MBIT X 16, 4 MBIT X 8) FlashFile™ MEMORY

- User-Selectable 3.3V or 5V V_{CC}
- User-Configurable x8 or x16 Operation
- 70 ns Maximum Access Time
- 28.6 MB/sec Burst Write Transfer Rate
- 1 Million Typical Erase Cycles per Block
- 56-Lead, 1.2 x 14 x 20 mm Advanced Dual Die TSOP Package Technology
- 64 Independently Lockable Blocks
- Revolutionary Architecture
 - 100% Backwards-Compatible with Intel 28F016SA
 - Pipelined Command Execution
 - Program during Erase
- 2 mA Typical I_{CC} in Static Mode
- 2 µA Typical Deep Power-Down
- State-of-the-Art 0.6 µm ETOX™ IV Flash Technology

Intel's DD28F032SA 32-Mbit FlashFile™ memory is a revolutionary architecture which enables the design of truly mobile, high performance, personal computing and communication products. With innovative capabilities, low power operation and very high read/program performance, the DD28F032SA is also the ideal choice for designing embedded mass storage flash memory systems.

The DD28F032SA is the result of highly-advanced packaging innovation which encapsulates two 28F016SA die in a single Dual Die Thin Small Outline Package (DDTSOP).

The DD28F032SA is the highest density, highest performance nonvolatile read/program solution for solid-state storage applications. Its symmetrically-blocked architecture (100% compatible with the 28F016SA 16-Mbit FlashFile memory), very high-cycling, low-power 3.3V operation, very fast program and read performance and selective block locking provide a highly flexible memory component suitable for high-density memory cards, Resident Flash Arrays and PCMCIA-ATA Flash Drives. The DD28F032SA's dual read voltage enables the design of memory cards which can be read/written in 3.3V and 5.0V systems interchangeably. Its x8/x16 architecture allows the optimization of memory to processor interface. The flexible block locking option enables bundling of executable application software in a Resident Flash Array or memory card. The DD28F032SA will be manufactured on Intel's 0.6 µm ETOX IV technology.

Information in this document is provided in connection with Intel products. No license, express or implied, by estoppel or otherwise, to any intellectual property rights is granted by this document. Except as provided in Intel's Terms and Conditions of Sale for such products, Intel assumes no liability whatsoever, and Intel disclaims any express or implied warranty, relating to sale and/or use of Intel products including liability or warranties relating to fitness for a particular purpose, merchantability, or infringement of any patent, copyright or other intellectual property right. Intel products are not intended for use in medical, life saving, or life sustaining applications.

Intel may make changes to specifications and product descriptions at any time, without notice.

The 28F016SA may contain design defects or errors known as errata. Current characterized errata are available upon request.

*Third-party brands and names are the property of their respective owners.

Contact your local Intel sales office or your distributor to obtain the latest specifications and before placing your product order.

Copies of documents which have an ordering number and are referenced in this document, or other Intel literature, may be obtained from:

Intel Corporation
P.O. Box 7641
Mt. Prospect, IL 60056-7641

or call 1-800-879-4683

COPYRIGHT © INTEL CORPORATION, 1996

CG-041493

CONTENTS

PAGE	PAGE
1.0 PRODUCT OVERVIEW.....	5
2.0 DEVICE PINOUT.....	6
2.1 Lead Descriptions	8
3.0 MODES OF OPERATION	10
4.0 MEMORY MAPS	11
4.1 Extended Status Registers Memory Map...	12
5.0 BUS OPERATIONS, COMMANDS AND STATUS REGISTER DEFINITIONS.....	13
5.1 Bus Operations for Word-Wide Mode (BYTE# = V _{IH})	13
5.2 Bus Operations for Byte-Wide Mode (BYTE# = V _{IL})	13
5.3 28F008SA Compatible Mode Command Bus Definitions	14
5.4 28F016SA-Performance Enhancement Command Bus Definitions.....	15
5.5 Compatible Status Register	16
5.6 Global Status Register	17
5.7 Block Status Register	18
6.0 ELECTRICAL SPECIFICATIONS.....	19
6.1 Absolute Maximum Ratings.....	19
6.2 Capacitance	20
6.3 Timing Nomenclature	21
6.4 DC Characteristics (V _{CC} = 3.3V ± 0.3V)	24
6.5 DC Characteristics (V _{CC} = 5.0V ± 0.5V)	26
6.6 AC Characteristics—Read Only Operations	28
6.7 Power-Up and Reset Timings.....	32
6.8 AC Characteristics for WE#—Controlled Command Write Operations	33
6.9 AC Characteristics for CE _x #—Controlled Write Operations	37
6.10 AC Characteristics for Page Buffer Write Operations	41
6.11 Erase and Word/Byte Program Performance, Cycling Performance and Suspend Latency	44
7.0 DERATING CURVES	45
8.0 MECHANICAL SPECIFICATIONS	47
APPENDIX A: Device Nomenclature/ Ordering Information	48
APPENDIX B: Additional Information.....	49



REVISION HISTORY

Number	Description
-001	—Original Version
-002	—Never Published
-003	—Full Datasheet with Specifications —CE ₀ #, CE ₁ # control 28F016SA No. 1 —CE ₀ #, CE ₂ # control 28F016SA No. 2
-004	—DC Characteristics (3.3V V _{CC}): I _{CCR} ¹ (TTL): BYTE# = V _{IL} or V _{IH} —Full Chip Erase Time (3.3V V _{CC}) = 51.2 sec typ —Full Chip Erase Time (5.0V V _{CC}) = 38.4 sec typ —Section 6.7: Added specifications t _{PHEL3} , t _{PHEL5} —TSOP dimension A ₁ = 0.05 mm (min) —Revised Product Status to Preliminary —t _{WHGL} (3.3V) = 120 ns —Minor cosmetic changes
-005	—Updated AC/DC parameters



1.0 PRODUCT OVERVIEW

The DD28F032SA is a high-performance 32-Mbit (33,554,432-bit) block erasable nonvolatile random access memory organized as either 2 Mword x 16, or 4 Mbyte x 8. The DD28F032SA is built using two 28F016SA chips encapsulated in a single 56-lead TSOP Type I package. The DD28F032SA includes sixty-four 64-KB (65,536) blocks or sixty-four 32-KW (32,768) blocks.

The DD28F032SA architecture allows operations to be performed on a single, 16-Mbit chip at a time.

The implementation of a new architecture, with many enhanced features, will improve the device operating characteristics and results in greater product reliability and ease of use.

Among the significant enhancements on the DD28F032SA:

- 3.3V Low Power Capability
- Improved Program Performance
- Dedicated Block Program/Erase Protection

A 3/5# input pin reconfigures the device internally for optimized 3.3V or 5.0V read/program operation.

The DD28F032SA will be available in a 56-lead, 1.2 mm thick, 14 mm x 20 mm Dual Die TSOP Type I package. This form factor and pinout allow for very high board layout densities. The DD28F032SA is pinout and footprint compatible with the 28F016SA.

Two Command User Interfaces (CUI) serve as the system interface between the microprocessor or microcontroller and the internal memory operation.

Internal algorithm automation allows word/byte programs and block erase operations to be executed using a two-write command sequence to the CUI in the same way as the 28F016SA 16-Mbit FlashFile memory.

A super-set of commands has been added to the basic 28F008SA (8-Mbit FlashFile memory) command-set to achieve higher program performance and provide additional capabilities.

These new commands and features include:

- Page Buffer Writes to Flash
- Command Queueing Capability
- Automatic Data Programs during Erase
- Software Locking of Memory Blocks
- Two-Byte Successive Programs in 8-bit Systems
- Erase All Unlocked Blocks

These operations can only be performed on one 16-Mbit device at a time. If the WSM is busy performing an operation, the system should not attempt to select the other device.

Writing of memory data is performed in either byte or word increments typically within 6 μ s, a 33% improvement over the 28F008SA. A block erase operation erases one of the 64 blocks in typically 0.6 sec, independent of the other blocks, which is a 65% improvement over the 28F008SA.

Each block can be written and erased a minimum of 100,000 cycles. Systems can achieve typically 1 million block erase cycles by providing wear-leveling algorithms and graceful block retirement. These techniques have already been employed in many flash file systems. Additionally, wear leveling of block erase cycles can be used to minimize the program/erase performance differences across blocks.

The DD28F032SA incorporates two Page Buffers of 256 bytes (128 words) on each 28F016SA to allow page data programs. This feature can improve a system program performance by up to 4.8 times over previous flash memory devices.

All operations are started by a sequence of command writes to the device. Three Status Registers (described in detail later) and a RY/BY# output pin provide information on the progress of the requested operation.

The DD28F032SA allows queueing of the next operation while the memory executes the current operation. This eliminates system overhead when writing several bytes in a row to the array or erasing several blocks at the same time. The DD28F032SA can also perform program operations to one block of memory while performing erase of another block. However, simultaneous program and/or erase operations are not allowed on both 28F016SA devices. See Modes of Operation, Section 3.0.

The DD28F032SA provides user-selectable block locking to protect code or data such as device drivers, PCMCIA card information, ROM-executable O/S or application code. Each block has an associated nonvolatile lock-bit which determines the lock status of the block. In addition, the DD28F032SA has a master Write Protect pin (WP#) which prevents any modifications to memory blocks whose lock-bits are set.

The DD28F032SA contains three types of Status Registers to accomplish various functions:

- A Compatible Status Register (CSR) which is 100% compatible with the 28F008SA FlashFile memory's Status Register. This register, when used alone, provides a straightforward upgrade capability to the DD28F032SA from a 28F008SA-based design.
- A Global Status Register (GSR) which informs the system of Command Queue status, Page Buffer status, and overall Write State Machine (WSM) status.
- 64 Block Status Registers (BSRs) which provide block-specific status information such as the block lock-bit status.

The GSR and BSR memory maps for byte-wide and word-wide modes are shown in Figures 4 and 5.

The DD28F032SA incorporates an open drain RY/BY# output pin. This feature allows the user to OR-tie many RY/BY# pins together in a multiple memory configuration such as a Resident Flash Array. Other configurations of the RY/BY# pin are enabled via special CUI commands and are described in detail in the *16-Mbit Flash Product Family User's Manual*.

The DD28F032SA also incorporates three chip-enable input pins, CE₀#, CE₁# and CE₂#. The active low combination of CE₀# and CE₁# controls the first 28F016SA. The active low combination of CE₀# and CE₂# controls the second 28F016SA.

The BYTE# pin allows either x8 or x16 read/programs to the DD28F032SA. BYTE# at logic low selects 8-bit mode with address A₀ selecting between low byte and high byte. On the other hand, BYTE# at logic high enables 16-bit operation with address A₁ becoming the lowest order address and address A₀ is not used (don't care). A device block diagram is shown in Figure 1.

The DD28F032SA is specified for a maximum access time of 70 ns (t_{ACC}) at 5.0V operation (4.75V to 5.25V) over the commercial temperature range (0°C to +70°C). A corresponding maximum access time of 150 ns at 3.3V (3.0V to 3.6V and 0°C to +70°C) is achieved for reduced power consumption applications.

The DD28F032SA incorporates an Automatic Power Saving (APS) feature which substantially reduces the active current when the device is in static mode of operation (addresses not switching).

A deep power-down mode of operation is invoked when the RP# (called PWD# on the 28F008SA) pin is driven low. This mode provides additional write protection by acting as a device reset pin during power transitions. In the deep power-down state, the WSM is reset (any current operation will abort) and the CSR, GSR and BSR registers are cleared.

A CMOS standby mode of operation is enabled when either CE₀#, or both CE₁# and CE₂#, transition high and RP# stays high with all input control pins at CMOS levels.

2.0 DEVICE PINOUT

The DD28F032SA Standard 56-Lead Dual Die TSOP Type I pinout configuration is shown in Figure 2.



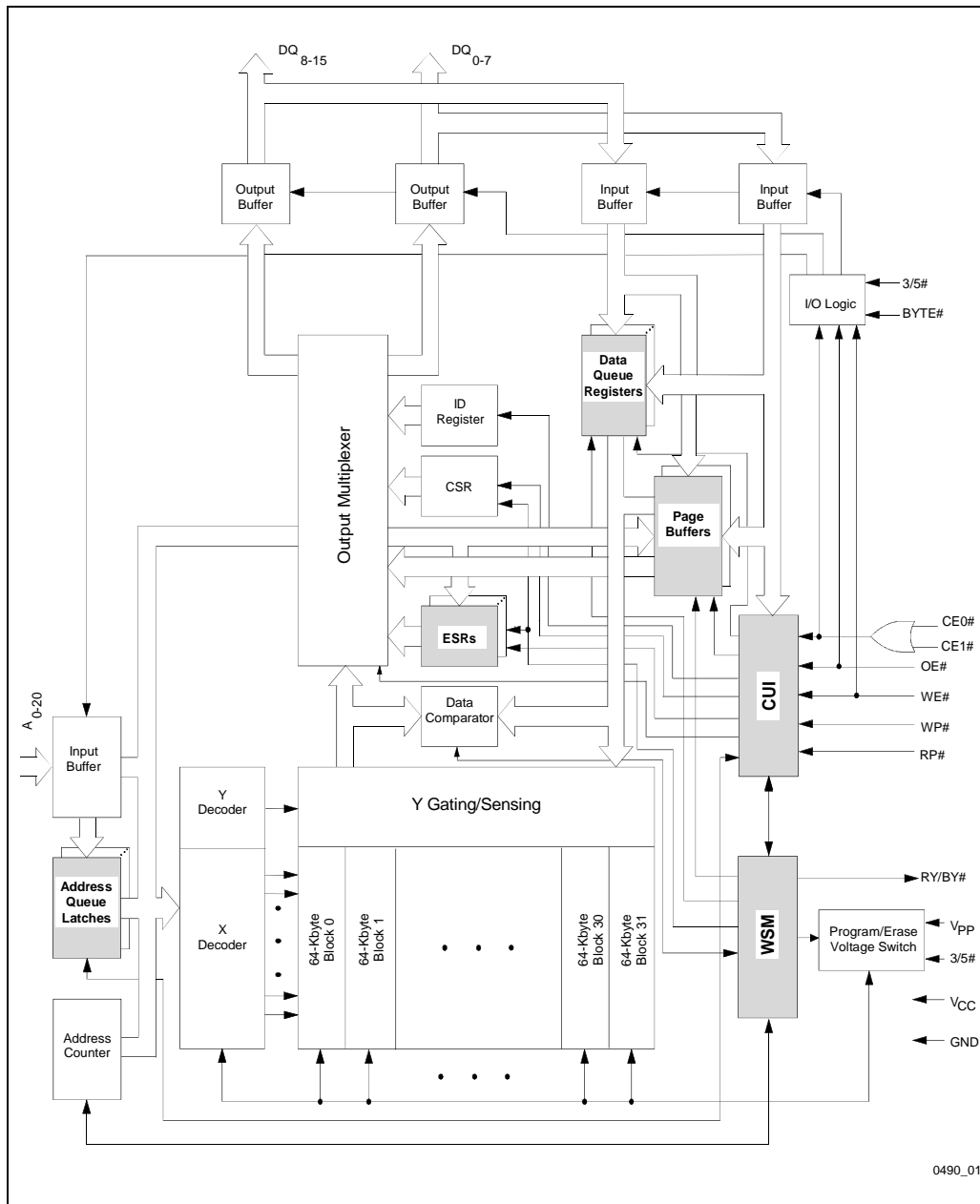

Figure 1. Block Diagram of 16-Mbit Devices in DD28F032SA
Architectural Evolution Includes Page Buffers, Queue Registers and Extended Registers

2.1 Lead Descriptions

Symbol	Type	Name and Function
A ₀	INPUT	BYTE-SELECT ADDRESS: Selects between high and low byte when device is in x8 mode. This address is latched in x8 data programs. Not used in x16 mode (i.e., the A ₀ input buffer is turned off when BYTE# is high).
A ₁ –A ₁₅	INPUT	WORD-SELECT ADDRESSES: Select a word within one 64-Kbyte block. A ₆₋₁₅ selects 1 of 1024 rows, and A ₁₋₅ selects 16 of 512 columns. These addresses are latched during data programs.
A ₁₆ –A ₂₀	INPUT	BLOCK-SELECT ADDRESSES: Select 1 of 32 erase blocks in each of the two 28F016SAs. These addresses are latched during data programs, block erase and lock block operations.
DQ ₀ –DQ ₇	INPUT/OUTPUT	LOW-BYTE DATA BUS: Inputs data and commands during CUI write cycles. Outputs array, buffer, identifier or status data in the appropriate read mode. Floated when the chip is de-selected or the outputs are disabled.
DQ ₈ –DQ ₁₅	INPUT/OUTPUT	HIGH-BYTE DATA BUS: Inputs data during x16 data program operations. Outputs array, buffer or identifier data in the appropriate read mode; not used for Status Register reads. Floated when the chip is de-selected or the outputs are disabled.
CE ₀ # CE _x # = CE ₁ # or CE ₂ #	INPUT	CHIP ENABLE INPUTS: Activate the device's control logic, input buffers, decoders and sense amplifiers. CE ₀ #/CE ₁ # enable/disable the first 28F016SA (16 Mbit No. 1) while CE ₀ #/CE ₂ # enable/disable the second 28F016SA (16 Mbit No. 2). CE ₀ # active low enables chip operation while CE ₁ # or CE ₂ # select between the first and second device, respectively. CE ₁ # and CE ₂ # must not be active low simultaneously. Reference Table 3.0.
RP#	INPUT	RESET/POWER-DOWN: RP# low places the device in a deep power-down state. All circuits that burn static power, even those circuits enabled in standby mode, are turned off. When returning from deep power-down, a recovery time is required to allow these circuits to power-up. When RP# goes low, any current or pending WSM operation(s) are terminated, and the device is reset. All Status Registers return to ready (with all status flags cleared).
OE#	INPUT	OUTPUT ENABLE: Gates device data through the output buffers when low. The outputs float to tri-state off when OE# is high. NOTE: CE _x # overrides OE#, and OE# overrides WE#.
WE#	INPUT	WRITE ENABLE: Controls access to the CUI, Page Buffers, Data Queue Registers and Address Queue Latches. WE# is active low, and latches both address and data (command or array) on its rising edge.
RY/BY#	OPEN DRAIN OUTPUT	READY/BUSY: Indicates status of the internal WSM. When low, it indicates that the WSM is busy performing an operation. RY/BY# high indicates that the WSM is ready for new operations (or WSM has completed all pending operations), or block erase is suspended, or the device is in deep power-down mode. This output is always active (i.e., not floated to tri-state off when OE# or CE ₀ #/CE ₁ #/CE ₂ # are high), except if a RY/BY# Pin Disable command is issued.

2.1 Lead Descriptions (Continued)

Symbol	Type	Name and Function
WP#	INPUT	WRITE PROTECT: Erase blocks can be locked by writing a nonvolatile lock-bit for each block. When WP# is low, those locked blocks as reflected by the Block-Lock Status bits (BSR.6), are protected from inadvertent data programs or block erases. When WP# is high, all blocks can be written or erased regardless of the state of the lock-bits. The WP# input buffer is disabled when RP# transitions low (deep power-down mode).
BYTE#	INPUT	BYTE ENABLE: BYTE# low places device in x8 mode. All data is then input or output on DQ ₀₋₇ , and DQ ₈₋₁₅ float. Address A ₀ selects between the high and low byte. BYTE# high places the device in x16 mode, and turns off the A ₀ input buffer. Address A ₁ then becomes the lowest order address.
3/5#	INPUT	3.3/5.0 VOLT SELECT: 3/5# high configures internal circuits for 3.3V operation. 3/5# low configures internal circuits for 5.0V operation. NOTES: Reading the array with 3/5# high in a 5.0V system could damage the device. There is a significant delay from 3/5# switching to valid data.
V _{PP}	SUPPLY	ERASE/PROGRAM POWER SUPPLY: For erasing memory array blocks or writing words/bytes/pages into the flash array.
V _{CC}	SUPPLY	DEVICE POWER SUPPLY (3.3V ± 0.3V, 5.0V ± 0.5V, 5.0V ± 0.25V): Do not leave any power pins floating.
GND	SUPPLY	GROUND FOR ALL INTERNAL CIRCUITRY: Do not leave any ground pins floating.
NC		NO CONNECT: Lead may be driven or left floating.

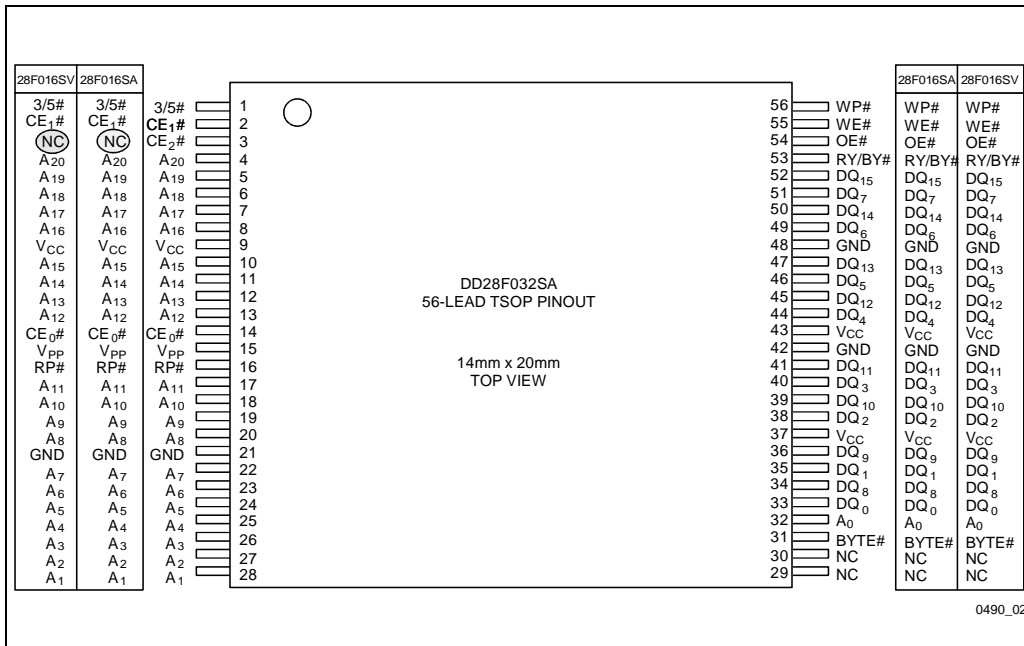

Figure 2. Dual Die TSOP Pinout Configuration

3.0 MODES OF OPERATION

RP#	CE ₀ #	CE ₁ #	CE ₂ #	28F016SA No. 1	28F016SA No. 2	DD28F032SA Chip
0	X	X	X	DPD	DPD	DPD
1	1	X	X	Standby	Standby	Standby
1	0	0	1	Standby	Active	Active
1	0	1	0	Active	Standby	Active
1	0	1	1	Standby	Standby	Standby
1	0	0	0	Illegal Condition		

NOTES:

X = Don't Care

DPD = Deep Power-Down

28F016SA No. 1 = First 16-Mbit Device

28F016SA No. 2 = Second 16-Mbit Device

4.0 MEMORY MAPS

1FFFFF	64-Kbyte Block	31	1FFFFF	64-Kbyte Block	63
1F0000			1F0000	64-Kbyte Block	62
1EFFFF	64-Kbyte Block	30	1EFFFF	64-Kbyte Block	61
1E0000			1E0000	64-Kbyte Block	60
1DFFFF	64-Kbyte Block	29	1DFFFF	64-Kbyte Block	59
1D0000			1D0000	64-Kbyte Block	58
1CFFFF	64-Kbyte Block	28	1CFFFF	64-Kbyte Block	57
1C0000			1C0000	64-Kbyte Block	56
1BFFFF	64-Kbyte Block	27	1BFFFF	64-Kbyte Block	55
1B0000			1B0000	64-Kbyte Block	54
1AFFFF	64-Kbyte Block	26	1AFFFF	64-Kbyte Block	53
1A0000			1A0000	64-Kbyte Block	52
19FFFF	64-Kbyte Block	25	19FFFF	64-Kbyte Block	51
190000			190000	64-Kbyte Block	50
18FFFF	64-Kbyte Block	24	18FFFF	64-Kbyte Block	49
180000			180000	64-Kbyte Block	48
17FFFF	64-Kbyte Block	23	17FFFF	64-Kbyte Block	47
170000			170000	64-Kbyte Block	46
16FFFF	64-Kbyte Block	22	16FFFF	64-Kbyte Block	45
160000			160000	64-Kbyte Block	44
15FFFF	64-Kbyte Block	21	15FFFF	64-Kbyte Block	43
150000			150000	64-Kbyte Block	42
14FFFF	64-Kbyte Block	20	14FFFF	64-Kbyte Block	41
140000			140000	64-Kbyte Block	40
13FFFF	64-Kbyte Block	19	13FFFF	64-Kbyte Block	39
130000			130000	64-Kbyte Block	38
12FFFF	64-Kbyte Block	18	12FFFF	64-Kbyte Block	37
120000			120000	64-Kbyte Block	36
11FFFF	64-Kbyte Block	17	11FFFF	64-Kbyte Block	35
110000			110000	64-Kbyte Block	34
10FFFF	64-Kbyte Block	16	10FFFF	64-Kbyte Block	33
100000			100000	64-Kbyte Block	32
0FFFFF	64-Kbyte Block	15	0FFFFF		
0F0000			0F0000		
0EFFFF	64-Kbyte Block	14	0EFFFF		
0E0000			0E0000		
0DFFFF	64-Kbyte Block	13	0DFFFF		
0D0000			0D0000		
0CFFFF	64-Kbyte Block	12	0CFFFF		
0C0000			0C0000		
0BFFFF	64-Kbyte Block	11	0BFFFF		
0B0000			0B0000		
0AFFFF	64-Kbyte Block	10	0AFFFF		
0A0000			0A0000		
09FFFF	64-Kbyte Block	9	09FFFF		
090000			090000		
08FFFF	64-Kbyte Block	8	08FFFF		
080000			080000		
07FFFF	64-Kbyte Block	7	07FFFF		
070000			070000		
06FFFF	64-Kbyte Block	6	06FFFF		
060000			060000		
05FFFF	64-Kbyte Block	5	05FFFF		
050000			050000		
04FFFF	64-Kbyte Block	4	04FFFF		
040000			040000		
03FFFF	64-Kbyte Block	3	03FFFF		
030000			030000		
02FFFF	64-Kbyte Block	2	02FFFF		
020000			020000		
01FFFF	64-Kbyte Block	1	01FFFF		
010000			010000		
00FFFF	64-Kbyte Block	0	00FFFF		
000000			000000		

28F016SA No. 1

28F016SA No. 2

0490_03

Figure 3. DD28F032SA Memory Map (Byte-Wide Mode)

4.1 Extended Status Registers Memory Map for Either 28F016SA No. 1 or 28F016SA No. 2

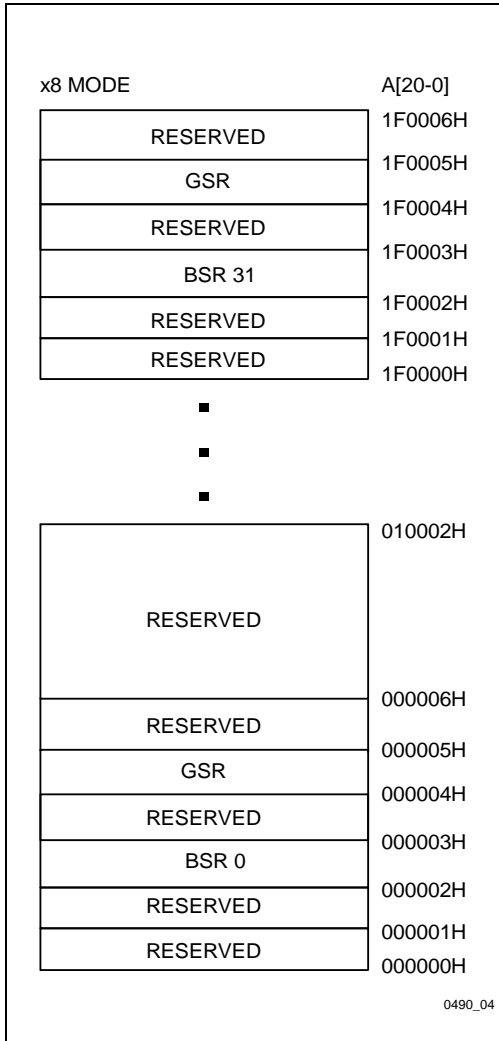

Figure 4. Extended Status Register Memory Map (Byte-Wide Mode)

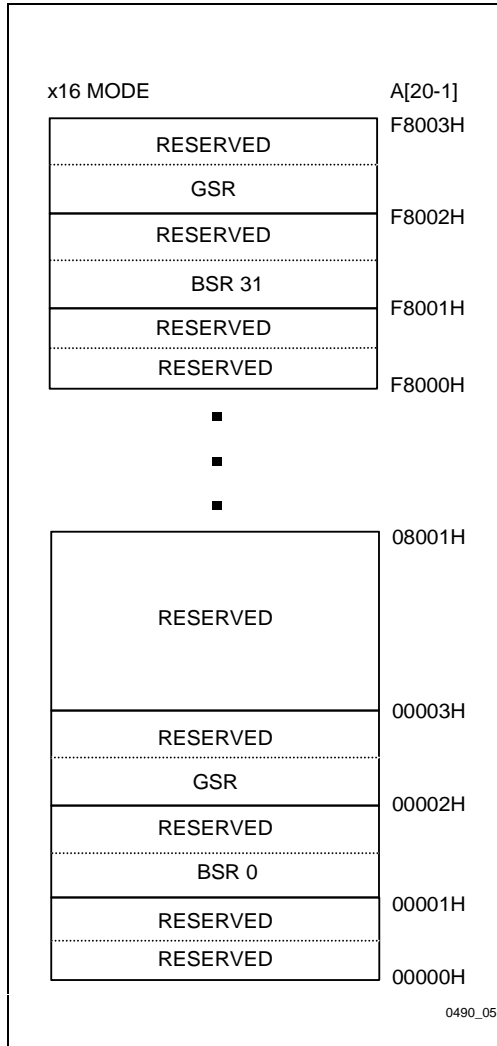

Figure 5. Extended Status Register Memory Map (Word-Wide Mode)



5.0 BUS OPERATIONS, COMMANDS AND STATUS REGISTER DEFINITIONS

5.1 Bus Operations for Word-Wide Mode (BYTE# = V_{IH})

Mode	Notes	RP#	CE _X # ⁽⁸⁾	CE ₀ #	OE#	WE#	A ₁	DQ ₀₋₁₅	RY/BY#
Read	1,2,7	V _{IH}	V _{IL}	V _{IL}	V _{IL}	V _{IH}	X	D _{OUT}	X
Output Disable	1,6,7	V _{IH}	V _{IL}	V _{IL}	V _{IH}	V _{IH}	X	High Z	X
Standby	1,6,7	V _{IH}	V _{IL} V _{IH} V _{IH}	V _{IH} V _{IL} V _{IH}	X	X	X	High Z	X
Deep Power-Down	1,3	V _{IL}	X	X	X	X	X	High Z	V _{OH}
Manufacturer ID	4	V _{IH}	V _{IL}	V _{IL}	V _{IL}	V _{IH}	V _{IL}	0089H	V _{OH}
Device ID	4	V _{IH}	V _{IL}	V _{IL}	V _{IL}	V _{IH}	V _{IH}	66A0H	V _{OH}
Write	1,5,6	V _{IH}	V _{IL}	V _{IL}	V _{IH}	V _{IL}	X	D _{IN}	X

5.2 Bus Operations for Byte-Wide Mode (BYTE# = V_{IL})

Mode	Notes	RP#	CE _X # ⁽⁸⁾	CE ₀ #	OE#	WE#	A ₀	DQ ₀₋₇	RY/BY#
Read	1,2,7	V _{IH}	V _{IL}	V _{IL}	V _{IL}	V _{IH}	X	D _{OUT}	X
Output Disable	1,6,7	V _{IH}	V _{IL}	V _{IL}	V _{IH}	V _{IH}	X	High Z	X
Standby	1,6,7	V _{IH}	V _{IL} V _{IH} V _{IH}	V _{IH} V _{IL} V _{IH}	X	X	X	High Z	X
Deep Power-Down	1,3	V _{IL}	X	X	X	X	X	High Z	V _{OH}
Manufacturer ID	4	V _{IH}	V _{IL}	V _{IL}	V _{IL}	V _{IH}	V _{IL}	89H	V _{OH}
Device ID	4	V _{IH}	V _{IL}	V _{IL}	V _{IL}	V _{IH}	V _{IH}	A0H	V _{OH}
Write	1,5,6	V _{IH}	V _{IL}	V _{IL}	V _{IH}	V _{IL}	X	D _{IN}	X

NOTES:

- X can be V_{IH} or V_{IL} for address or control pins except for RY/BY#, which is either V_{OL} or V_{OH}.
- RY/BY# output is open drain. When the WSM is ready, block erase is suspended or the device is in deep power-down mode, RY/BY# will be at V_{OH} if it is tied to V_{CC} through a resistor. RY/BY# at V_{OH} is independent of OE# while a WSM operation is in progress.
- RP# at GND ± 0.2V ensures the lowest deep power-down current.
- A₀ and A₁ at V_{IL} provide device manufacturer codes in x8 and x16 modes respectively. A₀ and A₁ at V_{IH} provide device ID codes in x8 and x16 modes respectively. All other addresses are set to zero.
- Commands for different block erase operations, data program operations or lock-block operations can only be successfully completed when V_{PP} = V_{PPH}.
- While the WSM is running, RY/BY# in level-mode (default) stays at V_{OL} until all operations are complete. RY/BY# goes to V_{OH} when the WSM is not busy or in erase suspend mode.
- RY/BY# may be at V_{OL} while the WSM is busy performing various operations; for example, a Status Register read during a data program operation.
- CE_X# = CE₁# or CE₂#.

5.3 28F008SA Compatible Mode Command Bus Definitions

Command	Notes	First Bus Cycle			Second Bus Cycle		
		Oper	Addr	Data	Oper	Addr	Data
Read Array		Write	X	xxFFH	Read	AA	AD
Intelligent Identifier	1	Write	X	xx90H	Read	IA	ID
Read Compatible Status Register	2	Write	X	xx70H	Read	X	CSRD
Clear Status Register	3	Write	X	xx50H			
Word/Byte Program		Write	X	xx40H	Write	PA	PD
Alternate Word/Byte Program		Write	X	xx10H	Write	PA	PD
Block Erase/Confirm		Write	X	xx20H	Write	BA	xxD0H
Erase Suspend/Resume		Write	X	xxB0H	Write	X	xxD0H

ADDRESS

A = Array Address
 BA = Block Address
 IA = Identifier Address
 PA = Program Address
 X = Don't Care

DATA

AD = Array Data
 CSRD = CSR Data
 ID = Identifier Data
 PD = Program Data

NOTES:

- Following the Intelligent Identifier command, two read operations access the manufacturer and device signature codes.
- The CSR is automatically available after device enters data program, block erase, or suspend operations.
- Clears CSR.3, CSR.4 and CSR.4. Also clears GSR.4 and all BSR.4 and BSR.2 bits.
- The upper byte of the data bus (DQ₈₋₁₅) during command writes is a "Don't Care" in x16 operation of the device.

See Status Register definitions.



5.4 28F016SA-Performance Enhancement Command Bus Definitions

Command	Mode	Notes	First Bus Cycle			Second Bus Cycle			Third Bus Cycle		
			Oper	Addr	Data ⁽¹²⁾	Oper	Addr	Data ⁽¹²⁾	Oper	Addr	Data
Read Extended Status Register		1	Write	X	xx71H	Read	RA	GSRD BSRD			
Page Buffer Swap		7	Write	X	xx72H						
Read Page Buffer			Write	X	xx75H	Read	PBA	PD			
Single Load to Page Buffer			Write	X	xx74H	Write	PBA	PD			
Sequential Load to Page Buffer	x8	4,6,10	Write	X	xxE0H	Write	X	BCL	Write	X	BCH
	x16	4,5,6,10	Write	X	xxE0H	Write	X	WCL	Write	X	WCH
Page Buffer Write to Flash	x8	3,4,9,10	Write	X	xx0CH	Write	A ₀	BC(L,H)	Write	PA	BC(H,L)
	x16	4,5,10	Write	X	xx0CH	Write	X	WCL	Write	PA	WCH
Two-Byte Write	x8	3	Write	X	xxFBH	Write	A ₀	WD(L,H)	Write	PA	WD(H,L)
Lock Block/Confirm			Write	X	xx77H	Write	BA	xxD0H			
Upload Status Bits/Confirm		2	Write	X	xx97H	Write	X	xxD0H			
Upload Device Information			Write	X	xx99H	Write	X	xxD0H			
Erase All Unlocked Blocks/Confirm			Write	X	xxA7H	Write	X	xxD0H			
RY/BY# Enable to Level-Mode		8	Write	X	xx96H	Write	X	xx01H			
RY/BY# Pulse-On-Write		8	Write	X	xx96H	Write	X	xx02H			
RY/BY# Pulse-On-Erase		8	Write	X	xx96H	Write	X	xx03H			
RY/BY# Disable		8	Write	X	xx96H	Write	X	xx04H			
Sleep		11	Write	X	xxF0H						
Abort			Write	X	xx80H						

ADDRESS

BA = Block Address
 PBA = Page Buffer Address
 RA = Extended Register Address
 PA = Program Address
 X = Don't Care

DATA

AD = Array Data
 PD = Page Buffer Data
 BSRD = BSR Data
 GSRD = GSR Data
 WC (L,H) = Word Count (Low, High)
 BC (L,H) = Byte Count (Low, High)
 WD (L,H) = Write Data (Low, High)

NOTES:

1. RA can be the GSR address or any BSR address. See Figures 4 and 5 for Extended Status Register Memory Maps.
2. Upon device power-up, all BSR lock-bits come up locked. The Upload Status Bits command must be written to reflect the actual lock-bit status.
3. A_0 is automatically complemented to load the second byte of data. BYTE# must be at V_L . The A_0 value determines which WD/BC is supplied first: $A_0 = 0$ looks at the WDL/BCL, $A_0 = 1$ looks at the WDH/BCH.
4. BCH/WCH must be at 00H for this product because of the 256-byte (128-word) Page Buffer size and to avoid writing the Page Buffer contents to more than one 256-byte segment within an array block. They are simply shown for future Page Buffer expandability.
5. In x16 mode, only the lower byte DQ_{0-7} is used for WCL and WCH. The upper byte DQ_{8-15} is a don't care.
6. PBA and PD (whose count is given in cycles 2 and 3) are supplied starting in the fourth cycle, which is not shown.
7. This command allows the user to swap between available Page Buffers (0 or 1).
8. These commands reconfigure the RY/BY# output to one of two pulse-modes or enable and disable the RY/BY# function.
9. Program address, PA, is the destination address in the flash array which must match the source address in the Page Buffer. Refer to the *16-Mbit Flash Product Family User's Manual*.
10. BCL = 00H corresponds to a byte count of 1. Similarly, WCL = 00H corresponds to a word count of 1.
11. To ensure that the DD28F032SA's power consumption during sleep mode reads the deep power-down current level, the system also needs to de-select the chip by taking either or both $CE_0\#$ or $CE_1\#/CE_2\#$ high.
12. The upper byte of the data bus (DQ_{8-15}) during command programs is a "Don't Care" in x16 operation of the device.

5.5 Compatible Status Register

WSMS	ESS	ES	DWS	VPPS	R	R	R
7	6	5	4	3	2	1	0

NOTES:	
<p>CSR.7 = WRITE STATE MACHINE STATUS 1 = Ready 0 = Busy</p>	<p>RY/BY# output or WSMS bit must be checked to determine completion of an operation (erase suspend, block erase or data program) before the appropriate Status bit (ESS, ES or DWS) is checked for success.</p>
<p>CSR.6 = ERASE-SUSPEND STATUS 1 = Erase Suspended 0 = Erase In Progress/Completed</p>	
<p>CSR.5 = ERASE STATUS 1 = Error in Block Erasure 0 = Successful Block Erase</p>	<p>If DWS and ES are set to "1" during a block erase attempt, an improper command sequence was entered. Clear the CSR and attempt the operation again.</p>
<p>CSR.4 = DATA WRITE STATUS 1 = Error in Data Program 0 = Data Program Successful</p>	
<p>CSR.3 = V_{PP} STATUS 1 = V_{PP} Low Detect, Operation Abort 0 = V_{PP} OK</p>	<p>The VPPS bit, unlike an A/D converter, does not provide continuous indication of V_{PP} level. The WSM interrogates V_{PP}'s level only after the Data Program or Block Erase command sequences have been entered, and informs the system if V_{PP} has not been switched on. VPPS is not guaranteed to report accurate feedback between V_{PPL} and V_{PPH}.</p>
<p>CSR.2-0 = RESERVED FOR FUTURE ENHANCEMENTS These bits are reserved for future use; mask them out when polling the CSR.</p>	

5.6 Global Status Register

WSMS	OSS	DOS	DSS	QS	PBAS	PBS	PBSS
7	6	5	4	3	2	1	0

		NOTES:
<p>GSR.7 = WRITE STATE MACHINE STATUS 1 = Ready 0 = Busy</p>		<p>[1] RY/BY# output or WSMS bit must be checked to determine completion of an operation (block lock, erase suspend, any RY/BY# reconfiguration, Upload Status Bits, block erase or data program) before the appropriate Status bit (OSS or DOS) is checked for success.</p>
<p>GSR.6 = OPERATION SUSPEND STATUS 1 = Operation Suspended 0 = Operation in Progress/Completed</p>		
<p>GSR.5 = DEVICE OPERATION STATUS 1 = Operation Unsuccessful 0 = Operation Successful or Currently Running</p>		
<p>GSR.4 = DEVICE SLEEP STATUS 1 = Device in Sleep 0 = Device Not in Sleep</p>		
<p>MATRIX = <u>5/4</u> 0 0 = Operation Successful or Currently Running 0 1 = Device in Sleep Mode or Pending Sleep 1 0 = Operation Unsuccessful 1 1 = Operation Unsuccessful or Aborted</p>		<p>If operation currently running, then GSR.7 = 0. If device pending sleep, then GSR.7 = 0.</p> <p>Operation aborted: unsuccessful due to Abort command.</p>
<p>GSR.3 = QUEUE STATUS 1 = Queue Full 0 = Queue Available</p>		
<p>GSR.2 = PAGE BUFFER AVAILABLE STATUS 1 = One or Two Page Buffers Available 0 = No Page Buffer Available</p>		<p>Each 28F016SA device contains two Page Buffers.</p>
<p>GSR.1 = PAGE BUFFER STATUS 1 = Selected Page Buffer Ready 0 = Selected Page Buffer Busy</p>		<p>Selected Page Buffer is currently busy with WSM operation</p>
<p>GSR.0 = PAGE BUFFER SELECT STATUS 1 = Page Buffer 1 Selected 0 = Page Buffer 0 Selected</p>		

NOTE:

- When multiple operations are queued, checking BSR.7 only provides indication of completion for that particular block. GSR.7, or CSR.7, provides indication when all queued operations are completed.

5.7 Block Status Register

BS	BLS	BOS	BOAS	QS	VPPS	R	R
7	6	5	4	3	2	1	0

<p>BSR.7 = BLOCK STATUS 1 = Ready 0 = Busy</p> <p>BSR.6 = BLOCK LOCK STATUS 1 = Block Unlocked for Program/Erase 0 = Block Locked for Program/Erase</p> <p>BSR.5 = BLOCK OPERATION STATUS 1 = Operation Unsuccessful 0 = Operation Successful or Currently Running</p> <p>BSR.4 = BLOCK OPERATION ABORT STATUS 1 = Operation Aborted 0 = Operation Not Aborted</p> <p>MATRIX <u>5/4</u> 0 0 = Operation Successful or Currently Running 0 1 = Not a Valid Combination 1 0 = Operation Unsuccessful 1 1 = Operation Aborted</p> <p>BSR.3 = QUEUE STATUS 1 = Queue Full 0 = Queue Available</p> <p>BSR.2 = V_{PP} STATUS 1 = V_{PP} Low Detect, Operation Abort 0 = V_{PP} OK</p> <p>BSR.1-0 = RESERVED FOR FUTURE ENHANCEMENTS These bits are reserved for future use; mask them out when polling the BSRs.</p>	<p>NOTES: [1] RY/BY# output or BS bit must be checked to determine completion of an operation (block lock, erase suspend, any RY/BY# reconfiguration, Upload Status Bits, block erase or data program) before the appropriate Status bits (BOS, BLS) is checked for success.</p> <p>The BOAS bit will not be set until BSR.7 = 1.</p> <p>Operation halted via Abort command.</p>
--	---

NOTE:

- When multiple operations are queued, checking BSR.7 only provides indication of completion for that particular block. GSR.7, or CSR.7, provides indication when all queued operations are completed.

6.0 ELECTRICAL SPECIFICATIONS

6.1 Absolute Maximum Ratings*

Temperature Under Bias0°C to +80°C

Storage Temperature-65°C to +125°C

NOTICE: This is a production datasheet. The specifications are subject to change without notice. Verify with your local Intel Sales office that you have the latest datasheet before finalizing a design.

* **WARNING:** *Stressing the device beyond the "Absolute Maximum Ratings" may cause permanent damage. These are stress ratings only. Operation beyond the "Operating Conditions" is not recommended and extended exposure beyond the "Operating Conditions" may affect device reliability.*

$V_{CC} = 3.3V \pm 0.3V$ Systems

Symbol	Parameter	Notes	Min	Max	Units	Test Conditions
T_A	Operating Temperature, Commercial	1	0	70	°C	Ambient Temperature
V_{CC}	V_{CC} with Respect to GND	2	-0.2	7.0	V	
V_{PP}	V_{PP} Supply Voltage with Respect to GND	2,3	-0.2	14.0	V	
V	Voltage on any Pin (except V_{CC}, V_{PP}) with Respect to GND	2	-0.5	$V_{CC} + 0.5$	V	
I	Current into Any Non-Supply Pin	5		± 30	mA	
I_{OUT}	Output Short Circuit Current	4		100	mA	

$V_{CC} = 5.0V \pm 0.5V, V_{CC} = 5.0V \pm 0.25V$ Systems⁽⁶⁾

Symbol	Parameter	Notes	Min	Max	Units	Test Conditions
T_A	Operating Temperature, Commercial	1	0	70	°C	Ambient Temperature
V_{CC}	V_{CC} with Respect to GND	2	-0.2	7.0	V	
V_{PP}	V_{PP} Supply Voltage with Respect to GND	2,3	-0.2	14.0	V	
V	Voltage on Any Pin (except V_{CC}, V_{PP}) with Respect to GND	2	-2.0	7.0	V	
I	Current into Any Non-Supply Pin	5		± 30	mA	
I_{OUT}	Output Short Circuit Current	4		100	mA	

NOTES:

- Operating temperature is for commercial product defined by this specification.
- Minimum DC voltage is -0.5V on input/output pins. During transitions, this level may undershoot to -2.0V for periods <20 ns. Maximum DC voltage on input/output pins is $V_{CC} + 0.5V$ which, during transitions, may overshoot to $V_{CC} + 2.0V$ for periods <20 ns.
- Maximum DC voltage on V_{PP} may overshoot to +14.0V for periods <20 ns.
- Output shorted for no more than one second. No more than one output shorted at a time.
- This specification also applies to pins marked "NC."
- 5% V_{CC} specifications refer to the DD28F032SA-070 in its High Speed Test configuration.

6.2 Capacitance

For a 3.3V System:

Symbol	Parameter	Notes	Typ	Max	Units	Test Conditions
C _{IN}	Capacitance Looking into an Address/Control Pin	1	12	16	pF	T _A = +25°C, f = 1.0 MHz
C _{OUT}	Capacitance Looking into an Output Pin	1	16	24	pF	T _A = +25°C, f = 1.0 MHz
C _{LOAD}	Load Capacitance Driven by Outputs for Timing Specifications	1		50	pF	For V _{CC} = 3.3V ± 0.3V
	Equivalent Load Timing Circuit			2.5	ns	50Ω Transmission Line Delay

For a 5.0V System:

Symbol	Parameter	Notes	Typ	Max	Units	Test Conditions
C _{IN}	Capacitance Looking into an Address/Control Pin	1	12	16	pF	T _A = +25°C, f = 1.0 MHz
C _{OUT}	Capacitance Looking into an Output Pin	1	16	24	pF	T _A = +25°C, f = 1.0 MHz
C _{LOAD}	Load Capacitance Driven by Outputs for Timing Specifications	1		100	pF	For V _{CC} = 5.0V ± 0.5V
				30	pF	For V _{CC} = 5.0V ± 0.25V
	Equivalent Testing Load Circuit for V _{CC} ± 10%			2.5	ns	25Ω Transmission Line Delay
	Equivalent Testing Load Circuit for V _{CC} ± 5%			2.5	ns	83Ω Transmission Line Delay

NOTE:

1. Sampled, not 100% tested.

6.3 Timing Nomenclature

All 3.3V system timings are measured from where signals cross 1.5V.

For 5.0V systems use the standard JEDEC cross point definitions.

Each timing parameter consists of 5 characters. Some common examples are defined below:

- t_{CE} t_{ELQV} time(t) from $CE_x\#$ (E) going low (L) to the outputs (Q) becoming valid (V)
- t_{OE} t_{GLQV} time(t) from OE # (G) going low (L) to the outputs (Q) becoming valid (V)
- t_{ACC} t_{AVQV} time(t) from address (A) valid (V) to the outputs (Q) becoming valid (V)
- t_{AS} t_{AVWH} time(t) from address (A) valid (V) to WE# (W) going high (H)
- t_{DH} t_{WHDx} time(t) from WE# (W) going high (H) to when the data (D) can become undefined (X)

	Pin Characters		Pin States
A	Address Inputs	H	High
D	Data Inputs	L	Low
Q	Data Outputs	V	Valid
E	$CE_x\#$ (Chip Enable)	X	Driven, but not necessarily valid
F	BYTE# (Byte Enable)	Z	High Impedance
G	OE# (Output Enable)		
W	WE# (Write Enable)		
P	RP# (Deep Power-Down Pin)		
R	RY/BY# (Ready Busy)		
V	Any Voltage Level		
Y	3/5# Pin		
5V	V_{CC} at 4.5V Minimum		
3V	V_{CC} at 3.0V Minimum		

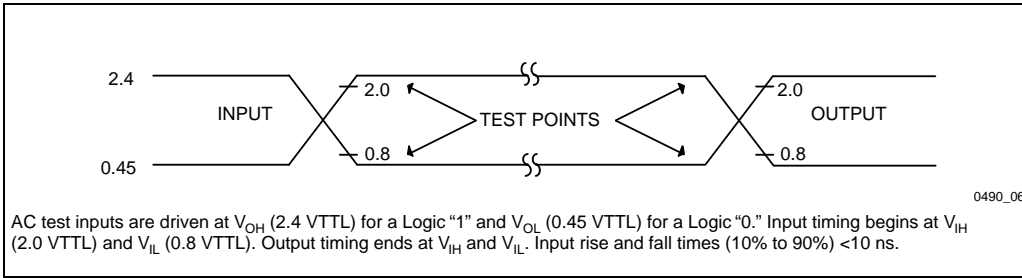

Figure 6. Transient Input/Output Reference Waveform ($V_{CC} = 5.0V$) for Standard Test Configuration⁽¹⁾

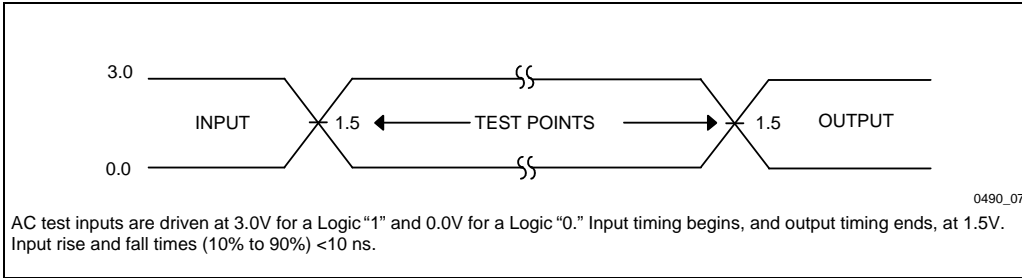

Figure 7. Transient Input/Output Reference Waveform ($V_{CC} = 3.3V$) and High Speed Reference Waveform ⁽²⁾ ($V_{CC} = 5.0V \pm 5%$)

NOTES:

1. Testing characteristics for DD28F032SA-080/DD28F032SA-100.
2. Testing characteristics for DD28F032SA-070/DD28F032SA-150.



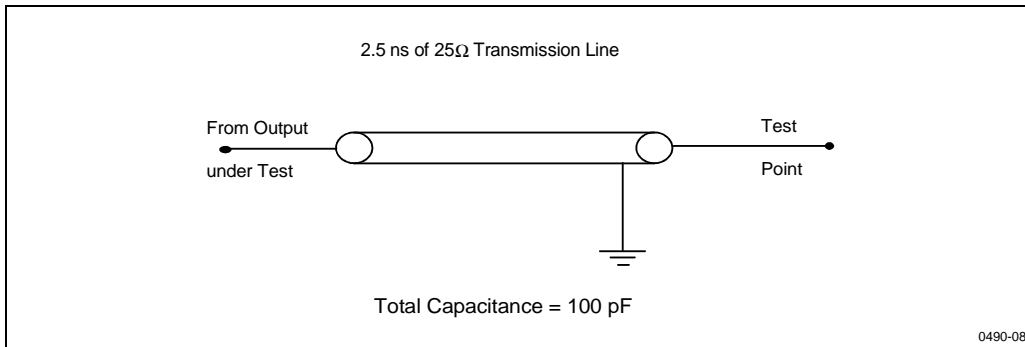

Figure 8. Transient Equivalent Testing Load Circuit ($V_{CC} = 5.0V \pm 10\%$)

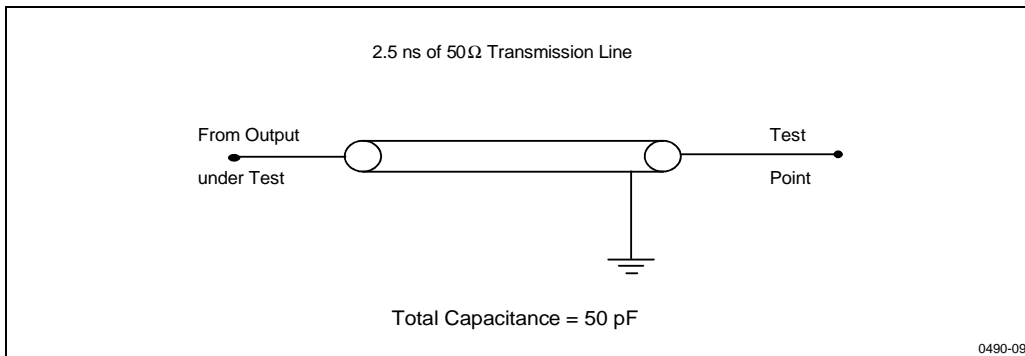

Figure 9. Transient Equivalent Testing Load Circuit ($V_{CC} = 3.3V \pm 0.3V$)

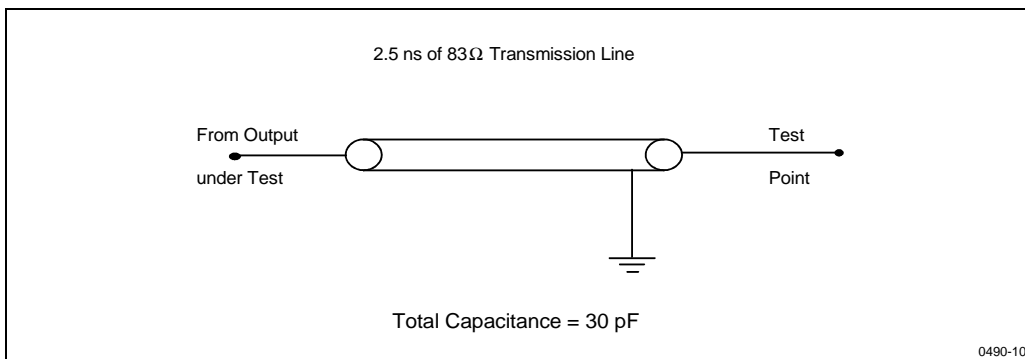

Figure 10. High Speed Transient Equivalent Testing Load Circuit ($V_{CC} = 5.0V \pm 5\%$)



6.4 DC Characteristics

$V_{CC} = 3.3V \pm 0.3V$, $T_A = 0^\circ C$ to $+70^\circ C$

3/5# = Pin Set High for 3.3V Operations

Symbol	Parameter	Notes	Min	Typ	Max	Units	Test Conditions
I_{IL}	Input Load Current	1			± 2	μA	$V_{CC} = V_{CC} \text{ Max}$ $V_{IN} = V_{CC} \text{ or GND}$
I_{LO}	Output Leakage Current	1			± 20	μA	$V_{CC} = V_{CC} \text{ Max}$ $V_{IN} = V_{CC} \text{ or GND}$
I_{CCS}	V_{CC} Standby Current	1,5,6,8		100	200	μA	$V_{CC} = V_{CC} \text{ Max}$ $CE_0\#, CE_X\#, RP\#, = V_{CC} \pm 0.2V$ $BYTE\#, WP\#, 3/5\# = V_{CC} \pm 0.2V \text{ or GND} \pm 0.2V$
				2	8	mA	$V_{CC} = V_{CC} \text{ Max}$ $CE_0\#, CE_X\#, RP\# = V_{IH}$ $BYTE\#, WP\#, 3/5\# = V_{IH} \text{ or } V_{IL}$
I_{CCD}	V_{CC} Deep Power-Down Current	1		2	10	μA	$RP\# = GND \pm 0.2V$ $BYTE\# = V_{CC} \pm 0.2V \text{ or GND} \pm 0.2V$
I_{CCR1}	V_{CC} Read Current	1,4,5,6		25	30	mA	$V_{CC} = V_{CC} \text{ Max}$ CMOS: $CE_0\#, CE_X\# = GND \pm 0.2V$, $BYTE\# = GND \pm 0.2V \text{ or } V_{CC} \pm 0.2V$, Inputs = $GND \pm 0.2V \text{ or } V_{CC} \pm 0.2V$ $f = 6.67 \text{ MHz}$, $I_{OUT} = 0 \text{ mA}$
				26	34	mA	TTL: $CE_0\#, CE_X\# = V_{IL}$, $BYTE\# = V_{IL} \text{ or } V_{IH}$, Inputs = $V_{IL} \text{ or } V_{IH}$ $f = 6.67 \text{ MHz}$, $I_{OUT} = 0 \text{ mA}$
I_{CCW}	V_{CC} Program Current for Word or Byte	1,7		8	12	mA	Program in Progress
I_{CCE}	V_{CC} Block Erase Current	1,7		6	12	mA	Block Erase in Progress
I_{CCES}	V_{CC} Erase Suspend Current	1,2,6,7		3	6	mA	$CE_0\#, CE_X\# = V_{IH}$ Block Erase Suspended
I_{PPS}	V_{PP} Standby/	1		± 2	± 20	μA	$V_{PP} \leq V_{CC}$
I_{PPR}	Read Current			130	400	μA	$V_{PP} > V_{CC}$
I_{PPD}	V_{PP} Deep Power-Down Current	1		0.4	10	μA	$RP\# = GND \pm 0.2V$

6.4 DC Characteristics (Continued)

 $V_{CC} = 3.3V \pm 0.3V$, $T_A = 0^\circ C$ to $+70^\circ C$

3/5# Pin Set High for 3.3V Operations

Symbol	Parameter	Notes	Min	Typ	Max	Units	Test Conditions
I_{PPW}	V_{PP} Program Current for Word or Byte	1		10	15	mA	$V_{PP} = V_{PPH}$ Program in Progress
I_{PPE}	V_{PP} Block Erase Current	1		4	10	mA	$V_{PP} = V_{PPH}$ Block Erase in Progress
I_{PPES}	V_{PP} Erase Suspend Current	1		130	400	μA	$V_{PP} = V_{PPH}$ Block Erase Suspended
V_{IL}	Input Low Voltage		-0.3		0.8	V	
V_{IH}	Input High Voltage		2.0		$V_{CC} \pm 0.3$	V	
V_{OL}	Output Low Voltage				0.4	V	$V_{CC} = V_{CC} \text{ Min}$ $I_{OL} = 4 \text{ mA}$
V_{OH1}	Output High Voltage		2.4			V	$V_{CC} = V_{CC} \text{ Min}$ $I_{OH} = -2.0 \text{ mA}$
V_{OH2}			$V_{CC} - 0.2$			V	$V_{CC} = V_{CC} \text{ Min}$ $I_{OH} = -100 \mu A$
V_{PPL}	V_{PP} during Normal Operations	3	0.0		6.5	V	
V_{PPH}	V_{PP} during Program/Erase Operations		11.4	12.0	12.6	V	
V_{LKO}	V_{CC} Program/Erase Lock Voltage		2.0			V	

NOTES:

- All current are in RMS unless otherwise noted. Typical values at $V_{CC} = 3.3V$, $V_{PP} = 12.0V$, $T = 25^\circ C$. These currents are valid for all product versions (package and speeds).
- I_{CCES} is specified with the device de-selected. If the device is read while in erase suspend mode, current draw is the sum of I_{CCES} and I_{CCR} .
- Block erases, word/byte programs and lock block operations are inhibited when $V_{PP} = V_{PPL}$ and not guaranteed in the range between V_{PPH} and V_{PPL} .
- Automatic Power Savings (APS) reduces I_{CCR} to $<1 \text{ mA}$ in static operation.
- CMOS Inputs are either $V_{CC} \pm 0.2V$ or $GND \pm 0.2V$. TTL Inputs are either V_{IL} or V_{IH} .
- $CE_x\# = CE_1\#$ or $CE_2\#$.
- If operating with TTL levels, add 4 mA of V_{CC} Standby Current to max I_{CCR1} , I_{CCR2} , I_{CCW} , I_{CCE} and I_{CCES} .
- Standby current levels are not reached when putting the chip in standby mode immediately after reading the page buffer. Default the device into read array or read Status Register mode before entering standby to ensure standby current levels.

6.5 DC Characteristics

$V_{CC} = 5.0V \pm 0.5V, 5.0V \pm 0.25V, T_A = 0^\circ C \text{ to } +70^\circ C$

3/5# Pin Set Low for 5.0V Operations

Symbol	Parameter	Notes	Min	Typ	Max	Units	Test Conditions
I_{IL}	Input Load Current	1			± 2	μA	$V_{CC} = V_{CC} \text{ Max}$ $V_{IN} = V_{CC} \text{ or GND}$
I_{LO}	Output Leakage Current	1			± 20	μA	$V_{CC} = V_{CC} \text{ Max}$ $V_{IN} = V_{CC} \text{ or GND}$
I_{CCS}	V_{CC} Standby Current	1,5,6,8		100	200	μA	$V_{CC} = V_{CC} \text{ Max}$ $CE_0\#, CE_X\#, RP\# = V_{CC} \pm 0.2V$ $BYTE\#, WP\#, 3/5\# = V_{CC} \pm 0.2V \text{ or GND} \pm 0.2V$
				4	8	mA	$V_{CC} = V_{CC} \text{ Max}$ $CE_0\#, CE_X\#, RP\# = V_{IH}$ $BYTE\#, WP\#, 3/5\# = V_{IH} \text{ or } V_{IL}$
I_{CCD}	V_{CC} Deep Power-Down Current	1		4	25	μA	$RP\# = GND \pm 0.2V$ $BYTE\# = V_{CC} \pm 0.2V \text{ or GND} \pm 0.2V$
I_{CCR1}	V_{CC} Read Current	1,4,5,6,7		50	60	mA	$V_{CC} = V_{CC} \text{ Max}$ CMOS: $CE_0\#, CE_X\# = GND \pm 0.2V, BYTE\# = GND \pm 0.2V \text{ or } V_{CC} \pm 0.2V,$ Inputs = $GND \pm 0.2V \text{ or } V_{CC} \pm 0.2V$ $f = 10 \text{ MHz}, I_{OUT} = 0 \text{ mA}$
				52	64	mA	TTL: $CE_0\#, CE_X\# = V_{IL},$ $BYTE\# = V_{IL} \text{ or } V_{IH},$ Inputs = $V_{IL} \text{ or } V_{IH}$ $f = 10 \text{ MHz}, I_{OUT} = 0 \text{ mA}$
I_{CCR2}	V_{CC} Read Current	1,4,5,6,7		30	35	mA	$V_{CC} = V_{CC} \text{ Max}$ CMOS: $CE_0\#, CE_X\# = GND \pm 0.2V, BYTE\# = GND \pm 0.2V \text{ or } V_{CC} \pm 0.2V$ Inputs = $GND \pm 0.2V \text{ or } V_{CC} \pm 0.2V$ $f = 5 \text{ MHz}, I_{OUT} = 0 \text{ mA}$
				32	39	mA	TTL: $CE_0\#, CE_X\# = V_{IL},$ $BYTE\# = V_{IL} \text{ or } V_{IH},$ Inputs = $V_{IL} \text{ or } V_{IH}$ $f = 5 \text{ MHz}, I_{OUT} = 0 \text{ mA}$
I_{CCW}	V_{CC} Prog. Current for Word or Byte	1,7		25	35	mA	Program in Progress

6.5 DC Characteristics (Continued)

 $V_{CC} = 5.0V \pm 0.5V$, $5.0V \pm 0.25V$, $T_A = 0^\circ C$ to $+70^\circ C$
 3/5# Pin Set Low for 5.0V Operations

Symbol	Parameter	Notes	Min	Typ	Max	Units	Test Conditions
I_{CCE}	V_{CC} Block Erase Current	1,7		18	25	mA	Block Erase in Progress
I_{CCES}	V_{CC} Erase Suspend Current	1,2,6,7		5	10	mA	$CE_0\#, CE_x\# = V_{IH}$ Block Erase Suspended
I_{PPS}	V_{PP} Standby/ Read Current	1		± 2	± 20	μA	$V_{PP} \leq V_{CC}$
I_{PPR}				130	400	μA	$V_{PP} > V_{CC}$
I_{PPD}	V_{PP} Deep Power-Down Current	1		0.4	10	μA	$RP\# = GND \pm 0.2V$
I_{PPW}	V_{PP} Prog. Current for Word or Byte	1		7	12	mA	$V_{PP} = V_{PPH}$ Program in Progress
I_{PPE}	V_{PP} Block Erase Current	1		5	10	mA	$V_{PP} = V_{PPH}$ Block Erase in Progress
I_{PPES}	V_{PP} Erase Suspend Current	1		130	400	μA	$V_{PP} = V_{PPH}$ Block Erase Suspended
V_{IL}	Input Low Voltage		-0.5		0.8	V	
V_{IH}	Input High Voltage		2.0		$V_{CC} + 0.5$	V	
V_{OL}	Output Low Voltage				0.45	V	$V_{CC} = V_{CC} \text{ Min}$, $I_{OL} = 5.8 \text{ mA}$
V_{OH1}	Output High Voltage		0.85 V_{CC}			V	$V_{CC} = V_{CC} \text{ Min}$, $I_{OH} = -2.5 \text{ mA}$
V_{OH2}			$V_{CC} - 0.4$				$V_{CC} = V_{CC} \text{ Min}$, $I_{OH} = -100 \mu A$
V_{PPL}	V_{PP} during Normal Operations	3	0.0		6.5	V	
V_{PPH}	V_{PP} during Prog. Erase Operations		11.4	12.0	12.6	V	
V_{LKO}	V_{CC} Program/Erase Lock Voltage		2.0			V	

NOTES:

- All currents are in RMS unless otherwise noted. Typical values at $V_{CC} = 5.0V$, $V_{PP} = 12.0V$, $T = +25^\circ C$. These currents are valid for all product versions (package and speeds).
- I_{CCES} is specified with the device de-selected. If the device is read while in erase suspend mode, current draw is the sum of I_{CCES} and I_{CCR} .
- Block erases, word/byte programs and lock block operations are inhibited when $V_{PP} = V_{PPL}$ and not guaranteed in the range between V_{PPH} and V_{PPL} .
- Automatic Power Saving (APS) reduces I_{CCR} to $<2 \text{ mA}$ in static operation.
- CMOS Inputs are either $V_{CC} \pm 0.2V$ or $GND \pm 0.2V$. TTL Inputs are either V_{IL} or V_{IH} .
- $CE_x\# = CE_1\#$ or $CE_2\#$.
- If operating with TTL levels, add 4 mA of V_{CC} standby current. to max I_{CCR1} , I_{CCR2} , I_{CCW} , I_{CCE} and I_{CCES} .
- Standby current levels are not reached when putting the chip in standby mode immediately after reading the page buffer. Default the device into read array or read Status Register mode before entering standby to ensure standby current levels.

6.6 AC Characteristics—Read Only Operations(1) $V_{CC} = 3.3V \pm 0.3V$, $T_A = 0^\circ C$ to $+70^\circ C$

Versions (5)			DD28F032SA-150		Units
Symbol	Parameter	Notes	Min	Max	
t_{AVAV}	Read Cycle Time		150		ns
t_{AVQV}	Address to Output Delay			150	ns
t_{ELQV}	$CE_x\#$ to Output Delay	2		150	ns
t_{PHQV}	RP# High to Output Delay			750	ns
t_{GLQV}	OE# to Output Delay	2		50	ns
t_{ELQX}	$CE_x\#$ to Output in Low Z	3	0		ns
t_{EHQZ}	$CE_x\#$ to Output in High Z	3		35	ns
t_{GLQX}	OE# to Output in Low Z	3	0		ns
t_{GHQZ}	OE# to Output in High Z	3		20	ns
t_{OH}	Output Hold from Address, $CE_x\#$ or OE# Change, Whichever Occurs First	3	0		ns
t_{FLQV} t_{FHQV}	BYTE# to Output Delay	3		150	ns
t_{FLQZ}	BYTE# Low to Output in High Z	3		40	ns
t_{ELFL} t_{ELFH}	$CE_x\#$ Low to BYTE# High or Low	3		5	ns

For Extended Status Register Reads

t_{AVEL}	Address Setup to $CE_x\#$ Going Low	3,4	0		ns
t_{AVGL}	Address Setup to OE# Going Low	3,4	0		ns

6.6 AC Characteristics—Read Only Operations⁽¹⁾ (Continued)

 $V_{CC} = 5.0V \pm 0.5V, 5.0V \pm 0.25V, T_A = 0^\circ C \text{ to } +70^\circ C$

Versions ⁽⁵⁾		V _{CC} ± 5%	DD28F032SA-070 ⁽⁶⁾						Units
		V _{CC} ± 10%			DD28F032SA-080 ⁽⁷⁾		DD28F032SA-100 ⁽⁷⁾		
Sym	Parameter	Notes	Min	Max	Min	Max	Min	Max	
t _{AVAV}	Read Cycle Time		70		80		100		ns
t _{AVQV}	Address to Output Delay			70		80		100	ns
t _{ELQV}	CE _x # to Output Delay	2		70		80		100	ns
t _{PHQV}	RP# to Output Delay			400		480		550	ns
t _{GLQV}	OE# to Output Delay	2		30		35		40	ns
t _{ELQX}	CE _x # to Output in Low Z	3	0		0		0		ns
t _{EHQZ}	CE _x # to Output in High Z	3		25		30		30	ns
t _{GLQX}	OE# to Output in Low Z	3	0		0		0		ns
t _{GHQZ}	OE# to Output in High Z	3		25		15		15	ns
t _{OH}	Output Hold from Address, CE _x # or OE# Change, Whichever Occurs First	3	0		0		0		ns
t _{FLQV} t _{FHQV}	BYTE# to Output Delay	3		70		80		100	ns
t _{FLQZ}	BYTE# Low to Output in High Z	3		25		30		30	ns
t _{ELFL} t _{ELFH}	CE _x # Low to BYTE# High or Low	3		5		5		5	ns

For Extended Status Register Reads

t _{AVEL}	Address Setup to CE _x # Going Low	3,4	0		0		0		ns
t _{AVGL}	Address Setup to OE# Going Low	3,4	0		0		0		ns

NOTES:

1. See AC Input/Output Reference Waveforms for timing measurements, Figures 6 and 7.
2. OE# may be delayed up to $t_{ELQV} - t_{GLQV}$ after the falling edge of CE_x# without impact in t_{ELQV} .
3. Sampled, not 100% tested.
4. This timing parameter is used to latch the correct BSR data onto the outputs.
5. Device speeds are defined as:
 - 70/80 ns at $V_{CC} = 5.0V$ equivalent to
 - 150 ns at $V_{CC} = 3.3V$
 - 100 ns at $V_{CC} = 5.0V$ equivalent to
 - 150 ns at $V_{CC} = 3.3V$
6. See AC Input/Output Reference Waveforms and AC Testing Load Circuits for High Speed Test Configuration.
7. See Standard AC Input/Output Reference Waveforms and AC Testing Load Circuit.

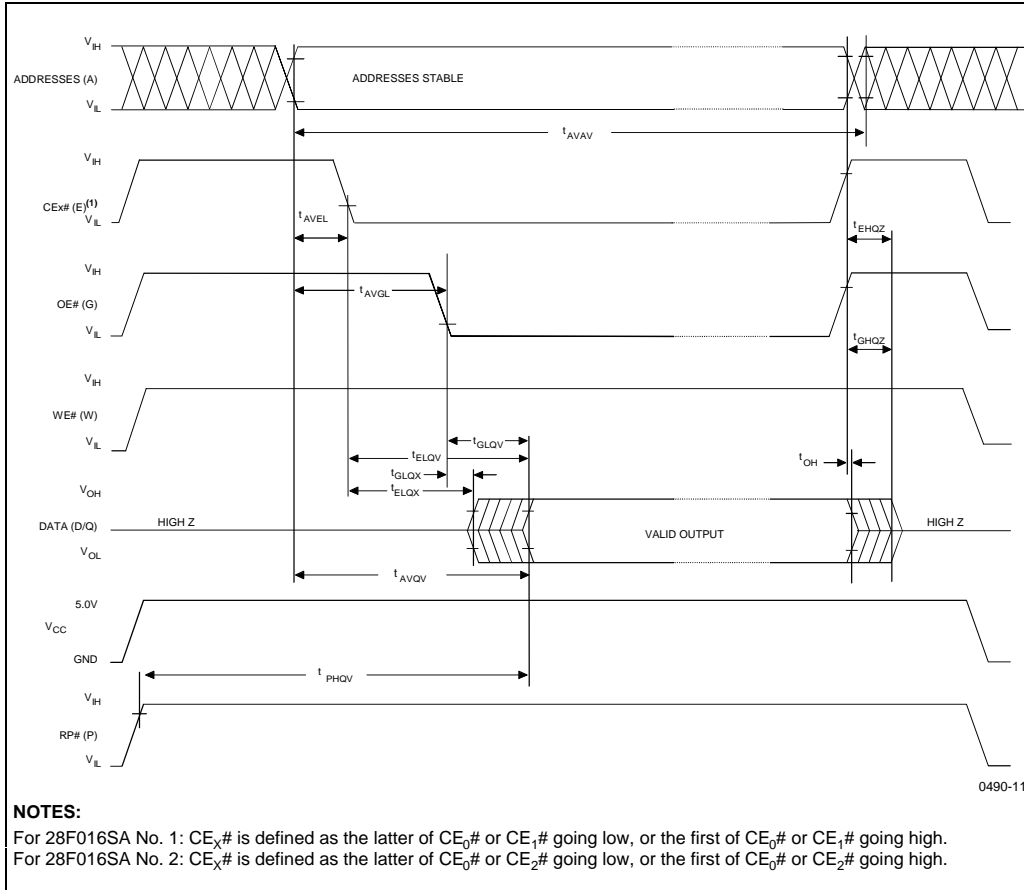

Figure 11. Read Timing Waveforms



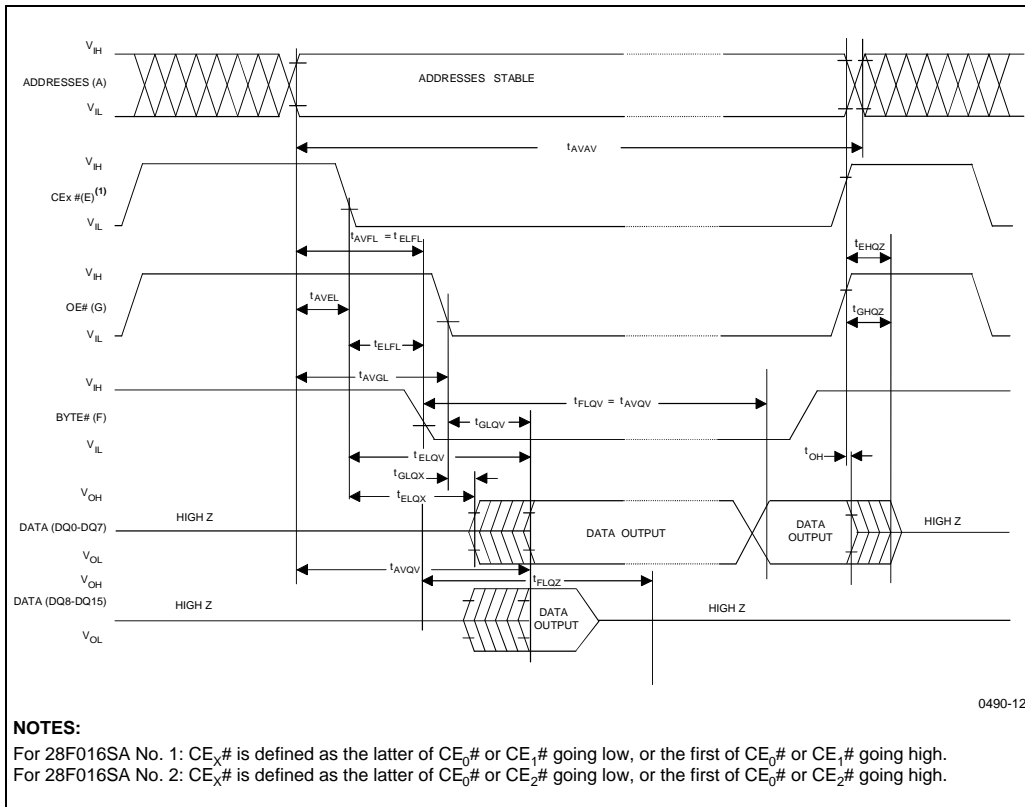

Figure 12. BYTE# Timing Waveforms



6.7 Power-Up and Reset Timings

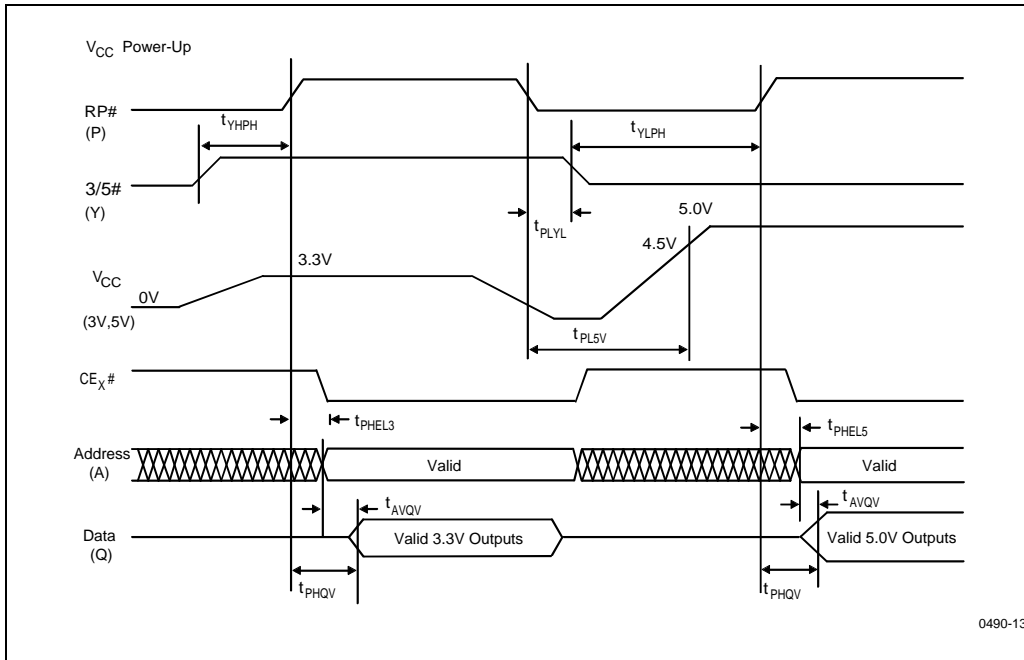

Figure 13. V_{CC} Power-Up and RP# Reset Waveforms

Symbol	Parameter	Notes	Min	Max	Units
t _{PLYL} t _{PLYH}	RP# Low to 3/5# Low (High)		0		μs
t _{YLPH} t _{YHPH}	3/5# Low (High) to RP# High	1	2		μs
t _{PL5V} t _{PL3V}	RP# Low to V _{CC} at 4.5V Minimum (to V _{CC} at 3.0V min or 3.6V max)	2	0		μs
t _{PHEL3}	RP# High to CE# Low (3.3V V _{CC})	1	500		
t _{PHEL5}	RP# High to CE# Low (5V V _{CC})	1	330		
t _{AVQV}	Address Valid to Data Valid for V _{CC} = 5.0V ± 10%	3		80	ns
t _{PHQV}	RP# High to Data Valid for V _{CC} = 5.0V ± 10%	3		480	ns

NOTES:

CE₀#, CE_x# and OE# are switched low after Power-Up.

1. The t_{YLPH}/t_{YHPH} and t_{PHEL3}/t_{PHEL5} times must be strictly followed to guarantee all other read and program specifications.
2. The power supply may start to switch concurrently with RP# going low.
3. The address access time and RP# high to data valid time are shown for the DD28F032SA-80 and 5.0V V_{CC} operation. Refer to the AC Characteristics-Read Only Operations for 3.3V V_{CC} operation and all other speed options.

6.8 AC Characteristics for WE#—Controlled Command Write Operations⁽¹⁾
 $V_{CC} = 3.3V \pm 0.3V, T_A = 0^{\circ}C \text{ to } +70^{\circ}C$

Versions			DD28F032SA-150			Unit
Symbol	Parameter	Notes	Min	Typ	Max	
t_{AVAV}	Write Cycle Time		150			ns
t_{VPWH}	V_{PP} Setup to WE# Going High	3	100			ns
t_{PHEL}	RP# Setup to CE _x # Going Low		480			ns
t_{ELWL}	CE _x # Setup to WE# Going Low		10			ns
t_{AVWH}	Address Setup to WE# Going High	2,6	75			ns
t_{DVWH}	Data Setup to WE# Going High	2,6	85			ns
t_{WLWH}	WE# Pulse Width		75			ns
t_{WHDX}	Data Hold from WE# High	2	10			ns
t_{WHAX}	Address Hold from WE# High	2	10			ns
t_{WHEH}	CE _x # Hold from WE# High		10			ns
t_{WHWL}	WE# Pulse Width High		75			ns
t_{GHWL}	Read Recovery before Write		0			ns
t_{WHRL}	WE# High to RY/BY# Going Low				100	ns
t_{RHPL}	RP# Hold from Valid Status Register (CSR, GSR, BSR) Data and RY/BY# High	3	0			ns
t_{PHWL}	RP# High Recovery to WE# Going Low		1			μs
t_{WHGL}	Write Recovery before Read		120			ns
t_{QVVL}	V_{PP} Hold from Valid Status Register (CSR, GSR, BSR) Data and RY/BY# High		0			μs
t_{WHQV1}	Duration of Word/Byte Program Operation	4,5	5	9	Note 7	μs
t_{WHQV2}	Duration of Block Erase Operation	4	0.3		10	sec

6.8 AC Characteristics for WE#—Controlled Command Write Operations⁽¹⁾

(Continued)

 $V_{CC} = 5.0V \pm 0.5V$, $5.0V \pm 0.25V$, $T_A = 0^\circ C$ to $+70^\circ C$

Versions		$V_{CC} \pm 5\%$	DD28F032SA-070									Unit
		$V_{CC} \pm 10\%$				DD28F032SA-080			DD28F032SA-100			
Sym	Parameter	Notes	Min	Typ	Max	Min	Typ	Max	Min	Typ	Max	
t_{AVAV}	Write Cycle Time		70			80			100			ns
t_{VPWH}	V_{PP} Setup to WE# Going High	3	100			100			100			ns
t_{PHEL}	RP# Setup to CE _x # Going Low		480			480			480			ns
t_{ELWL}	CE _x # Setup to WE# Going Low		0			0			0			ns
t_{AVWH}	Address Setup to WE# Going High	2,6	50			50			50			ns
t_{DVWH}	Data Setup to WE# Going High	2,6	60			60			60			ns
t_{WLWH}	WE# Pulse Width		40			50			50			ns
t_{WHDX}	Data Hold from WE# High	2	0			0			0			ns
t_{WHAX}	Address Hold from WE# High	2	10			10			10			ns
t_{WHEH}	CE _x # Hold from WE# High		10			10			10			ns
t_{WHWL}	WE# Pulse Width High		30			30			50			ns
t_{GHWL}	Read Recovery before Write		0			0			0			ns
t_{WHRL}	WE# High to RY/BY# Going Low				100			100			100	ns

6.8 AC Characteristics for WE#—Controlled Command Write Operations⁽¹⁾

(Continued)

V_{CC} = 5.0V ± 0.5V, 5.0V ± 0.25V, T_A = 0°C to +70°C

Versions		V _{CC} ± 5%	DD28F032SA-070			DD28F032SA-080			DD28F032SA-100			Unit
		V _{CC} ± 10%	Min	Typ	Max	Min	Typ	Max	Min	Typ	Max	
Sym	Parameter	Notes	Min	Typ	Max	Min	Typ	Max	Min	Typ	Max	
t _{RHPL}	RP# Hold from Valid Status Register (CSR, GSR, BSR) Data and RY/BY# High	3	0			0			0			ns
t _{PHWL}	RP# High Recovery to WE# Going Low		1			1			1			µs
t _{WHGL}	Write Recovery before Read		60			65			65			ns
t _{QVVL}	V _{PP} Hold from Valid Status Register (CSR, GSR, BSR) Data and RY/BY# High		0			0			0			µs
t _{WHQV1}	Duration of Word/Byte Program Operation	4,5	4.5	6	Note 7	4.5	6	Note 7	4.5	6	Note 7	µs
t _{WHQV2}	Duration of Block Erase Operation	4	0.3		10	0.3		10	0.3		10	sec

NOTES:

For 28F016SA No. 1: CE_x# is defined as the latter of CE₀# or CE₁# going low or the first of CE₀# or CE₁# going high.
 For 28F016SA No. 2: CE_x# is defined as the latter of CE₀# or CE₂# going low or the first of CE₀# or CE₂# going high.

1. Read timings during data program and block erase are the same as for normal read.
2. Refer to command definition tables for valid address and data values.
3. Sampled, but not 100% tested
4. Data program/block erase durations are measured to valid Status Register data.
5. Word/byte program operations are typically performed with 1 programming pulse.
6. Address and data are latched on the rising edge of WE# for all command write operations.
7. This information will be available in a technical paper. Please call Intel's Applications Hotline or your local sales office for more information.



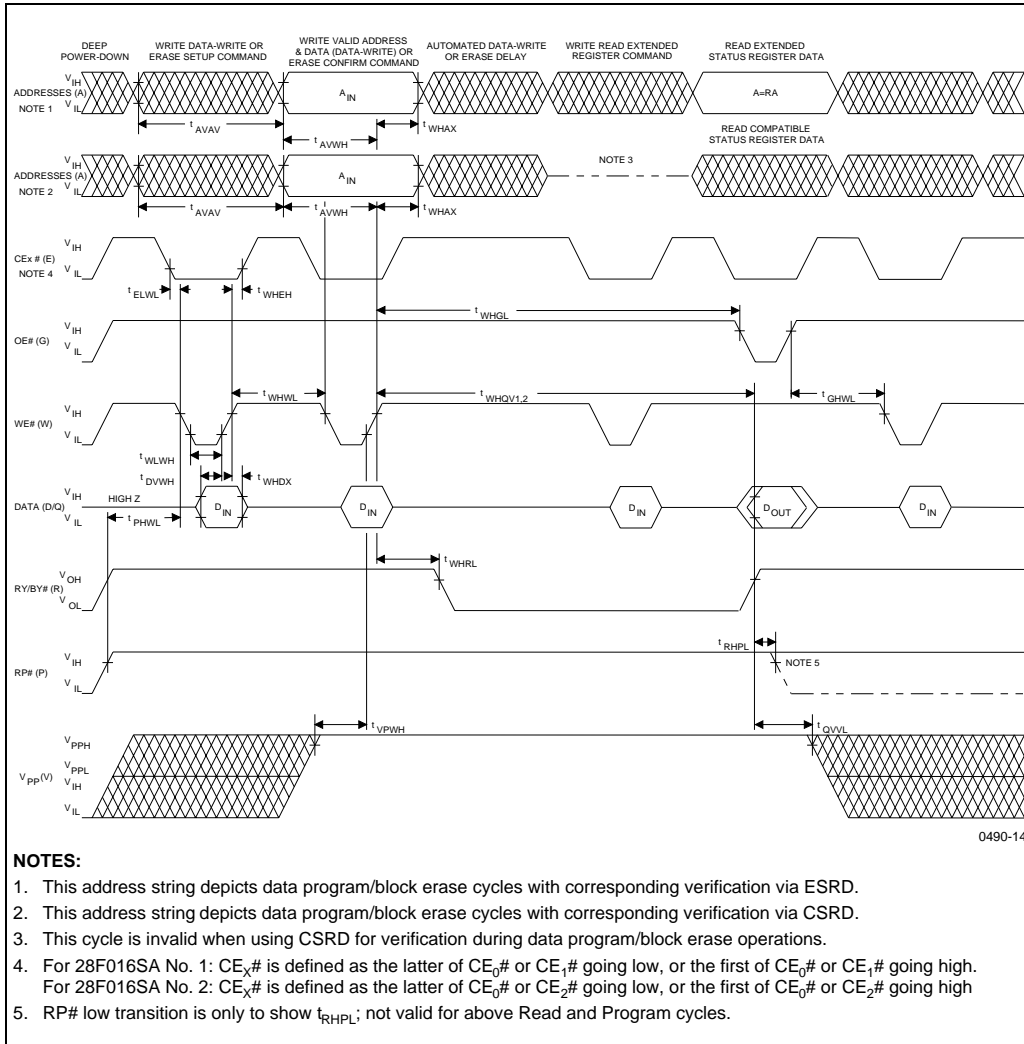

Figure 14. AC Waveforms for Command Write Operations



6.9 AC Characteristics for CE_x#—Controlled Command Write Operations⁽¹⁾
 $V_{CC} = 3.3V \pm 0.3V, T_A = 0^{\circ}C \text{ to } +70^{\circ}C$

Versions			DD28F032SA-150			Unit
Symbol	Parameter	Notes	Min	Typ	Max	
t _{AVAV}	Write Cycle Time		150			ns
t _{VPEH}	V _{PP} Setup to CE _x # Going High	3	100			ns
t _{PHWL}	RP# Setup to WE# Going Low		480			ns
t _{WLEL}	WE# Setup to CE _x # Going Low		0			ns
t _{AVEH}	Address Setup to CE _x # Going High	2,6	75			ns
t _{DVEH}	Data Setup to CE _x # Going High	2,6	85			ns
t _{ELEH}	CE _x # Pulse Width		75			ns
t _{EHDX}	Data Hold from CE _x # High	2	10			ns
t _{EHAX}	Address Hold from CE _x # High	2	10			ns
t _{EHWH}	WE# Hold from CE _x # High		10			ns
t _{EHEL}	CE _x # Pulse Width High		75			ns
t _{GHLEL}	Read Recovery before Write		0			ns
t _{EHRL}	CE _x # High to RY/BY# Going Low				100	ns
t _{RHPL}	RP# Hold from Valid Status Register (CSR, GSR, BSR) Data and RY/BY# High	3	0			ns
t _{PHLEL}	RP# High Recovery to CE _x # Going Low		1			μs
t _{EHGL}	Write Recovery before Read		120			ns
t _{QVVL}	V _{PP} Hold from Valid Status Register (CSR, GSR, BSR) Data and RY/BY# High		0			μs
t _{EHQV1}	Duration of Word/Byte Program Operation	4,5	5	9	Note 7	μs
t _{EHQV2}	Duration of Block Erase Operation	4	0.3		10	sec

6.9 AC Characteristics for CE_x#—Controlled Command Write Operations⁽¹⁾

(Continued)

V_{CC} = 5.0V ± 0.5V, 5.0V ± 0.25V, T_A = 0°C to +70°C

Versions		V _{CC} ± 5%	DD28F032SA-070									Unit
		V _{CC} ± 10%				DD28F032SA-080			DD28F032SA-100			
Sym	Parameter	Notes	Min	Typ	Max	Min	Typ	Max	Min	Typ	Max	
t _{AVAV}	Write Cycle Time		70			80			100			ns
t _{VPEH}	V _{PP} Setup to CE _x # Going High	3	100			100			100			ns
t _{PHWL}	RP# Setup to WE# Going Low	3	480			480			480			ns
t _{WLEL}	WE# Setup to CE _x # Going Low		0			0			0			ns
t _{AVEH}	Address Setup to CE _x # Going High	2,6	50			50			50			ns
t _{DVEH}	Data Setup to CE _x # Going High	2,6	60			60			60			ns
t _{ELEH}	CE _x # Pulse Width		40			50			50			ns
t _{EHDH}	Data Hold from CE _x # High	2	0			0			0			ns
t _{EHAX}	Address Hold from CE _x # High	2	10			10			10			ns
t _{EHWH}	WE# Hold from CE _x # High		10			10			10			ns
t _{EHEL}	CE _x # Pulse Width High		30			30			50			ns
t _{GHLEL}	Read Recovery before Write		0			0			0			ns
t _{EHRL}	CE _x # High to RY/BY# Going Low				100			100			100	ns
t _{RHPL}	RP# Hold from Valid Status Register (CSR, GSR, BSR) Data and RY/BY# High	3	0			0			0			ns

6.9 AC Characteristics for CE_x#—Controlled Command Write Operations⁽¹⁾

(Continued)

 $V_{CC} = 5.0V \pm 0.5V, 5.0V \pm 0.25V, T_A = 0^\circ C \text{ to } +70^\circ C$

Versions		V _{CC} ± 5%	DD28F032SA-070			DD28F032SA-080			DD28F032SA-100			Unit
		V _{CC} ± 10%	Min	Typ	Max	Min	Typ	Max	Min	Typ	Max	
Sym	Parameter	Notes	Min	Typ	Max	Min	Typ	Max	Min	Typ	Max	
t _{PHGL}	RP# High Recovery to CE _x # Going Low		1			1			1			μs
t _{EHGL}	Write Recovery before Read		60			65			80			ns
t _{QVVL}	V _{PP} Hold from Valid Status Register (CSR, GSR, BSR) Data at RY/BY# High		0			0			0			μs
t _{EHQV1}	Duration of Word/Byte Program Operation	4,5	4.5	6	Note 7	4.5	6	Note 7	4.5	6	Note 7	μs
t _{EHQV2}	Duration of Block Erase Operation	4	0.3		10	0.3		10	0.3		10	sec

NOTES:

For 28F016SA No. 1: CE_x# is defined as the latter of CE₀# or CE₁# going low or the first of CE₀# or CE₁# going high.
 For 28F016SA No. 2: CE_x# is defined as the latter of CE₀# or CE₂# going low or the first of CE₀# or CE₂# going high.

1. Read timings during data program and block erase are the same as for normal read.
2. Refer to command definition tables for valid address and data values.
3. Sampled, but not 100% tested.
4. Data program/block erase durations are measured to valid Status Register data.
5. Word/byte program operations are typically performed with 1 programming pulse.
6. Address and data are latched on the rising edge of CE_x# for all command write operations.
7. This information will be available in a technical paper. Please call Intel's Applications Hotline or your local sales office for more information.

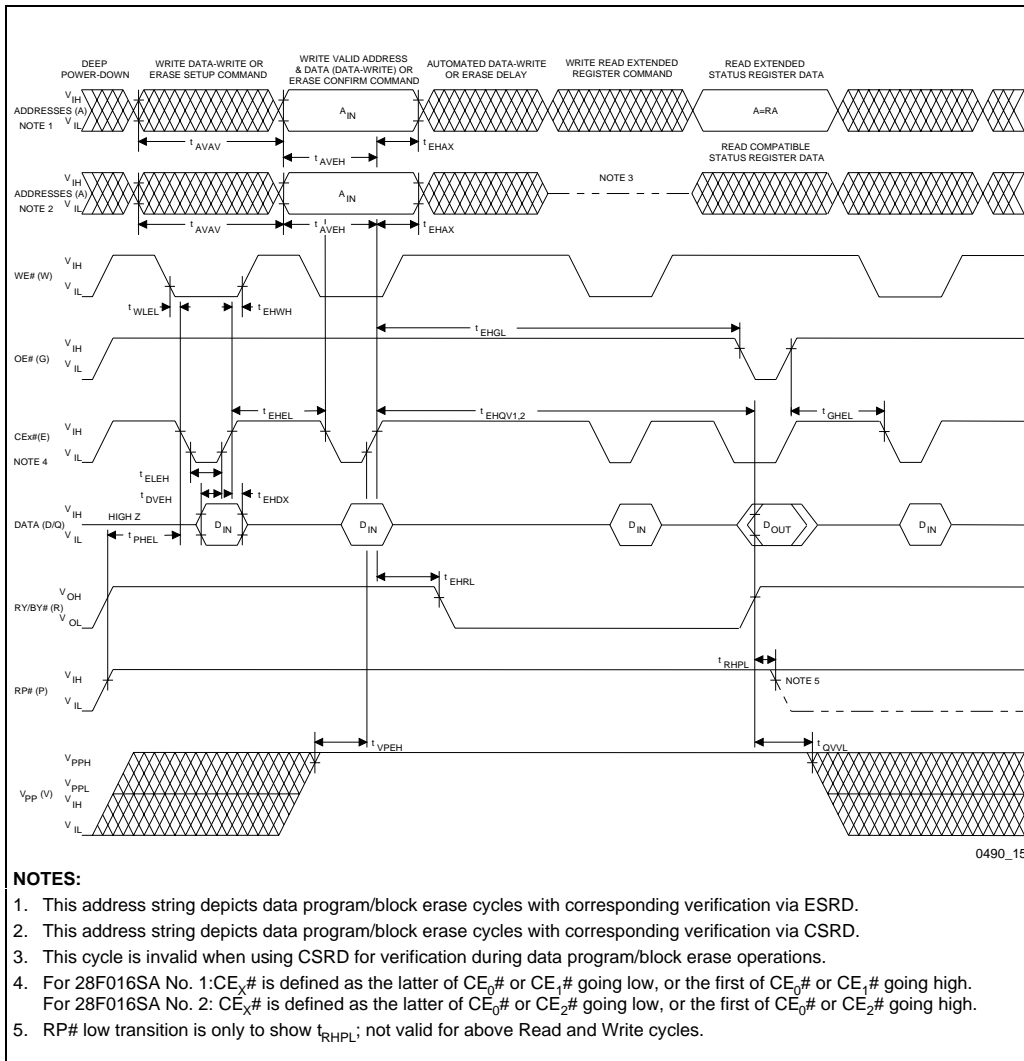

Figure 15. Alternate AC Waveforms for Command Write Operations

6.10 AC Characteristics for Page Buffer Write Operations⁽¹⁾

$V_{CC} = 3.3V \pm 0.3V$, $T_A = 0^{\circ}C$ to $+70^{\circ}C$

Versions			DD28F032SA-150			Unit
Symbol	Parameter	Notes	Min	Typ	Max	
t_{AVAV}	Write Cycle Time		150			ns
t_{ELWL}	$CE_x\#$ Setup to WE# Going Low		10			ns
t_{AVWL}	Address Setup to WE# Going Low	3	0			ns
t_{DVWH}	Data Setup to WE# Going High	2	75			ns
t_{WLWH}	WE# Pulse Width		75			ns
t_{WHDX}	Data Hold from WE# High	2	10			ns
t_{WHAX}	Address Hold from WE# High	2	10			ns
t_{WHEH}	$CE_x\#$ Hold from WE# High		10			ns
t_{WHWL}	WE# Pulse Width High		75			ns
t_{GHWL}	Read Recovery before Write		0			ns
t_{WHGL}	Write Recovery before Read		120			ns

6.10 AC Characteristics for Page Buffer Write Operations⁽¹⁾ (Continued)

$V_{CC} = 5.0V \pm 0.5V$, $5.0V \pm 0.25V$, $T_A = 0^\circ C$ to $+70^\circ C$

Versions			DD28F032SA-070			DD28F032SA-080			DD28F032SA-100			Unit
Symbol	Parameter	Notes	Min	Typ	Max	Min	Typ	Max	Min	Typ	Max	
t_{AVAV}	Write Cycle Time		70			80			100			ns
t_{ELWL}	$CE_x\#$ Setup to $WE\#$ Going Low		0			0			0			ns
t_{AVWL}	Address Setup to $WE\#$ Going Low	3	0			0			0			ns
t_{DVWH}	Data Setup to $WE\#$ Going High	2	50			50			50			ns
t_{WLWH}	$WE\#$ Pulse Width		40			50			50			ns
t_{WHDX}	Data Hold from $WE\#$ High	2	0			0			0			ns
t_{WHAX}	Address Hold from $WE\#$ High	2	10			10			10			ns
t_{WHEH}	$CE_x\#$ Hold from $WE\#$ High		10			10			10			ns
t_{WHWL}	$WE\#$ Pulse Width High		30			30			50			ns
t_{GHWL}	Read Recovery before Write		0			0			0			ns
t_{WHGL}	Write Recovery before Read		60			65			80			ns

NOTES:

For 28F016SA No. 1: $CE_x\#$ is defined as the latter of $CE_0\#$ or $CE_1\#$ going low or the first of $CE_0\#$ or $CE_1\#$ going high.
 For 28F016SA No. 2: $CE_x\#$ is defined as the latter of $CE_0\#$ or $CE_2\#$ going low or the first of $CE_0\#$ or $CE_2\#$ going high.

1. These are $WE\#$ -controlled write timings, equivalent $CE_x\#$ -controlled write timings apply.
2. Sampled, not 100% tested.
3. Address must be valid during the entire $WE\#$ low pulse or the entire $CE_x\#$ low pulse (for $CE_x\#$ -controlled write timings).



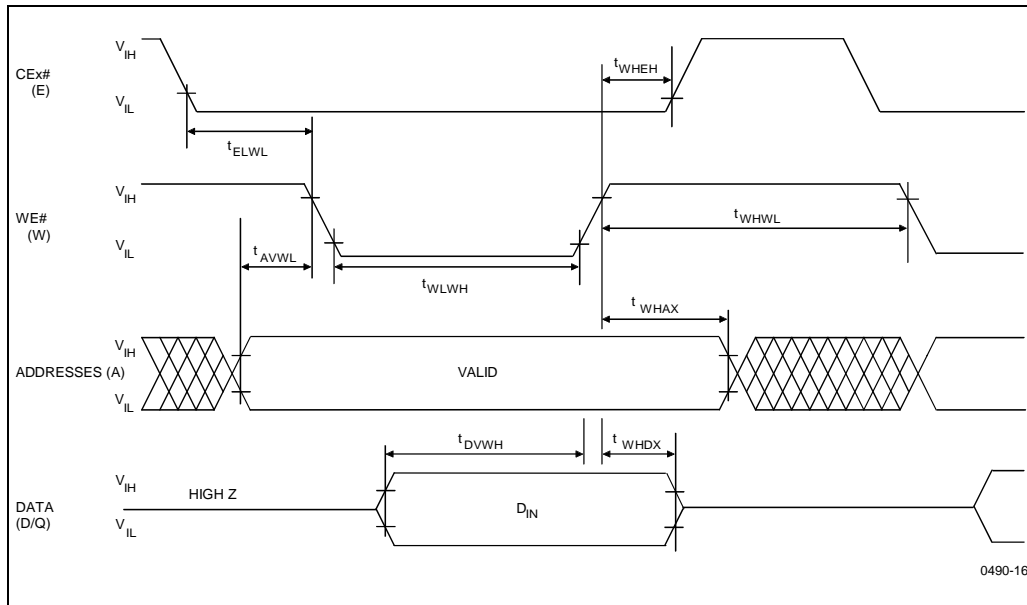

Figure 16. Page Buffer Write Timing Waveforms (Loading Data to the Page Buffer)



6.11 Erase and Word/Byte Write Performance, Cycling Performance and Suspend Latency⁽³⁾

$V_{CC} = 3.3V \pm 0.3V$, $V_{PP} = 12.0V \pm 0.6V$, $T_A = 0^\circ C$ to $+70^\circ C$

Sym	Parameter	Notes	Min	Typ ⁽¹⁾	Max	Units	Test Conditions
	Page Buffer Byte Write Time	2,4		3.26	Note 6	μs	
	Page Buffer Word Write Time	2,4		6.53	Note 6	μs	
t_{WHRH1}	Word/Byte Program Time	2		9	Note 6	μs	
t_{WHRH2}	Block Program Time	2		0.6	2.1	sec	Byte Program
t_{WHRH3}	Block Program Time	2		0.3	1.0	sec	Word Program
	Block Erase Time	2		0.8	10	sec	
	Full Chip Erase Time	2		51.2		sec	
	Erase Suspend Latency Time to Read			7.0		μs	
	Auto Erase Suspend Latency Time to Program			10.0		μs	
	Erase Cycles	5	100,000	1,000,000		Cycles	

$V_{CC} = 5.0V \pm 0.5V$, $V_{PP} = 12.0V \pm 0.6V$, $T_A = 0^\circ C$ to $+70^\circ C$

Sym	Parameter	Notes	Min	Typ ⁽¹⁾	Max	Units	Test Conditions
	Page Buffer Byte Write Time	2,4		2.76	Note 6	μs	
	Page Buffer Word Write Time	2,4		5.51	Note 6	μs	
t_{WHRH1}	Word/Byte Program Time	2		6	Note 6	μs	
t_{WHRH2}	Block Program Time	2		0.4	2.1	sec	Byte Program
t_{WHRH3}	Block Program Time	2		0.2	1.0	sec	Word Program
	Block Erase Time	2		0.6	10	sec	
	Full Chip Erase Time	2		38.4		sec	
	Erase Suspend Latency Time to Read			5.0		μs	
	Auto Erase Suspend Latency Time to Program			8.0		μs	
	Erase Cycles	5	100,000	1,000,000		Cycles	

NOTES:

- +25°C, $V_{CC} = 3.3V$ or $5.0V$ nominal, $V_{PP} = 12.0V$ nominal, 10K cycles.
- Excludes system-level overhead.
- These performance numbers are valid for all speed versions.
- This assumes using the full Page Buffer to program to the flash memory (256 bytes or 128 words).
- 1,000,000 cycle performance assumes the application uses block retirement techniques.
- This information will be available in a technical paper. Please call Intel's Application hotline or your local Intel sales office for more information.

7.0 DERATING CURVES

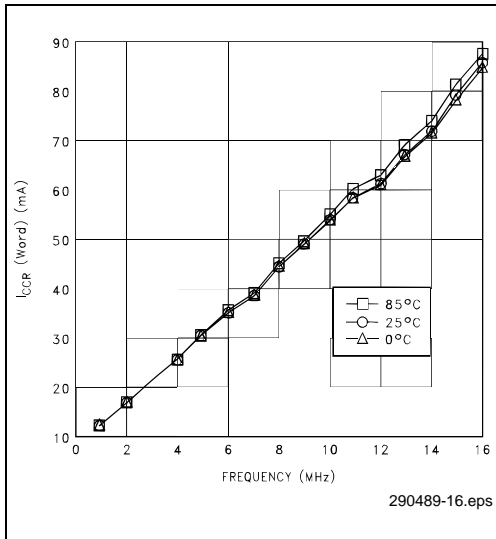

Figure 17. I_{CC} vs. Frequency (V_{CC} = 5.5V) for x8 or x16 Operation

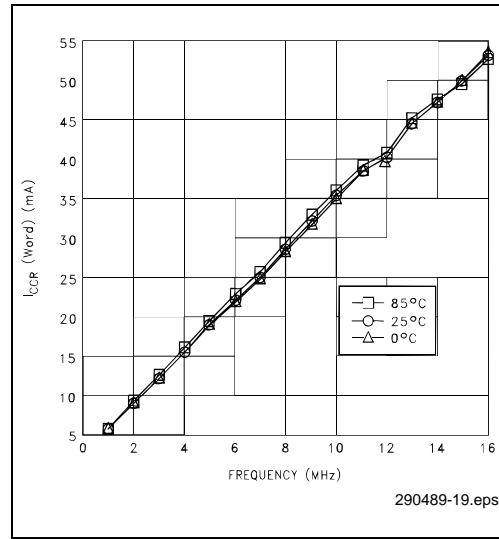

Figure 19. I_{CC} vs. Frequency (V_{CC} = 3.6V) for x8 or x16 Operation

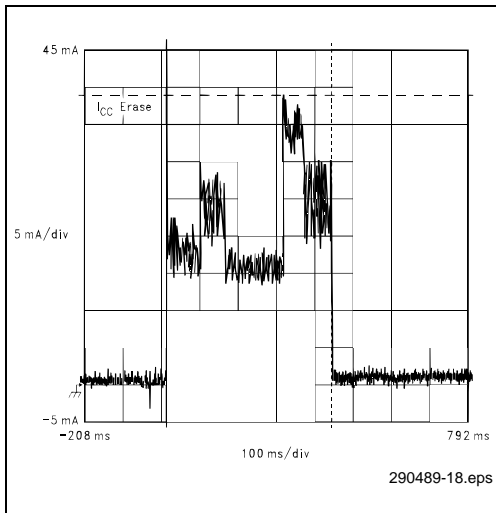

Figure 18. I_{CC} during Block Erase

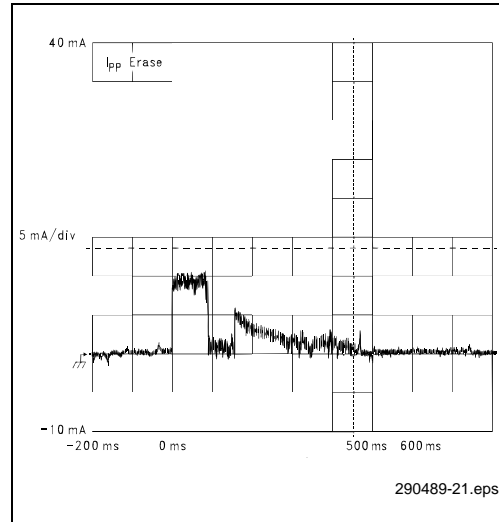

Figure 20. I_{PP} during Block Erase



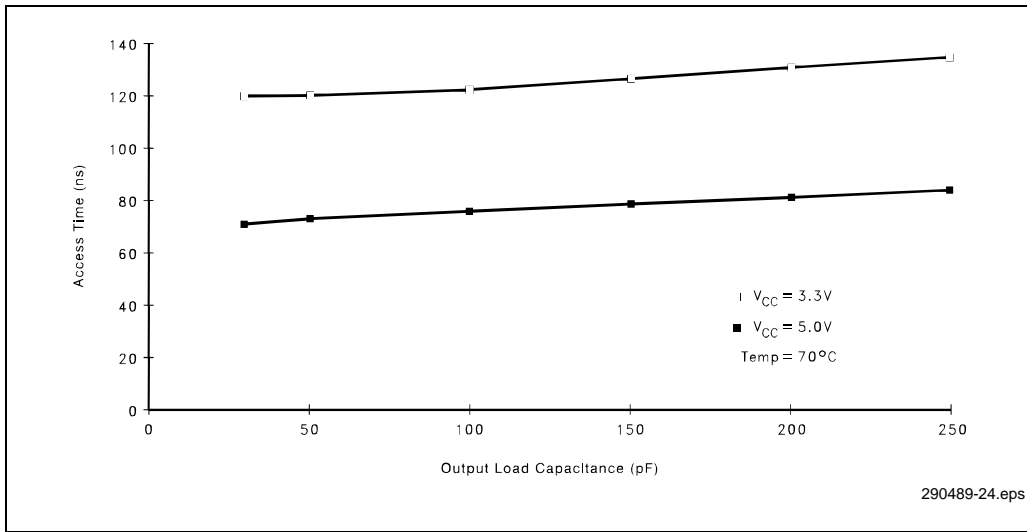

Figure 21. Access Time (t_{ACC}) vs. Output Loading

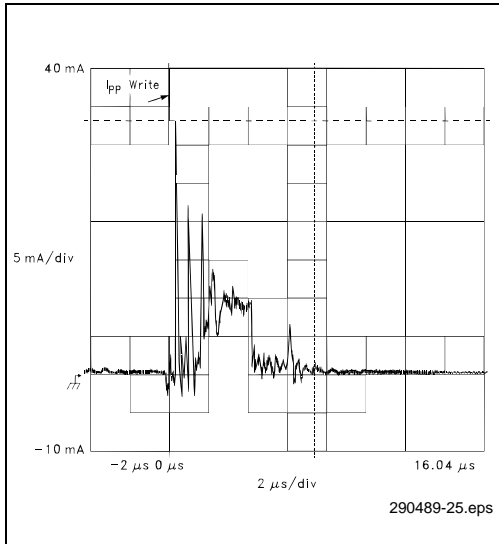

Figure 22. I_{PP} during Word Write Operation

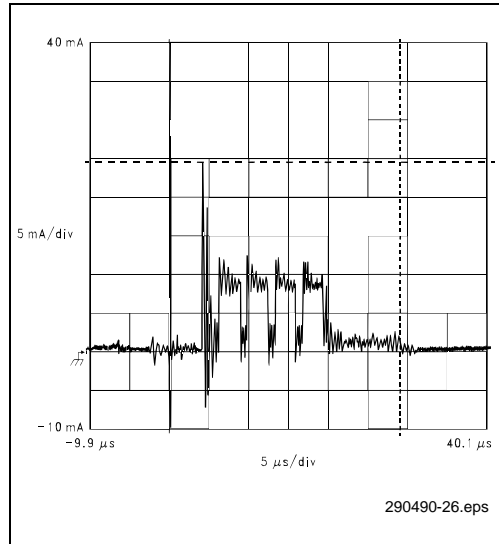
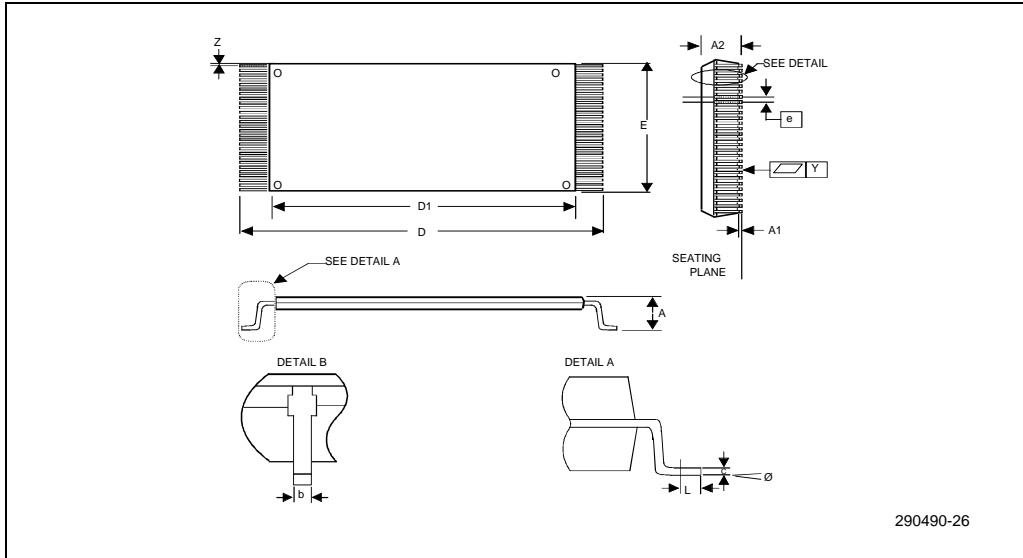

Figure 23. I_{PP} during Page Buffer Write Operation



8.0 MECHANICAL SPECIFICATIONS

Figure 24. Mechanical Specifications of the Dual Die 56-Lead TSOP Type I Package

Family: Dual Die Thin Small Out-Line Package				
Symbol	Millimeters			Notes
	Minimum	Nominal	Maximum	
A			1.20	
A1	0.05			
A2	0.965	0.995	1.025	
b	0.100	0.150	0.200	
c	0.115	0.125	0.135	
D1	18.20	18.40	18.60	
E	13.80	14.00	14.20	
e		0.50		
D	19.80	20.00	20.20	
L	0.500	0.600	0.700	
N		56		
Ø	0°	3°	5°	
Y			0.100	
Z	0.150	0.250	0.350	

APPENDIX A DEVICE NOMENCLATURE/ORDERING INFORMATION

D	D	2	8	F	0	3	2	S	A	-	0	7	0
DUAL DIE										ACCESS SPEED (ns)			
										70 ns			
										100 ns			

NOTES:
 Two valid combinations of speeds exist:
 DD28F032SA-070, DD28F032SA-080, DD28F032SA-150
 or
 DD28F032SA-100, DD28F032SA-150

Option	Order Code	Valid Combinations		
		V _{CC} = 3.3V ± 0.3V, 50 pF	V _{CC} = 5.0V ± 5%, 30 pF	V _{CC} = 5.0V ± 10%, 100 pF
1	DD28F032SA-070	DD28F032SA-150	DD28F032SA-070	DD28F032SA-080
2	DD28F032SA-100	DD28F032SA-150		DD28F032SA-100



APPENDIX B ADDITIONAL INFORMATION(1,2)

Order Number	Document/Tool
297372	<i>16-Mbit Flash Product Family User's Manual</i>
290489	<i>28F016SA 16-Mbit FlashFile™ Memory Datasheet</i>
290528	<i>28F016SV FlashFile™ Memory Datasheet</i>
290429	<i>28F008SA 8-Mbit FlashFile™ Memory Datasheet</i>
292092	<i>AP-357 Power Supply Solutions for Flash Memory</i>
292123	<i>AP-374 Flash Memory Write Protection Techniques</i>
292124	<i>AP-375 Upgrade Considerations from the 28F008SA to the 28F016SA"</i>
292126	<i>AP-377 16-Mbit Flash Product Family Software Drivers 28F016SA, 28F016SV, 28F016XS, 28F016XD</i>
292127	<i>AP-378 System Optimization Using the Enhanced Features of the 28F016SA</i>
292144	<i>AP-393 28F016SV Compatibility with 28F016SA</i>
292159	<i>AP-607 Multi-Site Layout Planning with Intel's Flash File™ Components</i>
294016	<i>ER-33 ETOX™ Flash Memory Technology– Insight to Intel's Fourth Generation Process Innovation</i>
297534	<i>Small and Low-Cost Power Supply Solutions for Intel's Flash Memory Products (Technical Paper)</i>
297508	<i>FLASHBuilder Design Resource Tool</i>

NOTES:

1. Please call the Intel Literature Center at (800) 548-4725 to request Intel documentation. International customers should contact their local Intel or distribution sales office.
2. Visit Intel's World Wide Web home page at <http://www.Intel.com> for technical documentation and tools.