

34063A

DC-TO-DC CONVERTER CONTROL CIRCUITS

The 34063A is a monolithic control circuit containing the primary functions required for DC-to-DC converters. These devices consist of an internal temperature compensated reference, comparator, controlled duty cycle oscillator with an active current limit circuit, driver and high current output switch. This series was specifically designed to be incorporated in Step-Down and Step-Up and Voltage-Inverting applications with a minimum number of external components.

FEATURES

- Operation from 3.0 V to 40 V Input
- Low Standby Current
- Current Limiting
- Output Switch Current to 1.5 A
- Output Voltage Adjustable
- Frequency Operation to 100 kHz
- Precision 2% Reference

FUNCTIONAL BLOCK DIAGRAM

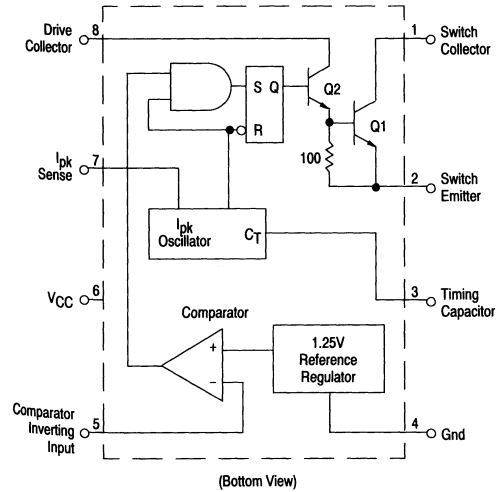

MAXIMUM RATINGS

Rating	Symbol	Value	Unit
Power Supply Voltage	V_{CC}	40	Vdc
Comparator Input Voltage Range	V_{IR}	-0.3 to +40	Vdc
Switch Collector Voltage	$V_{C(\text{switch})}$	40	Vdc
Switch Emitter Voltage (Vpin 1 = 40 V)	$V_{E(\text{switch})}$	40	Vdc
Switch Collector to Emitter Voltage	$V_{CE(\text{switch})}$	40	Vdc
Driver Collector Voltage	$V_{C(\text{driver})}$	40	Vdc
Driver Collector Current (Note 1)	$I_{C(\text{driver})}$	100	mA
Switch Current	I_{SW}	1.5	A
Power Dissipation and Thermal Characteristics			
Ceramic Package, U Suffix $T_A = +25^\circ\text{C}$	P_D	1.25	W
Thermal Resistance	$R_{\theta JA}$	100	$^\circ\text{C}/\text{W}$
Plastic Package, P Suffix $T_A = +25^\circ\text{C}$	P_D	1.25	W
Thermal Resistance	$R_{\theta JA}$	100	$^\circ\text{C}/\text{W}$
SOIC Package, D Suffix $T_A = +25^\circ\text{C}$	P_D	625	mW
Thermal Resistance	$R_{\theta JA}$	160	$^\circ\text{C}/\text{W}$
Operating Junction Temperature	T_J	+150	$^\circ\text{C}$
Operating Ambient Temperature Range	T_A	0 to +70	$^\circ\text{C}$
Storage Temperature Range	T_{stg}	-65to+150	$^\circ\text{C}$

ORDERING INFORMATION

Device	Temperature Range	Package
34063AD	0° to +70°C	SO-8
34063AP1		Plastic DIP

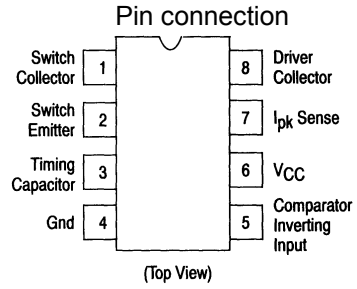

ELECTRICAL CHARACTERISTICS

(V_{CC} = 5.0 V, T_A = 0 to +70°C unless otherwise specified.)

Characteristics	Symbol	Min	Typ	Max	Unit
OSCILLATOR					
Frequency (V _{Pin5} = 0 V, C _T = 1.0 nF, T _A = 25°C)	f _{osc}	24	33	42	kHz
Charge Current (V _{CC} = 5.0 V to 40 V, T _A = 25°C)	I _{chg}	24	33	42	μA
Discharge Current (V _{CC} = 5.0 V to 40 V, T _A = 25°C)	I _{dischg}	140	200	260	μA
Discharge to Charge Current Ratio (Pin7 to V _{CC} , T _A = 25°C)	I _{dischg} /I _{chg}	5.2	6.2	7.5	—
Current Limit Sense Voltage (I _{chg} = I _{dischg} , T _A = 25°C)	V _{ipk(sense)}	250	300	350	mV
OUTPUT SWITCH (Note 3)					
Saturation Voltage, Darlington Connection (I _{SW} = 1.0 A, Pins 1, 8 connected)	V _{CE(sat)}	—	1.0	1.3	V
Saturation Voltage (I _{SW} = 1.0 A, R _{Pin8} = 82 Ω to V _{CC} . Forced β = 20)	V _{CE(sat)}	—	0.45	0.7	V
DC Current Gain (I _{SW} = 1.0 A, V _{CE} = 5.0 V, T _A = 25°C)	h _{FE}	50	120	—	—
Collector Off-State Current (V _{CE} = 40V)	I _{C(off)}	—	0.01	100	μA
COMPARATOR					
Threshold Voltage (T _A = 25°C) (T _A = T _{LOW} to T _{HIGH})	V _{th}	1.225 1.21	1.25 —	1.275 1.29	V
Threshold Voltage (T_A = 25°C) **	V_{th}	1.2375	1.25	1.2625	V
Threshold Voltage Line Regulation (V _{CC} = 3.0 V to 40 V)	V _{REG line}		1.4	5.0	mV
Input Bias Current (V _{in} = 0V)	I _{IB}	—	-40	-400	nA
TOTAL DEVICE					
Supply Current (V _{CC} = 5.0 V to 40 V, C _T = 1.0 nF, V _{pin7} = V _{CC} . V _{Pin5} > V _{th} , Pin 2 = Gnd, Remaining pins open)	I _{CC}		2.5	4.0	mA

NOTES:

- Maximum package power dissipation limits must be observed.
- Low duty cycle pulse techniques are used during test to maintain Junction temperature as close to ambient temperature as possible
- If the output switch is driven into hard saturation (non Darlington configuration) at low switch currents (< 300 mA) and high driver currents (>30 mA), it may take up to 2.0 μs to come out of saturation. This condition will shorten the off time at frequencies > 30 kHz, and is magnified at high temperatures. This condition does not occur with a Darlington configuration, since the output switch cannot saturate. If a non Darlington configuration is used, the following output drive condition is recommended:

Forced β of output switch = I_C, output / (I_C, driver - 7.0 mA*) > 10

*The 100 Ω resistor in the emitter of the driver device requires about 7.0 mA before the output switch conducts

**Possible version for shipment