

### Features

- **Maximum Acquisition Time**
  - 10V Step to 0.1%..... 4μs (Max)
  - 10V Step to 0.01%..... 6μs (Max)
- **Low Droop Rate (C<sub>H</sub> = 1000pF)..... 5μV/ms (Typ)**
- **Gain Bandwidth Product ..... 2.5MHz (Typ)**
- **Low Effective Aperture Delay Time ..... 30ns (Typ)**
- **TTL Compatible Control Input**
- **±12V to ±15V Operation**

### Applications

- **12-Bit Data Acquisition**
- **Digital to Analog Deglitcher**
- **Auto Zero Systems**
- **Peak Detector**
- **Gated Operational Amplifier**

### Ordering Information

PART NUMBER	TEMP. RANGE (°C)	PACKAGE	PKG. NO.
HA1-2420-2	-55 to 125	14 Ld CERDIP	F14.3
HA1-2425-5	0 to 75	14 Ld CERDIP	F14.3
HA3-2425-5	0 to 75	14 Ld PDIP	E14.3
HA4P2425-5	0 to 75	20 Ld PLCC	N20.35
HA9P2425-5	0 to 75	14 Ld SOIC	M14.15

### Description

The HA-2420 and HA-2425 is a monolithic circuit consisting of a high performance operational amplifier with its output in series with an ultra-low leakage analog switch and JFET input unity gain amplifier.

With an external hold capacitor connected to the switch output, a versatile, high performance sample-and-hold or track-and-hold circuit is formed. When the switch is closed, the device behaves as an operational amplifier, and any of the standard op amp feedback networks may be connected around the device to control gain, frequency response, etc. When the switch is opened the output will remain at its last level.

Performance as a sample-and-hold compares very favorably with other monolithic, hybrid, modular, and discrete circuits. Accuracy to better than 0.01% is achievable over the temperature range. Fast acquisition is coupled with superior droop characteristics, even at high temperatures. High slew rate, wide bandwidth, and low acquisition time produce excellent dynamic characteristics. The ability to operate at gains greater than 1 frequently eliminates the need for external scaling amplifiers.

The device may also be used as a versatile operational amplifier with a gated output for applications such as analog switches, peak holding circuits, etc. For more information, please see Application Note AN517.

The MIL-STD-883 data sheet for this device is available on request.

### Pinouts

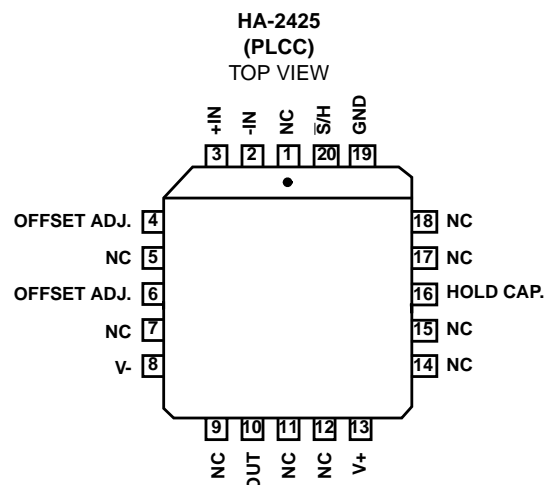
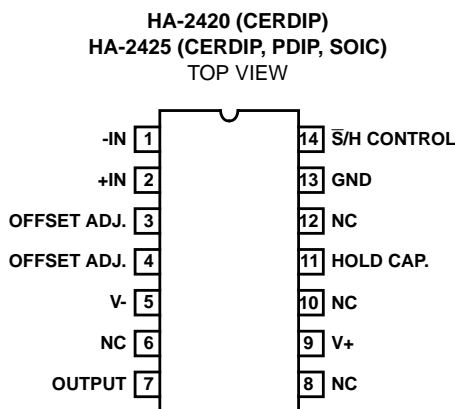

## HA-2420, HA-2425

### Absolute Maximum Ratings

Voltage Between V+ and V- Terminals	40V
Differential Input Voltage	24V
Digital Input Voltage (Sample and Hold Pin)	+8V, -15V
Output Current	Short Circuit Protected

### Operating Conditions

Temperature Range	
HA-2420-2	-55°C to 125°C
HA-2425-5	0°C to 75°C
Supply Voltage Range (Typical)	±12V to ±15V

### Thermal Information

Thermal Resistance (Typical, Note 1)	$\theta_{JA}$ (°C/W)	$\theta_{JC}$ (°C/W)
CERDIP Package	90	35
PDIP Package	100	N/A
PLCC Package	75	N/A
SOIC Package	120	N/A
Maximum Junction Temperature (Ceramic Packages)	175°C	
Maximum Junction Temperature (Plastic Package)	150°C	
Maximum Storage Temperature Range	-65°C to 150°C	
Maximum Lead Temperature (Soldering 10s)	300°C (PLCC and SOIC - Lead Tips Only)	

**CAUTION:** Stresses above those listed in "Absolute Maximum Ratings" may cause permanent damage to the device. This is a stress only rating and operation of the device at these or any other conditions above those indicated in the operational sections of this specification is not implied.

#### NOTE:

- $\theta_{JA}$  is measured with the component mounted on an evaluation PC board in free air.

**Electrical Specifications** Test Conditions (Unless Otherwise Specified)  $V_{SUPPLY} = \pm 15.0V$ ;  $C_H = 1000pF$ ; Digital Input:  $V_{IL} = +0.8V$  (Sample),  $V_{IH} = +2.0V$  (Hold), Unity Gain Configuration (Output tied to Negative Input)

PARAMETER	TEST CONDITIONS	TEMP. (°C)	HA-2420-2			HA-2425-5			UNITS
			MIN	TYP	MAX	MIN	TYP	MAX	
<b>INPUT CHARACTERISTICS</b>									
Input Voltage Range		Full	±10	-	-	±10	-	-	V
Offset Voltage		25	-	2	4	-	3	6	mV
		Full	-	3	6	-	4	8	mV
Bias Current		25	-	40	200	-	40	200	nA
		Full	-	-	400	-	-	400	nA
Offset Current		25	-	10	50	-	10	50	nA
		Full	-	-	100	-	-	100	nA
Input Resistance		25	5	10	-	5	10	-	MΩ
Common Mode Range		Full	±10	-	-	±10	-	-	V
<b>TRANSFER CHARACTERISTICS</b>									
Large Signal Voltage Gain	$R_L = 2k\Omega$ , $V_O = 20V_{P-P}$	Full	25	50	-	25	50	-	kV/V
Common Mode Rejection	$V_{CM} = \pm 10V$	Full	80	90	-	74	90	-	dB
Hold Mode Feedthrough Attenuation (Note 2)	$f_{IN} \leq 100kHz$	Full	-	-76	-	-	-76	-	dB
Gain Bandwidth Product (Note 2)		25	-	2.5	-	-	2.5	-	MHz
<b>OUTPUT CHARACTERISTICS</b>									
Output Voltage Swing	$R_L = 2k\Omega$	Full	±10	-	-	±10	-	-	V
Output Current		25	±15	-	-	±15	-	-	mA
Full Power Bandwidth (Note 2)	$V_O = 20V_{P-P}$	25	-	100	-	-	100	-	kHz
Output Resistance	DC	25	-	0.15	-	-	0.15	-	Ω
<b>TRANSIENT RESPONSE</b>									
Rise Time (Note 2)	$V_O = 200mV_{P-P}$	25	-	75	100	-	75	100	ns
Overshoot (Note 2)	$V_O = 200mV_{P-P}$	25	-	25	40	-	25	40	%
Slew Rate (Note 2)	$V_O = 10V_{P-P}$	25	3.5	5	-	3.5	5	-	V/μs
<b>DIGITAL INPUT CHARACTERISTICS</b>									
Digital Input Current	$V_{IN} = 0V$	Full	-	-	-0.8	-	-	-0.8	mA
	$V_{IN} = 5V$	Full	-	-	20	-	-	20	μA
Digital Input Voltage	Low	Full	-	-	0.8	-	-	0.8	V
	High	Full	2.0	-	-	2.0	-	-	V
<b>SAMPLE AND HOLD CHARACTERISTICS</b>									
Acquisition Time (Note 2)	To 0.1% 10V Step	25	-	2.3	4	-	2.3	4	μs

## HA-2420, HA-2425

**Electrical Specifications** Test Conditions (Unless Otherwise Specified)  $V_{SUPPLY} = \pm 15.0V$ ;  $C_H = 1000pF$ ; Digital Input:  $V_{IL} = +0.8V$  (Sample),  $V_{IH} = +2.0V$  (Hold), Unity Gain Configuration (Output tied to Negative Input) **(Continued)**

PARAMETER	TEST CONDITIONS	TEMP. (°C)	HA-2420-2			HA-2425-5			UNITS
			MIN	TYP	MAX	MIN	TYP	MAX	
Acquisition Time (Note 2)	To 0.01% 10V Step	25	-	3.2	6	-	3.2	6	$\mu s$
Hold Step Error	$V_{IN} = 0V$	25	-	10	20	-	10	20	mV
Hold Mode Settling Time	To $\pm 1mV$	25	-	860	-	-	860	-	ns
Aperture Time (Note 3)		25	-	30	-	-	30	-	ns
Effective Aperture Delay Time		25	-	30	-	-	30	-	ns
Aperture Uncertainty		25	-	5	-	-	5	-	ns
Drift Current (Note 2)	$V_{IN} = 0V$	25	-	5	-	-	5	-	$\mu A$
HA1-2420		Full	-	1.8	10	-	-	-	nA
HA1-2425		Full	-	-	-	-	0.1	1.0	nA
HA3-2425, HA4P2425, HA9P2425		Full	-	-	-	-	7.5	10.0	nA

POWER SUPPLY CHARACTERISTICS									
Supply Current (+)		25	-	3.5	5.5	-	3.5	5.5	mA
Supply Current (-)		25	-	2.5	3.5	-	2.5	3.5	mA
Power Supply Rejection		Full	80	90	-	74	90	-	dB

- NOTES:
- $A_V = \pm 1$ ,  $R_L = 2k\Omega$ ,  $C_L = 50pF$ .
  - Derived from computer simulation only; not tested.

### Functional Diagram

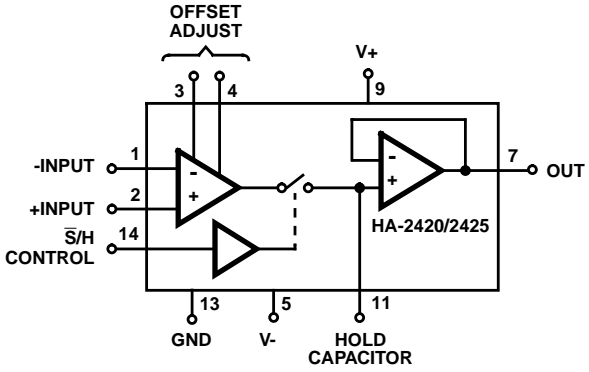

### Test Circuits and Waveforms

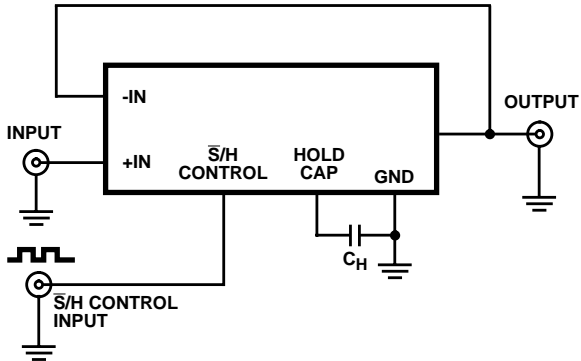
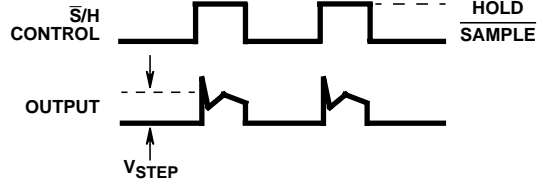

FIGURE 1. HOLD STEP ERROR AND DRIFT CURRENT



NOTE: Set rise/fall times of  $\bar{S}/H$  Control to approximately 20ns.

FIGURE 2. HOLD STEP ERROR TEST

## HA-2420, HA-2425

### Test Circuits and Waveforms (Continued)

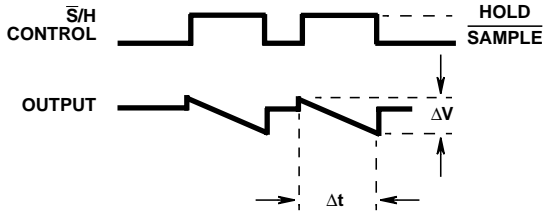

NOTE: Measure the slope of the output during hold,  $\Delta V/\Delta t$ , and compute drift current from:  $I_D = C_H \Delta V/\Delta t$ .

FIGURE 3. DRIFT CURRENT TEST

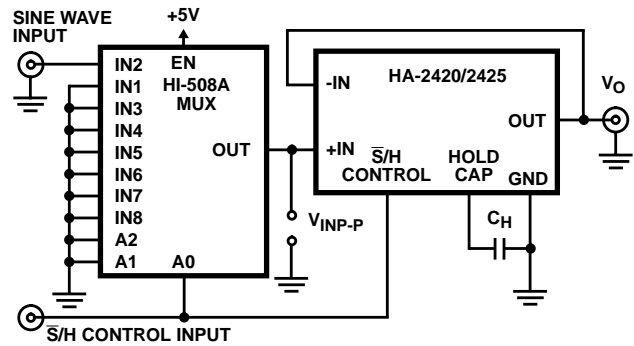

NOTE: Compute hold mode feedthrough attenuation from the formula:

$$\text{Feedthrough Attenuation} = 20 \log \frac{V_{\text{OUT HOLD}}}{V_{\text{IN HOLD}}}$$

Where  $V_{\text{OUT HOLD}}$  = Peak-to-Peak value of output sinewave during the hold mode.

FIGURE 4. HOLD MODE FEEDTHROUGH ATTENUATION

### Schematic Diagram

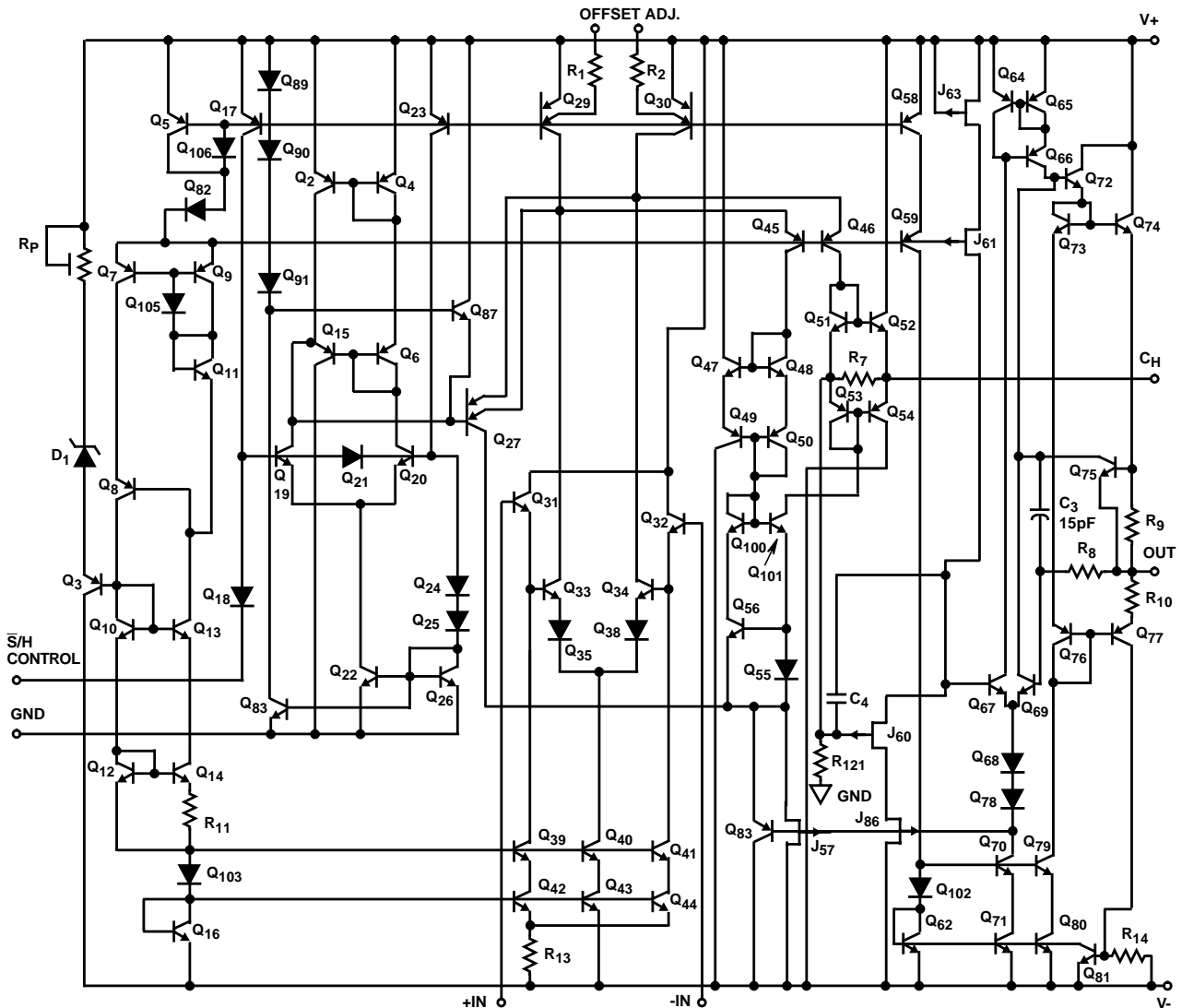

**Application Information**

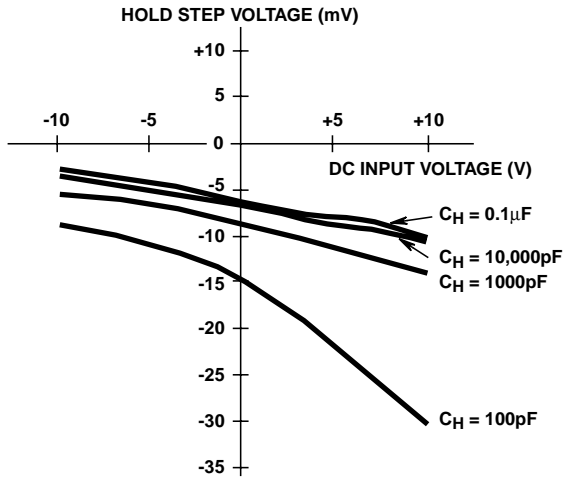

FIGURE 5. HOLD STEP vs INPUT VOLTAGE

**Offset Adjustment**

The offset voltage of the HA-2420 and HA-2425 may be adjusted using a 100kΩ trim pot, as shown in Figure 8. The recommended adjustment procedure is:

Apply 0V to the sample-and-hold input, and a square wave to the  $\bar{S}/H$  control.

Adjust the trim pot for 0V output in the hold mode.

**Gain Adjustment**

The linear variation in pedestal voltage with sample-and-hold input voltage causes a -0.06% gain error ( $C_H = 1000pF$ ). In some applications (D/A deglitcher, A/D converter) the gain error can be adjusted elsewhere in the system, while in other applications it must be adjusted at the sample-and-hold. The two circuits shown below demonstrate how to adjust gain error at the sample-and-hold.

The recommended procedure for adjusting gain error is:

1. Perform offset adjustment.
2. Apply the nominal input voltage that should produce a +10V output.
3. Adjust the trim pot for +10V output in the hold mode.
4. Apply the nominal input voltage that should produce a -10V output.
5. Measure the output hold voltage ( $V_{-10NOMINAL}$ ). Adjust the trim pot for an output hold voltage of

$$\frac{(V_{-10NOMINAL}) + (-10V)}{2}$$

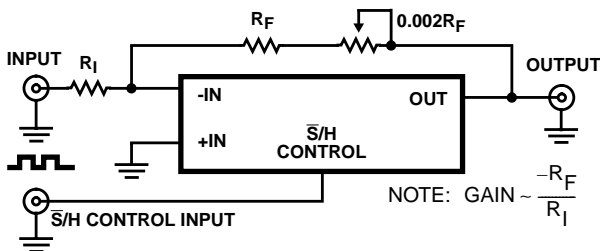

FIGURE 6. INVERTING CONFIGURATION

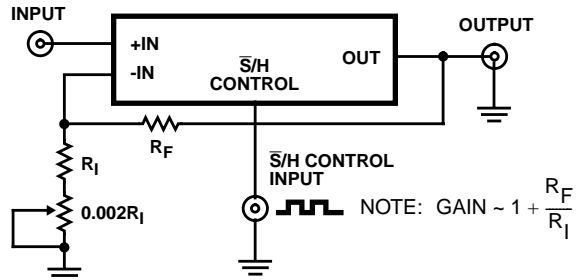

FIGURE 7. NON-INVERTING CONFIGURATION

Figure 8 shows a typical unity gain circuit, with Offset Zeroing. All of the other normal op amp feedback configurations may be used with the HA-2420/2425. The input amplifier may be used as a gated amplifier by utilizing Pin 11 as the output. This amplifier has excellent drive capabilities along with exceptionally low switch leakage.

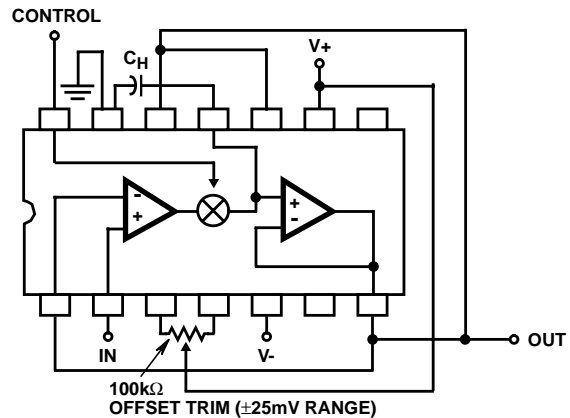

FIGURE 8. BASIC SAMPLE-AND-HOLD (TOP VIEW)

The method used to reduce leakage paths on the PC board and the device package is shown in Figure 9. This guard ring is recommended to minimize the drift during hold mode.

The hold capacitor should have extremely high insulation resistance and low dielectric absorption. Polystyrene (below 85°C), Teflon, or Parlene types are recommended.

For more applications, consult Intersil Application Note AN517, or the factory applications group.

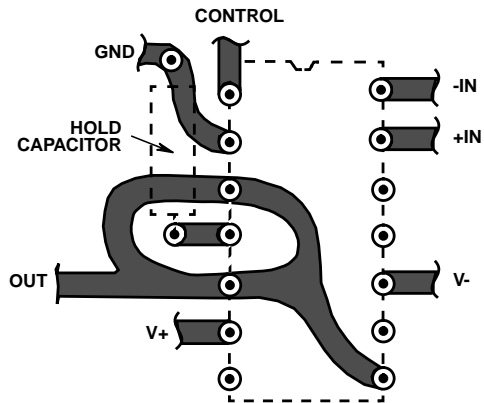

FIGURE 9. GUARD RING LAYOUT (BOTTOM VIEW)

## Glossary of Terms

### Acquisition Time

The time required following a "sample" command, for the output to reach its final value within  $\pm 0.1\%$  or  $\pm 0.01\%$ . This is the minimum sample time required to obtain a given accuracy, and includes switch delay time, slewing time and settling time.

### Aperture Time

The time required for the sample-and-hold switch to open, independent of delays through the switch driver and input amplifier circuitry. The switch opening time is that interval between the conditions of 10% open and 90% open.

### Effective Aperture Delay Time (EADT)

The difference between the digital delay time from the Hold command to the opening of the S/H switch, and the propagation time from the analog input to the switch.

EADT may be positive, negative or zero. If zero, the S/H amplifier will output a voltage equal to  $V_{IN}$  at the instant the Hold command was received. For negative EADT, the output in Hold (exclusive of pedestal and droop errors) will correspond to a value of  $V_{IN}$  that occurred before the Hold command.

### Aperture Uncertainty

The range of variation in Effective Aperture Delay Time. Aperture Uncertainty (also called Aperture Delay Uncertainty, Aperture Time Jitter, etc.) sets a limit on the accuracy with which a waveform can be reconstructed from sample data.

### Drift Current

The net leakage current from the hold capacitor during the hold mode. Drift current can be calculated from the droop rate using the formula:

$$I_D \text{ (pA)} = C_H \text{ (pF)} \times \frac{\Delta V}{\Delta t} \text{ (V/s)}$$

## Typical Performance Curves

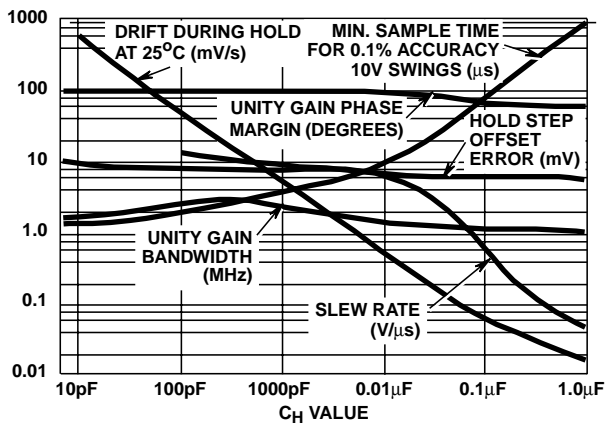

FIGURE 10. TYPICAL SAMPLE AND HOLD PERFORMANCE AS A FUNCTION OF HOLDING CAPACITOR

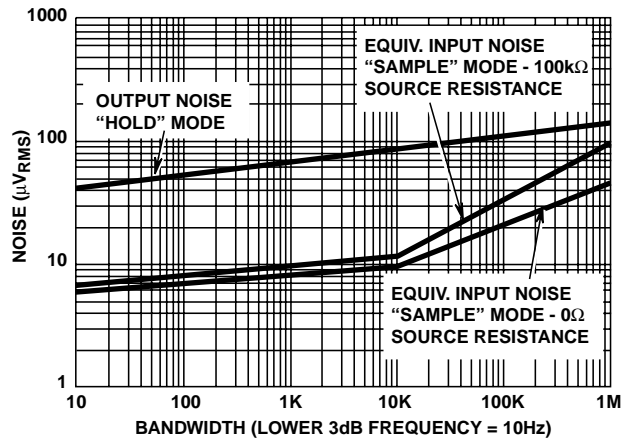

FIGURE 11. BROADBAND NOISE CHARACTERISTICS

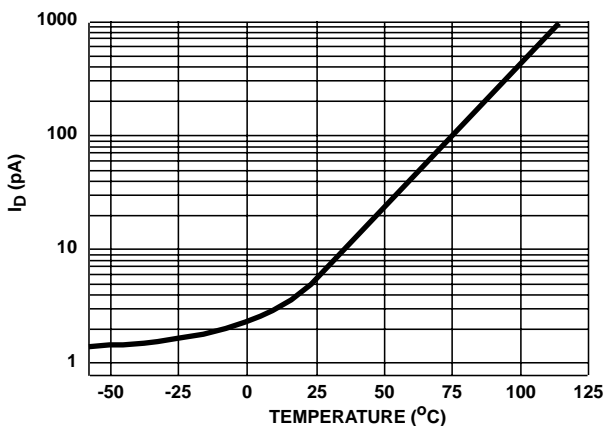

FIGURE 12. DRIFT CURRENT vs TEMPERATURE

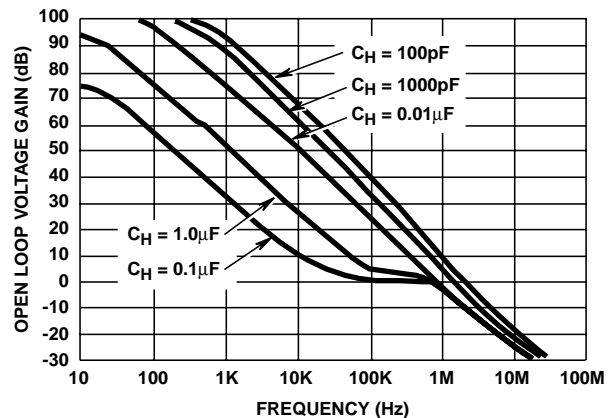

FIGURE 13. OPEN LOOP FREQUENCY RESPONSE

Typical Performance Curves (Continued)

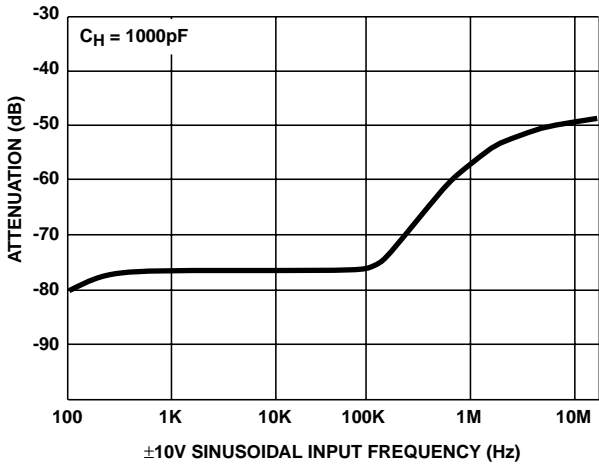

FIGURE 14. HOLD MODE FEED THROUGH ATTENUATION

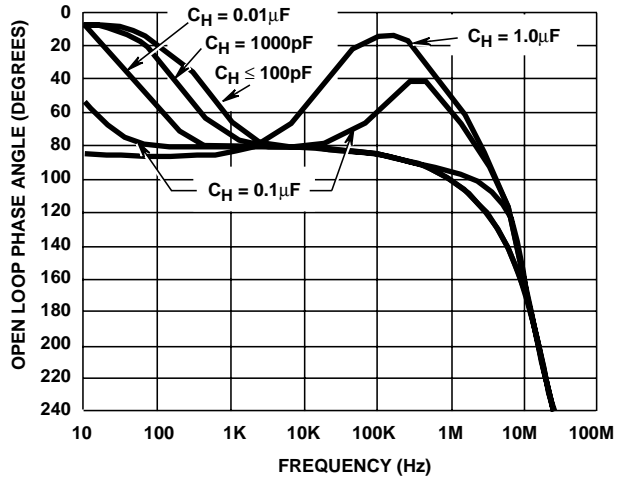

FIGURE 15. OPEN LOOP PHASE RESPONSE

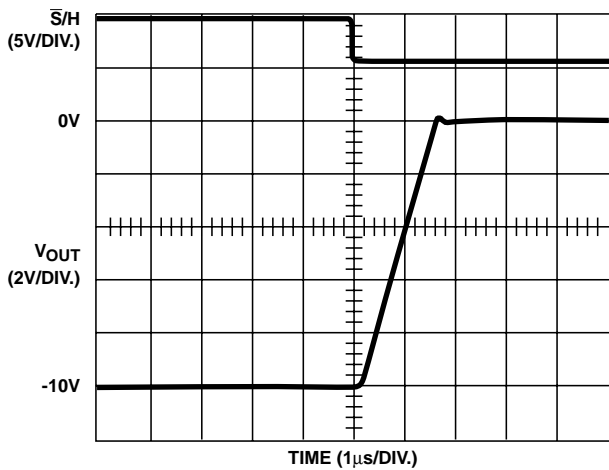

FIGURE 16. ACQUISITION TIME ( $C_H = 1000\text{pF}$ )

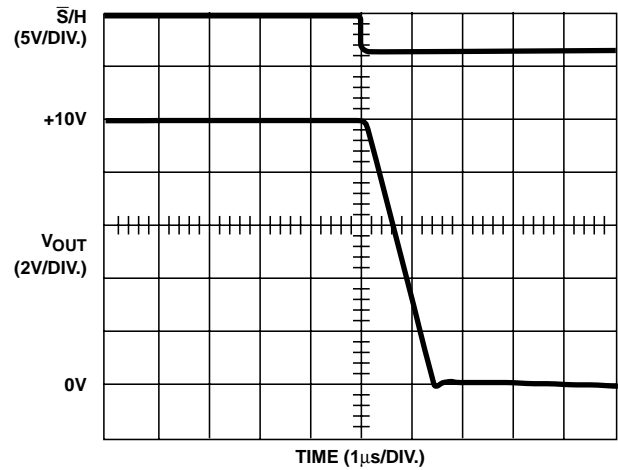

FIGURE 17. ACQUISITION TIME ( $C_H = 1000\text{pF}$ )

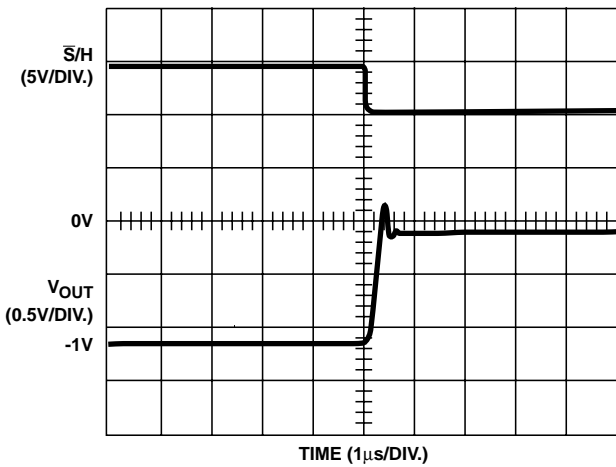

FIGURE 18. ACQUISITION TIME ( $C_H = 1000\text{pF}$ )

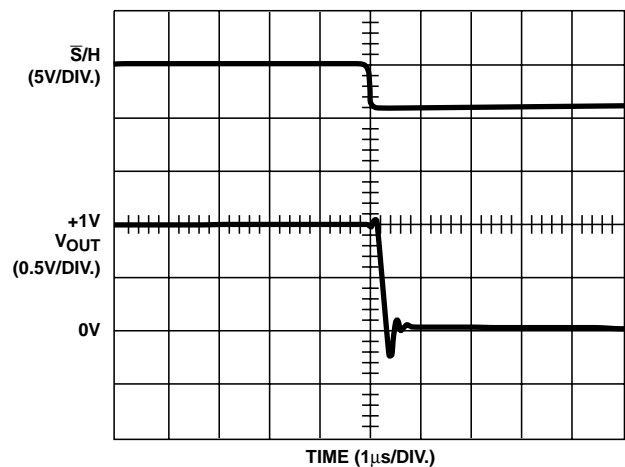

FIGURE 19. ACQUISITION TIME ( $C_H = 1000\text{pF}$ )

Typical Performance Curves (Continued)

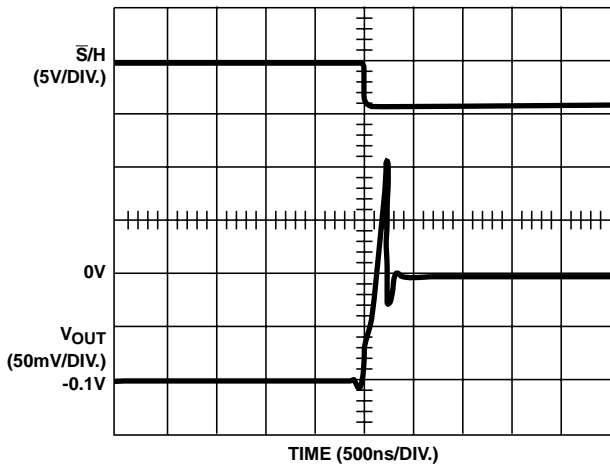

FIGURE 20. ACQUISITION TIME ( $C_H = 1000\text{pF}$ )

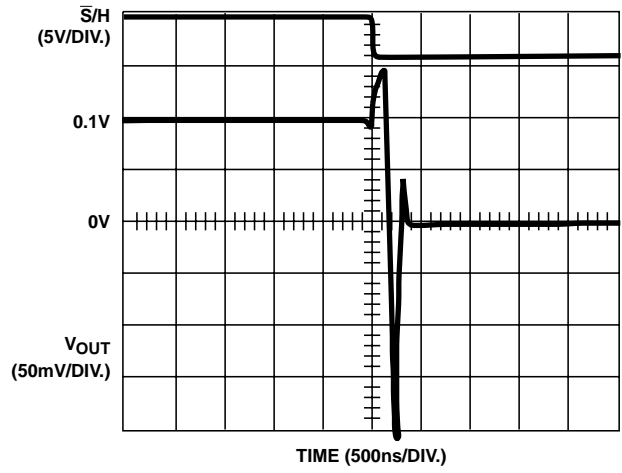

FIGURE 21. ACQUISITION TIME ( $C_H = 1000\text{pF}$ )



## HA-2420, HA-2425

### Die Characteristics

#### DIE DIMENSIONS:

102 mils x 61 mils x 19 mils  
2590 $\mu$ m x 1550 $\mu$ m x 483 $\mu$ m

#### METALLIZATION:

Type: Al, 1% Cu  
Thickness: 16k $\text{\AA}$   $\pm$  2k $\text{\AA}$

#### SUBSTRATE POTENTIAL:

V-

#### BACKSIDE FINISH:

Gold, Nickel, Silicon, etc.

#### PASSIVATION:

Type: Nitride ( $\text{Si}_3\text{N}_4$ ) over Silox ( $\text{SiO}_2$ , 5% Phos.)  
Silox Thickness: 12k $\text{\AA}$   $\pm$  2k $\text{\AA}$   
Nitride Thickness: 3.5k $\text{\AA}$   $\pm$  1.5k $\text{\AA}$

#### TRANSISTOR COUNT:

78

#### PROCESS:

Bipolar Dielectric Isolation

### Metallization Mask Layout

HA-2420, HA-2425

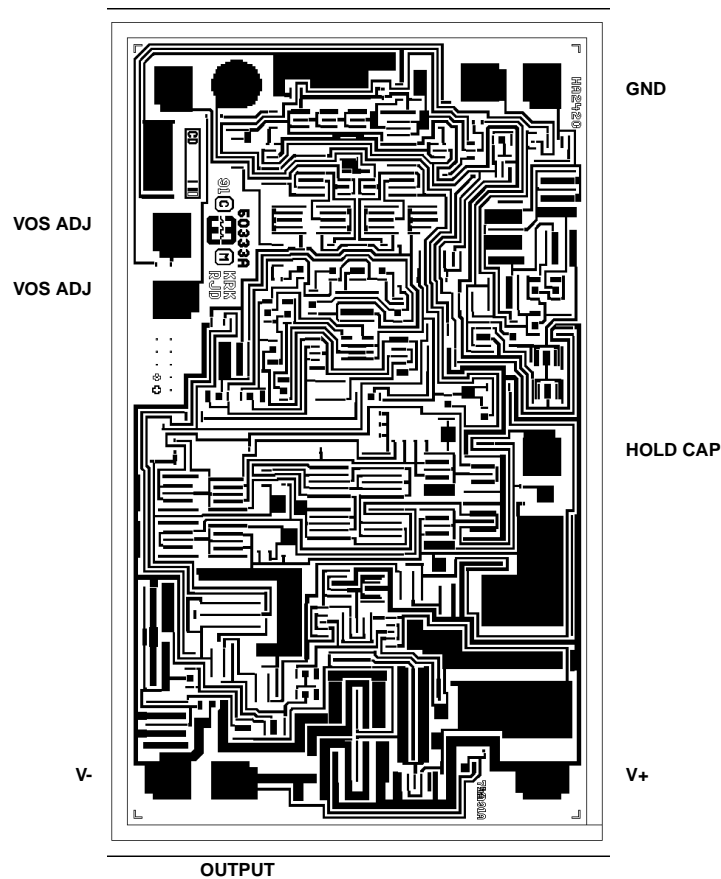

All Intersil semiconductor products are manufactured, assembled and tested under **ISO9000** quality systems certification.

*Intersil products are sold by description only. Intersil Corporation reserves the right to make changes in circuit design and/or specifications at any time without notice. Accordingly, the reader is cautioned to verify that data sheets are current before placing orders. Information furnished by Intersil is believed to be accurate and reliable. However, no responsibility is assumed by Intersil or its subsidiaries for its use; nor for any infringements of patents or other rights of third parties which may result from its use. No license is granted by implication or otherwise under any patent or patent rights of Intersil or its subsidiaries.*

For information regarding Intersil Corporation and its products, see web site <http://www.intersil.com>