

Radiation Hardened Single 8/Differential 4-Channel CMOS Analog Multiplexers

These radiation hardened monolithic CMOS multiplexers each include an array of eight analog switches, a digital decode circuit for channel selection, a voltage reference for logic thresholds, and an ENABLE input for device selection when several multiplexers are present.

The Dielectric Isolation (DI) process used in fabrication of these devices eliminates the problem of latch-up. Also, DI offers much lower substrate leakage and parasitic capacitance than conventional junction-isolated CMOS. Switches are guaranteed to break-before-make, so that two channels are never shorted together. The switching threshold for each digital input is established by an internal +5V reference, providing a guaranteed minimum 2.4V for logic "1" and maximum 0.8 for logic "0". This allows direct interface without pull-up resistors to signals from most logic families: CMOS, TTL, DTL and some PMOS. For protection against transient overvoltage, the digital inputs include a series 200Ω resistor and a diode clamp to each supply. The HS-0508RH is an eight channel single-ended multiplexer, and the HS-0509RH is a four channel differential version. If input overvoltage protection is needed, the HS-0548RH and HS-0549RH multiplexers are recommended.

Specifications for Rad Hard QML devices are controlled by the Defense Supply Center in Columbus (DSCC). The SMD numbers listed here must be used when ordering.

Detailed Electrical Specifications for these devices are contained in SMD 5962-95692. A "hot-link" is provided on our homepage for downloading.
<http://www.intersil.com/spacedefense/space.htm>

Features

- Electrically Screened to SMD # 5962-95692
- QML Qualified per MIL-PRF-38535 Requirements
- Gamma Dose 1 x 10⁴RAD(Si)
- No Latch-Up
- No Channel Interaction During Overvoltage
- Low On Resistance <200Ω (Typ)
- 44V Maximum Power Supply
- Break-Before-Make Switch
- Analog Signal Range ±15V
- Access Time <300ns (Typ)

Applications

- Data Acquisition Systems
- Control Systems
- Telemetry

Ordering Information

ORDERING NUMBER	INTERNAL MKT. NUMBER	TEMP. RANGE (°C)
5962D9569201VEA	HS1-0508RH-Q	-55 to 125
5962D9569201VEC	HS1B-0508RH-Q	-55 to 125
5962D9569202VEA	HS1-0509RH-Q	-55 to 125
5962D9569202VEC	HS1B-0509RH-Q	-55 to 125

Pinouts

**HS-0508RH GDIP1-T16 (CERDIP)
OR CDIP2-T16 (SBDIP)
TOP VIEW**

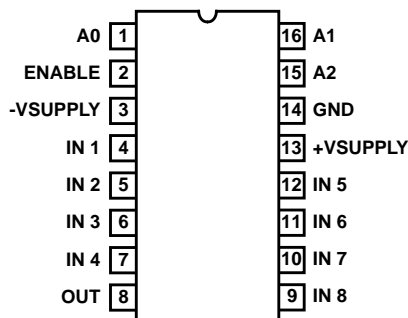

**HS-0509RH GDIP1-T16 (CERDIP)
OR CDIP2-T16 (SBDIP)
TOP VIEW**

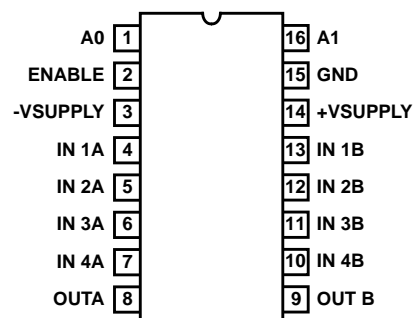

Functional Diagrams

HS-0508RH

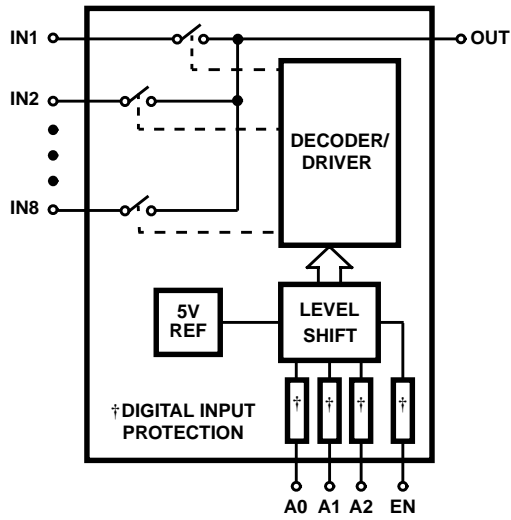

HS-0509RH

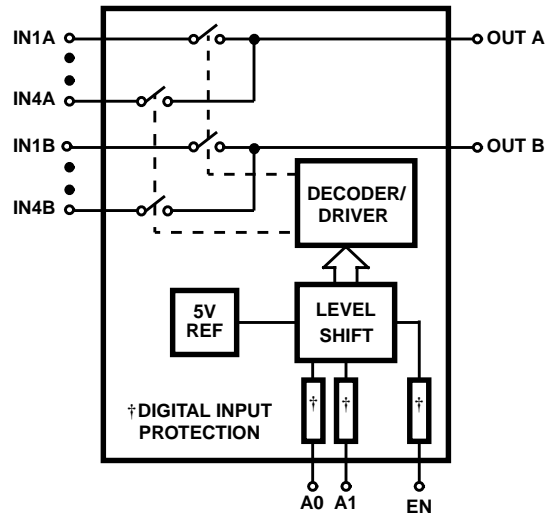

HS-0508RH TRUTH TABLE

A2	A1	A0	EN	"ON" CHANNEL
X	X	X	L	NONE
L	L	L	H	1
L	L	H	H	2
L	H	L	H	3
L	H	H	H	4
H	L	L	H	5
H	L	H	H	6
H	H	L	H	7
H	H	H	H	8

HS-0509RH TRUTH TABLE

A1	A0	EN	"ON" CHANNEL PAIR
X	X	L	NONE
L	L	H	1
L	H	H	2
H	L	H	3
H	H	H	4

Schematic Diagrams

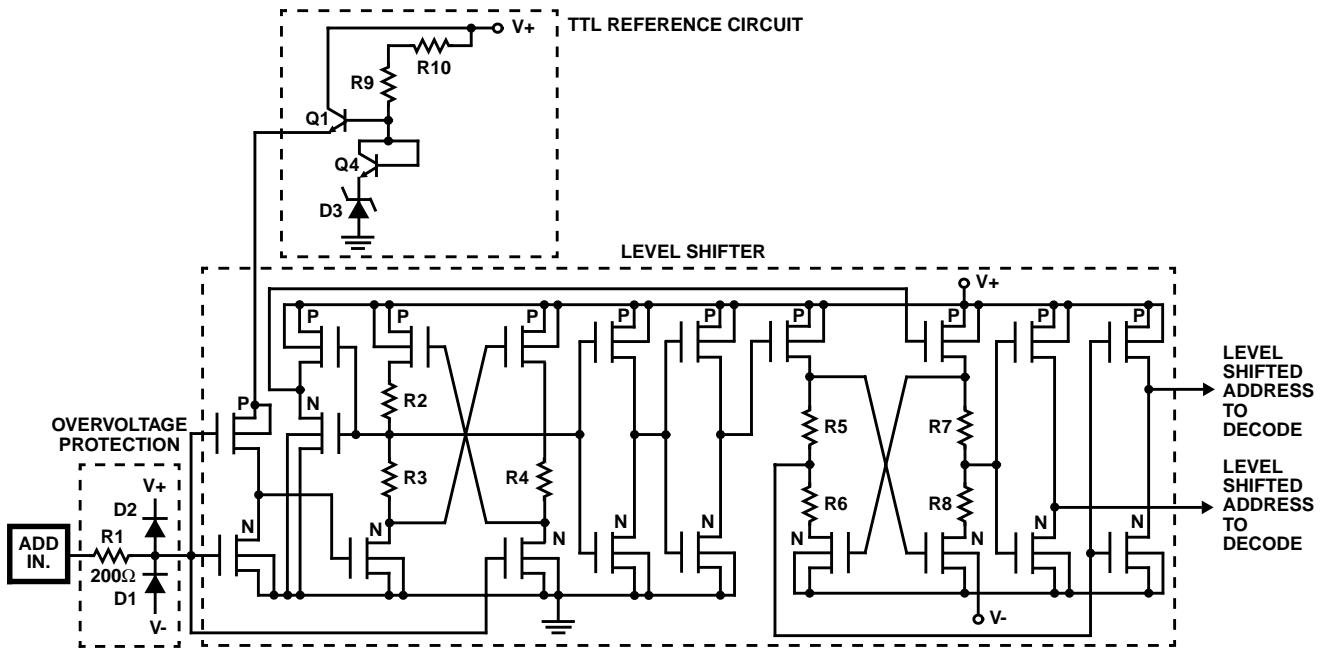

FIGURE 1. ADDRESS INPUT BUFFER AND LEVEL SHIFTER

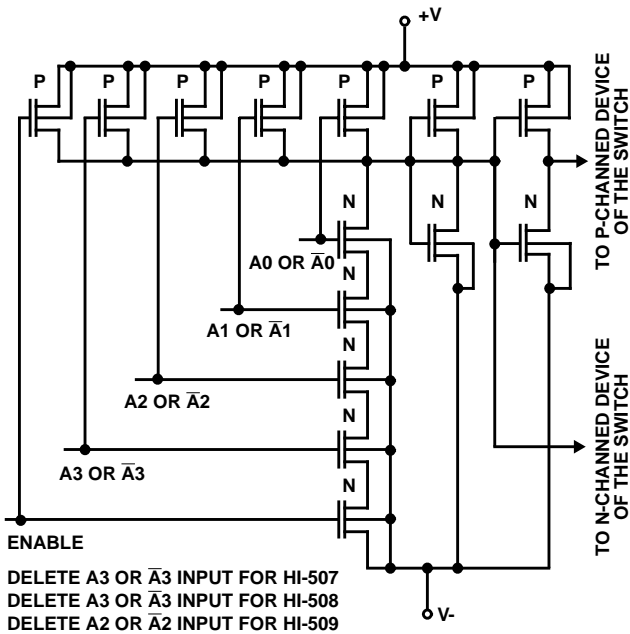

FIGURE 2. ADDRESS DECODER

DELETE A3 OR A3-bar INPUT FOR HI-507
 DELETE A3 OR A3-bar INPUT FOR HI-508
 DELETE A2 OR A2-bar INPUT FOR HI-509

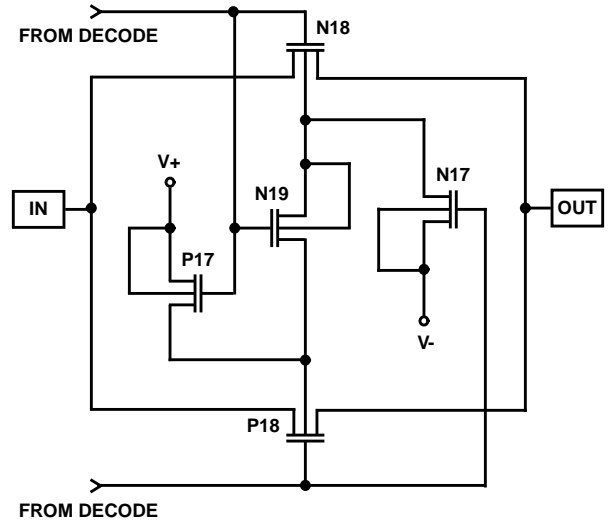
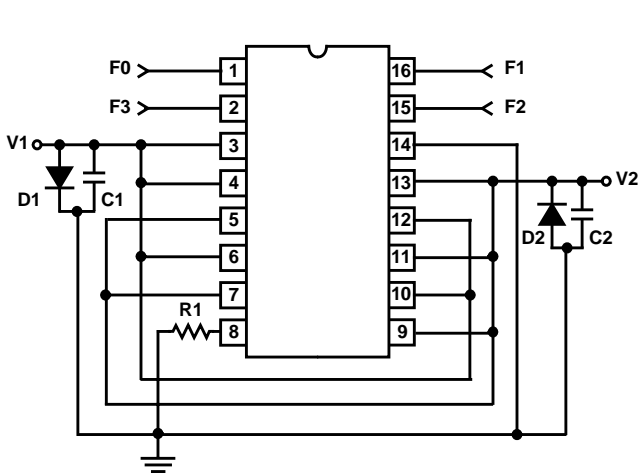

FIGURE 3. MULTIPLEX SWITCH

Burn-In/Life Test Circuits



**HS-0508RH
DYNAMIC BURN-IN AND LIFE TEST CIRCUIT**

V1 = -15V maximum, -16V minimum
 V2 = +15V minimum, +16V maximum
 R1 = 10kΩ ±5% 1/4W
 C1 = C2 = 0.01μF minimum (per socket) or 0.1μF minimum (per row)
 D1 = D2 = 1N4002 (or equivalent)
 F0 = 100kHz 50% duty cycle; VIL = 0.8V max; VIH = 4.0V min.
 F1 = F0/2
 F2 = F1/2
 F3 = F2/2

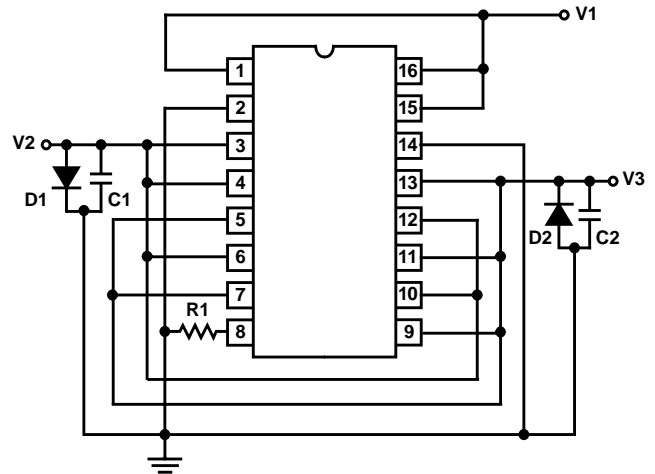

**HS-0508RH
STATIC BURN-IN TEST CIRCUIT**

V1 = 5V minimum, 6V maximum
 V2 = -15V maximum, -16V minimum
 V3 = +15V minimum, +16V maximum
 R1 = 10kΩ ±5% 1/4W
 C1 = C2 = 0.01μF minimum (per socket) or 0.1μF minimum (per row)
 D1 = D2 = 1N4002 (or equivalent)

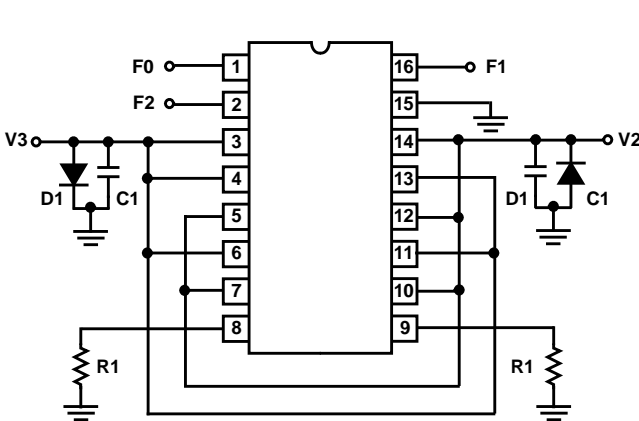

**HS-0509RH
DYNAMIC BURN-IN AND LIFE TEST CIRCUIT**

V2 = +15.5V, ±0.5V
 V3 = -15.5V, ±0.5V
 R1 = 10kΩ, ±5%
 C1 = 0.1μF minimum (per socket)
 D1 = 1N4002 or equivalent (per board)
 F0 = 100kHz, ±10%; F1 = F0/2; F2 = F1/2, 50% duty cycle,
 VIL = 0.8V max.; VIH = 4.0V min.

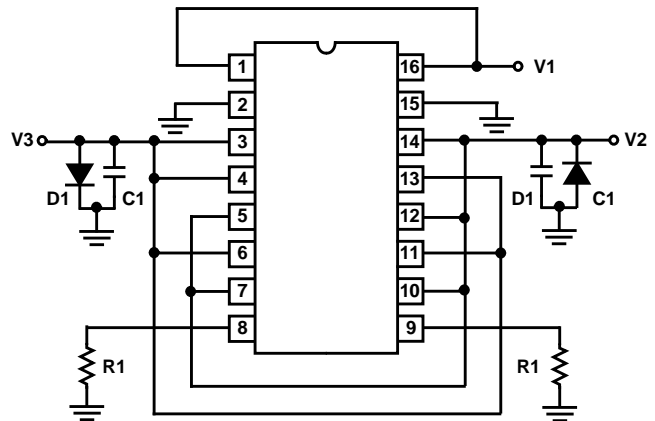

**HS-0509RH
STATIC BURN-IN TEST CIRCUIT**

V1 = +5.5V, ±0.5V
 V2 = +15.5V, ±0.5V
 V3 = -15.5V, ±0.5V
 R1 = 10kΩ, ±10%
 C1 = 0.1μF minimum (per socket)
 D1 = 1N4002 or equivalent (per board)

Irradiation Circuits

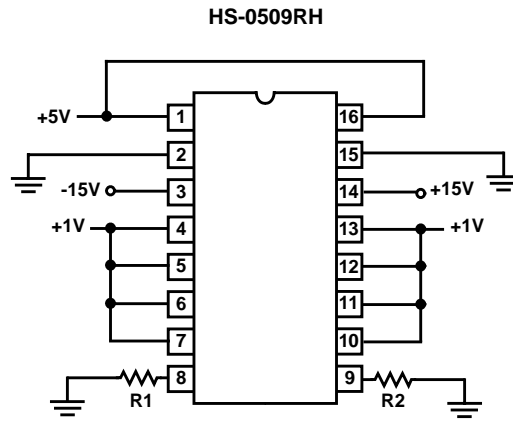

$R1 = R2 = 10k\Omega \pm 5\%$

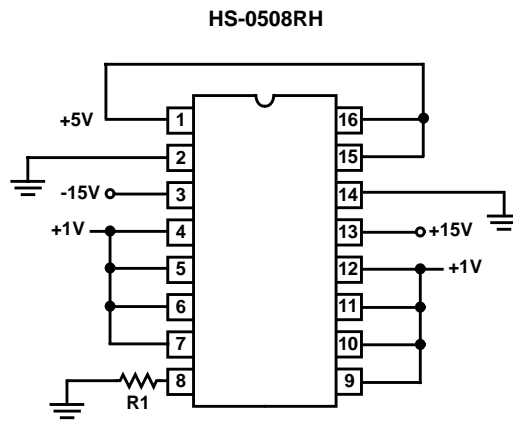

$R1 = 10k\Omega \pm 5\%$

Die Characteristics

DIE DIMENSIONS:

81.9mils x 90.2mils x 19mils

INTERFACE MATERIALS:

Glassivation:

Type: Nitride
Thickness: 7kÅ ±0.7kÅ

Top Metallization:

Type: Al
Thickness: 16kÅ ±2kÅ

Substrate:

CMOS
Dielectric Isolation

Backside Finish:

Silicon

ASSEMBLY RELATED INFORMATION:

Substrate Potential:

Unbiased (DI)

ADDITIONAL INFORMATION:

Worst Case Current Density:

< 2.0 x 10⁵ A/cm²

Transistor Count:

HS-0508RH 243
HS-0509RH 243

Metallization Mask Layout

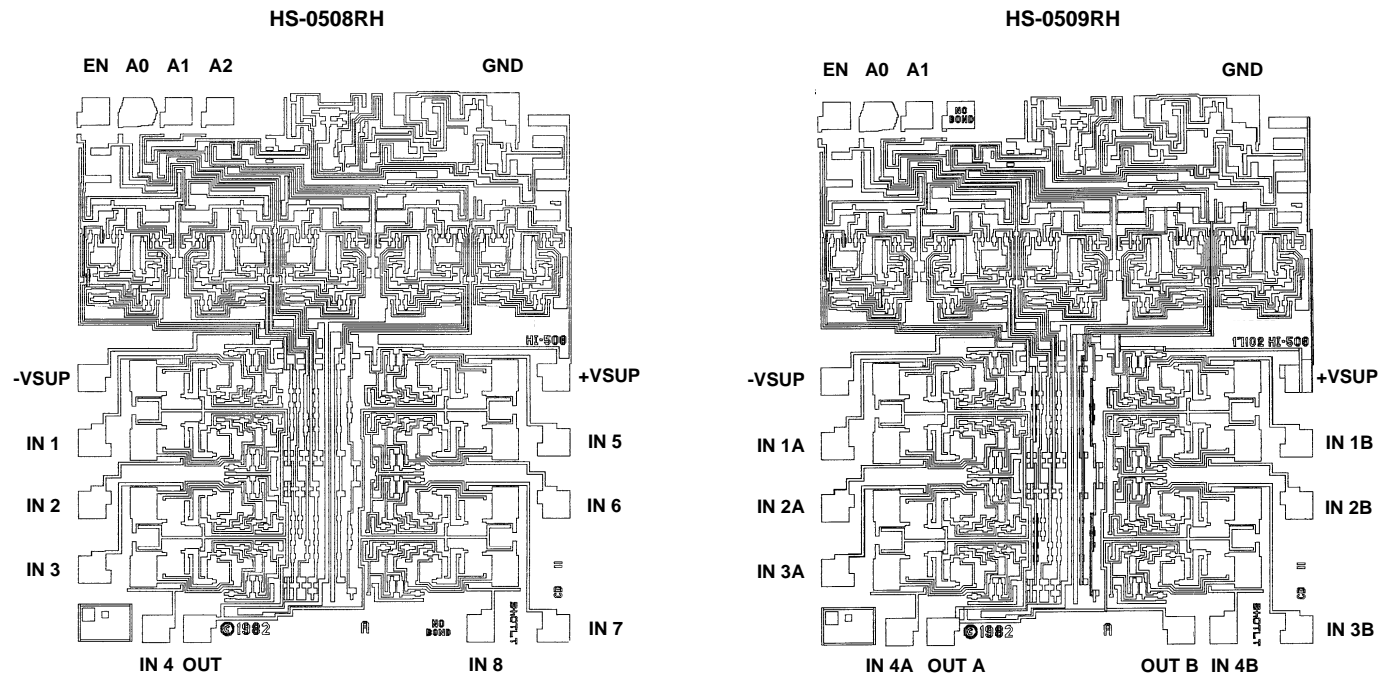

NOTE: Pad numbers correspond to DIP pin numbers only.

All Intersil semiconductor products are manufactured, assembled and tested under **ISO9000** quality systems certification.

Intersil semiconductor products are sold by description only. Intersil Corporation reserves the right to make changes in circuit design and/or specifications at any time without notice. Accordingly, the reader is cautioned to verify that data sheets are current before placing orders. Information furnished by Intersil is believed to be accurate and reliable. However, no responsibility is assumed by Intersil or its subsidiaries for its use; nor for any infringements of patents or other rights of third parties which may result from its use. No license is granted by implication or otherwise under any patent or patent rights of Intersil or its subsidiaries.

For information regarding Intersil Corporation and its products, see web site <http://www.intersil.com>

Sales Office Headquarters

NORTH AMERICA

Intersil Corporation
P. O. Box 883, Mail Stop 53-204
Melbourne, FL 32902
TEL: (407) 724-7000
FAX: (407) 724-7240

EUROPE

Intersil SA
Mercure Center
100, Rue de la Fusee
1130 Brussels, Belgium
TEL: (32) 2.724.2111
FAX: (32) 2.724.22.05

ASIA

Intersil (Taiwan) Ltd.
7F-6, No. 101 Fu Hsing North Road
Taipei, Taiwan
Republic of China
TEL: (886) 2 2716 9310
FAX: (886) 2 2715 3029