

THYRISTOR / DIODE and  
THYRISTOR / THYRISTOR

SUPER MAGN-A-PAK™ Power Modules

### Features

- High current capability
- 3000 V<sub>RMS</sub> isolating voltage with non-toxic substrate
- High surge capability
- Industrial standard package
- UL recognition pending

500 A

### Typical Applications

- Motor starters
- DC motor controls - AC motor controls
- Uninterruptable power supplies

### Major Ratings and Characteristics

Parameters	IRK.500..	Units
$I_{T(AV)}$ or $I_{F(AV)}$	500	A
@ $T_C$	82	°C
$I_{T(RMS)}$	900	A
@ $T_C$	82	°C
$I_{TSM}$ or $I_{FSM}$ @ 50Hz	17.8	KA
@ 60Hz	18.7	KA
$I^2t$ @ 50Hz	1591	KA <sup>2</sup> s
@ 60Hz	1452	KA <sup>2</sup> s
$I^2\sqrt{t}$	15910	KA <sup>2</sup> √s
$V_{DRM}/V_{RRM}$ range	800 to 1600	V
$T_{STG}$ range	-40 to 150	°C
$T_J$ range	-40 to 130	°C

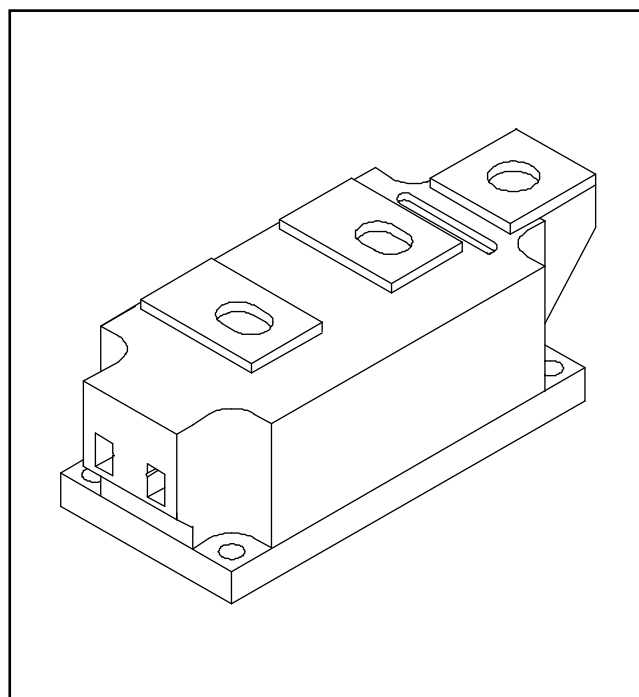

**ELECTRICAL SPECIFICATIONS**

Voltage Ratings

Type number	Voltage Code	$V_{RRM}$ , maximum repetitive peak reverse voltage V	$V_{RSM}$ , maximum non-repetitive peak rev. voltage V	$I_{RRM}$ max. @ $T_J = T_J$ max. mA
IRK.500..	08	800	900	100
	12	1200	1300	
	14	1400	1500	
	16	1600	1700	

On-state Conduction

Parameter	IRK.500..	Units	Conditions	
$I_{T(AV)}$ Maximum average on-state current	500	A	180° conduction, half sine wave	
$I_{F(AV)}$ @ Case temperature	82	°C		
$I_{T(RMS)}$ Maximum RMS on-state current	900	A	180° conduction, half sine wave @ $T_C = 82^\circ\text{C}$	
$I_{TSM}$ Maximum peak, one-cycle, non-repetitive surge current	17.8	KA	Sinusoidal half wave, Initial $T_J = T_J$ max.	
$I_{FSM}$	18.7			t = 10ms No voltage reappplied
	15.0			t = 8.3ms 100% $V_{RRM}$ reappplied
	15.7			t = 10ms 100% $V_{RRM}$ reappplied
$I^2t$ Maximum $I^2t$ for fusing	1591	KA <sup>2</sup> s	Initial $T_J = T_J$ max.	
	1452			t = 10ms No voltage reappplied
	1125			t = 8.3ms 100% $V_{RRM}$ reappplied
	1027			t = 10ms 100% $V_{RRM}$ reappplied
$I^2\sqrt{t}$ Maximum $I^2\sqrt{t}$ for fusing	15910	KA <sup>2</sup> √s	t = 0.1 to 10ms, no voltage reappplied	
$V_{T(TO)1}$ Low level value of threshold voltage	0.85	V	$(16.7\% \times \pi \times I_{T(AV)} < I < \pi \times I_{T(AV)})$ , $T_J = T_J$ max.	
$V_{T(TO)2}$ High level value of threshold voltage	0.93		$(I > \pi \times I_{T(AV)})$ , $T_J = T_J$ max.	
$r_{t1}$ Low level value of on-state slope resistance	0.36	mΩ	$(16.7\% \times \pi \times I_{T(AV)} < I < \pi \times I_{T(AV)})$ , $T_J = T_J$ max.	
$r_{t2}$ High level value of on-state slope resistance	0.32		$(I > \pi \times I_{T(AV)})$ , $T_J = T_J$ max.	
$V_{TM}$ Maximum on-state or forward voltage drop	1.50	V	$I_{pk} = 1500\text{A}$ , $T_J = 25^\circ\text{C}$ , $t_p = 10\text{ms}$ sine pulse	
$I_H$ Maximum holding current	500	mA	$T_J = 25^\circ\text{C}$ , anode supply 12V resistive load	
$I_L$ Typical latching current	1000			

Switching

Parameter	IRK.500..	Units	Conditions
di/dt Maximum rate of rise of turned-on current	1000	A/μs	$T_J = T_J$ max., $I_{TM} = 400\text{A}$ , $V_{DRM}$ applied
$t_d$ Typical delay time	2.0	μs	Gate current 1A, $di_g/dt = 1\text{A}/\mu\text{s}$ $V_d = 0.67\% V_{DRM}$ , $T_J = 25^\circ\text{C}$
$t_q$ Typical turn-off time	200	μs	$I_{TM} = 750\text{A}$ , $T_J = T_J$ max, $di/dt = -60\text{A}/\mu\text{s}$ , $V_R = 50\text{V}$ , $dv/dt = 20\text{V}/\mu\text{s}$ , Gate 0 V 100Ω

Blocking

Parameter	IRK.500..	Units	Conditions
dv/dt Maximum critical rate of rise of off-state voltage	1000	V/ $\mu$ s	$T_J = 130^\circ\text{C}$ ., linear to $V_D = 80\% V_{\text{DRM}}$
$V_{\text{INS}}$ RMS isolation voltage	3000	V	t = 1 s
$I_{\text{RRM}}$ Maximum peak reverse and off-state leakage current $I_{\text{DRM}}$	100	mA	$T_J = T_J \text{ max.}$ ., rated $V_{\text{DRM}}/V_{\text{RRM}}$ applied

Triggering

Parameter	IRK.500..	Units	Conditions
$P_{\text{GM}}$ Maximum peak gate power	10	W	$T_J = T_J \text{ max.}$ ., $t_p \leq 5\text{ms}$
$P_{\text{G(AV)}}$ Maximum peak average gate power	2.0	W	$T_J = T_J \text{ max.}$ ., f = 50Hz, d% = 50
+ $I_{\text{GM}}$ Maximum peak positive gate current	3.0	A	$T_J = T_J \text{ max.}$ ., $t_p \leq 5\text{ms}$
+ $V_{\text{GM}}$ Maximum peak positive gate voltage	20	V	
- $V_{\text{GM}}$ Maximum peak negative gate voltage	5.0	V	
$I_{\text{GT}}$ Max. DC gate current required to trigger	200	mA	$T_J = 25^\circ\text{C}$ $V_{\text{ak}} 12\text{V}$
$V_{\text{GT}}$ DC gate voltage required to trigger	3.0	V	$T_J = 25^\circ\text{C}$ $V_{\text{ak}} 12\text{V}$
$I_{\text{GD}}$ DC gate current not to trigger	10	mA	$T_J = T_J \text{ max.}$
$V_{\text{GD}}$ DC gate voltage not to trigger	0.25	V	

Thermal and Mechanical Specifications

Parameter	IRK.500..	Units	Conditions
$T_J$ Max. junction operating temperature range	- 40 to 130	$^\circ\text{C}$	
$T_{\text{stg}}$ Max. storage temperature range	- 40 to 150		
$R_{\text{thJC}}$ Max. thermal resistance, junction to case	0.065	K/W	Per junction, DC operation
$R_{\text{thC-hs}}$ Max. thermal resistance, case to heatsink	0.02	K/W	
T Mounting torque $\pm 10\%$ SMAP to heatsink busbar to SMAP	6 - 8	Nm	A mounting compound is recommended and the torque should be rechecked after a period of 3 hours to allow for the spread of the compound
	12 - 15		
wt Approximate weight	1500	g	
Case style	Super Magn-a-Pak		See outline table

# IRK.500.. Series

## $\Delta R_{thJC}$ Conduction

(The following table shows the increment of thermal resistance  $R_{thJC}$  when devices operate at different conduction angles than DC)

Conduction angle	Sinusoidal conduction	Rectangular conduction	Units	Conditions
180°	0.009	0.006	K/W	$T_J = T_{J \text{ max.}}$
120°	0.011	0.011		
90°	0.014	0.015		
60°	0.021	0.022		
30°	0.037	0.038		

## Ordering Information Table

**Device Code**

<b>IRK</b>	<b>T</b>	<b>500</b>	<b>-</b>	<b>16</b>
------------	----------	------------	----------	-----------

①
②
③
④

- 1** - Module type
- 2** - Circuit configuration (See Circuit Configurations Table)
- 3** - Current rating
- 4** - Voltage code: Code x 100 =  $V_{RRM}$  (See Voltage Ratings Table)

## Circuit Configurations Table

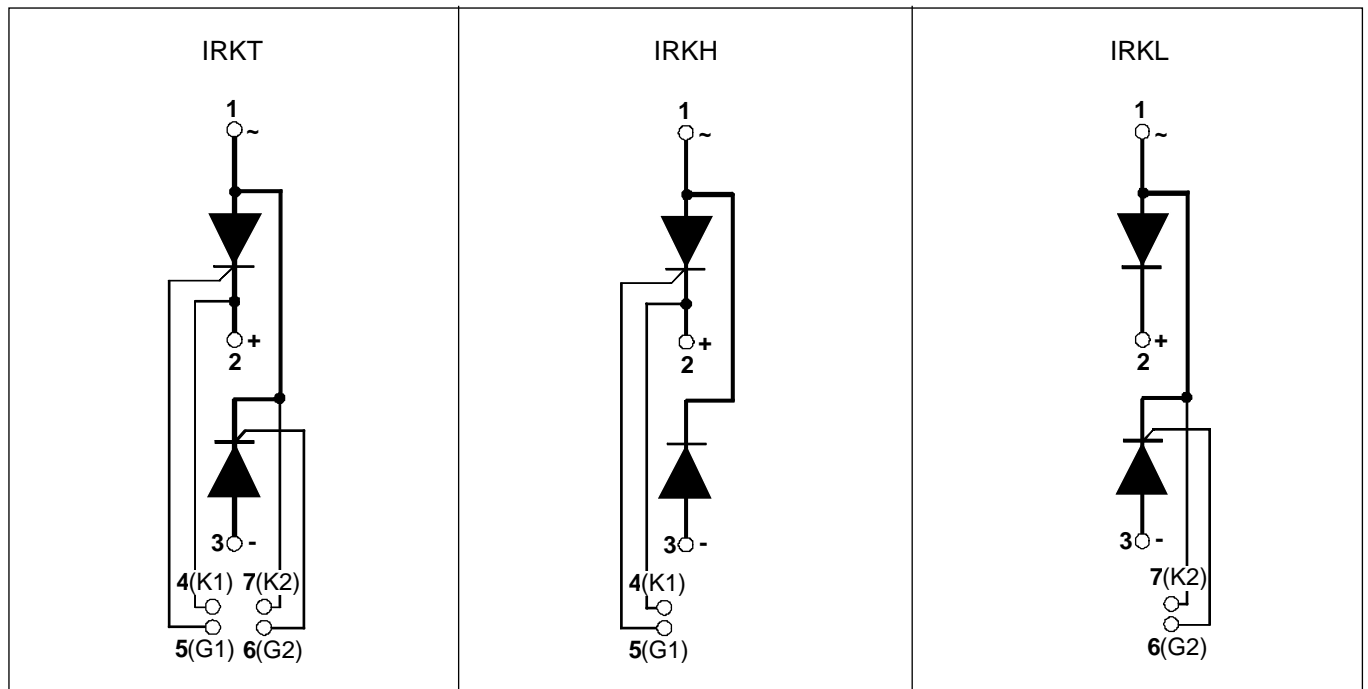

Outline Table

All dimensions in millimeters (inches)

