

IRU1206 / IRU1207 / IRU1208 / IRU1209

1A VERY LOW DROPOUT POSITIVE FIXED AND ADJUSTABLE REGULATORS

FEATURES

- Low Dropout Voltage (500mV at 1A)
- 1% Voltage Reference Accuracy
- Low Ground Current
- 1 μ A Maximum Quiescent Current in Shutdown (IRU1207, IRU1208)
- Fast Transient Response
- Current Limit and Thermal Shutdown
- Error Flag Signal for Output out of Regulation (IRU1207, IRU1208)

APPLICATIONS

- 2.5V Supply from 3.3V Input for the new generation of Logic ICs
- Computer Mother Board, Add-On Cards
- High Efficiency Post Regulator in Switch Mode Power Supply (SMPS)

DESCRIPTION

The IRU1206 family of devices are ultra low dropout 1A regulators using PNP transistor as the pass element. These products are ideal when a single input supply is only available and the dropout voltage is less than 1V, exceeding the minimum dropout characteristics of NPN/PNP hybrid regulators. One common application of these regulators is where input is 3.3V and a 2.5V output is needed.

Besides the low dropout of less than 0.5V, other features of the family of the parts are: micro-power shut-down capability and output UVLO detection where Flag pin is switched low when output is below 5% of its nominal point.

TYPICAL APPLICATION

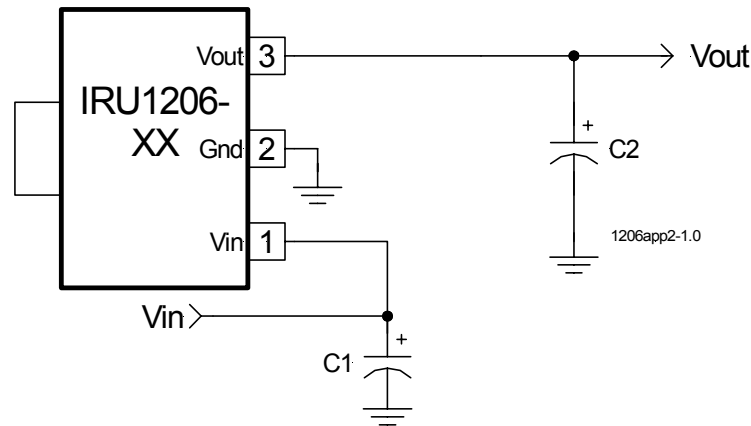

Figure 1 - Typical application of the 1206-XX in a 3-Pin SOT-223 package.

PACKAGE ORDER INFORMATION

T _J (°C)	2-PIN TO-252 (D-PAK)	3-PIN SOT-223 (Y)	8-PIN PLASTIC SOIC POWER (S)	VOLTAGE	PIN FUNCTIONS
0 To 125	IRU1206-18CD	IRU1206-18CY	NA	1.8V	V _{IN} , V _{OUT} , Gnd
0 To 125	IRU1206-25CD	IRU1206-25CY	NA	2.5V	V _{IN} , V _{OUT} , Gnd
0 To 125	IRU1206-33CD	IRU1206-33CY	NA	3.3V	V _{IN} , V _{OUT} , Gnd
0 To 125	NA	NA	IRU1207-18CS	1.8V	V _{IN} , V _{OUT} , Gnd, Enable, Flag
0 To 125	NA	NA	IRU1207-25CS	2.5V	V _{IN} , V _{OUT} , Gnd, Enable, Flag
0 To 125	NA	NA	IRU1207-33CS	3.3V	V _{IN} , V _{OUT} , Gnd, Enable, Flag
0 To 125	NA	NA	IRU1208CS	Adj	V _{IN} , V _{OUT} , Gnd, Flag, Adj
0 To 125	NA	NA	IRU1209CS	Adj	V _{IN} , V _{OUT} , Gnd, Enable, Adj

IRU1206 / IRU1207 / IRU1208 / IRU1209

ABSOLUTE MAXIMUM RATINGS

Input Voltage (V_{IN})	12V
Enable Input Voltage	12V
Storage Temperature Range	-65°C To 150°C
Operating Junction Temperature Range	0°C To 135°C

PACKAGE INFORMATION

3-PIN PLASTIC TO-252 (D-Pak)		3-PIN PLASTIC SOT-223 (Y)	
<p>IRU1206</p> <p>FRONT VIEW</p> <p>Tab is Gnd</p> <p>$\theta_{JA}=70^{\circ}\text{C/W}$ for 0.5" Sq pad</p>		<p>IRU1206</p> <p>TOP VIEW</p> <p>Tab is Gnd</p> <p>$\theta_{JA}=90^{\circ}\text{C/W}$ for 0.4" Sq pad</p>	
8-PIN PLASTIC POWER SOIC (S)			
<p>IRU1207</p> <p>TOP VIEW</p> <p>Enable 1, Vin 2, Vout 3, Flag 4, 5 Gnd, 6 Gnd, 7 Gnd, 8 Gnd</p> <p>$\theta_{JA}=55^{\circ}\text{C/W}$ for 1" Sq pad</p>		<p>IRU1208</p> <p>TOP VIEW</p> <p>Flag 1, Vin 2, Vout 3, Adj 4, 5 Gnd, 6 Gnd, 7 Gnd, 8 Gnd</p> <p>$\theta_{JA}=55^{\circ}\text{C/W}$ for 1" Sq pad</p>	
		<p>IRU1209</p> <p>TOP VIEW</p> <p>Enable 1, Vin 2, Vout 3, Adj 4, 5 Gnd, 6 Gnd, 7 Gnd, 8 Gnd</p> <p>$\theta_{JA}=55^{\circ}\text{C/W}$ for 1" Sq pad</p>	

ELECTRICAL SPECIFICATIONS

Unless otherwise specified, these specifications apply over $C_{IN}=C_{OUT}=10\mu\text{F}$, $V_{IN}=V_O+1\text{V}$, $V_{OUT}=V_{FB}$ (For adjustable version only), and $T_A=25^{\circ}\text{C}$. Typical values refer to $T_A=25^{\circ}\text{C}$. Low duty cycle pulse testing is used which keeps junction and case temperatures equal to the ambient temperature.

PARAMETER	SYM	TEST CONDITION	MIN	TYP	MAX	UNITS
Initial Voltage Accuracy See Table 1 for nominal values	V_O	$I_O=10\text{mA}$, $T_A=25^{\circ}\text{C}$ (Note 4)	-1 -1.3		1 1.3	%
Line Regulation	ΔV_I	$V_O + 1\text{V} < V_{IN} < 12$		0.5	1	%
Load Regulation (Note 1)	ΔV_L	$10\text{mA} < I_O < 1\text{A}$ $1\text{mA} < I_O < 150\text{mA}$		0.5	0.7 0.5	% %
Output Voltage Temp Coef.	$\Delta V_{O(T)}$			20	100	ppm/ $^{\circ}\text{C}$
Dropout Voltage (Note 2)	$\Delta V_{I(O)}$	$I_O=100\text{mA}$ (Note 4) $I_O=500\text{mA}$ (Note 4) $I_O=1000\text{mA}$ (Note 4)		100 300 500	200 400 650	mV
Ground Current (Note 3)	I_Q	$V_{IN}=V_O + 1$ for all conditions: $I_O=100\text{mA}$ (Note 4) $I_O=500\text{mA}$ (Note 4) $I_O=1000\text{mA}$ (Note 4)			3 15 50	mA
Current Limit	I_{CL}	$V_O=5\%$ Below Regulation Point	1.1	1.4		A
Minimum Input Voltage	$V_{IN(\text{min})}$			2.1	2.3	V
IRU1208, IRU1209						
Adjust Pin Current	I_{ADJ}	$V_{IN}=2.5\text{V}$, $V_O=V_{ADJ}$ (Note 4)			0.1	μA
Minimum Load Current	$I_{O(\text{min})}$		1			mA

IRU1206 / IRU1207 / IRU1208 / IRU1209

IRU1207, IRU1209	SYM	TEST CONDITION	MIN	TYP	MAX	UNITS
Ground Current - SD Activated	$I_{Q(SD)}$	Enable=Open		0.01	1	μA
Enable Pin Input LO Voltage	$V_{EN(L)}$	Regulator OFF (Note 4)			0.8	V
Enable Pin Input HI Voltage	$V_{EN(L)}$	Regulator ON (Note 4)	2			V
Enable Pin Input LO Current		$V_{EN(L)}=0V$ to $0.8V$ (Note 4)		0.1	2	μA
Enable Pin Input HI Current		$V_{EN(L)}=2V$ to V_{in} (Note 4)		100	600	μA
IRU1207, IRU1208						
Flag Output Threshold Voltage	$V_{TH(FG)}$			3.8		% V_o
Flag Output Hysteresis Voltage	V_{HYS}	Output Ramping Up		0.8		% V_o
Flag Output Saturation Voltage	$V_{F(SAT)}$	$I_o=5mA$		400		mV
		$I_o=500\mu A$		230		m

Note 1: Low duty cycle pulse testing with Kelvin connections is required in order to maintain accurate data.

Note 2: Dropout voltage is defined as the minimum differential voltage between V_{IN} and V_{OUT} required to maintain regulation at V_{OUT} . It is measured when the output voltage drops 1% below its nominal value.

Note 3: Ground current is the regulator quiescent current plus the pass transistor current. The total current from the supply is the sum of the load current plus the ground pin current.

Note 4: The specification applies for the junction temperature of 0 to +125°C.

PIN DESCRIPTIONS

PIN SYMBOL	PIN DESCRIPTION
V_{IN} (All devices)	The input pin of the regulator. Typically a large storage capacitor is connected from this pin to ground to insure that the input voltage does not sag below the minimum drop out voltage during the load transient response. This pin must always be 0.6V higher than V_{OUT} in order for the device to regulate properly.
V_{OUT} (All devices)	The output of the regulator. A minimum of 2.2 μF capacitor must be connected from this pin to ground.
Gnd (All devices)	Ground pin. This pin must be connected to the lowest potential in the system and all other pins must be at higher potential with respect to this pin.
Enable (IRU1207, IRU1209)	Enable pin. A low signal or left open on this pin shuts down the output. This pin must be tied HI or to V_{IN} for normal operation.
Flag (IRU1208)	An open collector output that switches low when the output voltage drops about 4% below its expected regulated voltage.
Adj (IRU1208, IRU1209)	A resistor divider from this pin to the V_{OUT} pin and ground sets the output voltage.

APPLICATION INFORMATION

Stability

The IRU120X series of regulators require the use of an output capacitor as part of the frequency compensation in order to make the regulator stable. A minimum of 2.2 μF capacitance and the ESR in the range of 0.5 to 2 Ω insures the stability of the system.

Part Number	Output Voltage
IRU1206-18	1.8V
IRU1206-25	2.5V
IRU1206-33	3.3V
IRU1207-18	1.8V
IRU1207-25	2.5V
IRU1207-33	3.3V
IRU1208	1.24V
IRU1209	1.24V

Table 1 - Output voltage vs. part number.

IRU1206 / IRU1207 / IRU1208 / IRU1209

TYPICAL APPLICATION

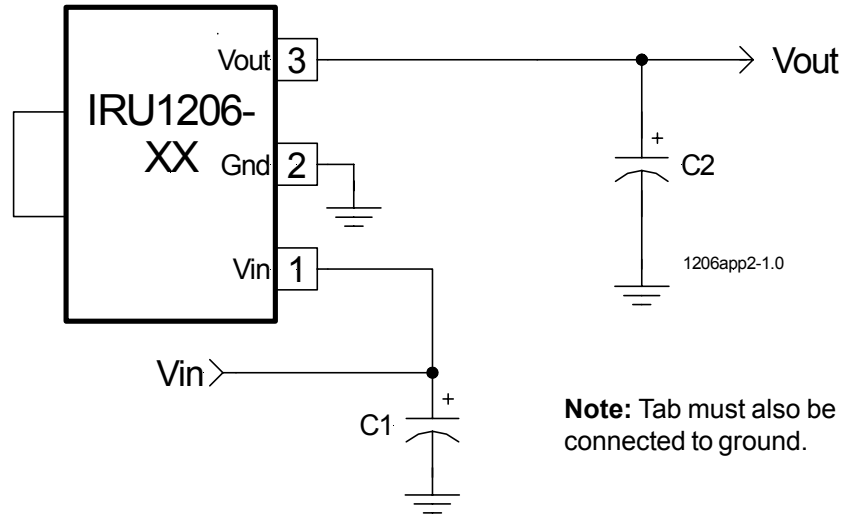

Figure 2 - Typical application of IRU1206.

Ref Desig	Description	Qty	Part #	Manuf
C1	Capacitor	1	10µF, Tantalum	AVX
C2	Capacitor	1	10µF, Tantalum	AVX

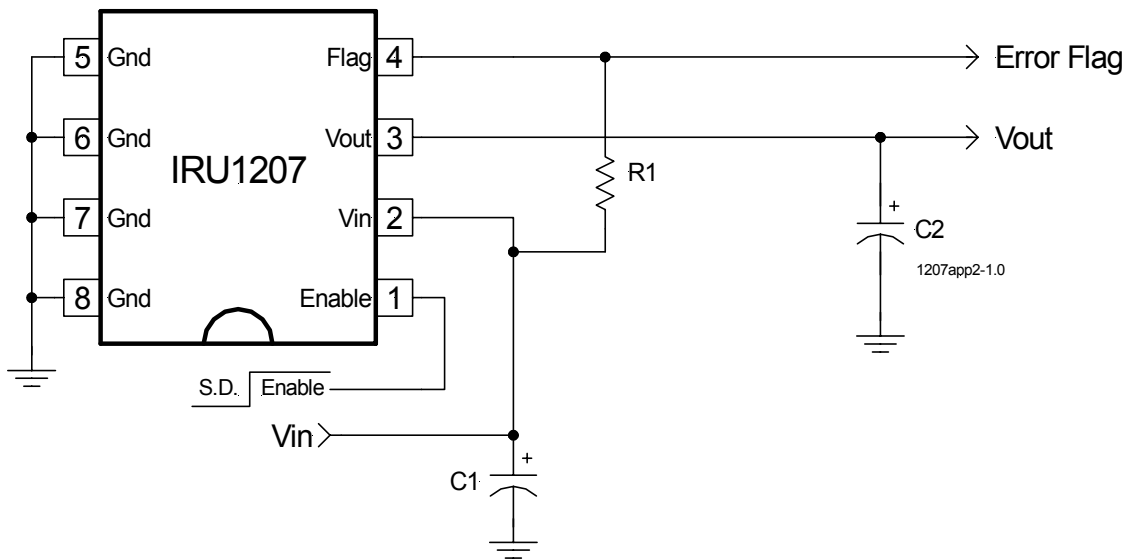

Figure 3 - Typical application of IRU1207.

Ref Desig	Description	Qty	Part #	Manuf
C1	Capacitor	1	10µF, Tantalum	AVX
C2	Capacitor	1	10µF, Tantalum	AVX
R1	Resistor	1	10KΩ, 5%	Panasonic

TYPICAL APPLICATION

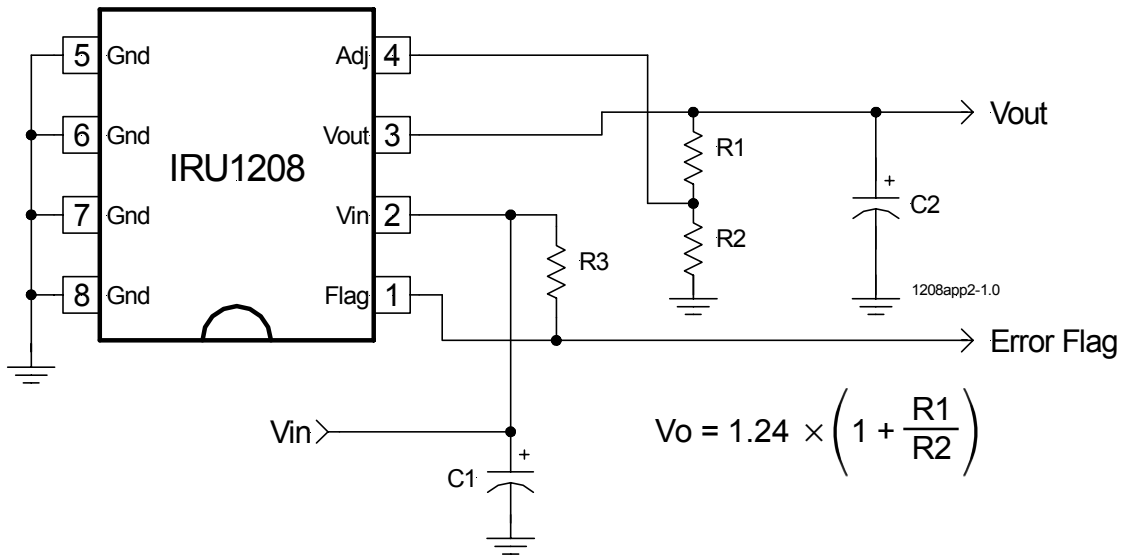

Figure 4 - Typical application of IRU1208 in 3.3V to 2.5V regulator.

Ref Desig	Description	Qty	Part #	Manuf
C1	Capacitor	1	10 μ F, Tantalum	AVX
C2	Capacitor	1	10 μ F, Tantalum	AVX
R1	Resistor	1	127 Ω , 1%	
R2	Resistor	1	124 Ω , 1%	
R3	Resistor	1	10K Ω , 5%	

IRU1206 / IRU1207 / IRU1208 / IRU1209

TYPICAL APPLICATION

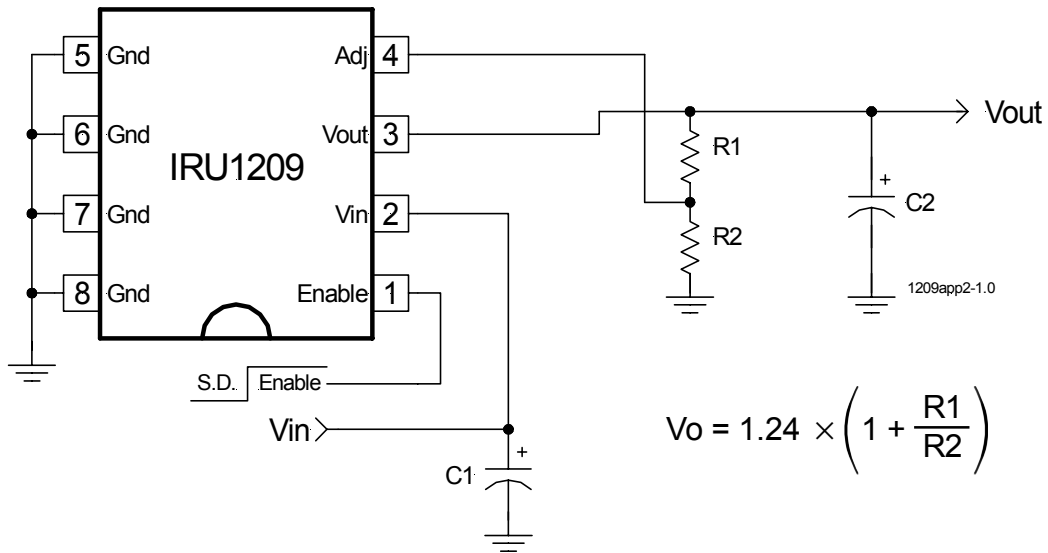
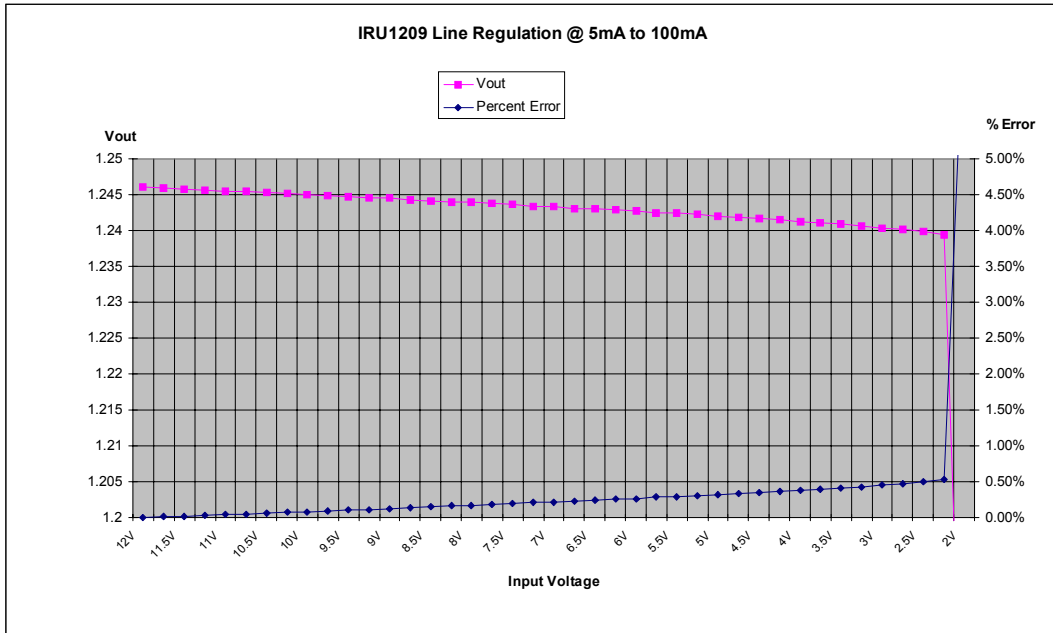

Figure 5 - Typical application of IRU1209 in 3.3V to 2.5V regulator.

Ref Desig	Description	Qty	Part #	Manuf
C1	Capacitor	1	10 μ F, Tantalum	AVX
C2	Capacitor	1	10 μ F, Tantalum	AVX
R1	Resistor	1	127 Ω , 1%	
R2	Resistor	1	124 Ω , 1%	

CHARACTERISTICS



Graph 1

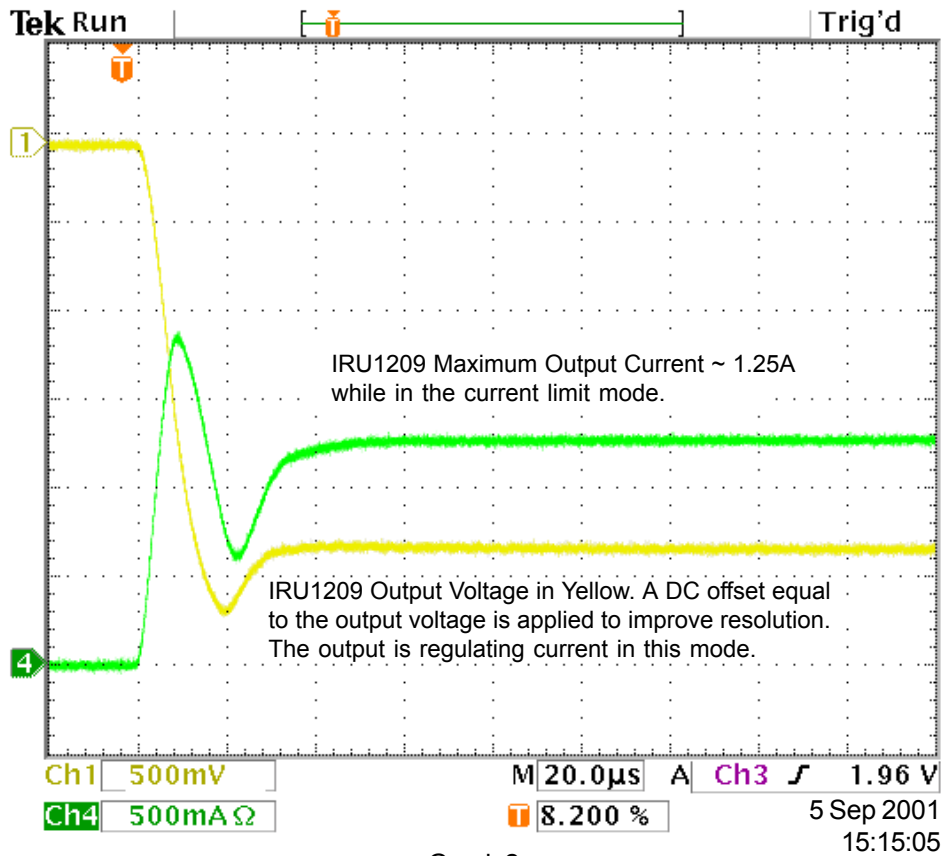

Graph 2

International
IR Rectifier

IR WORLD HEADQUARTERS : 233 Kansas St., El Segundo, California 90245, USA Tel: (310) 252-7105
TAC Fax: (310) 252-7903

Visit us at www.irf.com for sales contact information.
Data and specifications subject to change without notice. 02/01