

**ISO - LOGIC BUFFER
SCHMITT TRIGGER
INTERRUPTER SWITCH**

DESCRIPTION

The ISTS970 and ISTS971 series of transmissive photointerrupters are single channel switches consisting of a Gallium Arsenide infrared emitting diode coupled to a high speed integrated circuit detector. The output incorporates a Schmitt trigger which provides hysteresis for noise immunity and pulse shaping. The gap in the plastic housing provides a means of interrupting the signal with an opaque material, switching the output from an 'OFF' into an 'ON' state.

FEATURES

- Output high under incident light
- Built in Schmitt trigger circuit
- Pull up resistor between V_{CC} and output (ISTS970)
- Open collector output (ISTS971)
- High sensitivity
- 3mm gap between LED and detector
- 1mm aperture over detector

APPLICATIONS

- Floppy disk drives, Copiers, Printers, Facsimilies, VCR's, Cassette tape Recorders, Automatic vending machines

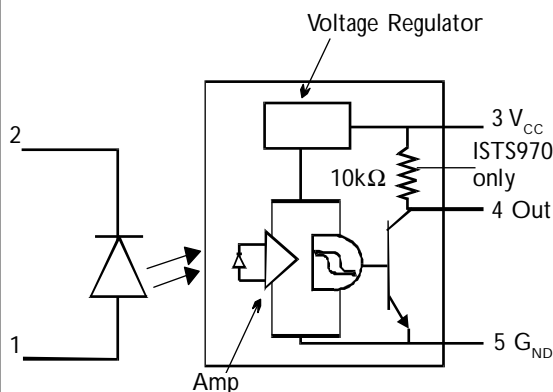

Dimensions in mm

**ISTS970N
ISTS971N**

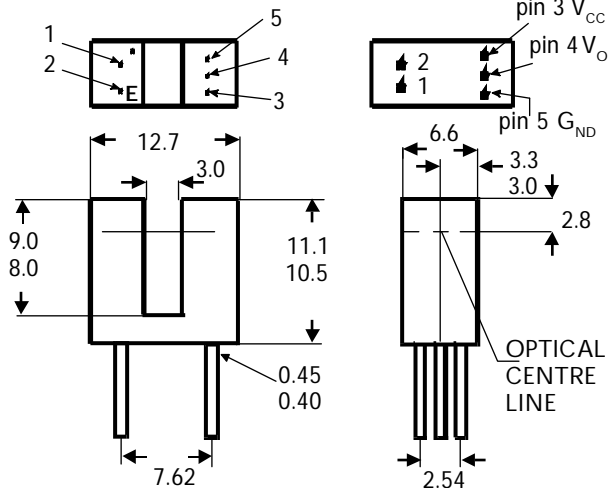

**ISTS970T
ISTS971T**

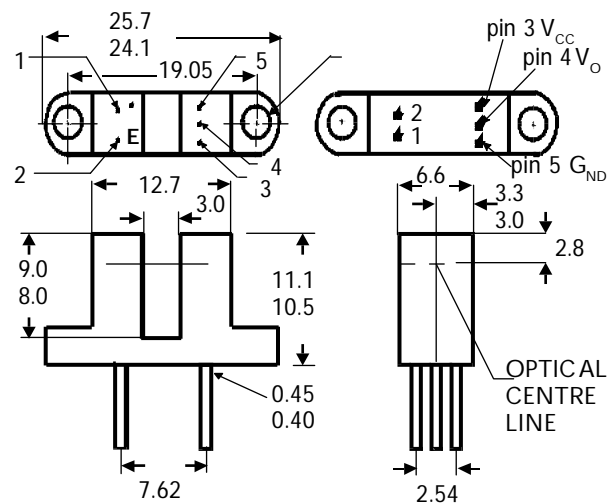

ISOCOM COMPONENTS LTD

Unit 25B, Park View Road West,
Park View Industrial Estate, Brenda Road
Hartlepool, Cleveland, TS25 1YD
Tel: (01429) 863609 Fax : (01429) 863581

ISOCOM INC

720 E., Park Boulevard, Suite 104,
Plano, TX 75074 USA
Tel: (972) 423-5521
Fax: (972) 422-4549

ABSOLUTE MAXIMUM RATINGS (25°C unless otherwise specified)

Storage Temperature	_____	-40°C to +85°C
Operating Temperature	_____	-25°C to +85°C
Lead Soldering Temperature	_____	260°C
(5 secs maximum)		

INFRARED EMITTING DIODE

Power Dissipation	_____	75 mW
Forward Current (Continuous)	_____	50 mA
Forward Current (Peak)	_____	1 A
(Pulse Width ≤ 100µs, Duty Ratio = 0.01)		
Reverse Voltage	_____	6V

PHOTO DETECTOR

Power Dissipation	_____	250 mW
Output Current	_____	50mA
Allowed Range V_{35} (ISTS970)	_____	0 to 17V
	(ISTS971)	0 to 35V
Allowed Range V_{45} (ISTS970)	_____	0 to 17V
	(ISTS971)	0 to 40V

ELECTRICAL CHARACTERISTICS ($T_A = 25^\circ\text{C}$ Unless otherwise noted)

PARAMETER		MIN	TYP	MAX	UNITS	TEST CONDITION
Input	Forward Voltage (V_F)		1.1	1.7	V	$I_F = 20\text{mA}$
	Reverse Voltage (V_R)	6			V	$I_R = 10\mu\text{A}$
	Reverse Current (I_R)			10	μA	$V_R = 3\text{V}$
Detector	Operating Voltage Range V_{CC}	4.75		5.25	V	
	Low Level Supply Current I_{CCL}		2.0	15	mA	$V_{CC} = 5.25\text{V}, I_F = 0\text{mA}$
	High Level Supply Current I_{CCH}		1.0	15	mA	$V_{CC} = 5.25\text{V}, I_F = 15\text{mA}$
	Low Level Output Voltage V_{OL}			0.4	V	$V_{CC} = 4.75\text{V}, I_F = 0\text{mA}$ $I_{OL} = 12.8\text{mA}$
	High Level Output Voltage V_{OH} ISTS970	2.4			V	$V_{CC} = 4.75\text{V}, I_F = 15\text{mA}$ $I_{OH} = -800\mu\text{A}$
	High Level Output Current I_{OH} ISTS971			100	μA	$V_{CC} = 4.75\text{V}, I_F = 15\text{mA}$ $V_{OH} = 30\text{V}$
	Input Forward Threshold Current I_{FT}			15	mA	$V_{CC} = 5\text{V}$
	Propagation Delay Time to Logic High at Output t_{PLH}		5		μs	$V_{CC} = 5\text{V}$ $I_F = 15\text{mA}$ $R_L = 360\Omega$ (ISTS971) or $R_L = 8\text{TTL Loads}$ (ISTS970)
	Propagation Delay Time to Logic Low at Output t_{PHL}		5		μs	
	Rise Time t_r		0.1		μs	
Fall Time t_f		0.05		μs		

Note 1 Special Selections are available on request. Please consult the factory.

Collector Power Dissipation vs. Ambient Temperature

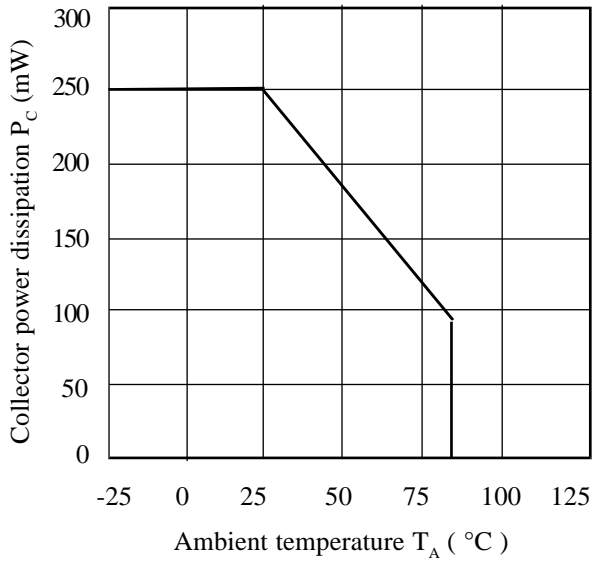

Low Level Output Voltage vs. Low Level Output Current

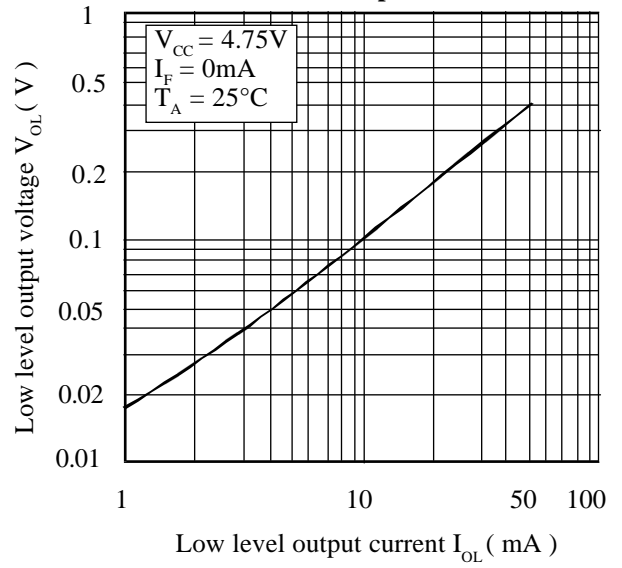

Forward Current vs. Ambient Temperature

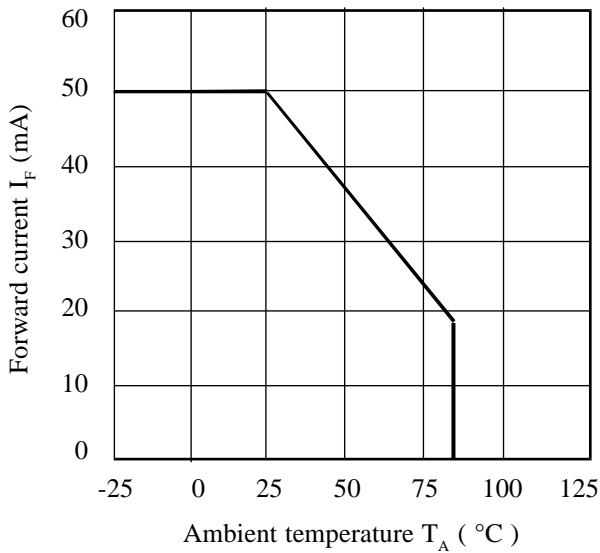

Rise Time, Fall Time vs. Load Resistance

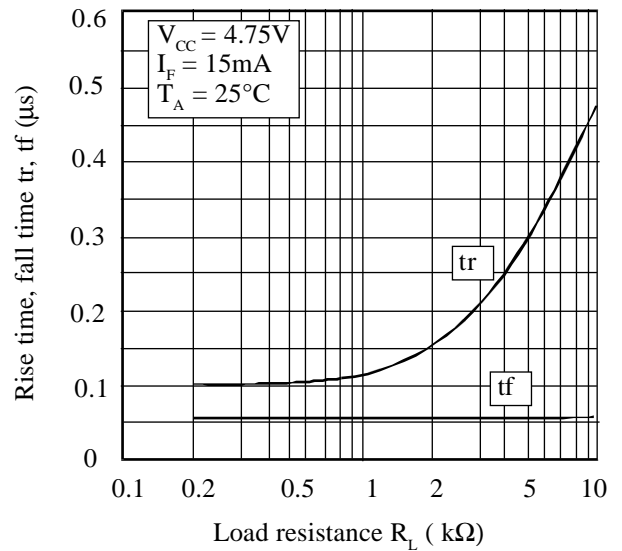

Supply Current vs. Ambient Temperature

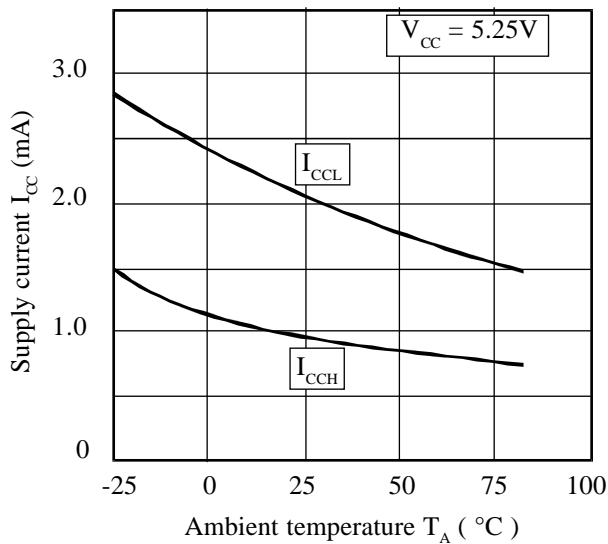

Low Level Output Voltage vs. Ambient Temperature

