

IS41C4405x IS41LV4405x SERIES



4M x 4 (16-MBIT) DYNAMIC RAM WITH FAST PAGE MODE

JUNE 2001

FEATURES

- Fast Page Mode Access Cycle
- TTL compatible inputs and outputs
- Refresh Interval:
 - 2,048 cycles/32 ms
 - 4,096 cycles/64 ms
- Refresh Mode: $\overline{\text{RAS}}$ -Only, $\overline{\text{CAS}}$ -before- $\overline{\text{RAS}}$ (CBR), and Hidden
- Single power supply: 5V \pm 10% or 3.3V \pm 10%
- Byte Write and Byte Read operation via two $\overline{\text{CAS}}$
- Industrial temperature range -40°C to 85°C

DESCRIPTION

The *ISSI* 4405x Series is a 4,194,304 x 4-bit high-performance CMOS Dynamic Random Access Memory. The Fast Page Mode allows 2,048 or 4096 random accesses within a single row with access cycle time as short as 20 ns per 4-bit word.

These features make the 4405x Series ideally suited for high-bandwidth graphics, digital signal processing, high-performance computing systems, and peripheral applications.

The 4405x Series is packaged in a 24-pin 300-mil SOJ with JEDEC standard pinouts.

PRODUCT SERIES OVERVIEW

Part No.	Refresh	Voltage
IS41C44052	2K	5V \pm 10%
IS41C44054	4K	5V \pm 10%
IS41LV44052	2K	3.3V \pm 10%
IS41LV44054	4K	3.3V \pm 10%

KEY TIMING PARAMETERS

Parameter	-50	-60	Unit
RAS Access Time (t_{RAC})	50	60	ns
CAS Access Time (t_{CAC})	13	15	ns
Column Address Access Time (t_{AA})	25	30	ns
Fast Page Mode Cycle Time (t_{PC})	20	25	ns
Read/Write Cycle Time (t_{RC})	84	104	ns

PIN CONFIGURATION

24 (26) Pin SOJ

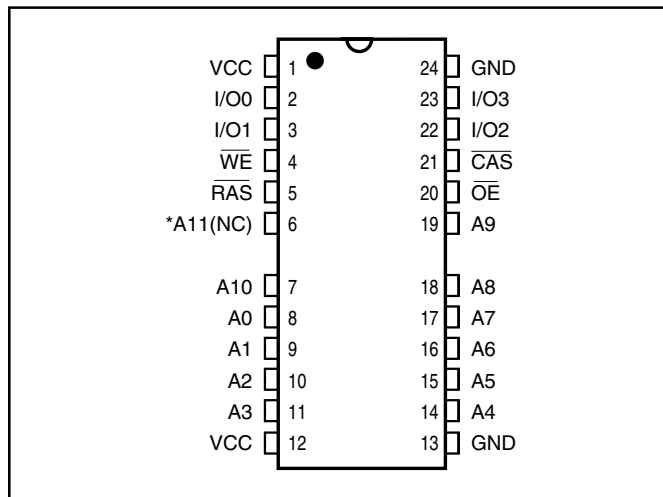

* A11 is NC for 2K Refresh devices.

PIN DESCRIPTIONS

A0-A11	Address Inputs (4K Refresh)
A0-A10	Address Inputs (2K Refresh)
I/O0-3	Data Inputs/Outputs
$\overline{\text{WE}}$	Write Enable
$\overline{\text{OE}}$	Output Enable
$\overline{\text{RAS}}$	Row Address Strobe
$\overline{\text{CAS}}$	Column Address Strobe
Vcc	Power
GND	Ground
NC	No Connection

ISSI reserves the right to make changes to its products at any time without notice in order to improve design and supply the best possible product. We assume no responsibility for any errors which may appear in this publication. © Copyright 2001, Integrated Silicon Solution, Inc.

FUNCTIONAL BLOCK DIAGRAM

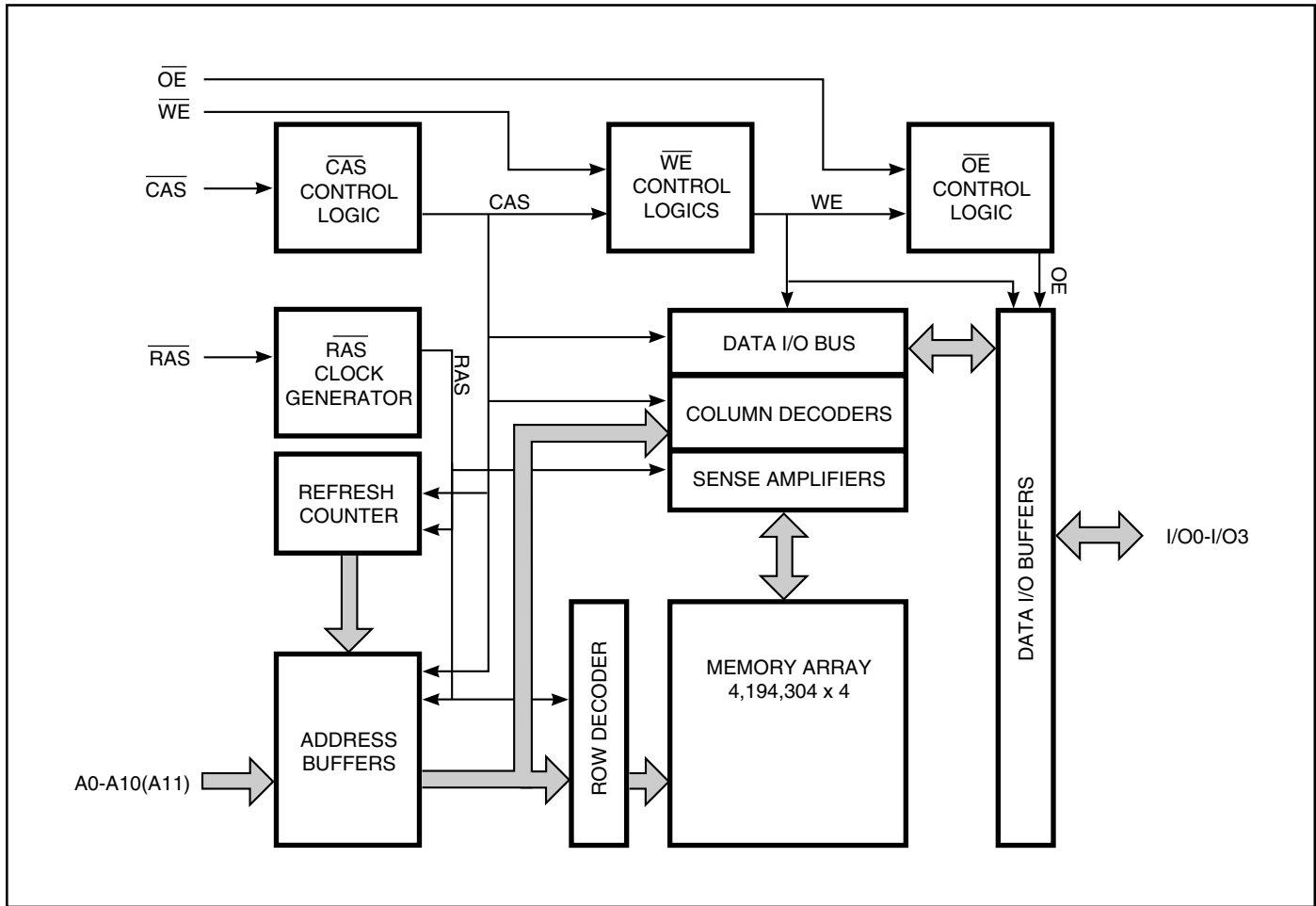

TRUTH TABLE

Function	$\overline{\text{RAS}}$	$\overline{\text{CAS}}$	$\overline{\text{WE}}$	$\overline{\text{OE}}$	Address $t_{\text{R}}/t_{\text{C}}$	I/O	
Standby	H	H	X	X	X	High-Z	
Read	L	L	H	L	ROW/COL	DOUT	
Write: Word (Early Write)	L	L	L	X	ROW/COL	DIN	
Read-Write	L	L	H→L	L→H	ROW/COL	DOUT, DIN	
Hidden Refresh	Read	L→H→L	L	H	L	ROW/COL	DOUT
	Write ⁽¹⁾	L→H→L	L	L	X	ROW/COL	DOUT
$\overline{\text{RAS}}$ -Only Refresh	H→L	H	X	X	ROW/NA	High-Z	
CBR Refresh	H→L	L	X	X	X	High-Z	

Note:
1. EARLY WRITE only.

Functional Description

The IS41C4405x and IS41LV4405x are CMOS DRAMs optimized for high-speed bandwidth, low power applications. During READ or WRITE cycles, each bit is uniquely addressed through the 11 or 12 address bits. These are entered 11 bits (A0-A10) at a time for the 2K refresh device or 12 bits (A0-A11) at a time for the 4K refresh device. The row address is latched by the Row Address Strobe ($\overline{\text{RAS}}$). The column address is latched by the Column Address Strobe ($\overline{\text{CAS}}$). $\overline{\text{RAS}}$ is used to latch the first nine bits and $\overline{\text{CAS}}$ is used the latter ten bits.

Memory Cycle

A memory cycle is initiated by bring $\overline{\text{RAS}}$ LOW and it is terminated by returning both $\overline{\text{RAS}}$ and $\overline{\text{CAS}}$ HIGH. To ensure proper device operation and data integrity any memory cycle, once initiated, must not be ended or aborted before the minimum t_{RAS} time has expired. A new cycle must not be initiated until the minimum precharge time t_{RP} , t_{CP} has elapsed.

Read Cycle

A read cycle is initiated by the falling edge of $\overline{\text{CAS}}$ or $\overline{\text{OE}}$, whichever occurs last, while holding $\overline{\text{WE}}$ HIGH. The column address must be held for a minimum time specified by t_{AR} . Data Out becomes valid only when t_{RAC} , t_{AA} , t_{CAC} and t_{OEA} are all satisfied. As a result, the access time is dependent on the timing relationships between these parameters.

Write Cycle

A write cycle is initiated by the falling edge of $\overline{\text{CAS}}$ and $\overline{\text{WE}}$, whichever occurs last. The input data must be valid at or before the falling edge of $\overline{\text{CAS}}$ or $\overline{\text{WE}}$, whichever occurs last.

Auto Refresh Cycle

To retain data, 2,048 refresh cycles are required in each 32 ms period, or 4,096 refresh cycles are required in each 64ms period. There are two ways to refresh the memory:

1. By clocking each of the 2,048 row addresses (A0 through A10) or 4096 row addresses (A0 through A11) with $\overline{\text{RAS}}$ at least once every 32 ms or 64ms respectively. Any read, write, read-modify-write or $\overline{\text{RAS}}$ -only cycle refreshes the addressed row.
2. Using a $\overline{\text{CAS}}$ -before- $\overline{\text{RAS}}$ refresh cycle. $\overline{\text{CAS}}$ -before- $\overline{\text{RAS}}$ refresh is activated by the falling edge of $\overline{\text{RAS}}$, while holding $\overline{\text{CAS}}$ LOW. In $\overline{\text{CAS}}$ -before- $\overline{\text{RAS}}$ refresh cycle, an internal 9-bit counter provides the row addresses and the external address inputs are ignored.

$\overline{\text{CAS}}$ -before- $\overline{\text{RAS}}$ is a refresh-only mode and no data access or device selection is allowed. Thus, the output remains in the High-Z state during the cycle.

Power-On

After application of the V_{CC} supply, an initial pause of 200 μs is required followed by a minimum of eight initialization cycles (any combination of cycles containing a $\overline{\text{RAS}}$ signal).

During power-on, it is recommended that $\overline{\text{RAS}}$ track with V_{CC} or be held at a valid V_{IH} to avoid current surges.

ABSOLUTE MAXIMUM RATINGS⁽¹⁾

Symbol	Parameters		Rating	Unit
V _T	Voltage on Any Pin Relative to GND	5V	-1.0 to +7.0	V
		3.3V	-0.5 to +4.6	
V _{CC}	Supply Voltage	5V	-1.0 to +7.0	V
		3.3V	-0.5 to +4.6	
I _{OUT}	Output Current		50	mA
P _D	Power Dissipation		1	W
T _A	Commercial Operation Temperature		0 to +70	°C
	Industrial Operation Temperature		-40 to +85	
T _{STG}	Storage Temperature		-55 to +125	°C

Note:

1. Stress greater than those listed under ABSOLUTE MAXIMUM RATINGS may cause permanent damage to the device. This is a stress rating only and functional operation of the device at these or any other conditions above those indicated in the operational sections of this specification is not implied. Exposure to absolute maximum rating conditions for extended periods may affect reliability.

RECOMMENDED OPERATING CONDITIONS (Voltages are referenced to GND.)

Symbol	Parameter		Min.	Typ.	Max.	Unit
V _{CC}	Supply Voltage	5V	4.5	5.0	5.5	V
		3.3V	3.0	3.3	3.6	
V _{IH}	Input High Voltage	5V	2.4	—	V _{CC} + 1.0	V
		3.3V	2.0	—	V _{CC} + 0.3	
V _{IL}	Input Low Voltage	5V	-1.0	—	0.8	V
		3.3V	-0.3	—	0.8	
T _A	Commercial Ambient Temperature		0	—	70	°C
	Industrial Ambient Temperature		-40	—	85	°C

CAPACITANCE^(1,2)

Symbol	Parameter	Max.	Unit
C _{IN1}	Input Capacitance: A0-A10(A11)	5	pF
C _{IN2}	Input Capacitance: $\overline{\text{RAS}}$, $\overline{\text{CAS}}$, $\overline{\text{WE}}$, $\overline{\text{OE}}$	7	pF
C _{IO}	Data Input/Output Capacitance: I/O0-I/O3	7	pF

Notes:

1. Tested initially and after any design or process changes that may affect these parameters.
2. Test conditions: T_A = 25°C, f = 1 MHz.

ELECTRICAL CHARACTERISTICS⁽¹⁾

(Recommended Operating Conditions unless otherwise noted.)

Symbol	Parameter	Test Condition	V _{CC}	Speed	Min.	Max.	Unit
I _{IL}	Input Leakage Current	Any input $0V \leq V_{IN} \leq V_{CC}$ Other inputs not under test = 0V			-5	5	μA
I _{IO}	Output Leakage Current	Output is disabled (Hi-Z) $0V \leq V_{OUT} \leq V_{CC}$			-5	5	μA
V _{OH}	Output High Voltage Level	I _{OH} = -5.0 mA, V _{CC} = 5V I _{OH} = -2.0 mA, V _{CC} = 3.3V			2.4	—	V
V _{OL}	Output Low Voltage Level	I _{OL} = 4.2 mA, V _{CC} = 5V I _{OL} = 2 mA, V _{CC} = 3.3V			—	0.4	V
I _{CC1}	Standby Current: TTL	$\overline{RAS}, \overline{CAS} \geq V_{IH}$ Commercial Industrial	5V 3.3V 5V 3.3V		—	2 0.5 3 2	mA
I _{CC2}	Standby Current: CMOS	$\overline{RAS}, \overline{CAS} \geq V_{CC} - 0.2V$	5V 3.3V	—	— 0.5	1	mA
I _{CC3}	Operating Current: Random Read/Write ^(2,3) Average Power Supply Current	$\overline{RAS}, \overline{CAS}$, Address Cycling, t _{RC} = t _{RC} (min.)		-50 -60	— —	120 110	mA
I _{CC4}	Operating Current: Fast Page Mode ^(2,3,4) Average Power Supply Current	$\overline{RAS} = V_{IL}, \overline{CAS} \geq V_{IH}$ t _{RC} = t _{RC} (min.)		-50 -60	— —	90 80	mA
I _{CC4}	Refresh Current: \overline{RAS} -Only ^(2,3) Average Power Supply Current	\overline{RAS} Cycling, $\overline{CAS} \geq V_{IH}$ t _{RC} = t _{RC} (min.)		-50 -60	— —	120 110	mA
I _{CC5}	Refresh Current: CBR ^(2,3,5) Average Power Supply Current	$\overline{RAS}, \overline{CAS}$ Cycling t _{RC} = t _{RC} (min.)		-50 -60	— —	120 110	mA

Notes:

1. An initial pause of 200 μs is required after power-up followed by eight \overline{RAS} refresh cycles (\overline{RAS} -Only or CBR) before proper device operation is assured. The eight \overline{RAS} cycles wake-up should be repeated any time the t_{REF} refresh requirement is exceeded.
2. Dependent on cycle rates.
3. Specified values are obtained with minimum cycle time and the output open.
4. Column-address is changed once each Fast Page cycle.
5. Enables on-chip refresh and address counters.

AC CHARACTERISTICS^(1,2,3,4,5,6)

(Recommended Operating Conditions unless otherwise noted.)

Symbol	Parameter	-50		-60		Units
		Min.	Max.	Min.	Max.	
t _{RC}	Random READ or WRITE Cycle Time	84	—	104	—	ns
t _{RAC}	Access Time from $\overline{\text{RAS}}$ ^(6, 7)	—	50	—	60	ns
t _{CAC}	Access Time from $\overline{\text{CAS}}$ ^(6, 8, 15)	—	13	—	15	ns
t _{AA}	Access Time from Column-Address ⁽⁶⁾	—	25	—	30	ns
t _{RAS}	$\overline{\text{RAS}}$ Pulse Width	50	10K	60	10K	ns
t _{RP}	$\overline{\text{RAS}}$ Precharge Time	30	—	40	—	ns
t _{CAS}	$\overline{\text{CAS}}$ Pulse Width ⁽²³⁾	8	10K	10	10K	ns
t _{CP}	$\overline{\text{CAS}}$ Precharge Time ⁽⁹⁾	9	—	9	—	ns
t _{CSH}	$\overline{\text{CAS}}$ Hold Time ⁽²¹⁾	38	—	40	—	ns
t _{RCd}	$\overline{\text{RAS}}$ to $\overline{\text{CAS}}$ Delay Time ^(10, 20)	12	37	14	45	ns
t _{ASR}	Row-Address Setup Time	0	—	0	—	ns
t _{RAH}	Row-Address Hold Time	8	—	10	—	ns
t _{ASC}	Column-Address Setup Time ⁽²⁰⁾	0	—	0	—	ns
t _{CAH}	Column-Address Hold Time ⁽²⁰⁾	8	—	10	—	ns
t _{AR}	Column-Address Hold Time (referenced to $\overline{\text{RAS}}$)	30	—	40	—	ns
t _{RAD}	$\overline{\text{RAS}}$ to Column-Address Delay Time ⁽¹¹⁾	10	25	12	30	ns
t _{RAL}	Column-Address to $\overline{\text{RAS}}$ Lead Time	25	—	30	—	ns
t _{RPC}	$\overline{\text{RAS}}$ to $\overline{\text{CAS}}$ Precharge Time	5	—	5	—	ns
t _{RSH}	$\overline{\text{RAS}}$ Hold Time	8	—	10	—	ns
t _{RHCP}	$\overline{\text{RAS}}$ Hold Time from $\overline{\text{CAS}}$ Precharge	30	—	35	—	ns
t _{CLZ}	$\overline{\text{CAS}}$ to Output in Low-Z ^(15, 24)	0	—	0	—	ns
t _{CRP}	$\overline{\text{CAS}}$ to $\overline{\text{RAS}}$ Precharge Time ⁽²¹⁾	5	—	5	—	ns
t _{OD}	Output Disable Time ^(19, 24)	3	15	3	15	ns
t _{OE}	Output Enable Time ^(15, 16)	—	12	—	15	ns
t _{OE d}	Output Enable Data Delay (Write)	12	—	15	—	ns
t _{OEHC}	$\overline{\text{OE}}$ HIGH Hold Time from $\overline{\text{CAS}}$ HIGH	5	—	5	—	ns
t _{OE p}	$\overline{\text{OE}}$ HIGH Pulse Width	10	—	10	—	ns
t _{OE s}	$\overline{\text{OE}}$ LOW to $\overline{\text{CAS}}$ HIGH Setup Time	5	—	5	—	ns
t _{RCS}	Read Command Setup Time ^(17, 20)	0	—	0	—	ns
t _{RRH}	Read Command Hold Time (referenced to $\overline{\text{RAS}}$) ⁽¹²⁾	0	—	0	—	ns
t _{RCH}	Read Command Hold Time (referenced to $\overline{\text{CAS}}$) ^(12, 17, 21)	0	—	0	—	ns
t _{WCH}	Write Command Hold Time ⁽¹⁷⁾	8	—	10	—	ns
t _{WCR}	Write Command Hold Time (referenced to $\overline{\text{RAS}}$) ⁽¹⁷⁾	40	—	50	—	ns
t _{WP}	Write Command Pulse Width ⁽¹⁷⁾	8	—	10	—	ns
t _{WPZ}	$\overline{\text{WE}}$ Pulse Widths to Disable Outputs	7	—	7	—	ns

AC CHARACTERISTICS (Continued)^(1,2,3,4,5,6)

(Recommended Operating Conditions unless otherwise noted.)

Symbol	Parameter	-50		-60		Units
		Min.	Max.	Min.	Max.	
tRWL	Write Command to $\overline{\text{RAS}}$ Lead Time ⁽¹⁷⁾	13	—	15	—	ns
tCWL	Write Command to $\overline{\text{CAS}}$ Lead Time ^(17, 21)	8	—	10	—	ns
twCS	Write Command Setup Time ^(14, 17, 20)	0	—	0	—	ns
tDHR	Data-in Hold Time (referenced to $\overline{\text{RAS}}$)	39	—	39	—	ns
tACH	Column-Address Setup Time to $\overline{\text{CAS}}$ Precharge during WRITE Cycle	15	—	15	—	ns
toEH	$\overline{\text{OE}}$ Hold Time from $\overline{\text{WE}}$ during READ-MODIFY-WRITE cycle ⁽¹⁸⁾	8	—	10	—	ns
tDS	Data-In Setup Time ^(15, 22)	0	—	0	—	ns
tDH	Data-In Hold Time ^(15, 22)	8	—	10	—	ns
tRWC	READ-MODIFY-WRITE Cycle Time	108	—	133	—	ns
tRWD	$\overline{\text{RAS}}$ to $\overline{\text{WE}}$ Delay Time during READ-MODIFY-WRITE Cycle ⁽¹⁴⁾	64	—	77	—	ns
tCWD	$\overline{\text{CAS}}$ to $\overline{\text{WE}}$ Delay Time ^(14, 20)	26	—	32	—	ns
tAWD	Column-Address to $\overline{\text{WE}}$ Delay Time ⁽¹⁴⁾	39	—	47	—	ns
tPC	Fast Page Mode READ or WRITE Cycle Time	20	—	25	—	ns
tRASP	$\overline{\text{RAS}}$ Pulse Width	50	100K	60	100K	ns
tCPA	Access Time from $\overline{\text{CAS}}$ Precharge ⁽¹⁵⁾	—	30	—	35	ns
tPRWC	READ-WRITE Cycle Time ⁽²⁴⁾	56	—	68	—	ns
tCOH	Data Output Hold after $\overline{\text{CAS}}$ LOW	5	—	5	—	ns
toFF	Output Buffer Turn-Off Delay from $\overline{\text{CAS}}$ or $\overline{\text{RAS}}$ ^(13,15,19, 24)	0	12	0	15	ns
tWHZ	Output Disable Delay from $\overline{\text{WE}}$	3	10	3	10	ns
tCSR	$\overline{\text{CAS}}$ Setup Time (CBR REFRESH) ^(20, 25)	5	—	5	—	ns
tCHR	$\overline{\text{CAS}}$ Hold Time (CBR REFRESH) ^(21, 25)	8	—	10	—	ns
tORD	$\overline{\text{OE}}$ Setup Time prior to $\overline{\text{RAS}}$ during HIDDEN REFRESH Cycle	0	—	0	—	ns
tREF	Auto Refresh Period	2,048 Cycles	—	32	—	ms
		4,096 Cycles	—	64	—	ms
t _r	Transition Time (Rise or Fall) ^(2, 3)	1	50	1	50	ns

AC TEST CONDITIONS

Output load: Two TTL Loads and 50 pF ($V_{CC} = 5.0V \pm 10\%$)
 One TTL Load and 50 pF ($V_{CC} = 3.3V \pm 10\%$)

Input timing reference levels: $V_{IH} = 2.4V$, $V_{IL} = 0.8V$ ($V_{CC} = 5.0V \pm 10\%$);
 $V_{IH} = 2.0V$, $V_{IL} = 0.8V$ ($V_{CC} = 3.3V \pm 10\%$)

Output timing reference levels: $V_{OH} = 2.0V$, $V_{OL} = 0.8V$ ($V_{CC} = 5V \pm 10\%$, $3.3V \pm 10\%$)

Notes:

1. An initial pause of 200 μ s is required after power-up followed by eight $\overline{\text{RAS}}$ refresh cycle ($\overline{\text{RAS}}$ -Only or CBR) before proper device operation is assured. The eight $\overline{\text{RAS}}$ cycles wake-up should be repeated any time the t_{REF} refresh requirement is exceeded.
2. V_{IH} (MIN) and V_{IL} (MAX) are reference levels for measuring timing of input signals. Transition times, are measured between V_{IH} and V_{IL} (or between V_{IL} and V_{IH}) and assume to be 1 ns for all inputs.
3. In addition to meeting the transition rate specification, all input signals must transit between V_{IH} and V_{IL} (or between V_{IL} and V_{IH}) in a monotonic manner.
4. If $\overline{\text{CAS}}$ and $\overline{\text{RAS}} = V_{\text{IH}}$, data output is High-Z.
5. If $\overline{\text{CAS}} = V_{\text{IL}}$, data output may contain data from the last valid READ cycle.
6. Measured with a load equivalent to one TTL gate and 50 pF.
7. Assumes that $t_{\text{RCD}} - t_{\text{RCD}} (\text{MAX})$. If t_{RCD} is greater than the maximum recommended value shown in this table, t_{RAC} will increase by the amount that t_{RCD} exceeds the value shown.
8. Assumes that $t_{\text{RCD}} \bullet t_{\text{RCD}} (\text{MAX})$.
9. If $\overline{\text{CAS}}$ is LOW at the falling edge of $\overline{\text{RAS}}$, data out will be maintained from the previous cycle. To initiate a new cycle and clear the data output buffer, $\overline{\text{CAS}}$ and $\overline{\text{RAS}}$ must be pulsed for t_{CP} .
10. Operation with the $t_{\text{RCD}} (\text{MAX})$ limit ensures that $t_{\text{RAC}} (\text{MAX})$ can be met. $t_{\text{RCD}} (\text{MAX})$ is specified as a reference point only; if t_{RCD} is greater than the specified $t_{\text{RCD}} (\text{MAX})$ limit, access time is controlled exclusively by t_{CAC} .
11. Operation within the $t_{\text{RAD}} (\text{MAX})$ limit ensures that $t_{\text{RCD}} (\text{MAX})$ can be met. $t_{\text{RAD}} (\text{MAX})$ is specified as a reference point only; if t_{RAD} is greater than the specified $t_{\text{RAD}} (\text{MAX})$ limit, access time is controlled exclusively by t_{AA} .
12. Either t_{RCH} or t_{RRH} must be satisfied for a READ cycle.
13. $t_{\text{OFF}} (\text{MAX})$ defines the time at which the output achieves the open circuit condition; it is not a reference to V_{OH} or V_{OL} .
14. t_{WCS} , t_{RWD} , t_{AWD} and t_{CWD} are restrictive operating parameters in LATE WRITE and READ-MODIFY-WRITE cycle only. If $t_{\text{WCS}} \bullet t_{\text{WCS}} (\text{MIN})$, the cycle is an EARLY WRITE cycle and the data output will remain open circuit throughout the entire cycle. If $t_{\text{RWD}} \bullet t_{\text{RWD}} (\text{MIN})$, $t_{\text{AWD}} \bullet t_{\text{AWD}} (\text{MIN})$ and $t_{\text{CWD}} \bullet t_{\text{CWD}} (\text{MIN})$, the cycle is a READ-WRITE cycle and the data output will contain data read from the selected cell. If neither of the above conditions is met, the state of I/O (at access time and until $\overline{\text{CAS}}$ and $\overline{\text{RAS}}$ or $\overline{\text{OE}}$ go back to V_{IH}) is indeterminate. $\overline{\text{OE}}$ held HIGH and $\overline{\text{WE}}$ taken LOW after $\overline{\text{CAS}}$ goes LOW result in a LATE WRITE ($\overline{\text{OE}}$ -controlled) cycle.
15. Output parameter (I/O) is referenced to corresponding $\overline{\text{CAS}}$ input.
16. During a READ cycle, if $\overline{\text{OE}}$ is LOW then taken HIGH before $\overline{\text{CAS}}$ goes HIGH, I/O goes open. If $\overline{\text{OE}}$ is tied permanently LOW, a LATE WRITE or READ-MODIFY-WRITE is not possible.
17. Write command is defined as $\overline{\text{WE}}$ going low.
18. LATE WRITE and READ-MODIFY-WRITE cycles must have both t_{OD} and $t_{\text{OE}} (\text{HIGH})$ met ($\overline{\text{OE}}$ HIGH during WRITE cycle) in order to ensure that the output buffers will be open during the WRITE cycle. The I/Os will provide the previously written data if $\overline{\text{CAS}}$ remains LOW and $\overline{\text{OE}}$ is taken back to LOW after $t_{\text{OE}} (\text{HIGH})$ is met.
19. The I/Os are in open during READ cycles once t_{OD} or t_{OFF} occur.
20. Determined by falling edge of $\overline{\text{CAS}}$.
21. Determined by rising edge of $\overline{\text{CAS}}$.
22. These parameters are referenced to $\overline{\text{CAS}}$ leading edge in EARLY WRITE cycles and $\overline{\text{WE}}$ leading edge in LATE WRITE or READ-MODIFY-WRITE cycles.
23. $\overline{\text{CAS}}$ must meet minimum pulse width.
24. The 3 ns minimum is a parameter guaranteed by design.
25. Enables on-chip refresh and address counters.

FAST-PAGE-MODE READ CYCLE

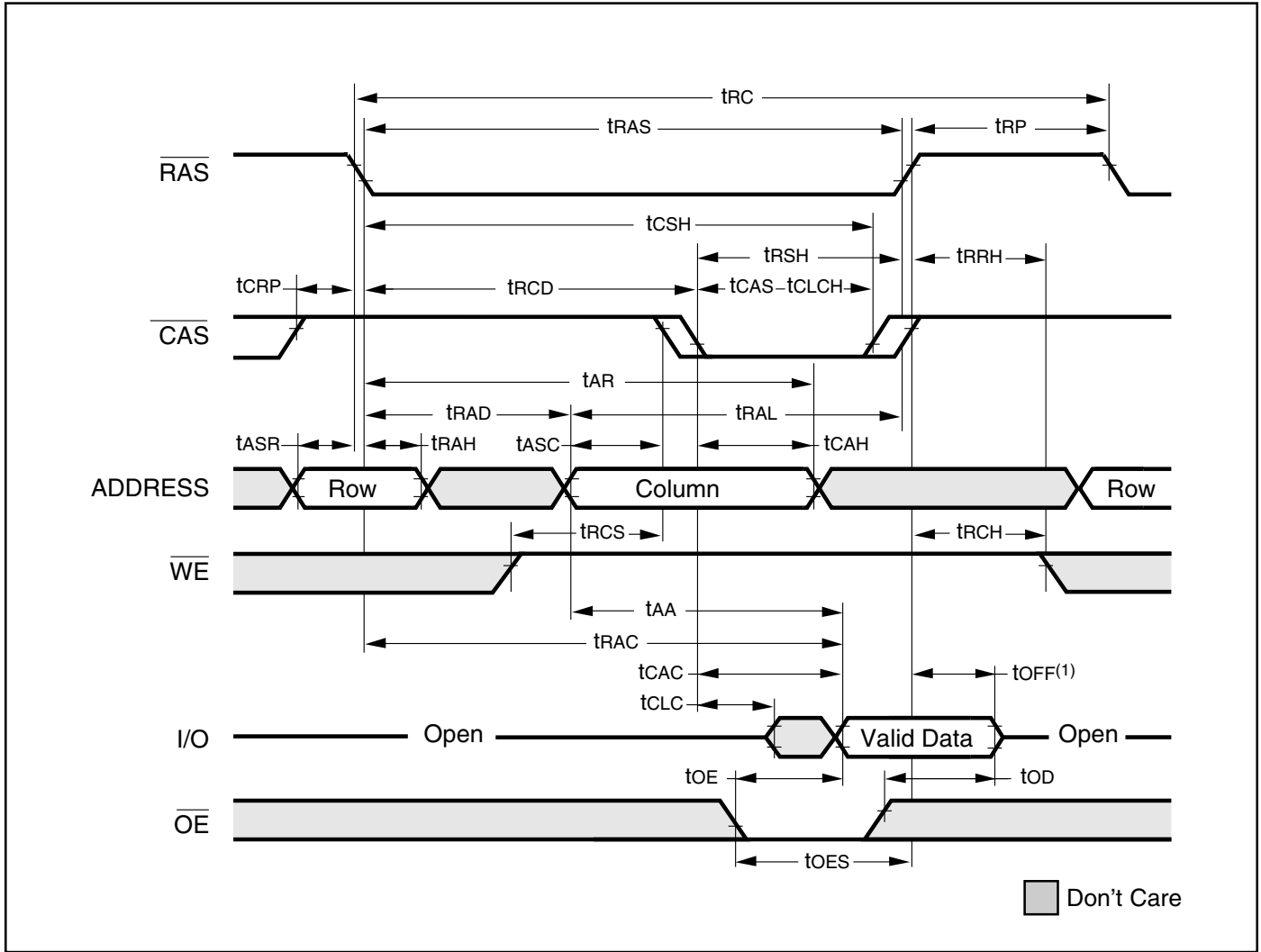

FAST PAGE MODE READ-MODIFY-WRITE CYCLE

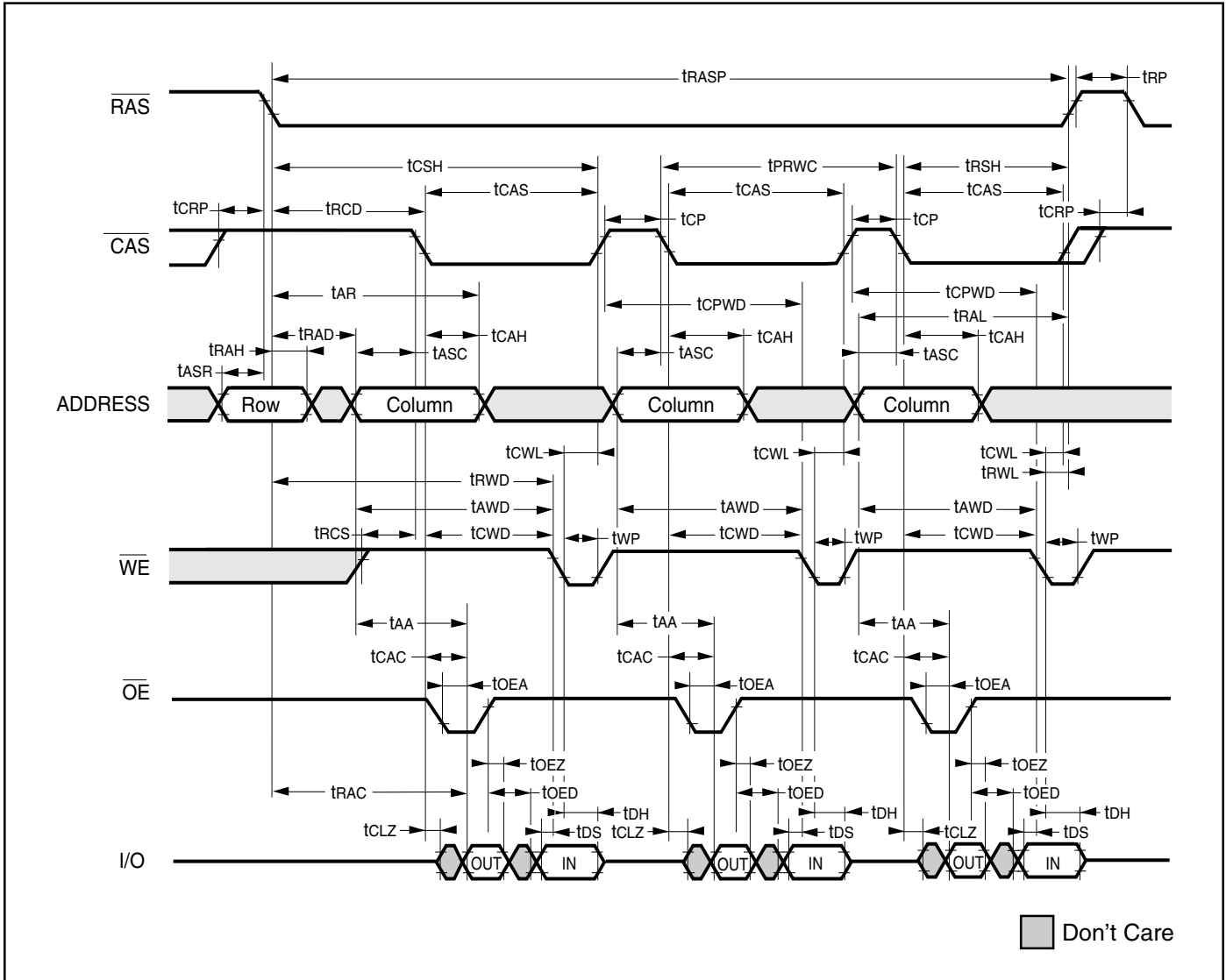

FAST-PAGE-MODE EARLY WRITE CYCLE (\overline{OE} = DON'T CARE)

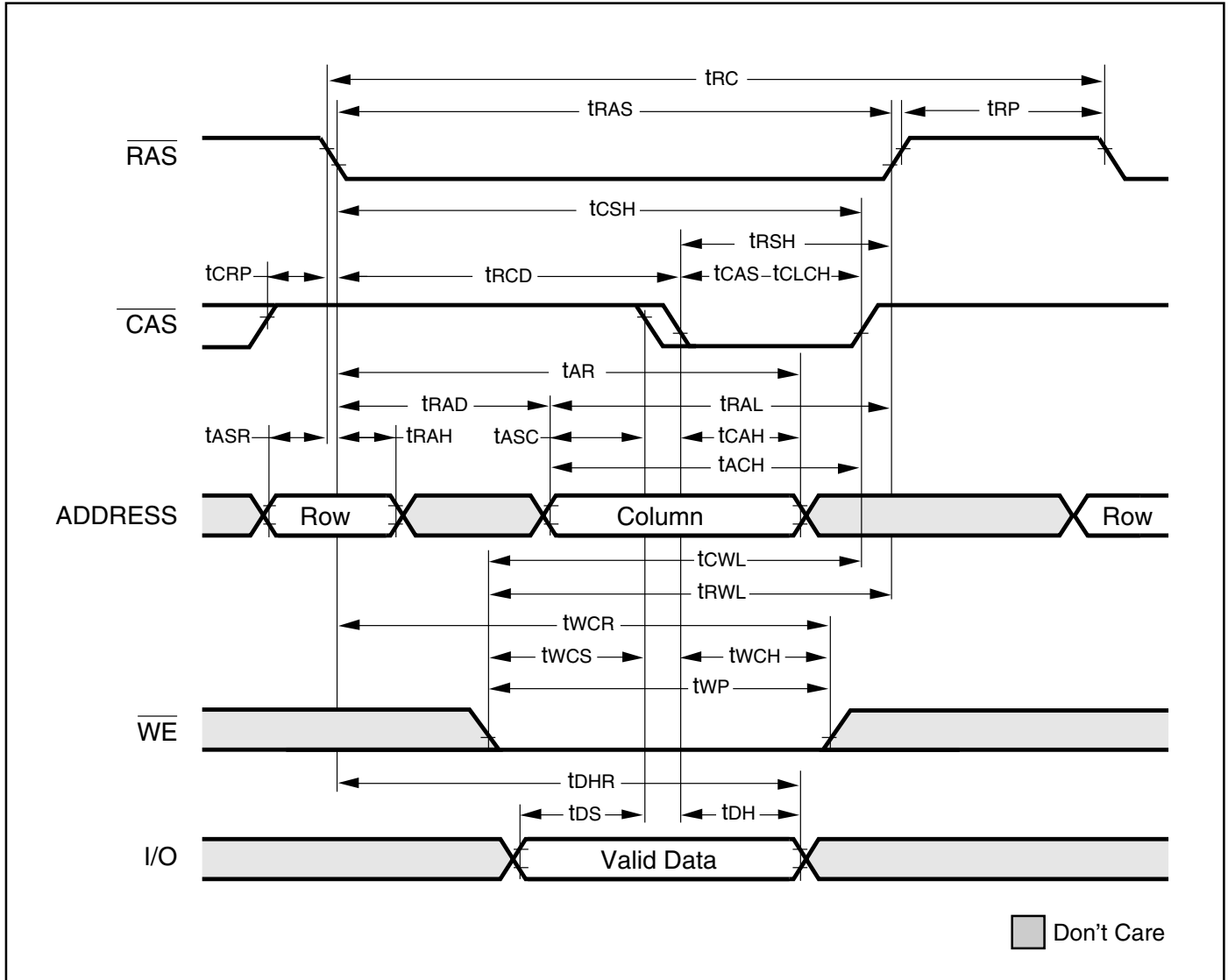

FAST-PAGE-MODE READ WRITE CYCLE (LATE WRITE and READ-MODIFY-WRITE Cycles)

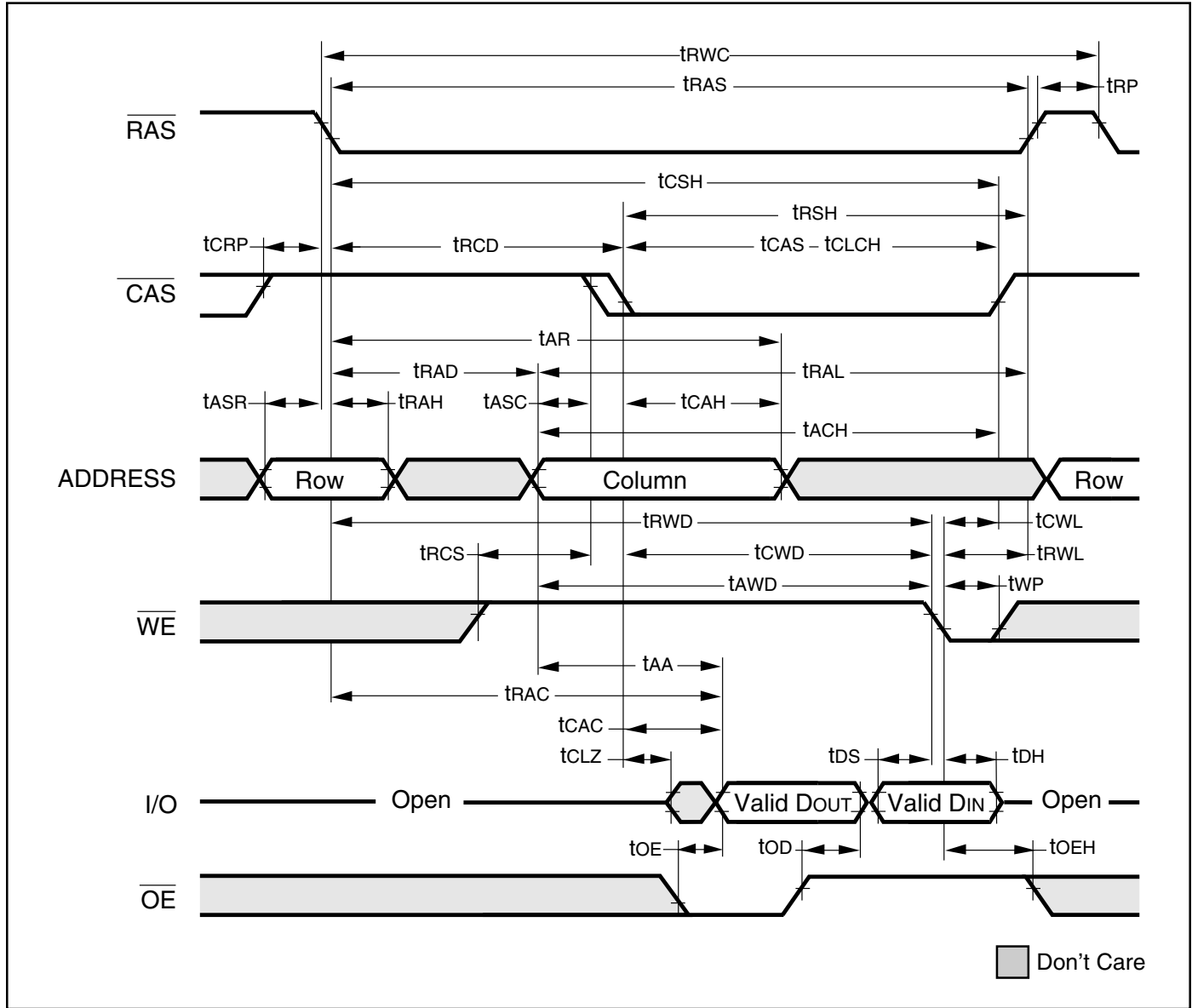

FAST PAGE MODE EARLY WRITE CYCLE

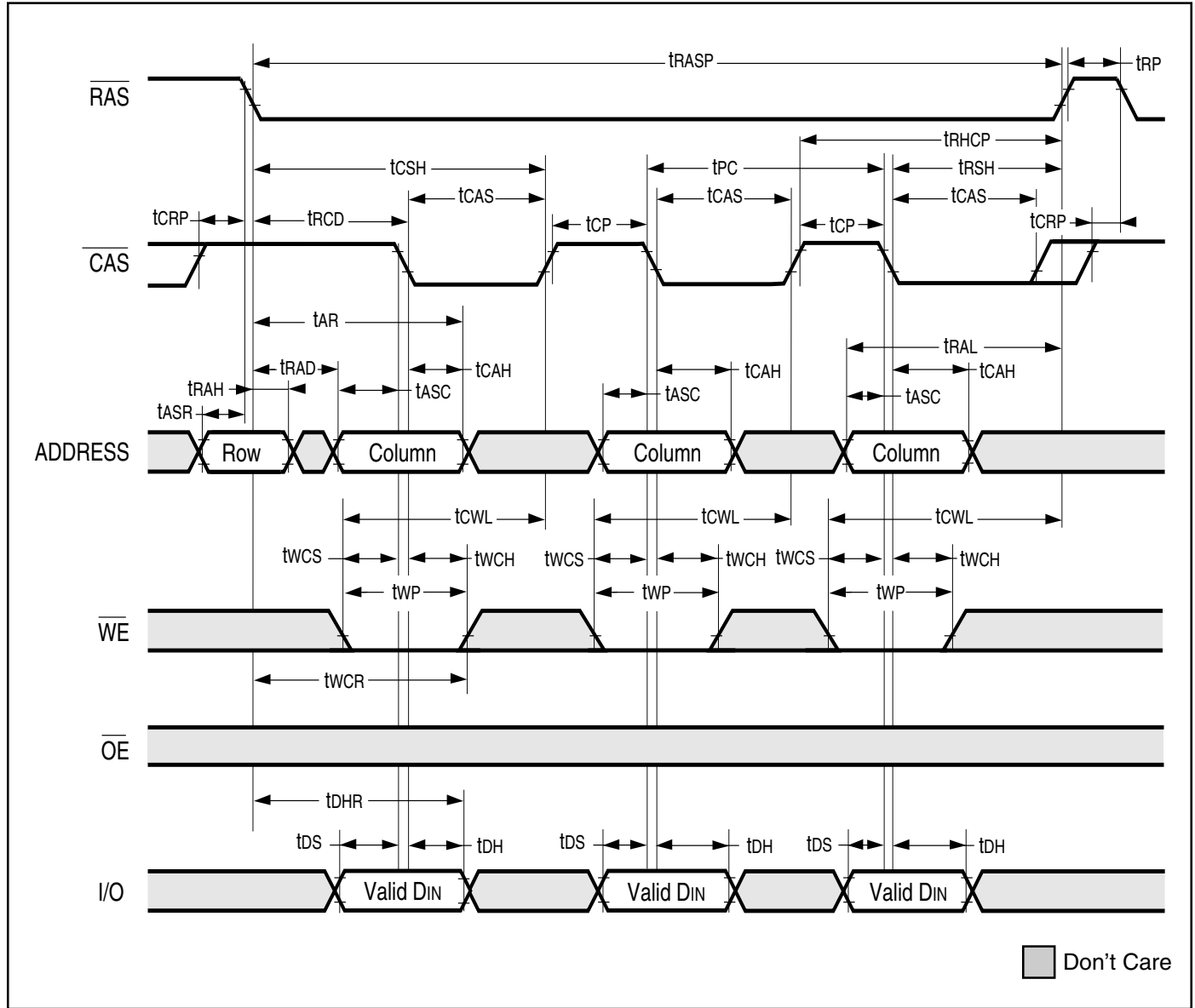

AC WAVEFORMS

READ CYCLE (With \overline{WE} -Controlled Disable)

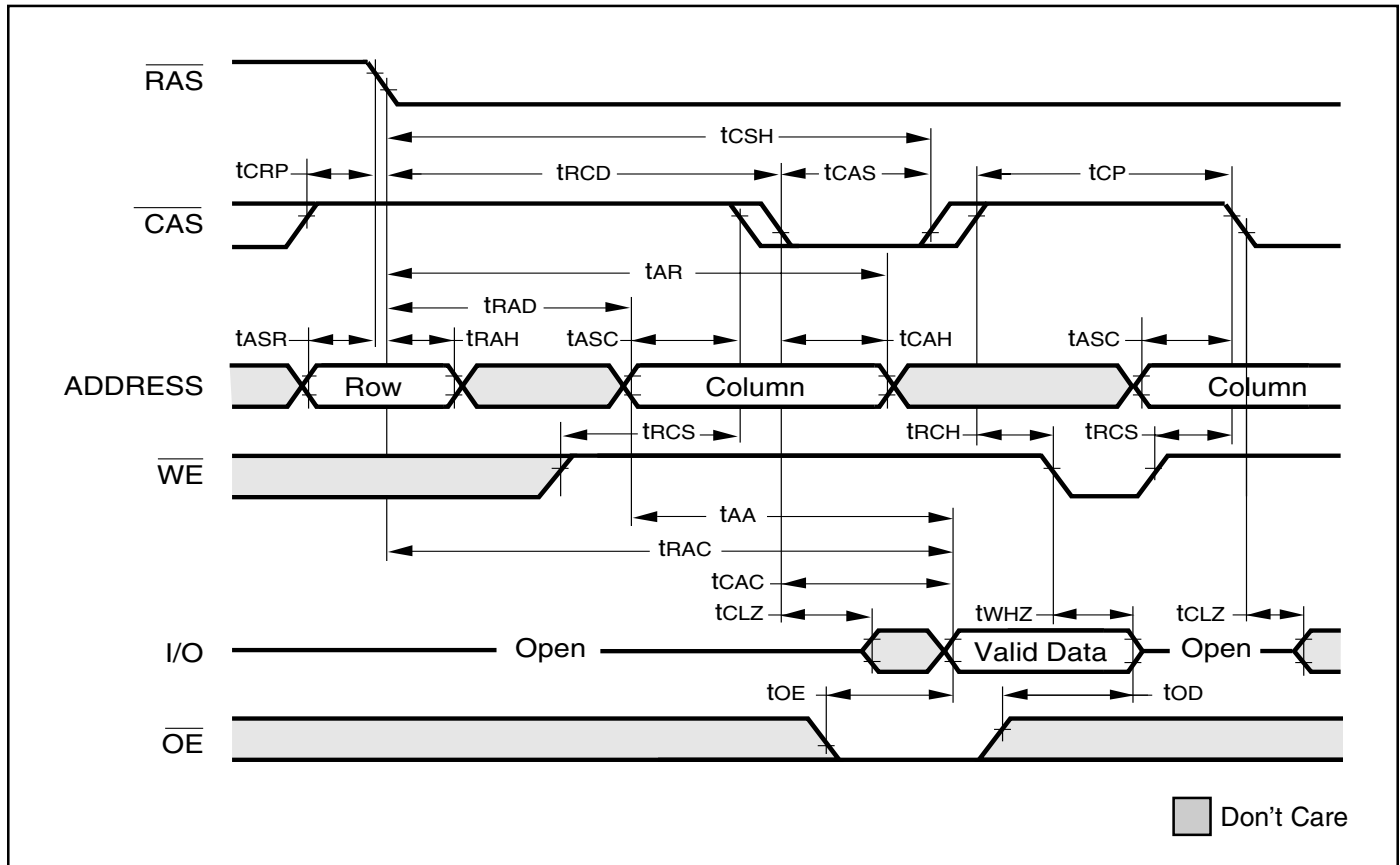

RAS-ONLY REFRESH CYCLE (\overline{OE} , \overline{WE} = DON'T CARE)

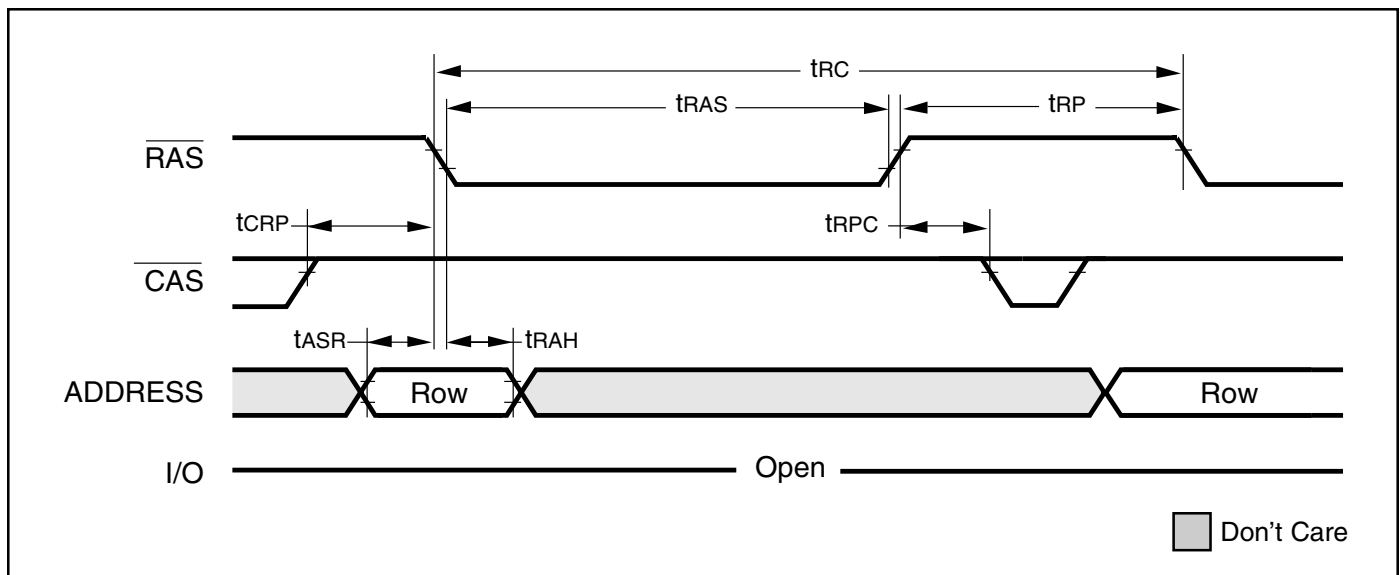

$\overline{\text{CBR}}$ REFRESH CYCLE (Addresses; $\overline{\text{WE}}$, $\overline{\text{OE}}$ = DON'T CARE)

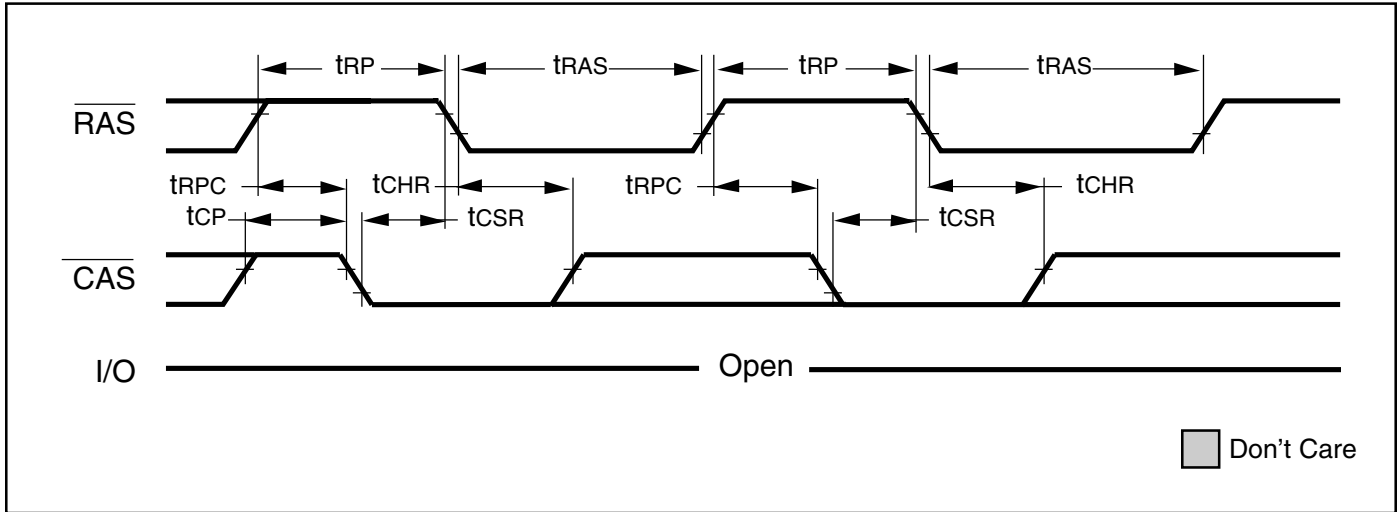

HIDDEN REFRESH CYCLE⁽¹⁾ ($\overline{\text{WE}}$ = HIGH; $\overline{\text{OE}}$ = LOW)

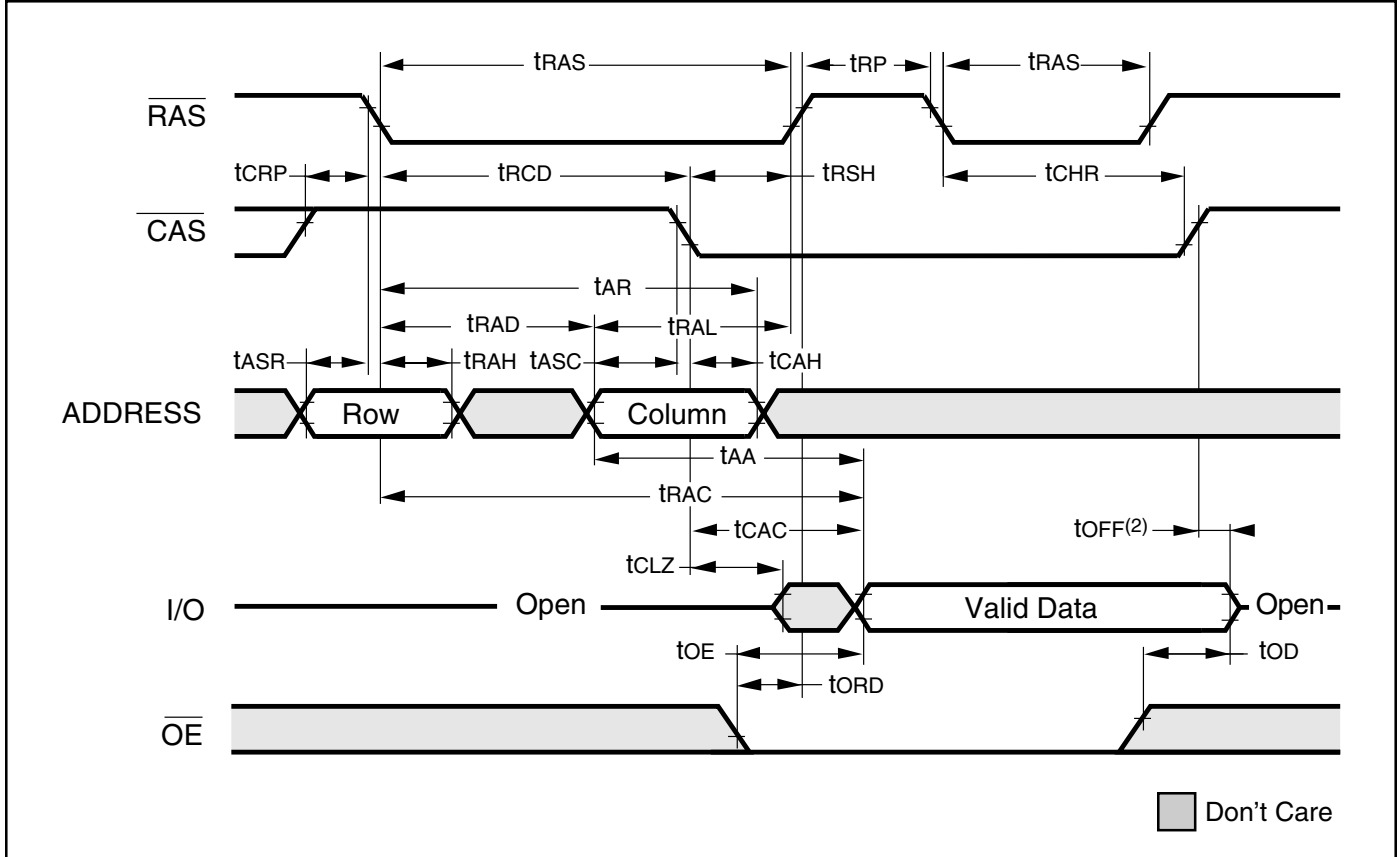

ORDERING INFORMATION

Commercial Range: 0°C to 70°C

Voltage: 5V

Speed (ns)	Order Part No.	Refresh	Package
50	IS41C44052-50J	2K	300-mil SOJ
60	IS41C44052-60J	2K	300-mil SOJ

Speed (ns)	Order Part No.	Refresh	Package
50	IS41C44054-50J	4K	300-mil SOJ
60	IS41C44054-60J	4K	300-mil SOJ

Voltage: 3.3V

Speed (ns)	Order Part No.	Refresh	Package
50	IS41LV44052-50J	2K	300-mil SOJ
60	IS41LV44052-60J	2K	300-mil SOJ

Speed (ns)	Order Part No.	Refresh	Package
50	IS41LV44054-50J	4K	300-mil SOJ
60	IS41LV44054-60J	4K	300-mil SOJ

ORDERING INFORMATION

Industrial Range: -40°C to 85°C

Voltage: 5V

Speed (ns)	Order Part No.	Refresh	Package
50	IS41C44052-50JI	2K	300-mil SOJ
60	IS41C44052-60JI	2K	300-mil SOJ

Speed (ns)	Order Part No.	Refresh	Package
50	IS41C44054-50JI	4K	300-mil SOJ
60	IS41C44054-60JI	4K	300-mil SOJ

Voltage: 3.3V

Speed (ns)	Order Part No.	Refresh	Package
50	IS41LV44052-50JI	2K	300-mil SOJ
60	IS41LV44052-60JI	2K	300-mil SOJ

Speed (ns)	Order Part No.	Refresh	Package
50	IS41LV44054-50JI	4K	300-mil SOJ
60	IS41LV44054-60JI	4K	300-mil SOJ



Integrated Silicon Solution, Inc.

2231 Lawson Lane
Santa Clara, CA 95054
Tel: 1-800-379-4774
Fax: (408) 588-0806
E-mail: sales@issi.com
www.issi.com