

FEATURES

- High-speed access time: 35, 45, 55, 70 ns
- Low active power: 450 mW (typical)
- Low standby power: 500 μ W (typical) CMOS standby
- Output Enable (\overline{OE}) and two Chip Enable ($\overline{CE1}$ and $\overline{CE2}$) inputs for ease in applications
- Fully static operation: no clock or refresh required
- TTL compatible inputs and outputs
- Single 5V ($\pm 10\%$) power supply

DESCRIPTION

The *ISSI* IS62C1024 is a low power, 131,072-word by 8-bit CMOS static RAM. It is fabricated using *ISSI*'s high-performance CMOS technology. This highly reliable process coupled with innovative circuit design techniques, yields higher performance and low power consumption devices.

When $\overline{CE1}$ is HIGH or $\overline{CE2}$ is LOW (deselected), the device assumes a standby mode at which the power dissipation can be reduced by using CMOS input levels.

Easy memory expansion is provided by using two Chip Enable inputs, $\overline{CE1}$ and $\overline{CE2}$. The active LOW Write Enable (\overline{WE}) controls both writing and reading of the memory.

The IS62C1024 is available in 32-pin 525-mil plastic SOP and TSOP (type 1) packages.

FUNCTIONAL BLOCK DIAGRAM

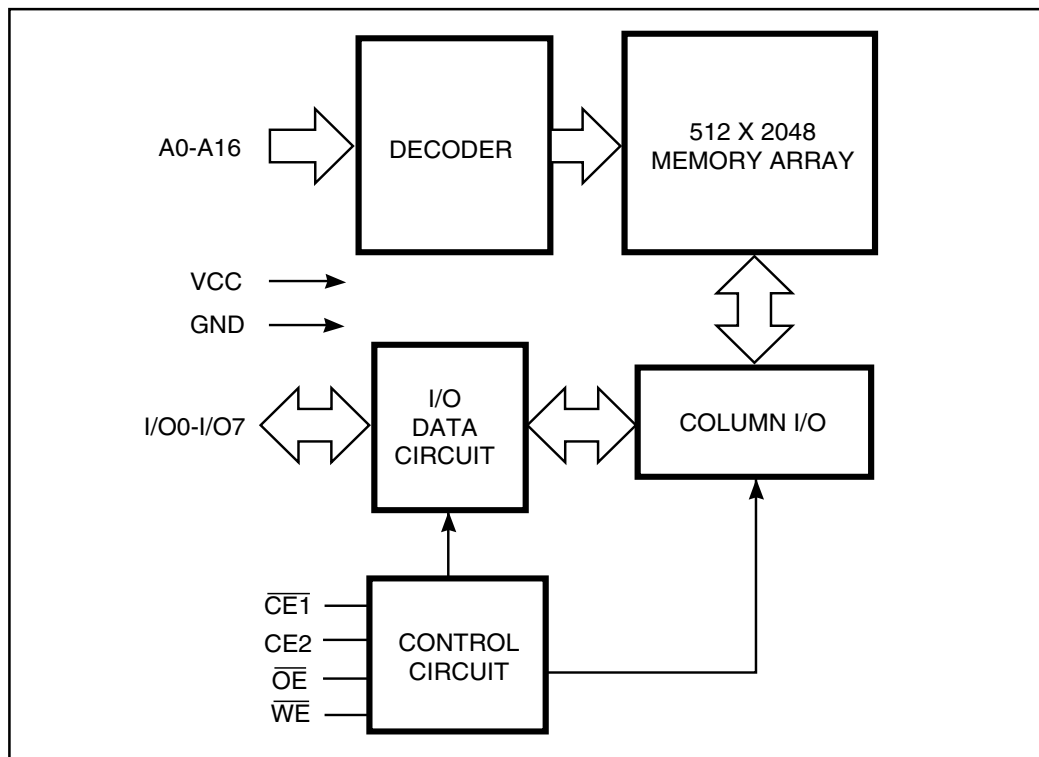

ISSI reserves the right to make changes to its products at any time without notice in order to improve design and supply the best possible product. We assume no responsibility for any errors which may appear in this publication. © Copyright 2000, Integrated Silicon Solution, Inc.

PIN CONFIGURATION

32-Pin SOP

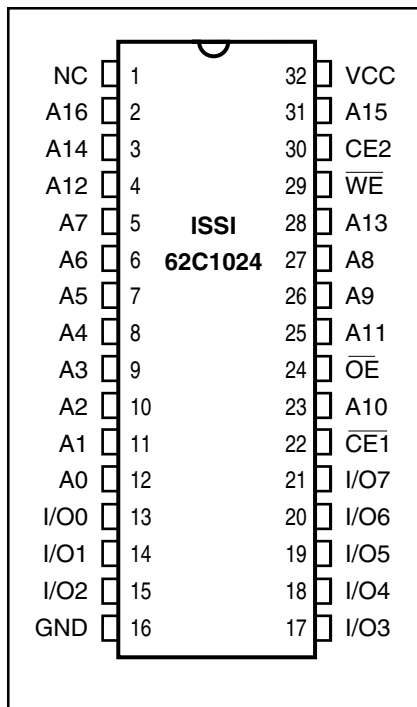

32-Pin TSOP (Type 1)

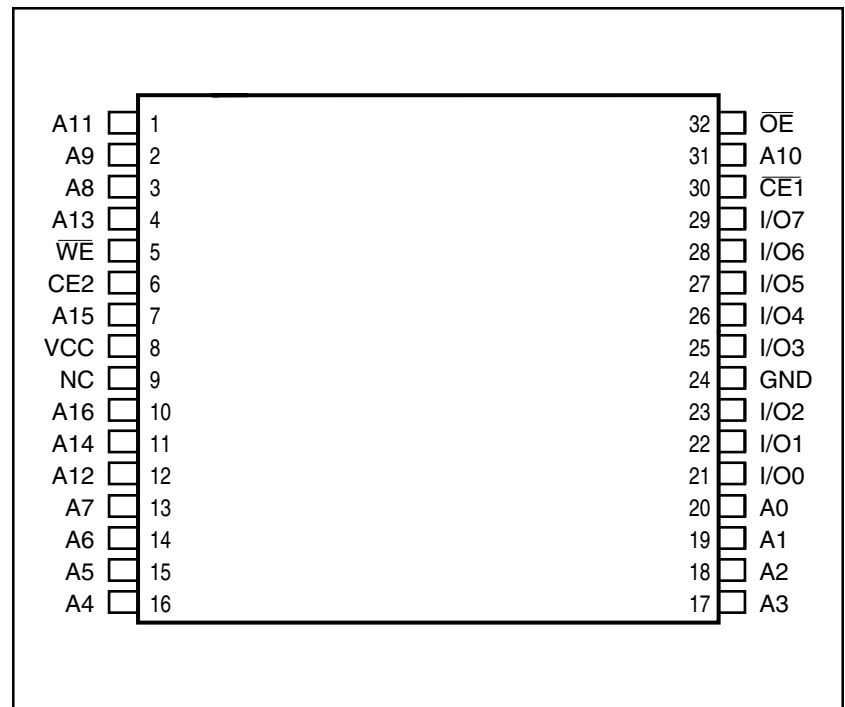

PIN DESCRIPTIONS

A0-A16	Address Inputs
$\overline{CE1}$	Chip Enable 1 Input
CE2	Chip Enable 2 Input
\overline{OE}	Output Enable Input
\overline{WE}	Write Enable Input
I/O0-I/O7	Input/Output
Vcc	Power
GND	Ground

OPERATING RANGE

Range	Ambient Temperature	Vcc
Commercial	0°C to +70°C	5V ± 10%
Industrial	-40°C to +85°C	5V ± 10%

TRUTH TABLE

Mode	\overline{WE}	$\overline{CE1}$	CE2	\overline{OE}	I/O Operation	Vcc Current
Not Selected	X	H	X	X	High-Z	I _{SB1} , I _{SB2}
(Power-down)	X	X	L	X	High-Z	I _{SB1} , I _{SB2}
Output Disabled	H	L	H	H	High-Z	I _{CC}
Read	H	L	H	L	D _{OUT}	I _{CC}
Write	L	L	H	X	D _{IN}	I _{CC}

ABSOLUTE MAXIMUM RATINGS⁽¹⁾

Symbol	Parameter	Value	Unit
V _{TERM}	Terminal Voltage with Respect to GND	-0.5 to +7.0	V
T _{BIAS}	Temperature Under Bias	-10 to +85	°C
T _{STG}	Storage Temperature	-65 to +150	°C
P _T	Power Dissipation	1.5	W
I _{OUT}	DC Output Current (LOW)	20	mA

Notes:

1. Stress greater than those listed under ABSOLUTE MAXIMUM RATINGS may cause permanent damage to the device. This is a stress rating only and functional operation of the device at these or any other conditions above those indicated in the operational sections of this specification is not implied. Exposure to absolute maximum rating conditions for extended periods may affect reliability.

CAPACITANCE^(1,2)

Symbol	Parameter	Conditions	Max.	Unit
C _{IN}	Input Capacitance	V _{IN} = 0V	6	pF
C _{OUT}	Output Capacitance	V _{OUT} = 0V	8	pF

Notes:

1. Tested initially and after any design or process changes that may affect these parameters.
2. Test conditions: T_A = 25°C, f = 1 MHz, V_{CC} = 5.0V.

DC ELECTRICAL CHARACTERISTICS (Over Operating Range)

Symbol	Parameter	Test Conditions	Min.	Max.	Unit
V _{OH}	Output HIGH Voltage	V _{CC} = Min., I _{OH} = -1.0 mA	2.4	—	V
V _{OL}	Output LOW Voltage	V _{CC} = Min., I _{OL} = 2.1 mA	—	0.4	V
V _{IH}	Input HIGH Voltage		2.2	V _{CC} + 0.5	V
V _{IL}	Input LOW Voltage ⁽¹⁾		-0.3	0.8	V
I _{LI}	Input Leakage	GND ≤ V _{IN} ≤ V _{CC}	Com. Ind.	-5 5	μA
I _{LO}	Output Leakage	GND ≤ V _{OUT} ≤ V _{CC}	Com. Ind.	-5 5	μA

Notes:

1. V_{IL} = -3.0V for pulse width less than 10 ns.

POWER SUPPLY CHARACTERISTICS⁽¹⁾ (Over Operating Range)

Symbol	Parameter	Test Conditions		-35		-45		-55		-70		Unit
				Min.	Max.	Min.	Max.	Min.	Max.	Min.	Max.	
I _{CC}	V _{CC} Dynamic Operating Supply Current	V _{CC} = Max., $\overline{CE} = V_{IL}$ I _{OUT} = 0 mA, f = f _{MAX}	Com. Ind.	— —	150 160	— —	135 145	— —	120 130	— —	90 100	mA
I _{SB1}	TTL Standby Current (TTL Inputs)	V _{CC} = Max., V _{IN} = V _{IH} or V _{IL} , $\overline{CE1} \geq V_{IH}$, or CE2 ≤ V _{IL} , f = 0	Com. Ind.	— —	40 60	— —	40 60	— —	40 60	— —	40 60	mA
I _{SB2}	CMOS Standby Current (CMOS Inputs)	V _{CC} = Max., CE1 ≤ V _{CC} - 0.2V, CE2 ≤ 0.2V, V _{IN} ≥ V _{CC} - 0.2V, or V _{IN} ≤ 0.2V, f = 0	Com. Ind.	— —	30 40	— —	30 40	— —	30 40	— —	30 40	mA

Notes:

1. At f = f_{MAX}, address and data inputs are cycling at the maximum frequency, f = 0 means no input lines change.

AC TEST CONDITIONS

Parameter	Unit
Input Pulse Level	0V to 3.0V
Input Rise and Fall Times	5 ns
Input and Output Timing and Reference Level	1.5V
Output Load	See Figures 1a and 1b

AC TEST LOADS

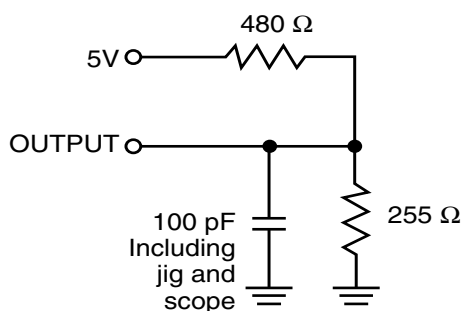

Figure 1a.

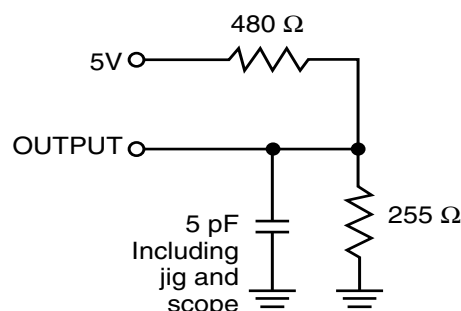

Figure 1b.

READ CYCLE SWITCHING CHARACTERISTICS⁽¹⁾ (Over Operating Range)

Symbol	Parameter	-35		-45		-55		-70		Unit
		Min.	Max.	Min.	Max.	Min.	Max.	Min.	Max.	
t _{RC}	Read Cycle Time	35	—	45	—	55	—	70	—	ns
t _{AA}	Address Access Time	—	35	—	45	—	55	—	70	ns
t _{OHA}	Output Hold Time	3	—	3	—	3	—	3	—	ns
t _{ACE1}	$\overline{\text{CE1}}$ Access Time	—	35	—	45	—	55	—	70	ns
t _{ACE2}	CE2 Access Time	—	35	—	45	—	55	—	70	ns
t _{DOE}	$\overline{\text{OE}}$ Access Time	—	10	—	20	—	25	—	35	ns
t _{LZOE⁽²⁾}	$\overline{\text{OE}}$ to Low-Z Output	0	—	0	—	0	—	0	—	ns
t _{HZOE⁽²⁾}	$\overline{\text{OE}}$ to High-Z Output	0	10	0	15	0	20	0	25	ns
t _{LZCE1⁽²⁾}	$\overline{\text{CE1}}$ to Low-Z Output	3	—	5	—	7	—	10	—	ns
t _{LZCE2⁽²⁾}	CE2 to Low-Z Output	3	—	5	—	7	—	10	—	ns
t _{HZCE⁽²⁾}	$\overline{\text{CE1}}$ or CE2 to High-Z Output	0	10	0	15	0	20	0	25	ns

Notes:

1. Test conditions assume signal transition times of 5 ns or less, timing reference levels of 1.5V, input pulse levels of 0 to 3.0V and output loading specified in Figure 1a.
2. Tested with the load in Figure 1b. Transition is measured ± 500 mV from steady-state voltage. Not 100% tested.

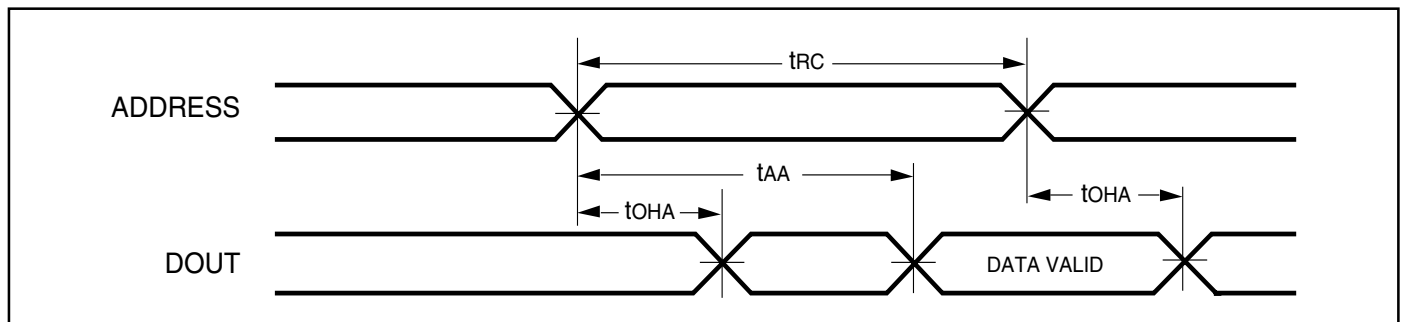
AC WAVEFORMS**READ CYCLE NO. 1^(1,2)**

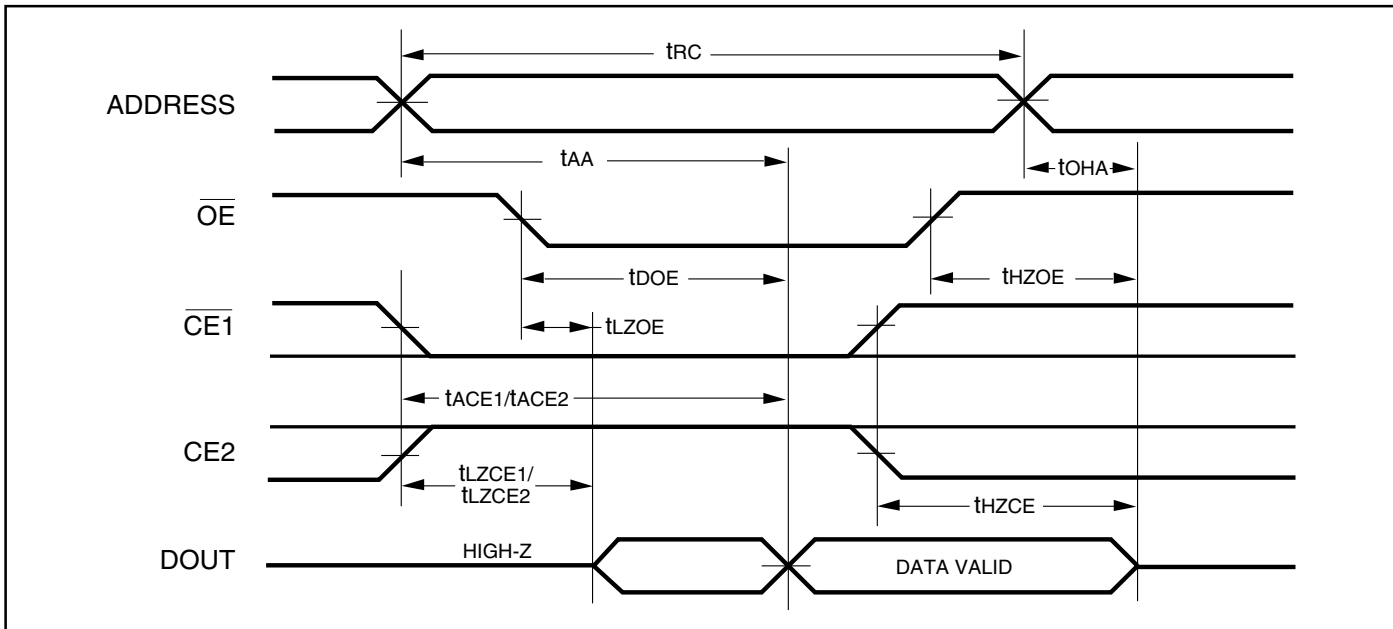
READ CYCLE NO. 2^(1,3)**Notes:**

1. \overline{WE} is HIGH for a Read Cycle.
2. The device is continuously selected. \overline{OE} , $\overline{CE1} = V_{IL}$, $CE2 = V_{IH}$.
3. Address is valid prior to or coincident with $\overline{CE1}$ LOW and $CE2$ HIGH transitions.

WRITE CYCLE SWITCHING CHARACTERISTICS^(1,3) (Over Operating Range, Standard and Low Power)

Symbol	Parameter	-35		-45		-55		-70		Unit
		Min.	Max.	Min.	Max.	Min.	Max.	Min.	Max.	
t_{WC}	Write Cycle Time	35	—	45	—	55	—	70	—	ns
t_{SCE1}	$\overline{CE1}$ to Write End	25	—	35	—	50	—	60	—	ns
t_{SCE2}	$CE2$ to Write End	25	—	35	—	50	—	60	—	ns
t_{AW}	Address Setup Time to Write End	25	—	35	—	45	—	60	—	ns
t_{HA}	Address Hold from Write End	0	—	0	—	0	—	0	—	ns
t_{SA}	Address Setup Time	0	—	0	—	0	—	0	—	ns
$t_{PWE}^{(4)}$	\overline{WE} Pulse Width	25	—	35	—	40	—	50	—	ns
t_{SD}	Data Setup to Write End	20	—	25	—	25	—	30	—	ns
t_{HD}	Data Hold from Write End	0	—	0	—	0	—	0	—	ns
$t_{HZWE}^{(2)}$	\overline{WE} LOW to High-Z Output	—	10	—	15	—	20	—	25	ns
$t_{LZWE}^{(2)}$	\overline{WE} HIGH to Low-Z Output	3	—	5	—	5	—	5	—	ns

Notes:

1. Test conditions assume signal transition times of 5 ns or less, timing reference levels of 1.5V, input pulse levels of 0 to 3.0V and output loading specified in Figure 1a.
2. Tested with the load in Figure 1b. Transition is measured ± 500 mV from steady-state voltage. Not 100% tested.
3. The internal write time is defined by the overlap of $\overline{CE1}$ LOW, $CE2$ HIGH and \overline{WE} LOW. All signals must be in valid states to initiate a Write, but any one can go inactive to terminate the Write. The Data Input Setup and Hold timing are referenced to the rising or falling edge of the signal that terminates the Write.
4. Tested with \overline{OE} HIGH.

AC WAVEFORMS

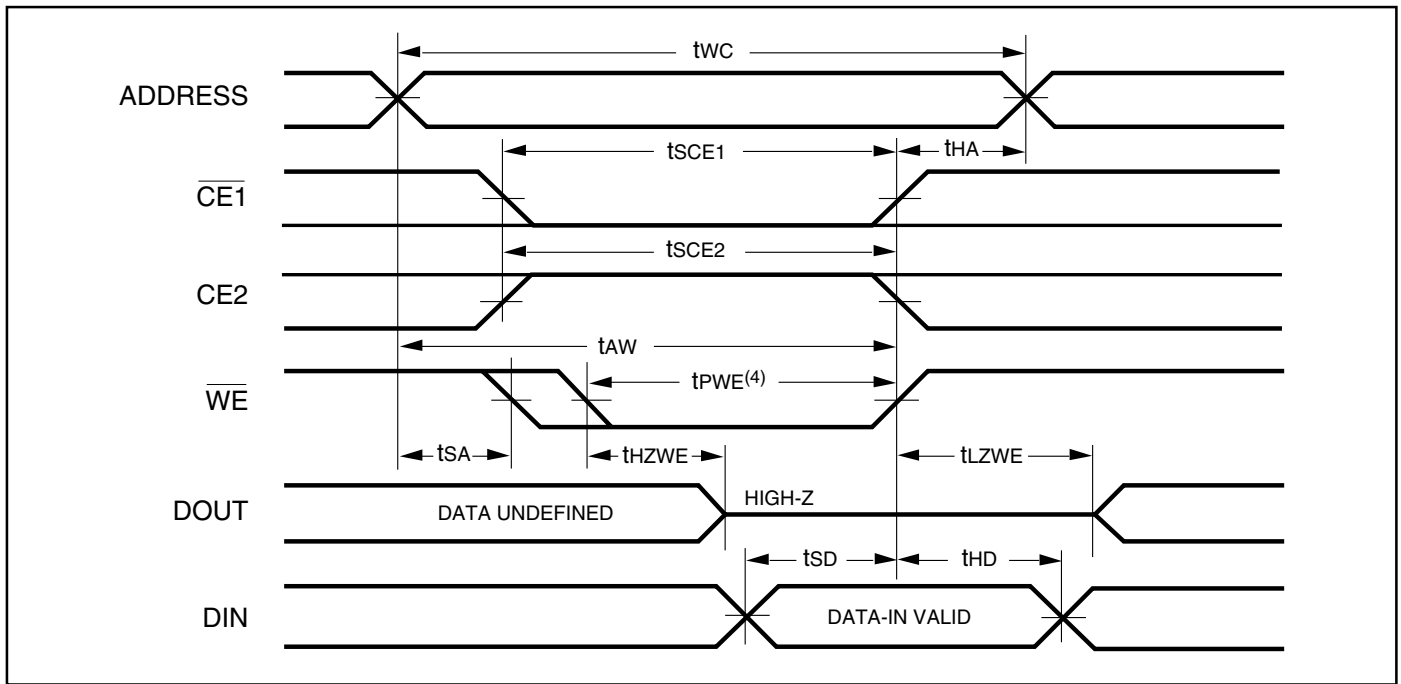
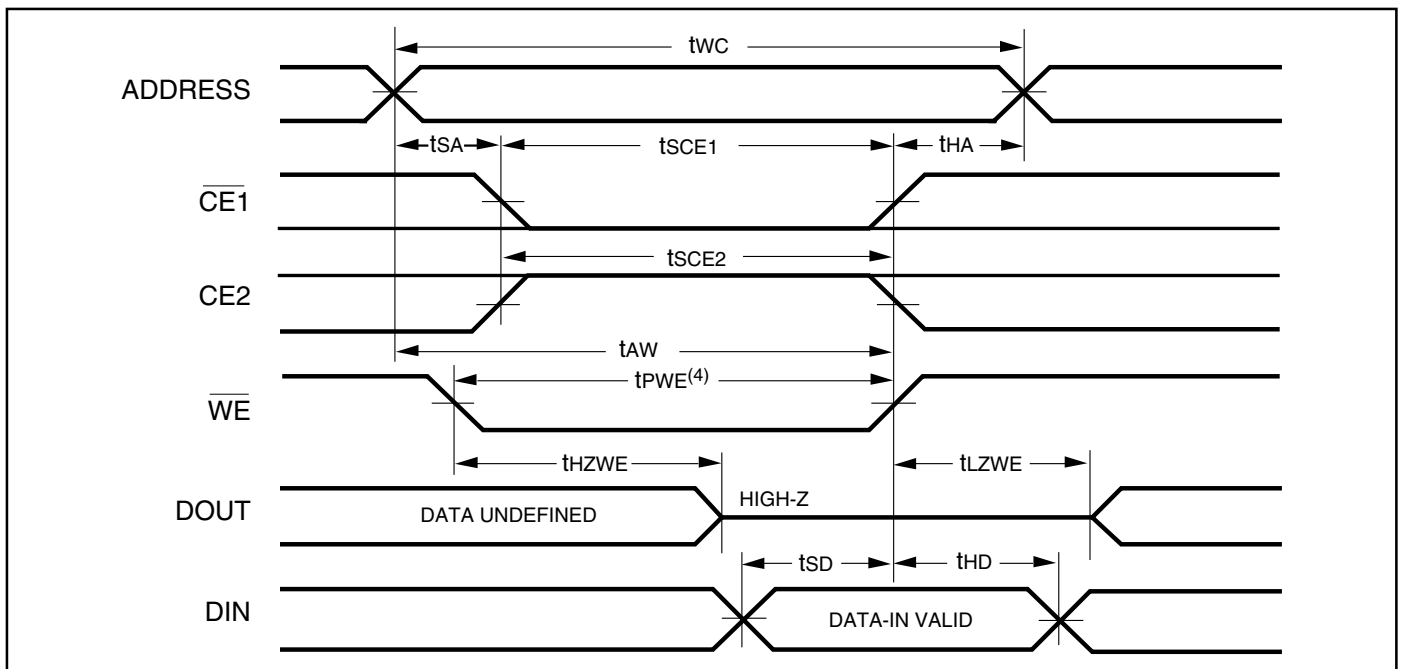
WRITE CYCLE NO. 1 ($\overline{\text{WE}}$ Controlled)^(1,2)WRITE CYCLE NO. 2 ($\overline{\text{CE1}}$, CE2 Controlled)^(1,2)**Notes:**

1. The internal write time is defined by the overlap of $\overline{\text{CE1}}$ LOW, CE2 HIGH and $\overline{\text{WE}}$ LOW. All signals must be in valid states to initiate a Write, but any one can go inactive to terminate the Write. The Data Input Setup and Hold timing are referenced to the rising or falling edge of the signal that terminates the Write.
2. I/O will assume the High-Z state if $\overline{\text{OE}} = V_{IH}$.

ORDERING INFORMATION**Commercial Range: 0°C to +70°C**

Speed (ns)	Order Part No.	Package
35	IS62C1024-35Q	525-mil Plastic SOP
35	IS62C1024-35T	TSOP, Type 1
45	IS62C1024-45Q	525-mil Plastic SOP
45	IS62C1024-45T	TSOP, Type 1
55	IS62C1024-55Q	525-mil Plastic SOP
55	IS62C1024-55T	TSOP, Type 1
70	IS62C1024-70Q	525-mil Plastic SOP
70	IS62C1024-70T	TSOP, Type 1

Industrial Range: -40°C to +85°C

Speed (ns)	Order Part No.	Package
35	IS62C1024-35QI	525-mil Plastic SOP
35	IS62C1024-35TI	TSOP, Type 1
45	IS62C1024-45QI	525-mil Plastic SOP
45	IS62C1024-45TI	TSOP, Type 1
55	IS62C1024-55QI	525-mil Plastic SOP
55	IS62C1024-55TI	TSOP, Type 1
70	IS62C1024-70QI	525-mil Plastic SOP
70	IS62C1024-70TI	TSOP, Type 1

ISSI®

Integrated Silicon Solution, Inc.

2231 Lawson Lane
 Santa Clara, CA 95054
 Tel: 1-800-379-4774
 Fax: (408) 588-0806
 E-mail: sales@issi.com
www.issi.com