

# IS62LV2568ALL



## 256K x 8 LOW POWER and LOW V<sub>CC</sub> CMOS STATIC RAM

AUGUST 2001

### FEATURES

- Access times of 70 and 85 ns
- CMOS low power operation:
  - 120 mW (typical) operating
  - 6  $\mu$ W (typical) standby
- Low data retention voltage: 2V (min.)
- Output Enable ( $\overline{OE}$ ) and two Chip Enable ( $\overline{CE1}$  and CE2) inputs for ease in applications
- TTL compatible inputs and outputs
- Fully static operation:
  - No clock or refresh required
- Single 2.5V (min.) to 3.3V (max.) power supply
- Available in 32-pin TSOP (Type I), STSOP (Type I), and 36-pin mini BGA

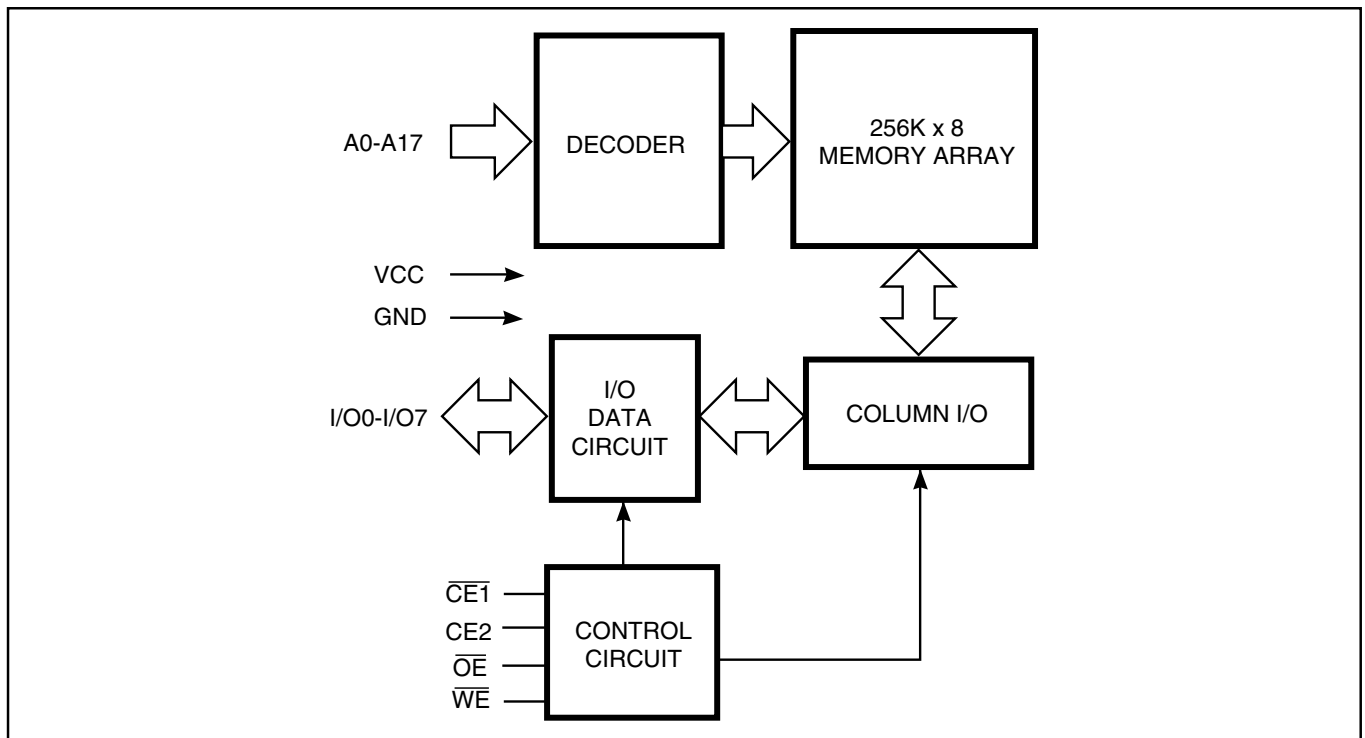
### DESCRIPTION

The *ISSI* IS62LV2568ALL is a low voltage, 262,144 words by 8 bits, CMOS SRAM. It is fabricated using *ISSI*'s low voltage, six transistor (6T), CMOS technology. The device is targeted to satisfy the demands of the state-of-the-art technologies such as cell phones and pagers.

When  $\overline{CE}$  is HIGH (deselected), the device assumes a standby mode at which the power dissipation can be reduced down with CMOS input levels. Additionally, easy memory expansion is provided by using Chip Enable and Output Enable inputs,  $\overline{CE}$  and  $\overline{OE}$ . The active LOW Write Enable ( $\overline{WE}$ ) controls both writing and reading of the memory.

The IS62LV2568ALL is available in 32-pin TSOP (Type I), STSOP (Type I), and 36-pin mini BGA.

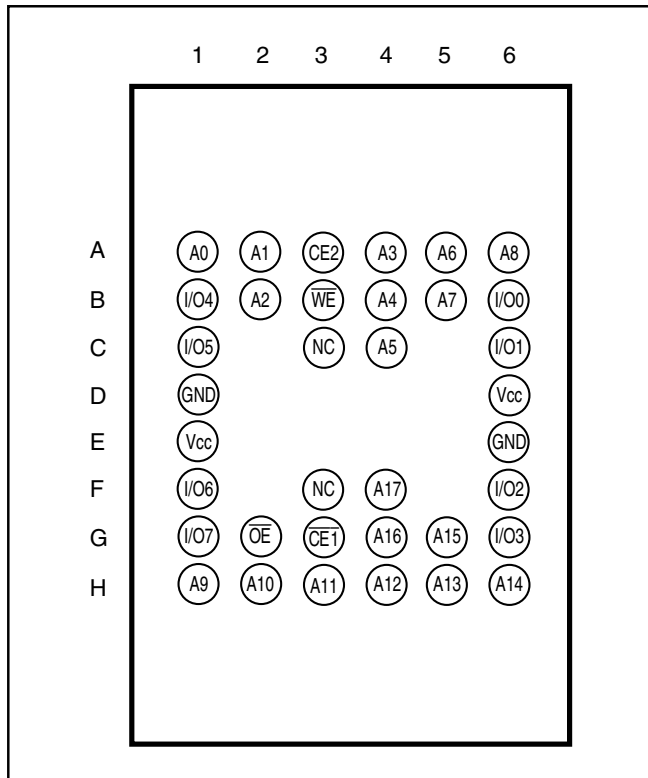
### FUNCTIONAL BLOCK DIAGRAM



ISSI reserves the right to make changes to its products at any time without notice in order to improve design and supply the best possible product. We assume no responsibility for any errors which may appear in this publication. © Copyright 2001, Integrated Silicon Solution, Inc.

**PIN CONFIGURATION**

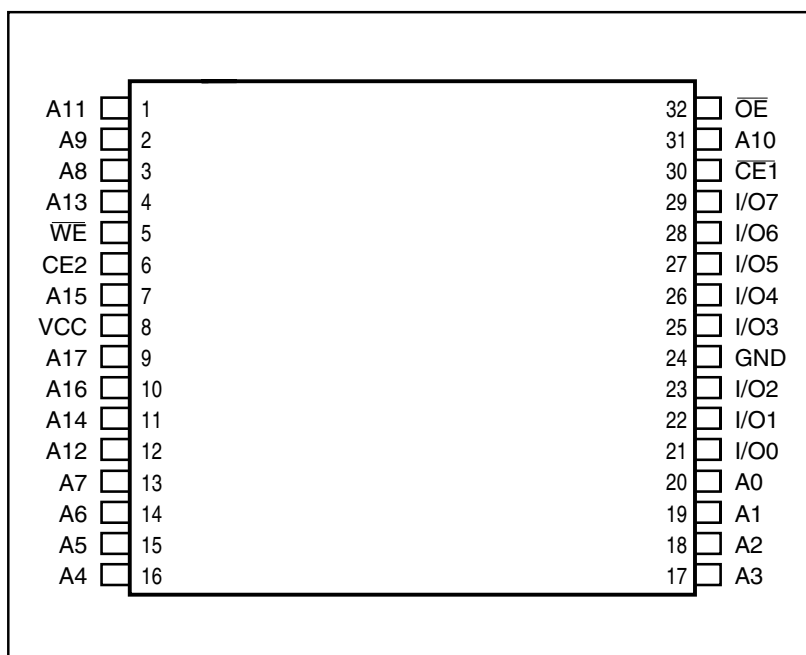
**36-pin mini BGA (B)**



**PIN DESCRIPTIONS**

A0-A17	Address Inputs
$\overline{CE1}$	Chip Enable 1 Input
CE2	Chip Enable 2 Input
$\overline{OE}$	Output Enable Input
$\overline{WE}$	Write Enable Input
I/O0-I/O7	Input/Output
NC	No Connection
Vcc	Power
GND	Ground

**32-Pin TSOP (Type I), STSOP (Type I)**



## TRUTH TABLE

Mode	$\overline{WE}$	$\overline{CE1}$	CE2	$\overline{OE}$	I/O Operation	Vcc Current
Not Selected	X	H	X	X	High-Z	ISB1, ISB2
(Power-down)	X	X	L	X	High-Z	ISB1, ISB2
Output Disabled	H	L	H	H	High-Z	I <sub>CC</sub>
Read	H	L	H	L	D <sub>OUT</sub>	I <sub>CC</sub>
Write	L	L	H	X	D <sub>IN</sub>	I <sub>CC</sub>

## OPERATING RANGE

Range	Ambient Temperature	V <sub>CC</sub> MIN.	V <sub>CC</sub> MAX.
Commercial	0°C to +70°C	2.5V	3.3V
Industrial	-40°C to +85°C	2.5V	3.3V

ABSOLUTE MAXIMUM RATINGS<sup>(1)</sup>

Symbol	Parameter	Value	Unit
V <sub>TERM</sub>	Terminal Voltage with Respect to GND	-0.5 to V <sub>CC</sub> + 0.5	V
V <sub>CC</sub>	V <sub>CC</sub> related to GND	-0.3 to +3.6	V
T <sub>BIAS</sub>	Temperature Under Bias	-40 to +85	°C
T <sub>STG</sub>	Storage Temperature	-65 to +150	°C
P <sub>T</sub>	Power Dissipation	0.7	W

## Note:

1. Stress greater than those listed under ABSOLUTE MAXIMUM RATINGS may cause permanent damage to the device. This is a stress rating only and functional operation of the device at these or any other conditions above those indicated in the operational sections of this specification is not implied. Exposure to absolute maximum rating conditions for extended periods may affect reliability.

CAPACITANCE<sup>(1,2)</sup>

Symbol	Parameter	Conditions	Max.	Unit
C <sub>IN</sub>	Input Capacitance	V <sub>IN</sub> = 0V	6	pF
C <sub>OUT</sub>	Output Capacitance	V <sub>OUT</sub> = 0V	8	pF

## Notes:

1. Tested initially and after any design or process changes that may affect these parameters.
2. Test conditions: T<sub>A</sub> = 25°C, f = 1 MHz, V<sub>CC</sub> = 3.0V.

**DC ELECTRICAL CHARACTERISTICS** (Over Operating Range)

Symbol	Parameter	Test Conditions	Min.	Max.	Unit
V <sub>OH</sub>	Output HIGH Voltage	V <sub>CC</sub> = Min., I <sub>OH</sub> = -1.0 mA	2.0	—	V
V <sub>OL</sub>	Output LOW Voltage	V <sub>CC</sub> = Min., I <sub>OL</sub> = 2.1 mA	—	0.4	V
V <sub>IH</sub>	Input HIGH Voltage		2.2	V <sub>CC</sub> + 0.3	V
V <sub>IL</sub>	Input LOW Voltage <sup>(1)</sup>		-0.3	0.4	V
I <sub>LI</sub>	Input Leakage	GND ≤ V <sub>IN</sub> ≤ V <sub>CC</sub>	-1	1	μA
I <sub>LO</sub>	Output Leakage	GND ≤ V <sub>OUT</sub> ≤ V <sub>CC</sub>	-1	1	μA

**Note:**

1. V<sub>IL</sub> = -3.0V for pulse width less than 10 ns.

**POWER SUPPLY CHARACTERISTICS<sup>(1)</sup>** (Over Operating Range)

Symbol	Parameter	Test Conditions	-70		-85		Unit	
			Min.	Max.	Min.	Max.		
I <sub>CC</sub>	V <sub>CC</sub> Dynamic Operating Supply Current	V <sub>CC</sub> = Max., CE = V <sub>IL</sub>	Com.	—	30	—	25	mA
		I <sub>OUT</sub> = 0 mA, f = f <sub>MAX</sub>	Ind.	—	35	—	30	
I <sub>SB1</sub>	TTL Standby Current (TTL Inputs)	V <sub>CC</sub> = Max.,	Com.	—	0.4	—	0.4	mA
		V <sub>IN</sub> = V <sub>IH</sub> or V <sub>IL</sub> , CE1 ≥ V <sub>IH</sub> or CE2 ≤ V <sub>IL</sub> , f = 0	Ind.	—	1.0	—	1.0	
I <sub>SB2</sub>	CMOS Standby Current (CMOS Inputs)	V <sub>CC</sub> = Max., f = 0	Com.	—	5	—	5	μA
		CE1 ≥ V <sub>CC</sub> - 0.2V, CE2 ≤ 0.2V, or V <sub>IN</sub> ≥ V <sub>CC</sub> - 0.2V, V <sub>IN</sub> ≤ 0.2V	Ind.	—	5	—	5	

**Note:**

1. At f = f<sub>MAX</sub>, address and data inputs are cycling at the maximum frequency, f = 0 means no input lines change.

READ CYCLE SWITCHING CHARACTERISTICS<sup>(1)</sup> (Over Operating Range)

Symbol	Parameter	-70		-85		Unit
		Min.	Max.	Min.	Max.	
t <sub>RC</sub>	Read Cycle Time	70	—	85	—	ns
t <sub>AA</sub>	Address Access Time	—	70	—	85	ns
t <sub>OHA</sub>	Output Hold Time	10	—	15	—	ns
t <sub>ACE1</sub>	$\overline{\text{CE}}1$ Access Time	—	70	—	85	ns
t <sub>ACE2</sub>	CE2 Access Time	—	70	—	85	ns
t <sub>DOE</sub>	$\overline{\text{OE}}$ Access Time	—	35	—	45	ns
t <sub>HZOE</sub> <sup>(2)</sup>	$\overline{\text{OE}}$ to High-Z Output	—	25	—	25	ns
t <sub>LZOE</sub> <sup>(2)</sup>	$\overline{\text{OE}}$ to Low-Z Output	5	—	5	—	ns
t <sub>LZCE1</sub> <sup>(2)</sup>	$\overline{\text{CE}}1$ to Low-Z Output	10	—	10	—	ns
t <sub>LZCE2</sub> <sup>(2)</sup>	CE2 to Low-Z Output	10	—	10	—	ns
t <sub>HZCE</sub> <sup>(2)</sup>	$\overline{\text{CE}}1$ or CE2 to High-Z Output	0	25	0	25	ns

**Notes:**

- Test conditions assume signal transition times of 5 ns or less, timing reference levels of 1.3V, input pulse levels of 0.4V to 2.2V and output loading specified in Figure 1.
- Tested with the load in Figure 2. Transition is measured  $\pm 500$  mV from steady-state voltage. Not 100% tested.

**AC TEST CONDITIONS**

Parameter	Unit
Input Pulse Level	0.4V to 2.2V
Input Rise and Fall Times	5 ns
Input and Output Timing and Reference Level	1.3V
Output Load	See Figures 1 and 2

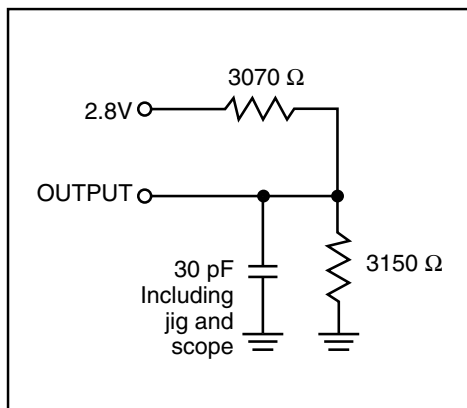
**AC TEST LOADS**

Figure 1

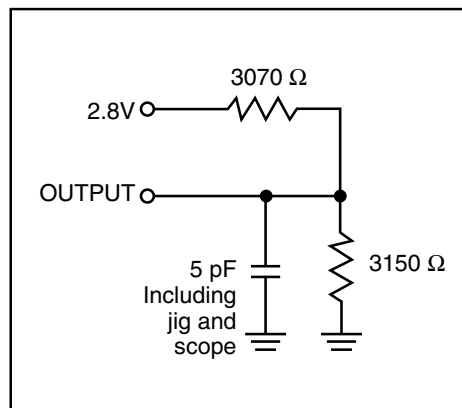
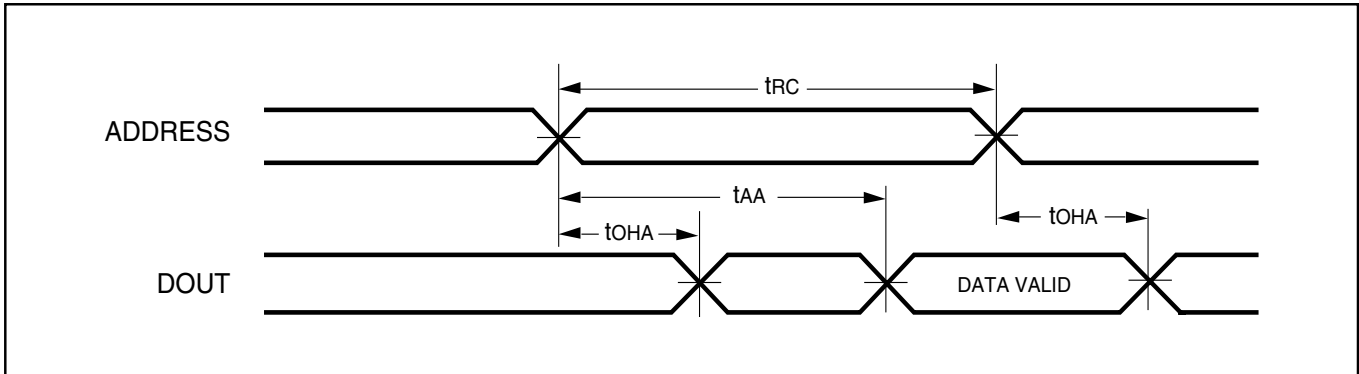


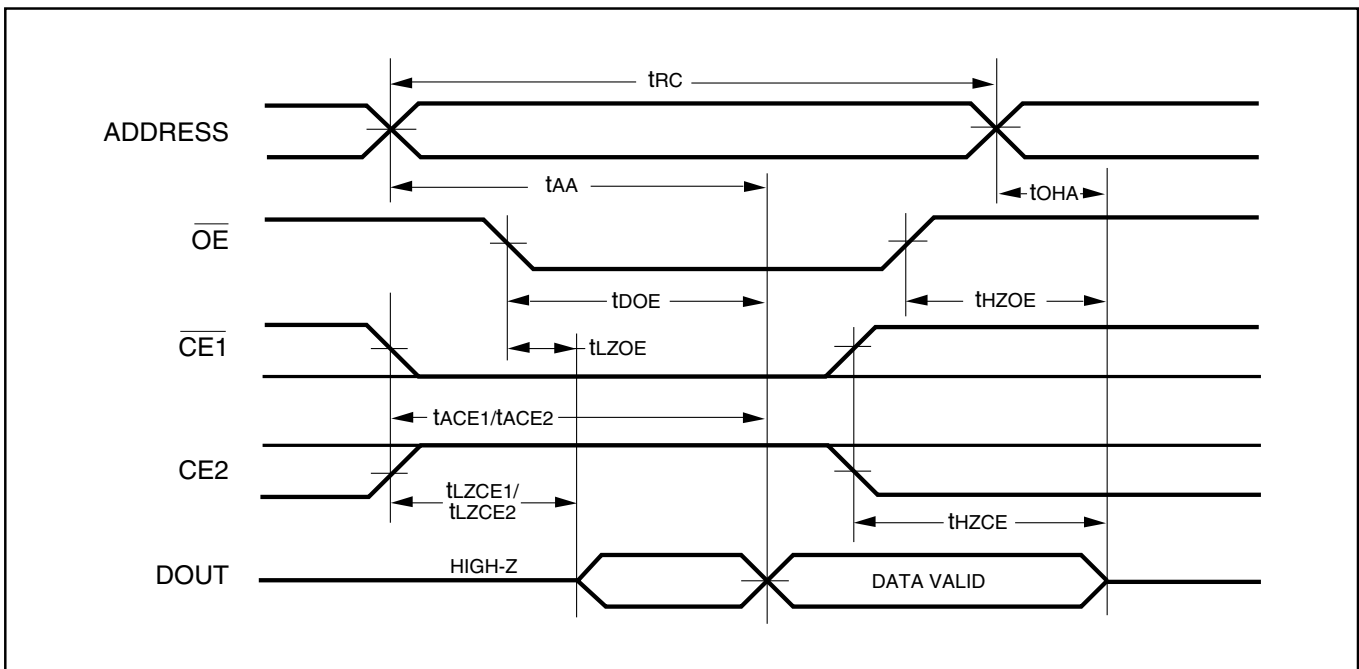
Figure 2

AC WAVEFORMS

READ CYCLE NO. 1<sup>(1,2)</sup>



READ CYCLE NO. 2<sup>(1,3)</sup>



Notes:

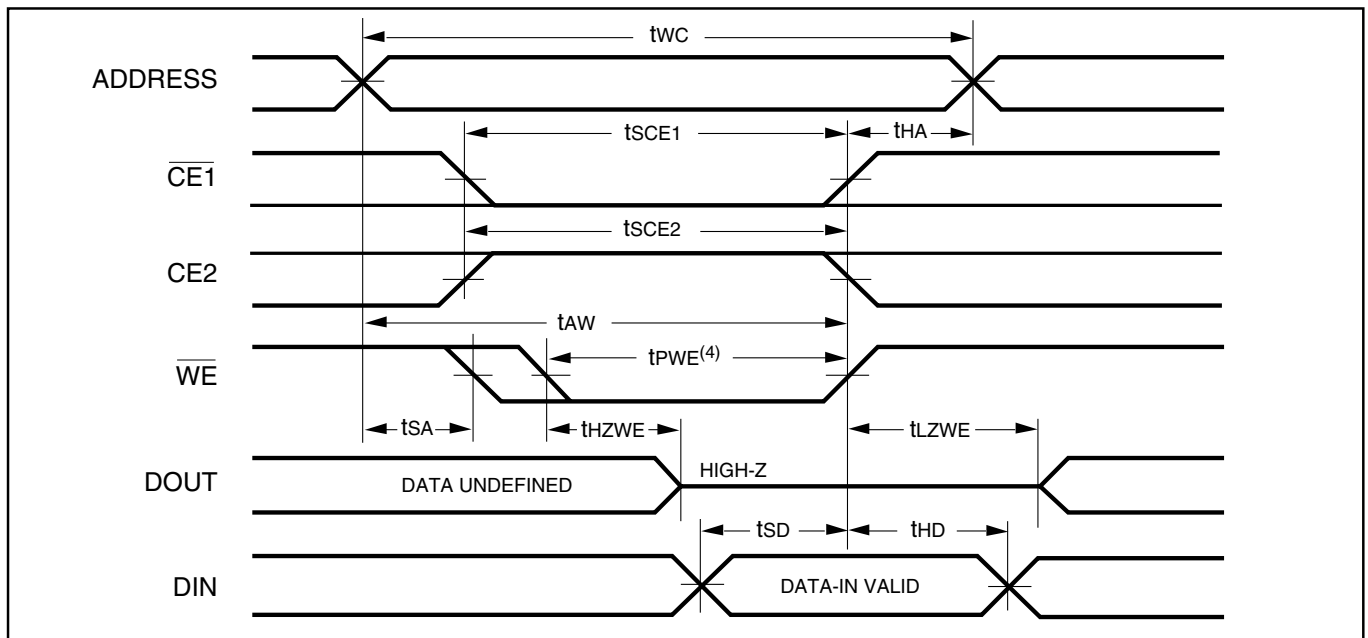
1.  $\overline{WE}$  is HIGH for a Read Cycle.
2. The device is continuously selected.  $\overline{OE}$ ,  $\overline{CE1} = V_{IL}$ ,  $CE2 = V_{IH}$ .
3. Address is valid prior to or coincident with  $\overline{CE1}$  LOW and CE2 HIGH transitions.

**WRITE CYCLE SWITCHING CHARACTERISTICS<sup>(1,3)</sup>** (Over Operating Range, Standard and Low Power)

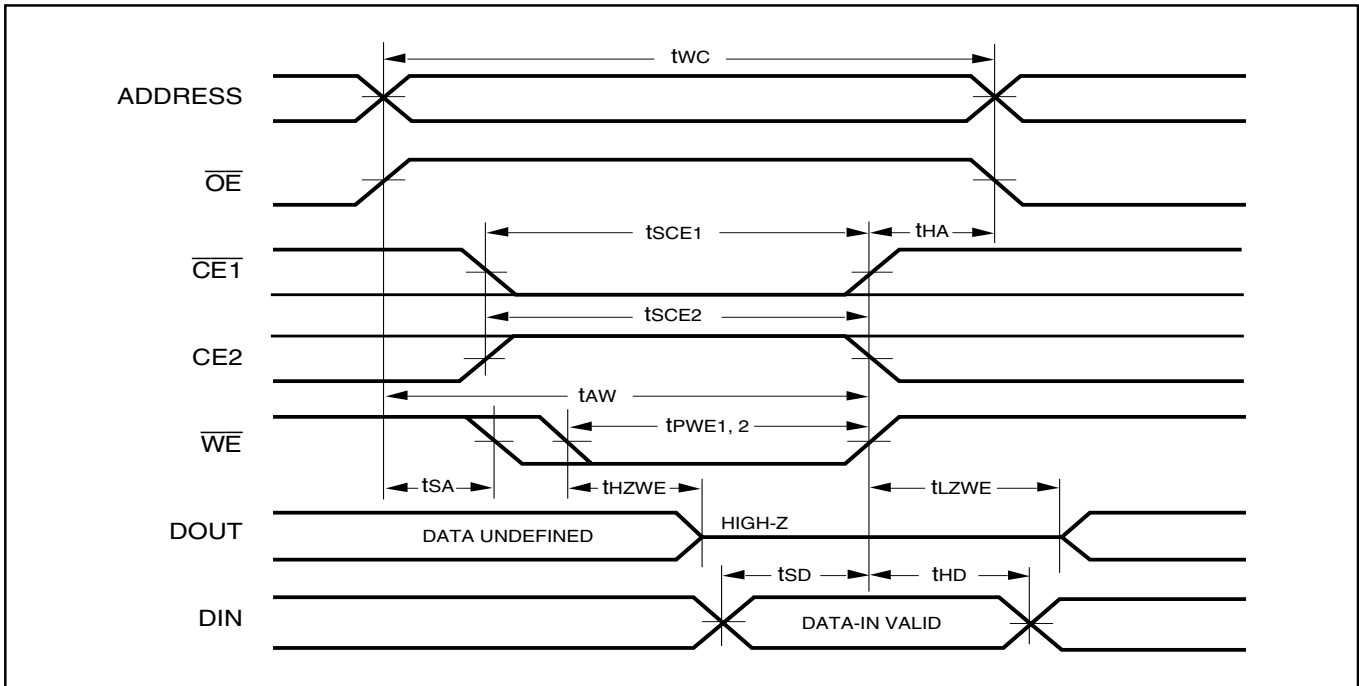
Symbol	Parameter	-70		-85		Unit
		Min.	Max.	Min.	Max.	
t <sub>WC</sub>	Write Cycle Time	70	—	85	—	ns
t <sub>SCE1</sub>	$\overline{CE1}$ to Write End	65	—	70	—	ns
t <sub>SCE2</sub>	CE2 to Write End	65	—	70	—	ns
t <sub>AW</sub>	Address Setup Time to Write End	65	—	70	—	ns
t <sub>HA</sub>	Address Hold from Write End	0	—	0	—	ns
t <sub>SA</sub>	Address Setup Time	0	—	0	—	ns
t <sub>PWE<sup>(4)</sup></sub>	$\overline{WE}$ Pulse Width	60	—	60	—	ns
t <sub>SD</sub>	Data Setup to Write End	30	—	35	—	ns
t <sub>HD</sub>	Data Hold from Write End	0	—	0	—	ns
t <sub>HZWE<sup>(2)</sup></sub>	$\overline{WE}$ LOW to High-Z Output	—	33	—	25	ns
t <sub>LZWE<sup>(2)</sup></sub>	$\overline{WE}$ HIGH to Low-Z Output	5	—	5	—	ns

**Notes:**

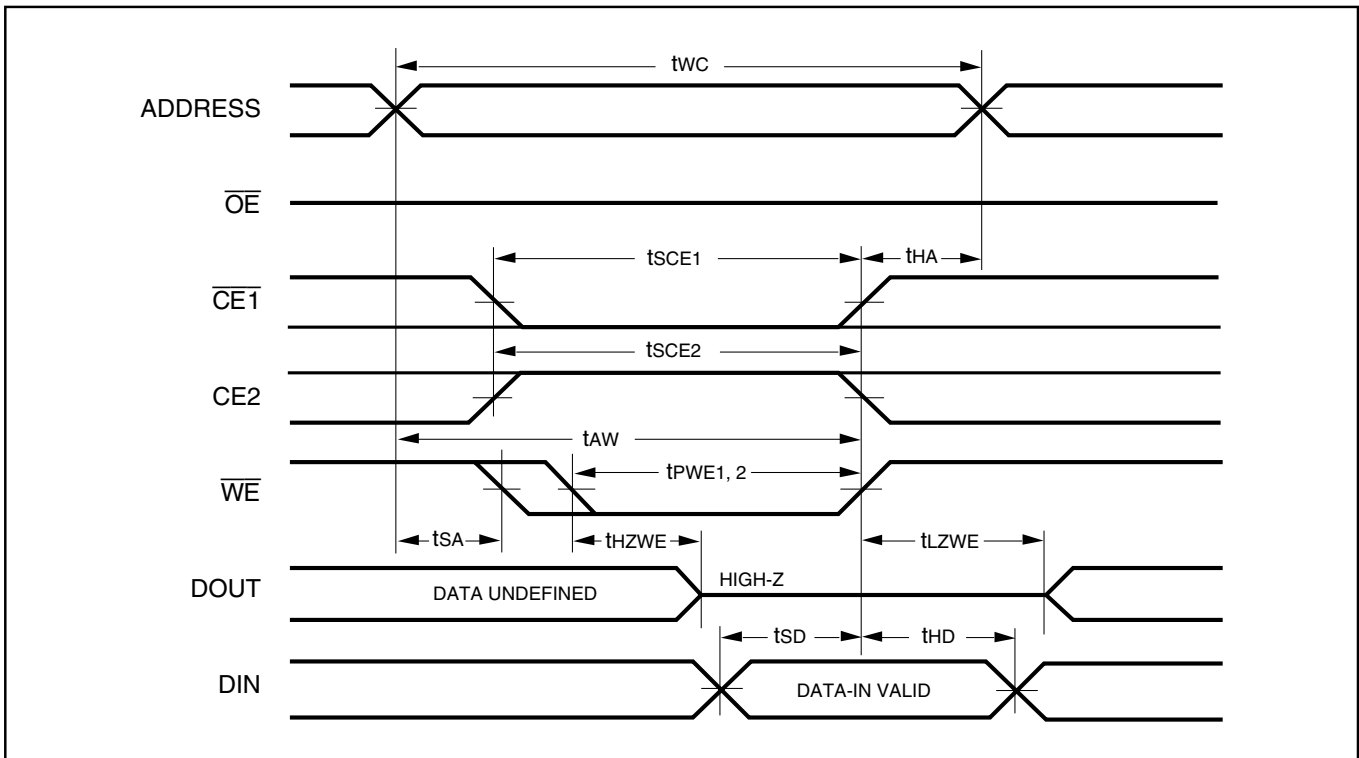
1. Test conditions assume signal transition times of 5ns or less, timing reference levels of 1.3V, input pulse levels of 0.4V to 2.2V and output loading specified in Figure 1.
2. Tested with the load in Figure 2. Transition is measured  $\pm 500$  mV from steady-state voltage. Not 100% tested.
3. The internal write time is defined by the overlap of  $\overline{CE1}$  LOW, CE2 HIGH and  $\overline{WE}$  LOW. All signals must be in valid states to initiate a Write, but any one can go inactive to terminate the Write. The Data Input Setup and Hold timing are referenced to the rising or falling edge of the signal that terminates the Write.
4. Tested with OE HIGH.

**AC WAVEFORMS****WRITE CYCLE NO. 1** ( $\overline{CE}$  Controlled,  $\overline{OE}$  = HIGH or LOW)

**WRITE CYCLE NO. 2** ( $\overline{WE}$  Controlled:  $\overline{OE}$  is HIGH During Write Cycle)



**WRITE CYCLE NO. 3** ( $\overline{WE}$  Controlled:  $\overline{OE}$  is LOW During Write Cycle)

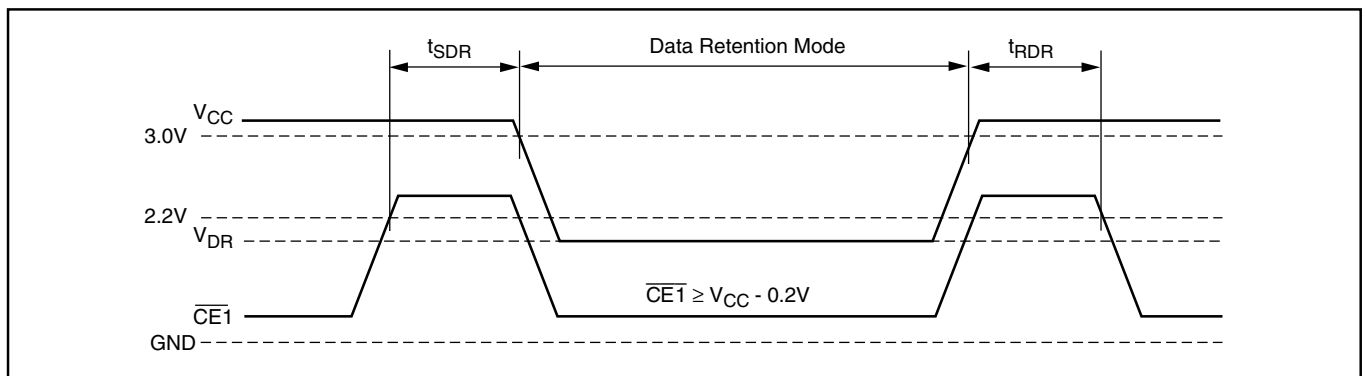




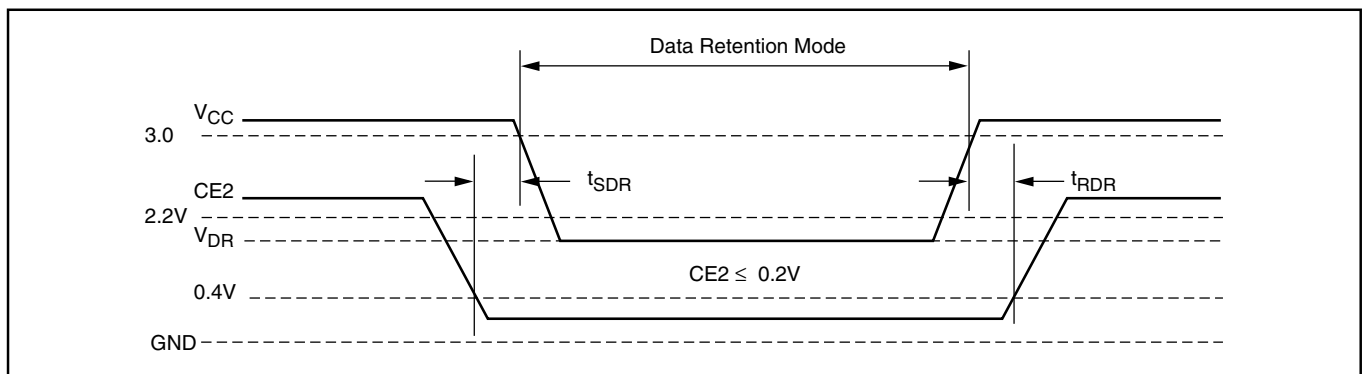
**DATA RETENTION SWITCHING CHARACTERISTICS**

Symbol	Parameter	Test Condition	Min.	Max.	Unit
V <sub>DR</sub>	V <sub>CC</sub> for Data Retention	See Data Retention Waveform	2.0	3.3	V
I <sub>DR</sub>	Data Retention Current	V <sub>CC</sub> = 2.0V, $\overline{CE1} \geq V_{CC} - 0.2V$	Com. Ind.	— 2 5	$\mu A$ $\mu A$
t <sub>SDR</sub>	Data Retention Setup Time	See Data Retention Waveform	0	—	ns
t <sub>RDR</sub>	Recovery Time	See Data Retention Waveform	t <sub>RC</sub>	—	ns

**DATA RETENTION WAVEFORM ( $\overline{CE1}$  Controlled)**



**DATA RETENTION WAVEFORM (CE2 Controlled)**



**ORDERING INFORMATION****Commercial Range: 0°C to +70°C**

<b>Speed (ns)</b>	<b>Order Part No.</b>	<b>Package</b>
70	IS62LV2568ALL-70B	mini BGA (6mm x 8mm)
	IS62LV2568ALL-70T	TSOP, Type I
	IS62LV2568ALL-70H	STSOP, Type I
85	IS62LV2568ALL-85B	mini BGA (6mm x 8mm)
	IS62LV2568ALL-85T	TSOP, Type I
	IS62LV2568ALL-85H	STSOP, Type I

**Industrial Range: -40°C to +85°C**

<b>Speed (ns)</b>	<b>Order Part No.</b>	<b>Package</b>
70	IS62LV2568ALL-70BI	mini BGA (6mm x 8mm)
	IS62LV2568ALL-70TI	TSOP, Type I
	IS62LV2568ALL-70HI	STSOP, Type I
85	IS62LV2568ALL-85BI	mini BGA (6mm x 8mm)
	IS62LV2568ALL-85TI	TSOP, Type I
	IS62LV2568ALL-85HI	STSOP, Type I

**ISSI<sup>®</sup>****Integrated Silicon Solution, Inc.**

2231 Lawson Lane  
Santa Clara, CA 95054  
Tel: 1-800-379-4774  
Fax: (408) 588-0806  
E-mail: sales@issi.com  
**www.issi.com**