

Single Phase Rectifier Bridge

$I_{dAVM} = 107 \text{ A}$
 $V_{RRM} = 1200-1800 \text{ V}$

V_{RSM}	V_{RRM}	Type
V	V	
900	800	VBO 105-08NO7
1200	1200	VBO 105-12NO7
1400	1400	VBO 105-14NO7
1600	1600	VBO 105-16NO7
1800	1800	VBO 105-18NO7*

* delivery time on request

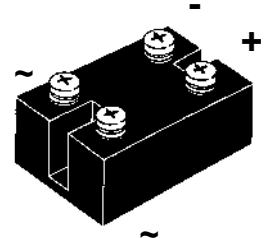
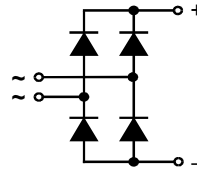

Symbol	Test Conditions	Maximum Ratings
I_{dAVM}	$T_C = 85^\circ\text{C}$, module	107 A
I_{FSM}	$T_{VJ} = 45^\circ\text{C}$; $V_R = 0$	t = 10 ms (50 Hz), sine 1500 A
		t = 8.3 ms (60 Hz), sine 1650 A
I^2t	$T_{VJ} = T_{VJM}$; $V_R = 0$	t = 10 ms (50 Hz), sine 1350 A
		t = 8.3 ms (60 Hz), sine 1500 A
T_{VJ}	$T_{VJ} = T_{VJM}$; $V_R = 0$	t = 10 ms (50 Hz), sine 11250 A ² s
		t = 8.3 ms (60 Hz), sine 11300 A ² s
T_{VJM}		-40...+150 °C
T_{stg}		150 °C
V_{ISOL}	50/60 Hz, RMS $I_{ISOL} \leq 1 \text{ mA}$	t = 1 min 2500 V~
		t = 1 s 3000 V~
M_d	Mounting torque (M5)	5 ± 15 % Nm
		44 ± 15 % lb.in.
Weight	typ.	Terminal connection torque (M5)
		5 ± 15 % Nm
		44 ± 15 % lb.in.

Features

- Package with screw terminals
- Isolation voltage 3000 V~
- Planar passivated chips
- Blocking voltage up to 1800 V
- Low forward voltage drop
- UL registered E 72873

Applications

- Supplies for DC power equipment
- Input rectifiers for PWM inverter
- Battery DC power supplies
- Field supply for DC motors

Advantages

- Easy to mount with two screws
- Space and weight savings
- Improved temperature and power cycling

Dimensions in mm (1 mm = 0.0394")

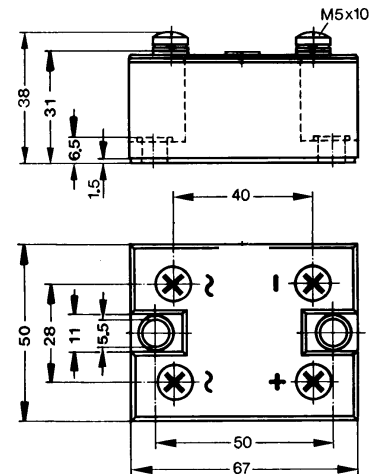

Symbol	Test Conditions	Characteristic Values
I_R	$V_R = V_{RRM}^*$; $T_{VJ} = 25^\circ\text{C}$	$\leq 0.3 \text{ mA}$
	$V_R = V_{RRM}^*$; $T_{VJ} = T_{VJM}$	$\leq 8.0 \text{ mA}$
V_F	$I_F = 150 \text{ A}$; $T_{VJ} = 25^\circ\text{C}$	$\leq 1.6 \text{ V}$
V_{T0}	For power-loss calculations only	0.8 V
r_T	$T_{VJ} = T_{VJM}$	5 mΩ
R_{thJC}	per diode; 180°	0.83 K/W
	per module; 180°	0.138 K/W
R_{thJK}	per diode ; 180°	1.13 K/W
	per module; 180°	0.188 K/W

Data according to IEC 60747 refer to a single diode unless otherwise stated. IXYS reserves the right to change limits, test conditions and dimensions.