

DUAL HEADPHONE DRIVER (1.5V USE)

KIA6206F is a dual Headphone Driver IC designed for low voltage operation. (1.5V, 3.0V) Which is suitable for stereo headphone radio and radio cassette recorder equipments. This item can realize the low power dissipation and have high power output capability.

FEATURES

- Condenser-less for input and output.
 - Condenser-less for bootstrap.
 - Built-in the muting function.
 - High power output capability according to adopting the matrix drive method.
- $P_{OUT(1)}=14\text{mW/ch(Typ.)}$ at $V_{IN(R)}=V_{IN(L)}$ Mode
 $P_{OUT(2)}=5.5\text{mW/ch(Typ.)}$ at $V_{IN(R)}=-V_{IN(L)}$ Mode
 $P_{OUT(3)}=10.5\text{mW/ch(Typ.)}$ at $V_{IN(R)}=0$ or $V_{IN(L)}=0$
 ($V_{CC}=1.5\text{V}$, $R_L=32\Omega$, $f=1\text{kHz}$, $\text{THD}=10\%$)
- Operating supply voltage range.
 $: V_{CC(\text{opr})}=0.9\sim 5.0\text{V}(T_a=25^\circ\text{C})$

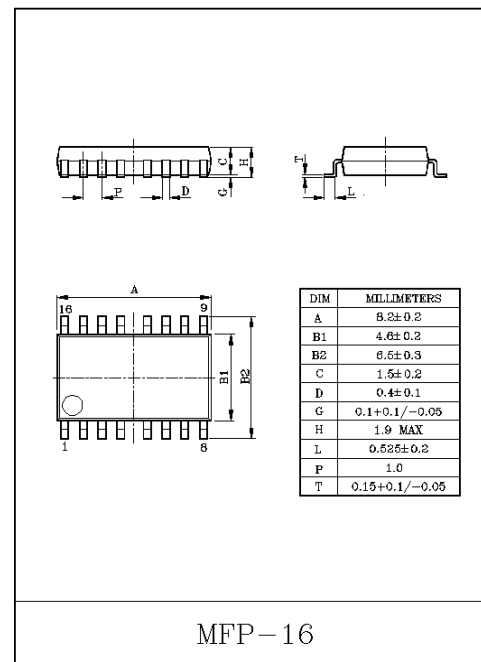

MAXIMUM RATINGS (Ta=25°C)

CHARACTERISTIC	SYMBOL	RATING	UNIT
Supply Voltage	V_{CC}	5	V
Output Current	$I_{O(\text{peak})}$	160	mA
Power Dissipation (Note)	P_D	350	mW
Operating Temperature	T_{opr}	-25~75	°C
Storage Temperature	T_{stg}	-55~150	°C

Note : Derated above $T_a=25^\circ\text{C}$ in the proportion of $2.8\text{mW}/^\circ\text{C}$ for KIA6206F.

KIA6206F

BLOCK DIAGRAM

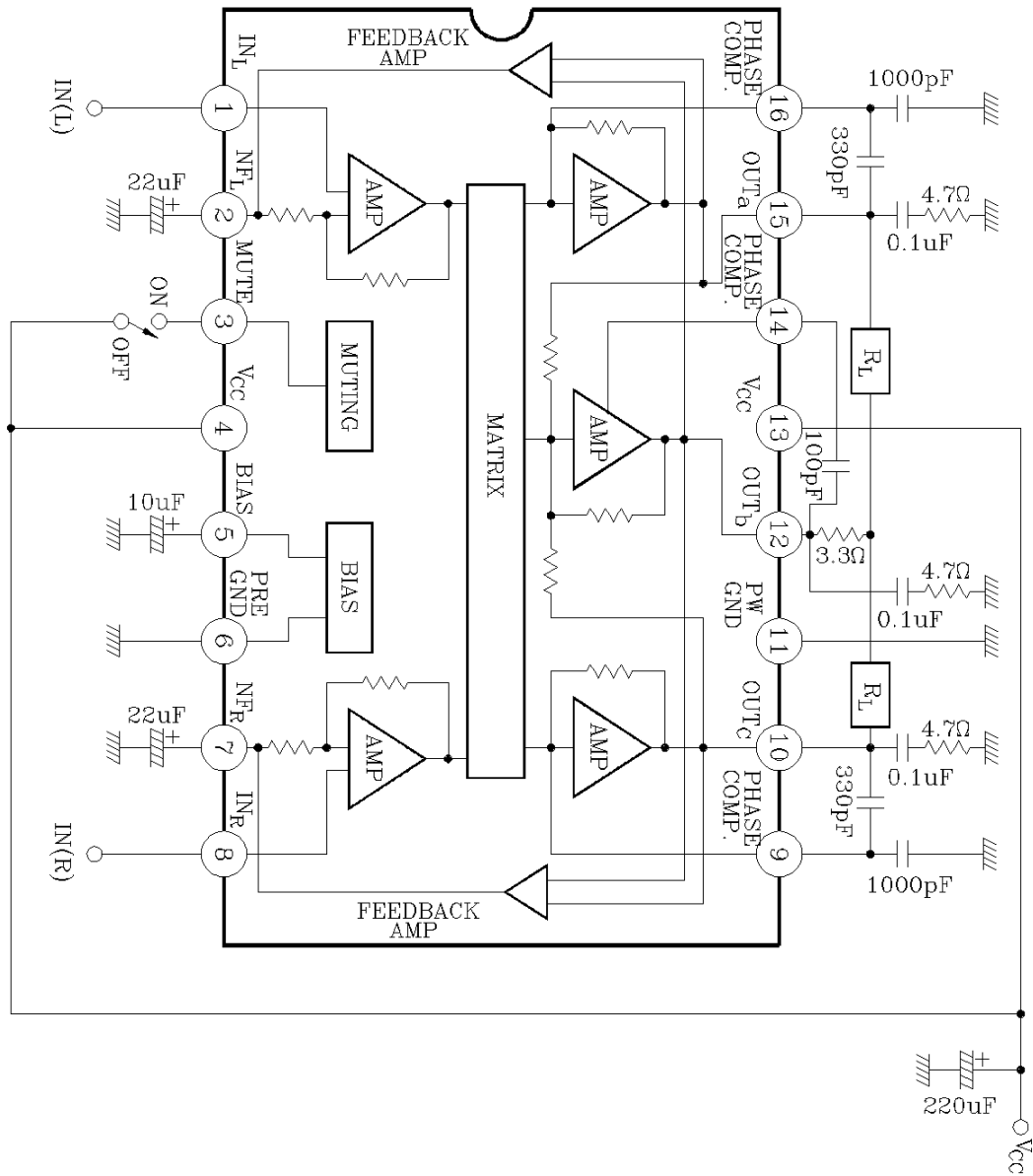

KIA6206F

ELECTRICAL CHARACTERISTICS (AC)

(Unless otherwise specified, $T_a=25^{\circ}\text{C}$, $V_{CC}=1.5\text{V}$, $f=1\text{kHz}$, $R_g=620\Omega$, $R_L=32\Omega$)

CHARACTERISTIC	SYMBOL	TEST CIRCUIT	TEST CONDITION	MIN.	TYP.	MAX.	UNIT
Quiescent Supply Current	I_{CCQ}	-	$V_{IN}=0$	-	6	8.4	mA
Input resistance	R_{IN}	-		-	50	-	k Ω
Voltage Gain	G_v	-	$V_{IN}=-50\text{dBV}$ $V_{IN(R)}=V_{IN(L)}$	30	33	36	dB
Channel Balance	C·B	-		-	0	1.3	dB
Output Power	$P_o(1)$	-	$V_{IN(R)}=V_{IN(L)}$ THD=10%	11	14	-	mW
	$P_o(2)$	-	$V_{IN(R)}=-V_{IN(L)}$ THD=10%	-	5.5	-	
	$P_o(3)$	-	$V_{IN(R)}=0$ or $V_{IN(L)}=0$ THD=10%	-	10.5	-	
Total Harmonic Distortion	THD(1)	-	$P_{O(L)}=P_{O(R)}=1\text{mW}$ $V_{IN(R)}=V_{IN(L)}$	-	0.4	1.0	%
	THD(2)	-	$P_{O(L)}=P_{O(R)}=1\text{mW}$ $V_{IN(R)}=-V_{IN(L)}$	-	2.5	-	
	THD(3)	-	$V_{IN(R)}=0$ or $V_{IN(L)}=0$ $P_O=1\text{mW}$	-	0.9	-	
Output Noise Voltage	V_{NO}	-	B.W.=20Hz~20kHz $R_g=600\Omega$	-	0.15	0.3	mV _{rms}
Cross Talk	C.T.	-	$V_O=-10\text{dBV}$, $R_g=600\Omega$	-	32	-	dB
Ripple Rejection Ratio	R.R.	-	$V_{RIP}=-30\text{dBV}$, $f_{RIP}=100\text{Hz}$	-	35	-	dB
Muting Attenuation	ATT	-	$V_{MUTE}=1.5\text{V}$	-	60	-	dB

KIA6206F

DC CHARACTERISTICS ($V_{CC}=1.5V$, $T_a=25^{\circ}C$, Terminal voltage at no signal)

PIN NO.	SYMBOL	TYP.	UNIT
PIN 1 (INPUT L)	V1	0.16	V
PIN 2 (NF L)	V2	0.73	V
PIN 3 (MUTE)	V3	-	V
PIN 4 (V_{CC})	V4	1.50	V
PIN 5 (BIAS)	V5	0.74	V
PIN 6 (PRE GND)	V6	0	V
PIN 7 (NF R)	V7	0.73	V
PIN 8 (INPUT R)	V8	0.16	V
PIN 9 (PHASE COMPENSATION)	V9	0.80	V
PIN 10 (OUTPUT)	V10	0.75	V
PIN 11 (PW. GND)	V11	0	V
PIN 12 (OUTPUT)	V12	0.75	V
PIN 13 (V_{CC})	V13	1.50	V
PIN 14 (PHASE COMPENSATION)	V14	0.80	V
PIN 15 (OUTPUT)	V15	0.75	V
PIN 16 (PHASE COMPENSATION)	V16	0.80	V

TEST CIRCUIT

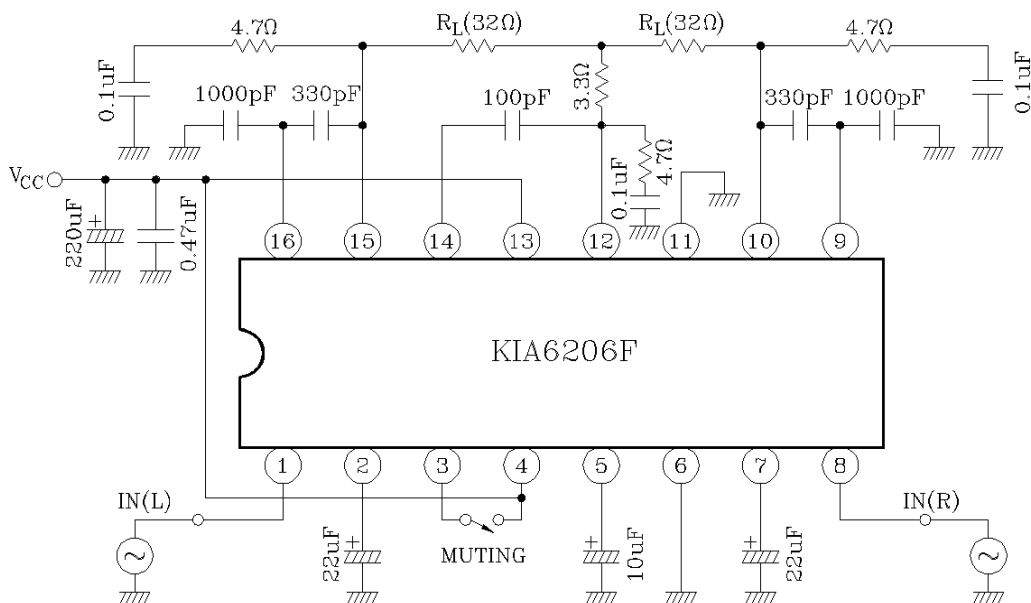

SUMMARY OF MATRIX DRIVE METHOD

Though the BTL is usually used to obtain enough power at low voltage, it can not be used for the headphone driver (especially, 1.5V USE), which has only one left-and right common line.

Then a new modified BTL drive method is developed, which is called "Matrix Drive Method". It has only one common line.

Fig.1 Shows the Principle. The input signals of the audio frequency are applied to the terminal of L/R. These are transformed by the matrix converter into the outputs, as following :

$$V\textcircled{a} = L - \alpha R$$

$$V\textcircled{b} = -\alpha (L+R)$$

$$V\textcircled{c} = R - \alpha L$$

: matrix ratio L,R : input signal

And the output signals of L/R loads are given by

$$V_L = V\textcircled{a} - V\textcircled{b} = (1 + \alpha)L$$

$$V_R = V\textcircled{c} - V\textcircled{a} = (1 + \alpha)R$$

Thus, each output signal does not leak to another channel load.

This gain is $(1 + \alpha)$ times as high as a conventional single amplifiers.

However the undistorted maximum output is determined by each clipping point of lines, \textcircled{a} , \textcircled{b} , and \textcircled{c} .

Therefore, the most effective point is determined by the following states of input. As the state of input is at L=R mode, α is 1/3, so this system is operated most effectively.

At L=-R mode, α is whatever. And at single input mode (L or R only), α is 1. It is a common saying that the practical musical source consists of the common phase component in most. And the low frequency of that causes the clipping to product mostly. Therefore in this item, α is 1/3.

In result at L=R mode, this gain is obtained twice as high as a single amplifiers.

At single input mode, 4/3 times, at L=-R mode, is obtained as same as a single.

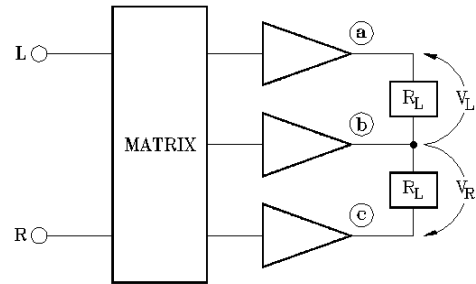

Fig. 1

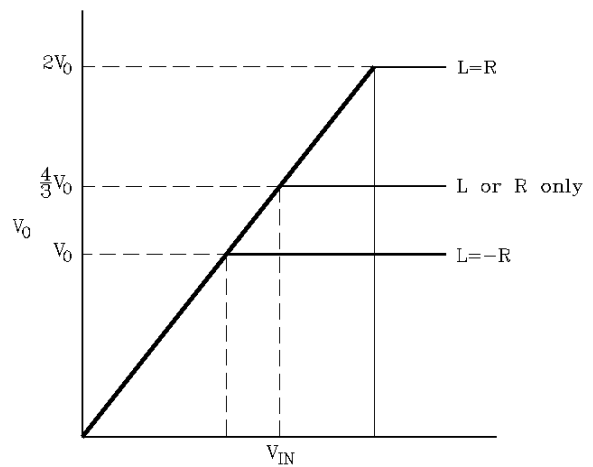

Fig. 2

APPLICATION INFORMATION

(1) Input Stage

The first stage is composed of the differential amplifier of PNP-input. Therefore, it is not necessary to use any coupling condensers (Fig.3). The input impedance is determined by the internal resistance(51kΩ). This output is connected to the next stage through the emitter follower.

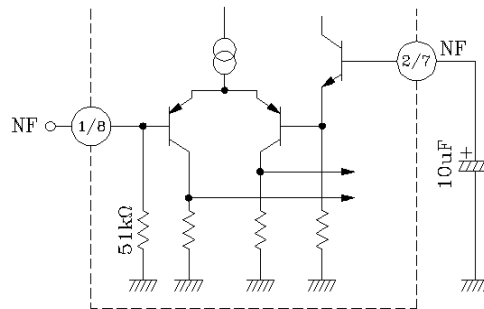

Fig. 3

(2) Matrix Converter

The matrix ratio is determined by the amplifier A1, A2 as shown in Fig.4. Each of the output currents, which have a ratio (1 : α), is formed by A1, A2. The outputs of matrix converter, which are previously mentioned, are

- Ⓐ : $L - \alpha R$
- Ⓑ : $-\alpha (L + R)$
- Ⓒ : $R - \alpha L$

These is applied to the drivers B1, C, B2.

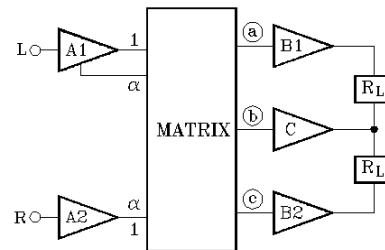

Fig. 4

(3) Muting Function

As the terminal pin ③ for the muting function is connected to Vcc, Q1 is turned on, then Q2 and Q3 are turned on. Therefore the DC voltage of the terminal pin ⑤ is down, and all of the circuits stop. At this time, the quiescent supply current(I_{CCQ}) scarcely flows into this system. As the terminal pin ③ is opened, the DC voltage of the terminal pin ⑤ does not quickly come up, because of the presence of the CR time-constant. So, the shock-noise is reduced. As the supply voltage is turned on, this operation is also done.

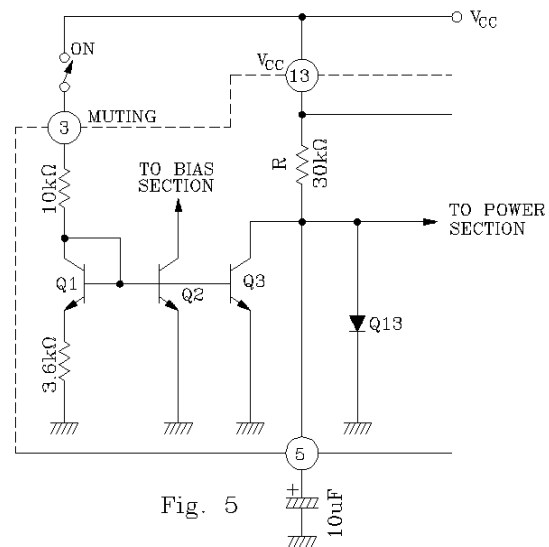

Fig. 5

KIA6206F

(4) DC Feed-Back Circuit

In this system, the output loads are directly connected to the output terminals. Therefore, in order that the output DC offset voltages are reduced, this system is built-in the DC feed-back circuit. The currents, which are in proportion of the differential voltage between two DC terminal voltage in each.

$$i_1 = K (V_{\text{a}} - V_{\text{b}})$$

$$i_2 = K (V_{\text{c}} - V_{\text{b}})$$

are fed into the matrix converter. Thus the DC offset voltages are reduced. This system is effective more than about 1.2V

(5) Total Gain : G_V

In this system, the total gain G_V is given by

$$G_V = 20 \log \frac{4R_2}{R_1}$$

Typical values of this system is $R_1=1.6k\Omega$, $R_2=19k\Omega$, then this gain is:

$$G_V = 34\text{dB(Typ.)}$$

Note: The internal resistances are fixed, then the gain is fixed. In additional to the attenuator in front of this system, the gain is changeable.

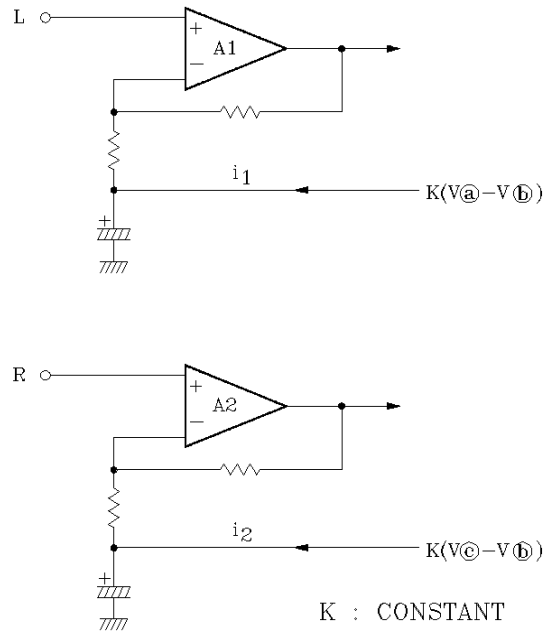

Fig. 6

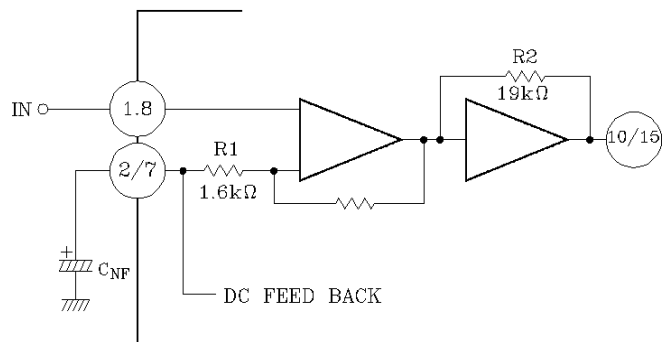
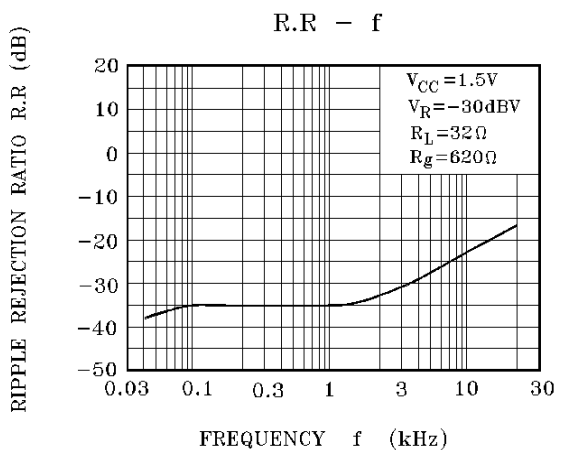
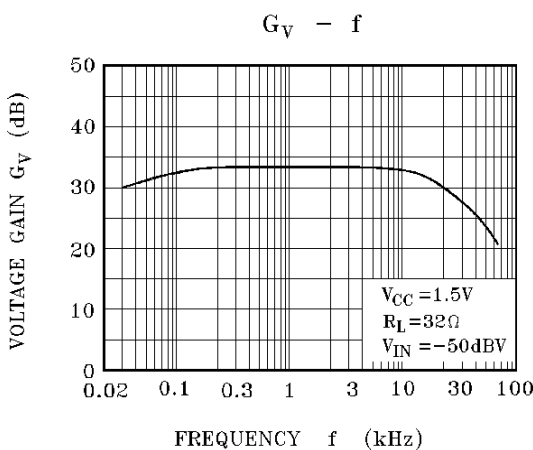
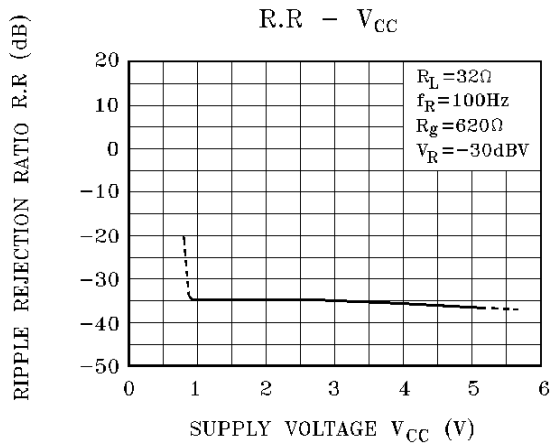
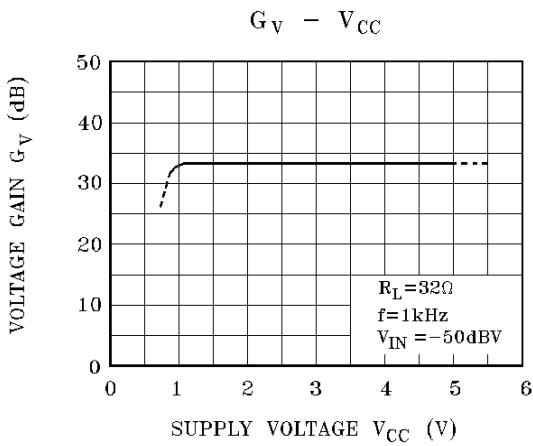
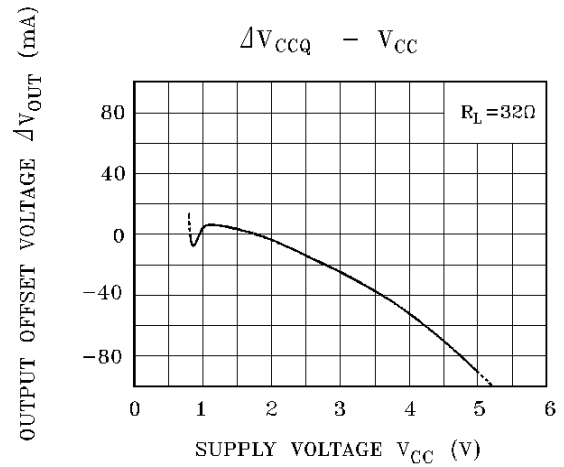
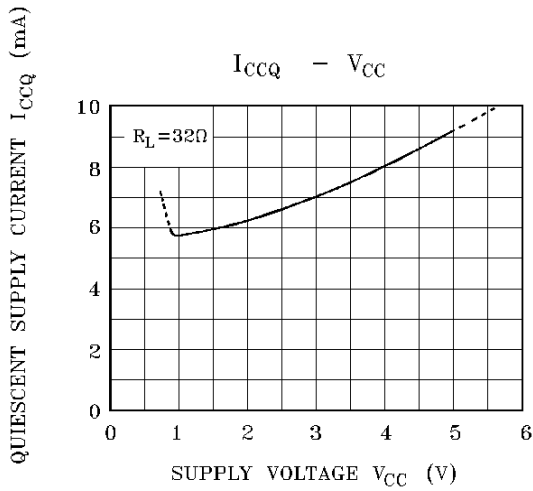

FIG. 7

KIA6206F



KIA6206F

C.T. - f

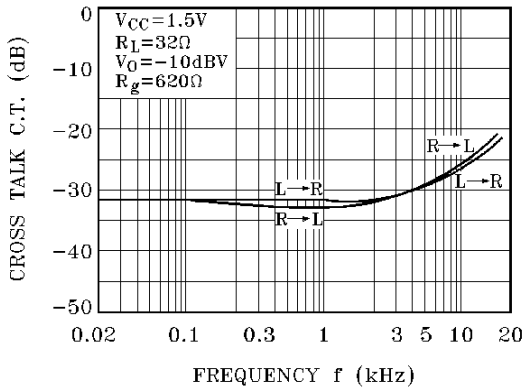

C.T. - P_0

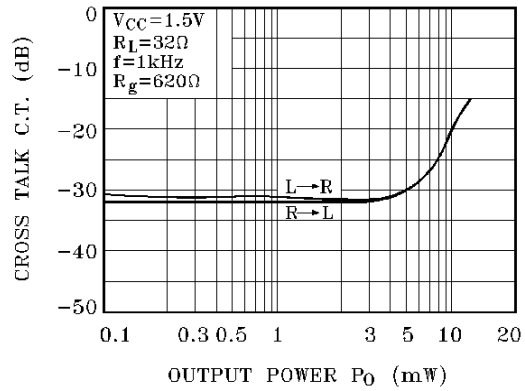

THD - P_0

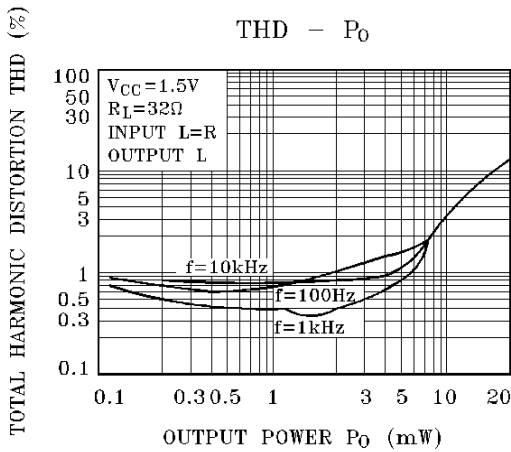

THD - P_0

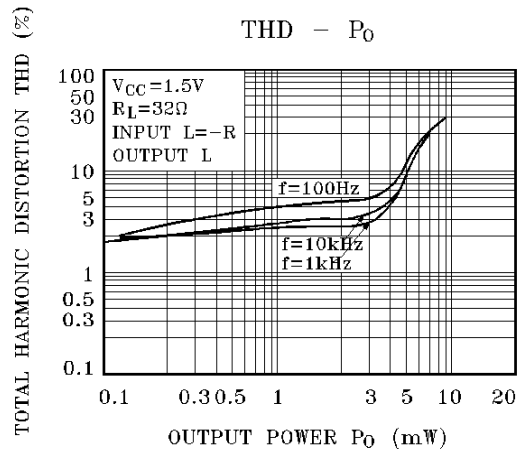

THD - P_0

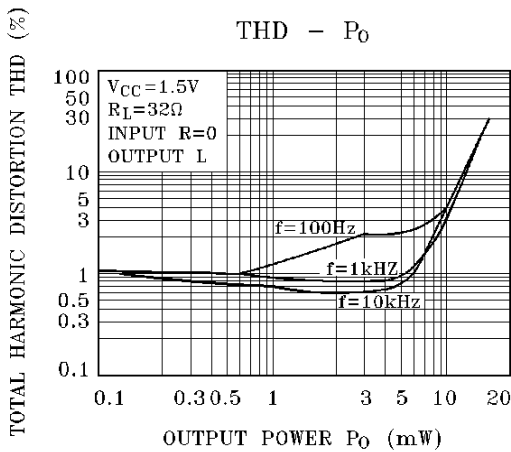

I_{CCQ} - T_a

