

STEREO SOUND CONTROL SYSTEM

The KIA6930P is DC controlled dual volume, balance, tone (bass, treble) IC. As these dual channels are constructed on one chip, this IC is excellent in pair characteristic. It is suitable for car stereo, radio cassette, music center, TV multiplex sound receiver and remote controlled applications.

FEATURES

- Wide Power Supply Voltage Range:
Single Supply $V_{CC(opr)}=8\sim 14V$
Dual Supply $V_{CC}-V_{EE(opr)}=\pm 4\sim \pm 7V$.
- Wide Volume Control Range : $V_R=80dB(Typ.)$.
- Excellent Cross Talk : $C.T=70dB(Typ.)$.
- Stable for Temperature Drift.
- Wide Tone Control Range
Control Range : $V_B=10dB(Typ.)$ at $f=1kHz\rightarrow 100Hz$
 $V_T=12dB(Typ.)$ at $f=1kHz\rightarrow 20kHz$.

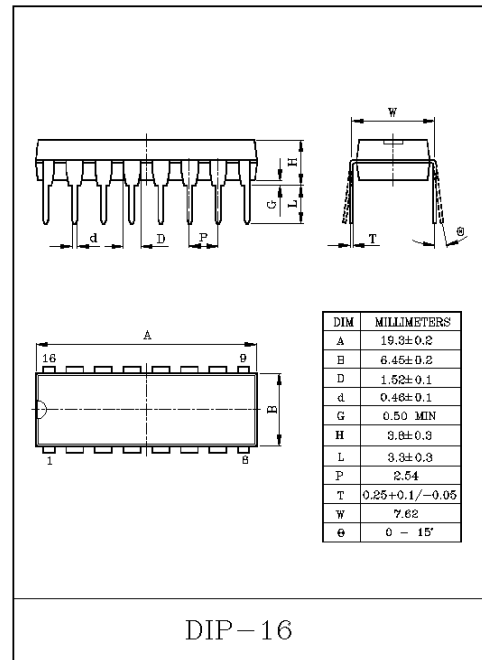

MAXIMUM RATINGS (Ta=25°C)

CHARACTERISTIC	SYMBOL	RATING	UNIT
Supply Voltage	V_{CC}	14	V
Power Dissipation (Note)	P_D	750	mW
Operating Temperature	T_{opr}	-25~75	°C
Storage Temperature	T_{stg}	-55~150	°C

Note : Derated above $T_a=25^\circ C$ in the proportion of $6mW/^\circ C$ for KIA6930P.

KIA6930P

ELECTRICAL CHARACTERISTICS

(Unless otherwise specified, $V_{CC}=6V$, $V_{EE}=-6V$, $f=1kHz$, $T_a=25^{\circ}C$)

CHARACTERISTIC	SYMBOL	TEST CIRCUIT	TEST CONDITION	MIN.	TYP.	MAX.	UNIT
Quiescent Current	$I_{CCQ(1)}$	-	VOL/BAL/BASS/ SW1~4:B $V_{CC}, V_{EE} = \pm 4V$	-	11	17	mA
	$I_{CCQ(2)}$	-	$V_{CC}, V_{EE} = \pm 6V$	10	18	25	
Maximum Input Voltage	V_{IN}	-	BASS/TRBL/BAL SW1~3:B	1	-	-	V_{rms}
Maximum Output Voltage	V_{OUT}	-	VOL SW4:A, THD=1%	1	-	-	V_{rms}
Voltage Gain	G_V	-	BASS/TRBL/BAL SW1~3:B	-0.5	2.0	4.5	dB
Channel Balance	C.B-1	-	$V_{IN}=1V_{rms}$, VOL SW4:A	-3	0	3	dB
	C.B-2	-	VOL/BAL/BASS/TRBL SW1~4:B $V_{IN}=0.1V_{rms}$, $f=100Hz \sim 20kHz$	-3.5	0	3.5	
Volume Control Range	V_R	-	BASS/TRBL/BAL SW1~3:B VOL SW4:A→C, $V_{IN}=1V_{rms}$	70	80	-	dB
Bass Control Range	V_B MAX	-	VOL/BAL SW3,4:B $V_{IN}=1V_{rms}$, $f=1kHz \rightarrow 100Hz$	7	11	14	dB
	V_B MIN	-	BASS/TRBL SW1,2:C	-15	-11.5	-7	
Treble Control Range	V_T MAX	-	VOL/BAL SW3,4:B $V_{IN}=1V_{rms}$, $f=1kHz \rightarrow 20kHz$	7	11	14	dB
	V_T MIN	-	BASS/TRBL SW1,2:C	-20	-14	-10	
Tone Error	ΔG_V	-	VOL/BAL SW3, 4:B, $V_{IN}=1V_{rms}$ BASS/TRBL SW1, 2:C→A	-	6	10	dB
Total Harmonic Distortion	THD	-	BASS/TRBL/BAL SW1~3:B, VOL SW4:A, $V_O=150mV_{rms}$	-	0.1	0.35	%
Output Noise Voltage	V_{NO}	-	BASS/TRBL/BAL SW1~3:B VOL SW4:A, BW=50Hz~20kHz INPUT OPEN	-	130	300	μV_{rms}
Cross Talk	C.T	-	BASS/TRBL/BAL SW1~3:B VOL SW4:A, $V_{OUT}=1V_{rms}$	-	70	-	dB
Control Terminal Input Resistance	R_{IN}	-	⑧, ⑨, ⑩ PIN	-	500	-	k Ω
			⑦ PIN	-	200	-	

KIA6930P

TEST CIRCUIT / BLOCK DIAGRAM

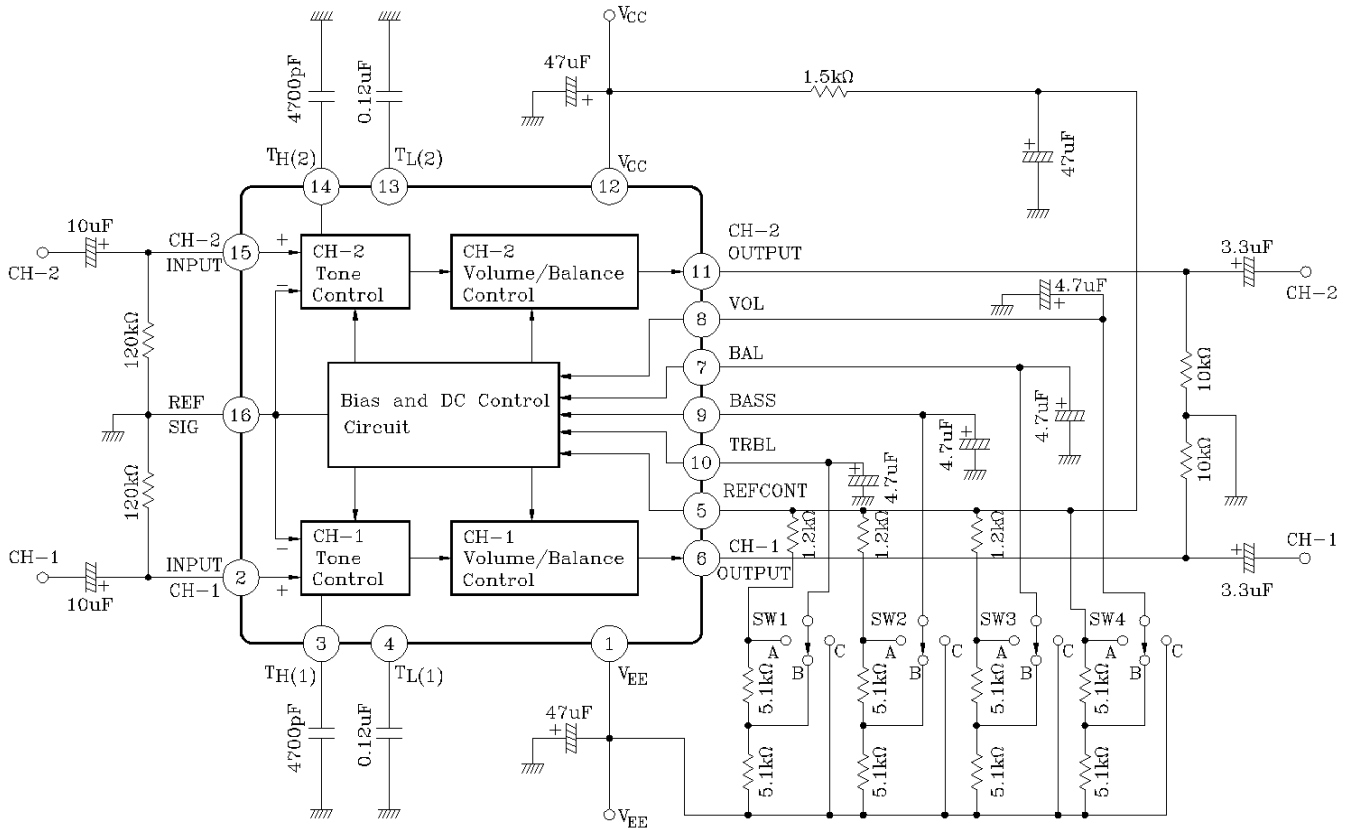

PIN CONNECTION

PIN NO.	SYMBOL	EXPLANATION	PIN NO.	SYMBOL	EXPLANATION
1	V _{EE}	Negative Power Supply	9	BASS	Bass Control
2	INPUT-1	Input channel-1	10	TRBL	Treble Control
3	TH(1)	Treble Turning Frequency Setting.	11	OUTPUT-2	Output Channel-2
4	TL(1)	Bass Turning Frequency Setting.	12	V _{CC}	Power Supply
5	REF CONT	Reference Control	13	T _L (2)	Bass Turning Frequency Setting
6	OUTPUT-1	Output Channel-1	14	T _H (2)	Treble Turning Frequency Setting
7	BAL	Balance Control	15	INPUT-2	Input Channel-2
8	VOL	Volume Control	16	REF SIG	Reference Signal

KIA6930P

APPLICATION CIRCUITS

1. SINGLE POWER SUPPLY

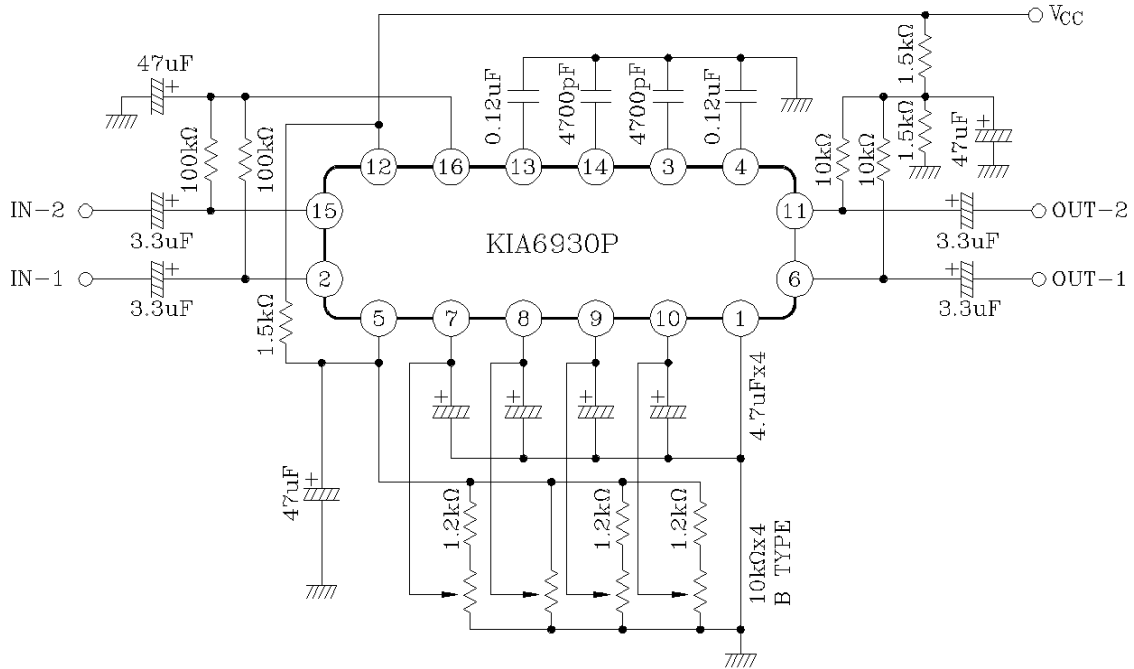

2. DUAL POWER SUPPLY

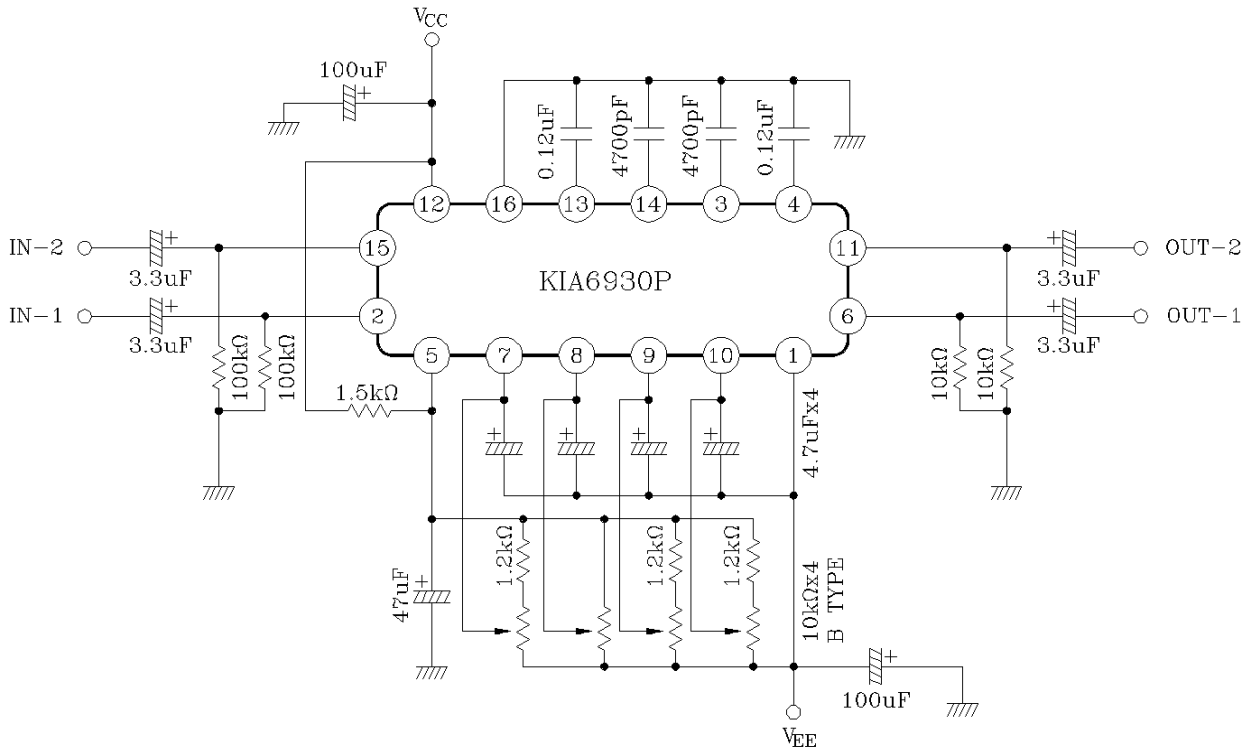

KIA6930P

3. APPLICATION CIRCUIT USING DIODE AT REFERENCE TERMINAL

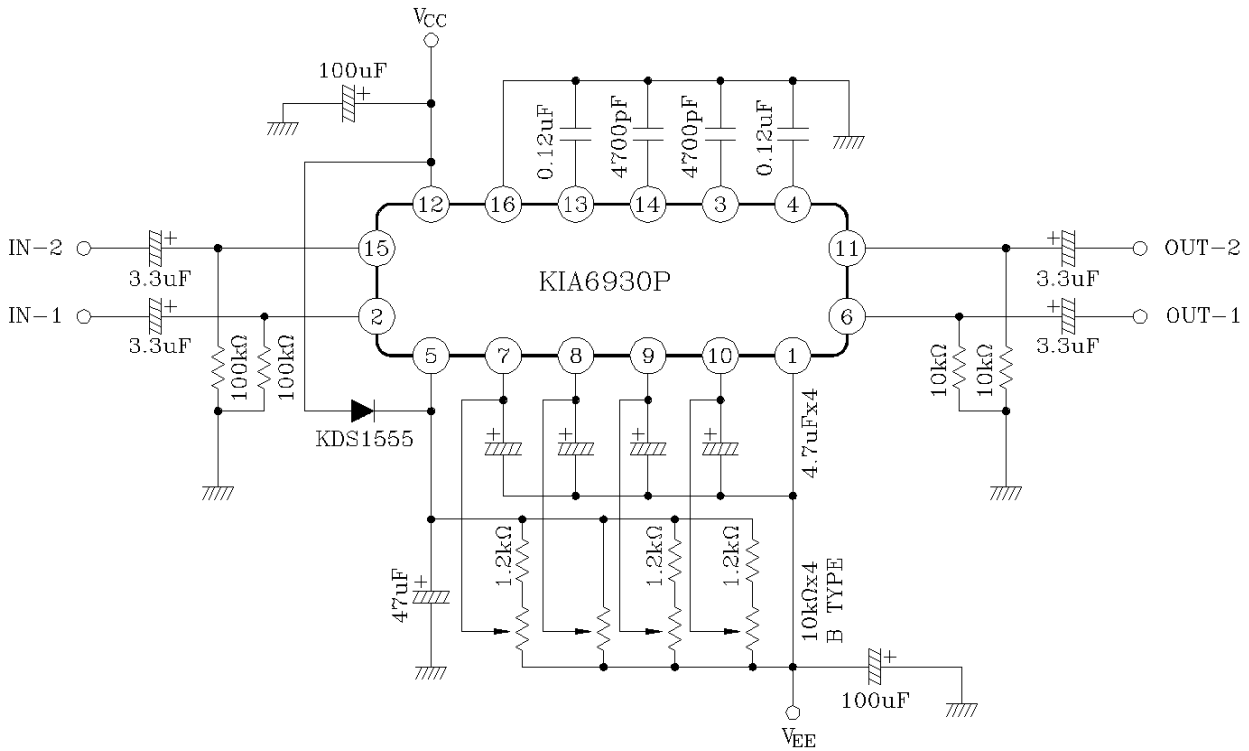

The application circuit using diode between pin⑤ and Pin⑫ has the following merits.

- 3-1. When each control terminal is driven by high impedance, the electrolytic capacitor between terminal ⑤ and GND operates as the back up capacitor, so that the rise time is short at the ON-OFF repetition of supply voltage.
- 3-2. When the current drain into the each control terminal varies by control voltage, the voltage of terminal ⑤ scarcely varies. It means a stable reference voltage.

KIA6930P

4. QUASI-LOUDNESS CIRCUIT

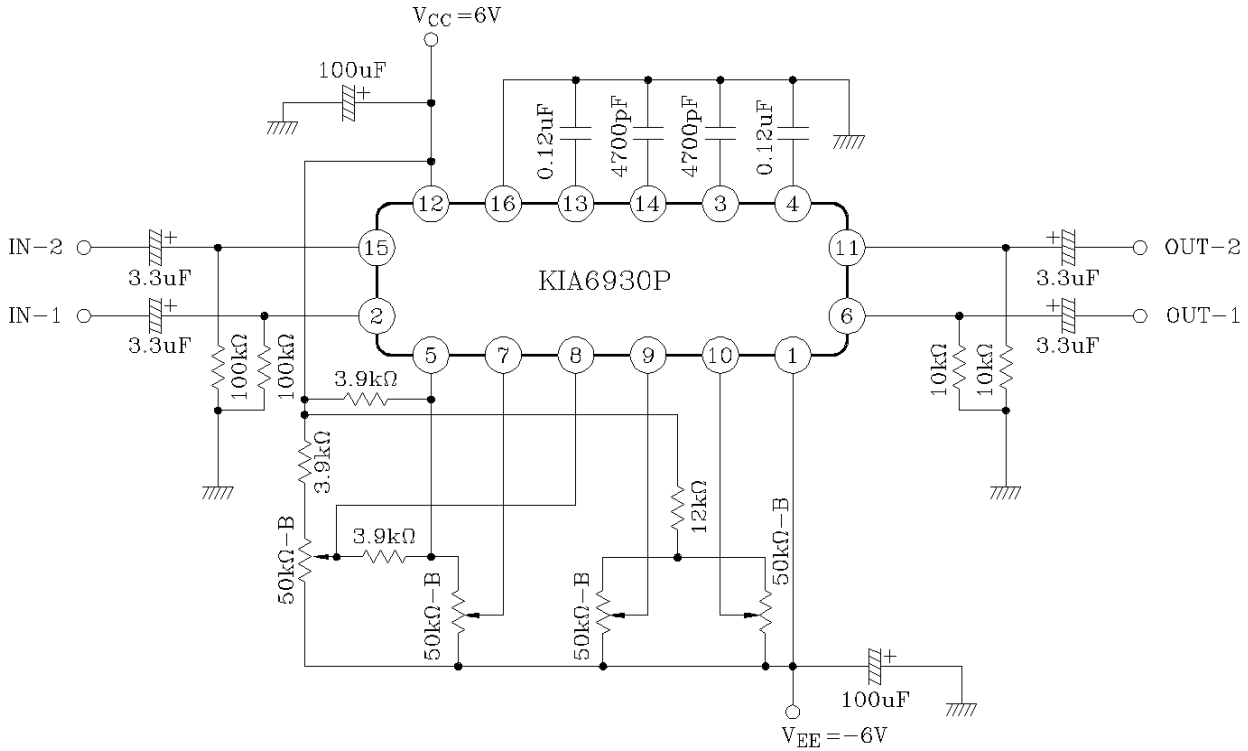

OUTPUT - f

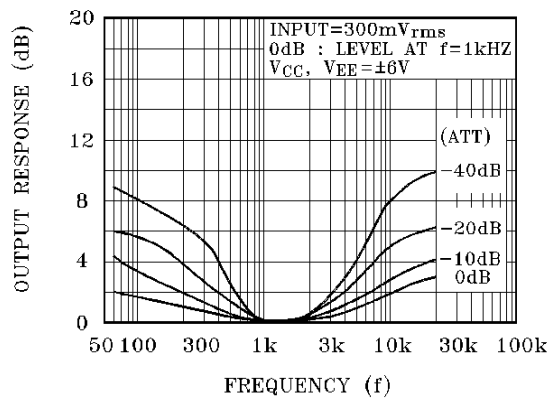

KIA6930P

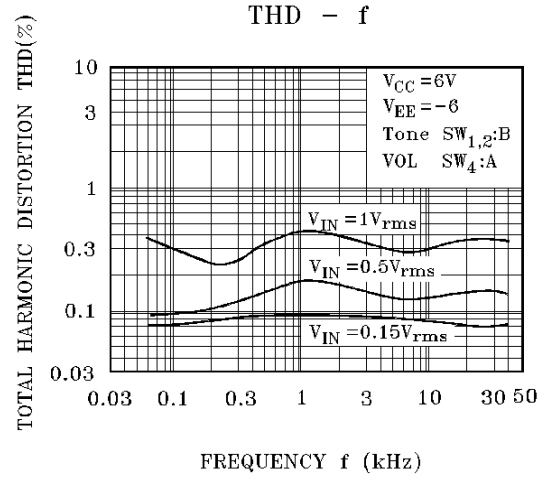
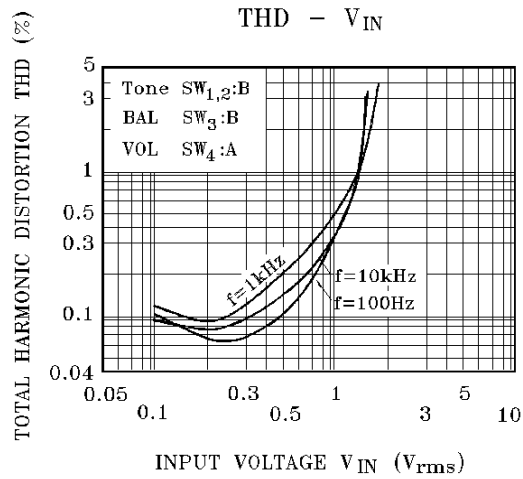
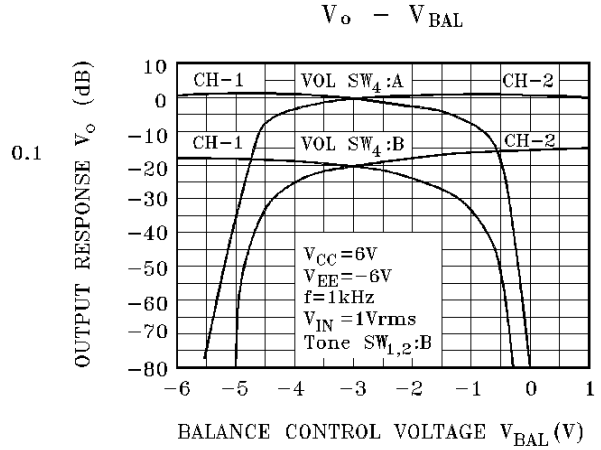
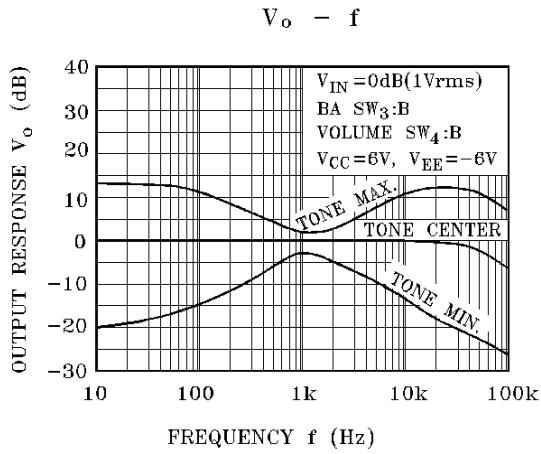

KIA6930P

