

GENERAL PURPOSE SWITCHING REGULATOR.

The KIA494APV/AFV is an IC for switching regulator, with 5V reference voltage, built-in error amplifier, saw tooth wave generating circuit, dead time adjusting comparator, flip-flop, and output buffer.

FEATURES

- Wide Same Phase Range of the Error Amplifier.
- Built-in 250mA/100mA Output Buffer.
- Dead Time is Adjustable.
- Built-in Low Supply Voltage Protective Circuit.

MAXIMUM RATINGS (Ta=25°C)

ITEM		SYMBOL	RATING	UNIT
Supply Voltage	KIA494APV	V _{CC}	41	V
	KIA494AFV		25	
Error Amplifier Input Voltage		V _{ICM}	V _{CC} +0.3	V
Output Voltage	KIA494APV	V _{CER}	41	V
	KIA494AFV			
Output Current	KIA494APV	I _C	250	mA
	KIA494AFV		100	
Power Consumption	KIA494APV	P _D	750	mW
	KIA494AFV		400	
Operating Temperature		T _{opr}	-40~85	°C
Storage Temperature		T _{stg}	-55~150	°C

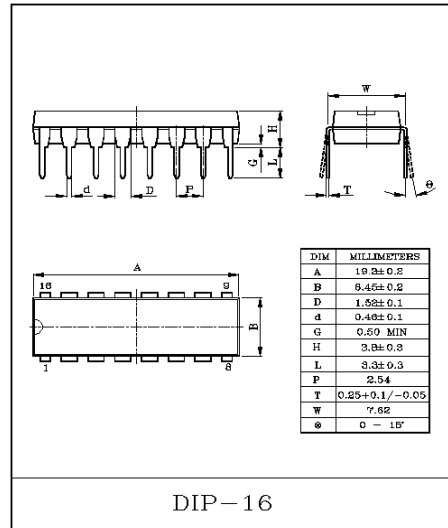

DIP-16

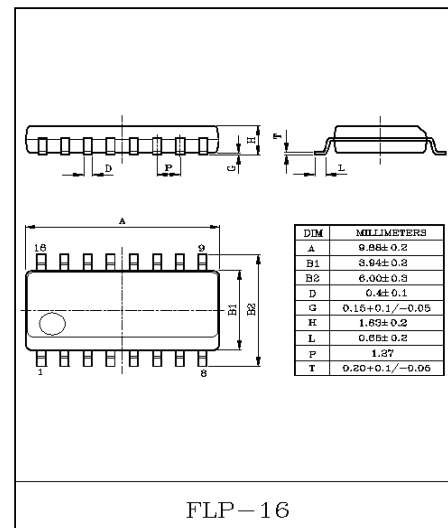

FLP-16

RECOMMENDED OPERATING CONDITIONS

ITEM		SYMBOL	MIN.	TYP.	MAX.	UNIT
Supply Voltage	KIA494APV	V _{CC}	7	-	40	V
	KIA494AFV				25	
Output Voltage	KIA494APV	V _{CER}	-0.3	-	40	V
	KIA494AFV					
Output Current (per one stage of output unit)	KIA494APV	I _C	-	-	200	mA
	KIA494AFV				100	
Error Amplifier Sink Current		I _{OAMP}	-	-	-0.3	mA
Timing Capacitor		C _T	0.47	-	10,000	nF
Timing Resister		R _T	1.8	-	500	kΩ
Oscillation Frequency		f _{osc}	1	-	300	kHz
Operating Temperature		T _{opr}	-20	-	70	°C

KIA494APV/AFV

ELECTRICAL CHARACTERISTICS REFERENCE VOLTAGE UNIT

CHARACTERISTIC	SYMBOL	TEST CONDITION	MIN.	TYP.	MAX.	UNIT
Output Voltage	V_{ref}	$I_{ref}=1mA, T_a=25^{\circ}C$	4.75	5.00	5.25	V
Input Stability	$R_{eg IN}$	$7V \leq V_{CC} \leq 25V,$ $I_{ref}=1mA, T_a=25^{\circ}C$	-	8	25	mV
Load Stability	$R_{eg L}$	$1mA \leq I_{ref} \leq 10mA, T_a=25^{\circ}C$	-	1	15	
Output Voltage Temp. Change	$T_c V_{ref}$	$-40^{\circ}C \leq T_a \leq 85^{\circ}C, I_{ref}=1mA$	-	0.01	0.03	%/ $^{\circ}C$
Output Short-Circuit Current	I_S	$V_{ref}=0$	-	50	-	mA

OSCILLATION UNIT

CHARACTERISTIC	SYMBOL	TEST CONDITION	MIN.	TYP.	MAX.	UNIT
Oscillation Frequency Set Value	f_{osc}	$C_T=0.001\mu F, R_T=30k\Omega$	-	40	-	kHz
Oscillation Frequency Setting Accuracy	f_{DIV}	$C_T=0.001\mu F, R_T=30k\Omega$	-	3.0	-	
Frequency Input Stability	f_{VIN}	$7V \leq V_{CC} \leq 25V, T_a=25^{\circ}C$	-	0.1	-	%
Frequency Temp. Change	f_{Ta}	$0^{\circ}C \leq T_a \leq 70^{\circ}C$	-	1	2	

PAUSE PERIOD ADJUSTING UNIT

CHARACTERISTIC	SYMBOL	TEST CONDITION	MIN.	TYP.	MAX.	UNIT
Input Bias Current	I_{IND}	$0 \leq V_{IN} \leq 5.25V$ PIN 4	-	-2	-10	A
Max. Duty (Each Output Stage)	D_y MAX.	$V_{IN}=0, C_T=0.1\mu F,$ $R_T=12k\Omega$	45	48	-	%
Input Threshold Voltage 1	V_{TH-1}	Output pulse 0% duty	-	2.8	3.3	V
Input Threshold Voltage 2	V_{TH-2}	Output pulse max. duty	0	-	-	

ERROR AMPLIFIER I, II

CHARACTERISTIC	SYMBOL	TEST CONDITION	MIN.	TYP.	MAX.	UNIT
Input Offset Voltage	V_{IO}	V_O PIN 3=2.5V	-	2	10	mV
Input Offset Current	I_{IO}	V_O PIN 3=2.5V	-	5.0	250	nA
Input Bias Current	I_B	V_O PIN 3=2.5V	-	0.1	1	A
In-phase Input Voltage Range	CMR_{IN}	$7V \leq V_{CC} \leq 25V$	0.3	-	$V_{CC}-2$	V
Open Load Gain	G_V	V_O PIN 3=0.5~3.5V, $R_L=2k\Omega$	70	95	-	dB
Unity Gain Frequency	f_o	V_O PIN 3=0.5~3.5V, $R_L=2k\Omega$	-	350	-	kHz
In-phase Signal Removing Ratio	$CMRR$	$V_{CC}=25V$	65	90	-	dB
Output Sink Current	I_{O+}	V_O PIN 3=0.7V	0.3	0.7	-	mA
Output Source Current	I_{O+}	V_O PIN 3=3.5V	-2	-10	-	

KIA494APV/AFV

PWM COMPARATOR

CHARACTERISTIC	SYMBOL	TEST CONDITION	MIN.	TYP.	MAX.	UNIT
Input Threshold Voltage	V_{TH}	Zero duty cycle	-	4	4.5	V
Input Sink Current	I_I	V_O PIN 3=0.7V	0.3	0.7	-	mA

OUTPUT UNIT

CHARACTERISTIC	SYMBOL	TEST CONDITION	MIN.	TYP.	MAX.	UNIT	
Collector Cut-off Current	I_{CER}	$V_{CE}=25V$, $V_{CC}=25V$ Emitter grounded	-	-	100	μA	
Emitter Cut-off Current	$I_{E(OFF)}$	$V_{CC}=V_C=25V$, $V_E=0V$ Emitter follower	-	-	-100		
Emitter Saturation Voltage (Emitter grounded)	$V_{SAT(C)}$	$I_C=50mA$, $V_E=0V$	-	0.95	1.3	V	
Collector Saturation Voltage (Emitter follower)	$V_{SAT(E)}$	$I_E=-50mA$, $V_C=15V$	-	1.6	2.5		
Output Voltage Rise Time (Emitter grounded)	t_{r1}		-	100	200	nS	
Output Voltage Fall Time (Emitter follower)	t_{f1}		-	25	100		
Output Voltage Rise Time (Emitter follower)	t_{r2}		-	100	200		
Output Voltage Fall Time (Emitter grounded)	t_{f2}		-	40	100		
Output Control Input Operating Current	"L" State	I_{OCL}	$V_{OC} \leq 0.4V$	-	10	-	μA
	"H" State	I_{OCH}	$V_{OC}=V_{ref}$	-	0.2	3.5	mA

CURRENT CONSUMPTION (TOTAL)

CHARACTERISTIC	SYMBOL	TEST CONDITION	MIN.	TYP.	MAX.	UNIT
Standby Current	$I_{CC(S \cdot B)}$	$V_{CC}=15V$, Other terminal opened	-	8	12.5	mA
Bias Current	$I_{CC \text{ total}}$	$V_{(PIN4)}=2V$, $C_T=0.01\mu F$ $R_T=12k\Omega$, $V_{CC}=15V$	-	10	-	

KIA494APV/AFV

BLOCK DIAGRAM

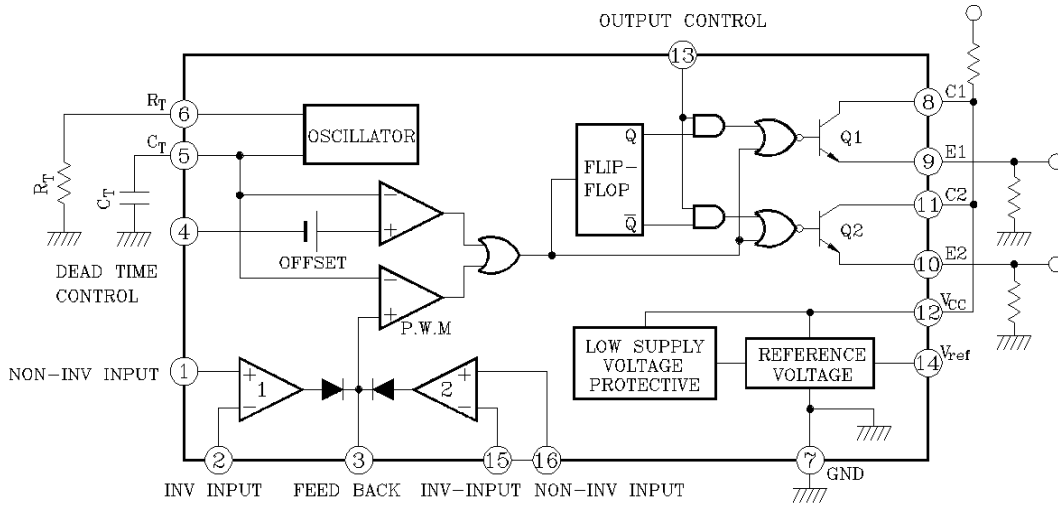

(Note) PIN ⑬ BECOMES SINGLE MODE AT "L" AND PUSH-PULL MODE AT "H"

OPERATING WAVEFORM

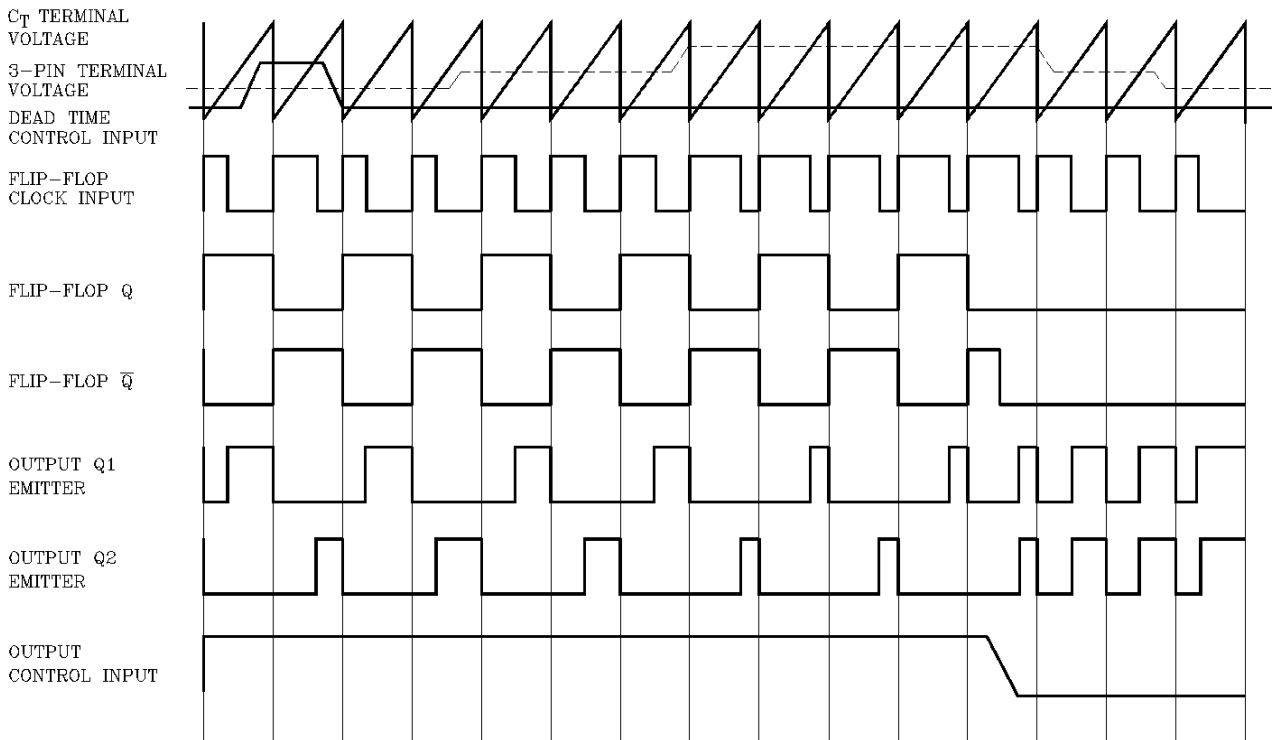

KIA494APV/AFV

