

SINGLE OPERATIONAL AMPLIFIER

- In the Linear Mode the Input Common Mode Voltage Range Includes Ground.
- Low Power Dissipation and Power Drain Suitable for Battery Operation.
- Differential Input Voltage Range Equal to the Power Supply Voltage.
- Wide Power Supply Voltage Range and Signal Power Supply : Single Supply $3V_{DC}$ to $36V_{DC}$
Dual Supplies $\pm 1.5V_{DC}$ to $\pm 18V_{DC}$
- Large Output Voltage Swing : $0V_{DC}$ to $V_{CC}-1.5V_{DC}$
- Low Input Biasing Current : $I_I=45nA_{DC}$ (Typ.)

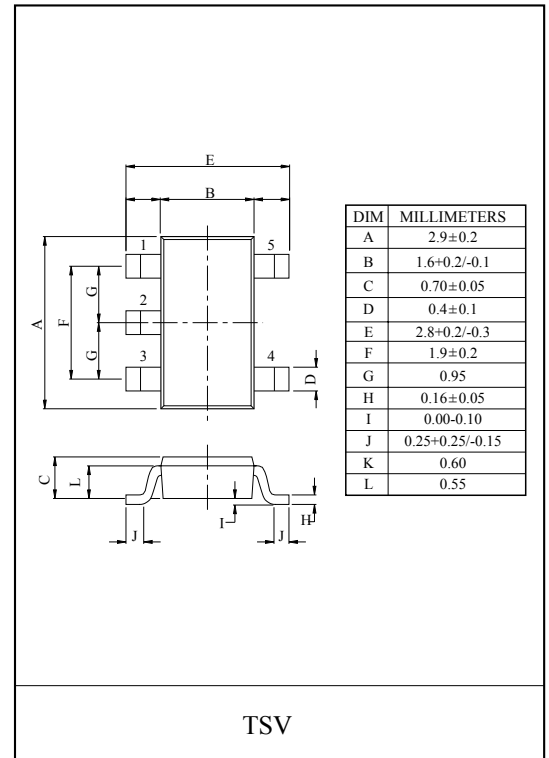

PIN CONNECTION (TOP VIEW)

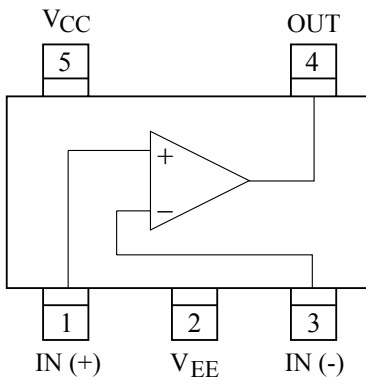

Marking (TOP VIEW)

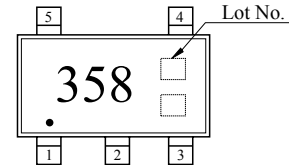

MAXIMUM RATING (Ta=25°C)

CHARACTERISTIC	SYMBOL	RATING	UNIT
Supply Voltage	V_{CC}	36, +18	V
	V_{EE}	0, -18	
Differential Input Voltage	DV_{IN}	± 36	V
Input Voltage	V_{IN}	-0.3 ~ 36	V
Power Dissipation	P_D	200	mW
Operating Temperature	T_{opr}	-40 ~ 85	°C
Storage Temperature	T_{stg}	-55 ~ 125	°C

KIA75S358F

EQUIVALENT CIRCUIT

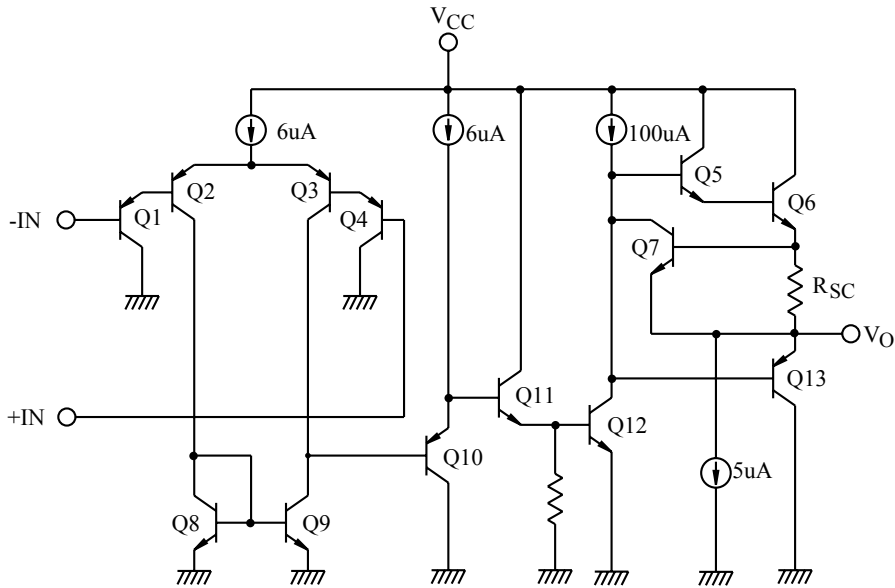

ELECTRICAL CHARACTERISTICS ($V_{CC}=5V$, $V_{EE}=GND$, $T_a=25^\circ C$)

CHARACTERISTIC	SYMBOL	TEST CONDITION	MIN.	TYP.	MAX.	UNIT
Input Offset Voltage	V_{IO}	$R_g \leq 10k\Omega$	-	2	7	mV
Input Offset Current	I_{IO}	-	-	5	30	nA
Input Bias Current	I_I	-	-	45	150	nA
Common Mode Input Voltage	CMV_{IN}	$V_{CC}=30V$, $V_{EE}=GND$	0	-	$V_{CC}-1.5$	V
Supply Current	I_{CC} , I_{EE}	$R_L=\infty$, All OP Amps	-	0.4	0.8	mA
Voltage Gain	G_V	$R_L \geq 2k\Omega$	86	100	-	dB
Maximum Output Voltage Swing	V_{OP-P}	$R_L=2k\Omega$	0	$V_{CC}-1.5$	-	V
Common Mode Input Signal Rejection Ratio	CMRR	-	60	85	-	dB
Supply Voltage Rejection Ratio	SVRR	$R_g=10k\Omega$	60	100	-	dB
Source Current	I_{source}	$-IN=0V_{DC}$, $+IN=1V_{DC}$	20	40	-	mA
Sink Current	I_{sink}	$-IN=1V_{DC}$, $+IN=0V_{DC}$	10	20	-	mA

KIA75S358F

$V_{CC} - I_{CC}$

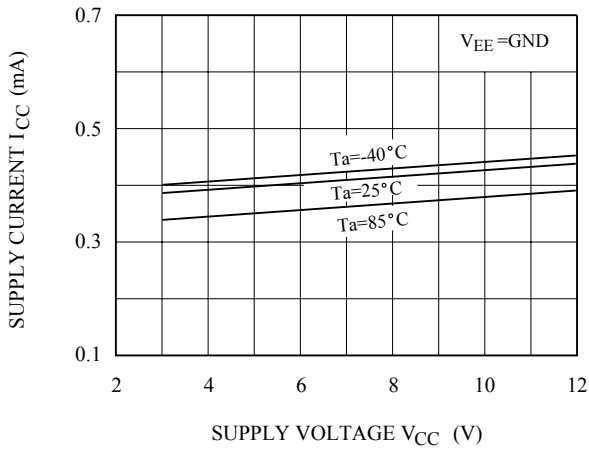

$V_{CC} - I_I$

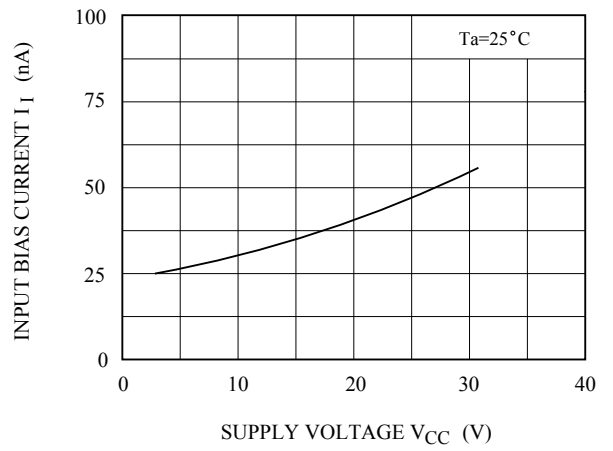

$V_{CC} - G_V$

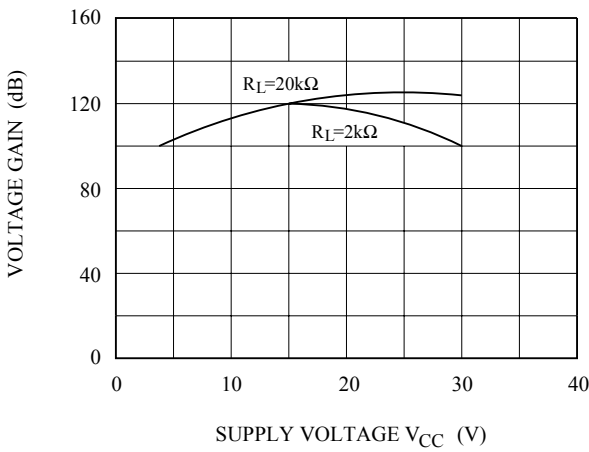

$I_{SOURCE} - T_a$

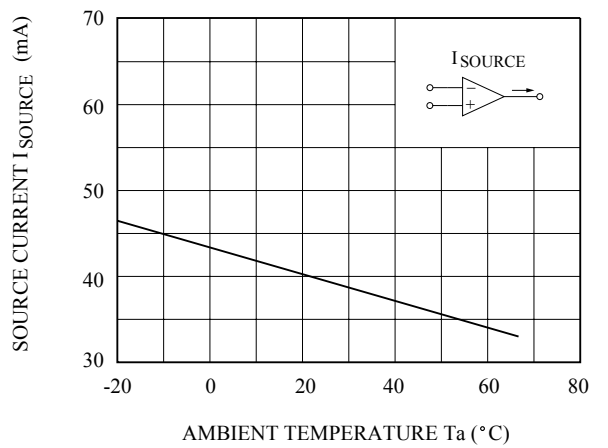

CMRR - f

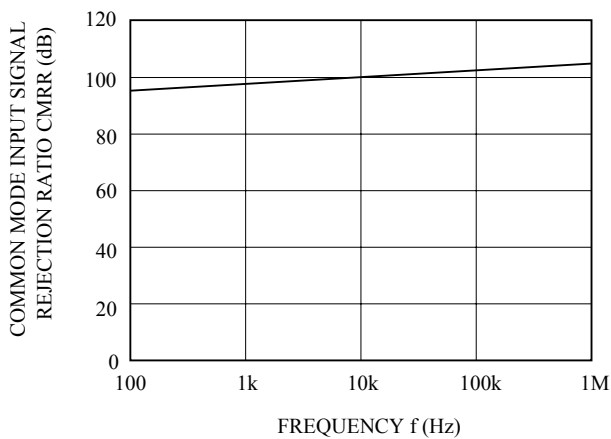

$G_V - f$

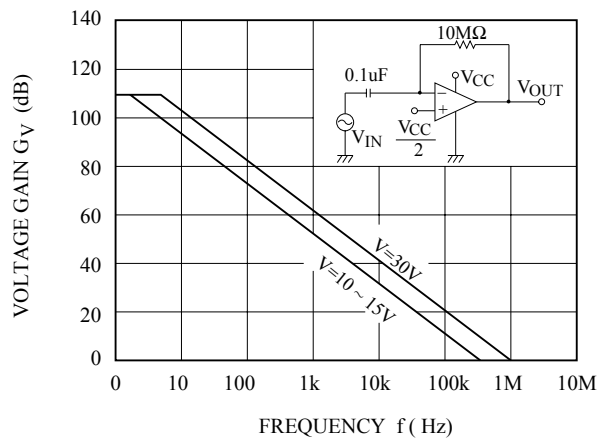

KIA75S358F

