

3 TERMINAL LOW DROP OUTPUT VOLTAGE REGULATOR

The KIA78DXXF Series are fixed positive output low drop out type, 3-pin voltage regulators with positive output.

These regulators are used to provide a stabilized output voltage from a fluctuating DC input voltage.

These are 12 fixed output voltage, as follows ; 2.5V, 3.0V, 3.3V, 3.5V, 3.7V, 5V, 6V, 8V, 9V, 10V, 12V, and 15V.

The maximum current capacity is 1A for each of the above voltage.

FEATURES

- Built in over voltage protection circuit, over current protection circuit and thermal shut down circuit.
- Compatible with the KIA78DXXF Series.
- Richly diverse Lineup.
- Low minimum I/O voltage differential.

LINE UP

ITEM	OUTPUT VOLTAGE (Typ.)	UNIT
* KIA78D25F	2.5	V
* KIA78D30F	3.0	
KIA78D33F	3.3	
* KIA78D35F	3.5	
* KIA78D37F	3.7	
KIA78D05F	5	
KIA78D06F	6	
KIA78D08F	8	
KIA78D09F	9	
KIA78D10F	10	
KIA78D12F	12	
KIA78D15F	15	

Note) * : Under development.

MAXIMUM RATINGS (Ta=25 °C)

CHARACTERISTIC	SYMBOL	RATING	UNIT	Remark
Input Voltage	V_{IN}	35	V	-
Output Current	I_O	1	A	-
Power Dissipation	P_d	1.3	W	No heatsink
Junction Temperature	T_j	125	°C	-
Operating Temperature	T_{opr}	-40 ~ 85	°C	-
Storage Temperature	T_{stg}	-50 ~ 150	°C	-
Soldering Temperature (10sec)	T_{sol}	260	°C	-

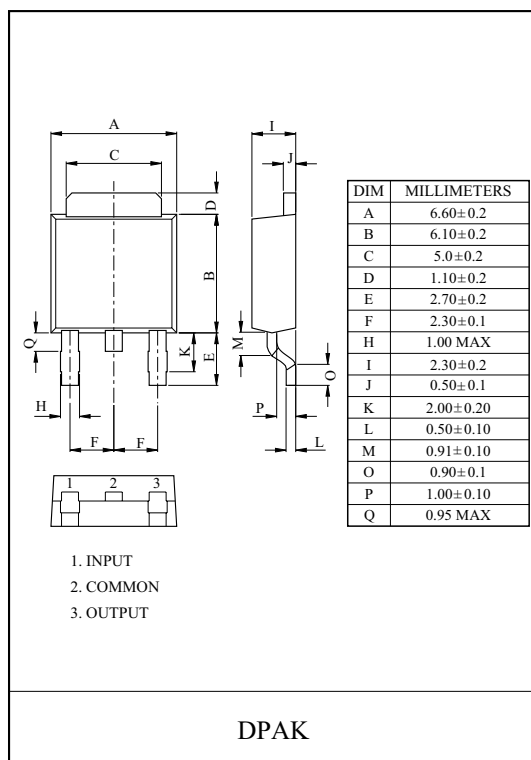

KIA78D25F~78D15F

ELECTRICAL CHARACTERISTICS (Unless otherwise specified, $I_O=0.5A$, $T_a=25^\circ C$, Note1.)

CHARACTERISTIC	SYMBOL	CONDITIONS	MIN.	TYP.	MAX.	UNIT
Output Voltage	KIA78D25	-	2.438	2.50	2.562	V
	KIA78D30	-	2.925	3.00	3.075	
	KIA78D33	-	3.220	3.30	3.380	
	KIA78D35	-	3.413	3.50	3.587	
	KIA78D37	-	3.608	3.70	3.792	
	KIA78D05	-	4.88	5.0	5.12	
	KIA78D06	-	5.85	6.0	6.15	
	KIA78D08	-	7.80	8.0	8.2	
	KIA78D09	-	8.78	9.0	9.22	
	KIA78D10	-	9.75	10.0	10.25	
	KIA78D12	-	11.70	12.0	12.30	
	KIA78D15	-	14.70	15.0	15.30	
Load Regulation	Reg Load	$I_O=5mA \sim 1A$	-	0.1	2.0	%
Line Regulation	Reg Line	(Note 2)	-	0.5	2.5	%
Ripple Rejection	R · R		45	55	-	dB
Drop Out Voltage	V_D	(Note 3)	-	-	0.5	V
Quiescent Current	I_Q	$I_O=0$	-	-	10	mA

Note1) V_{IN} of KIA78D25=4.2V

" KIA78D30=4.7V

" KIA78D33=5.0V

" KIA78D35=5.2V

" KIA78D37=5.4V

" KIA78D05=7V

V_{IN} of KIA78D06=8V

" KIA78D08=10V

" KIA78D09=15V

" KIA78D10=16V

" KIA78D12=18V

" KIA78D15=21V

Note2) V_{IN} of KIA78D25=3.2 ~ 10V

" KIA78D30=3.7 ~ 10V

" KIA78D33=4.0 ~ 10V

" KIA78D35=4.2 ~ 10V

" KIA78D37=4.4 ~ 10V

" KIA78D05=6 ~ 12V

V_{IN} of KIA78D06=7 ~ 15V

" KIA78D08=9 ~ 25V

" KIA78D09=10 ~ 25V

" KIA78D10=11 ~ 26V

" KIA78D12=13 ~ 29V

" KIA78D15=16 ~ 32V

Note3) At $V_{IN}=0.95V_O$

BLOCK DIAGRAM

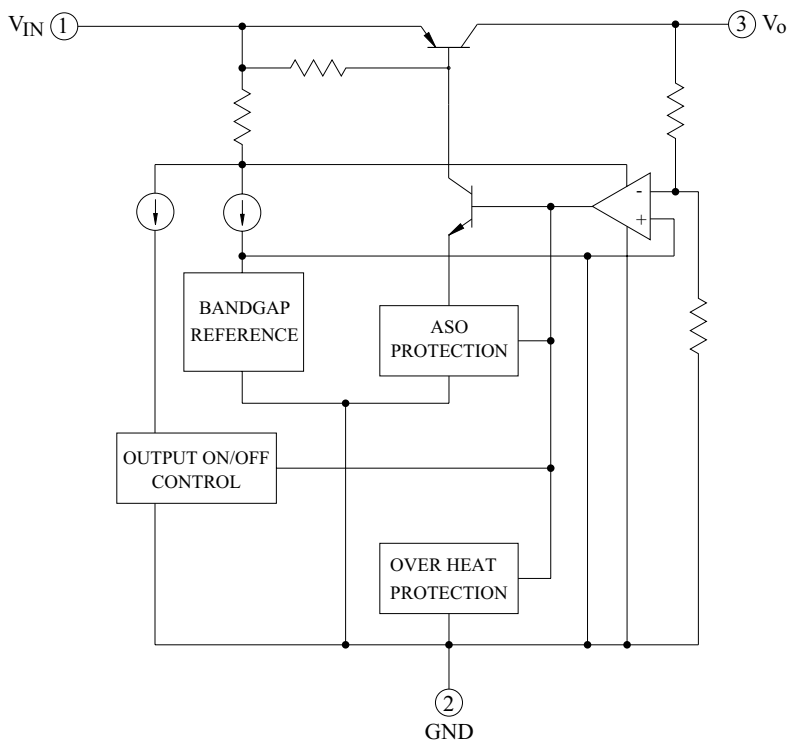

KIA78D25F~78D15F

Fig. 1 Standard Test Circuit

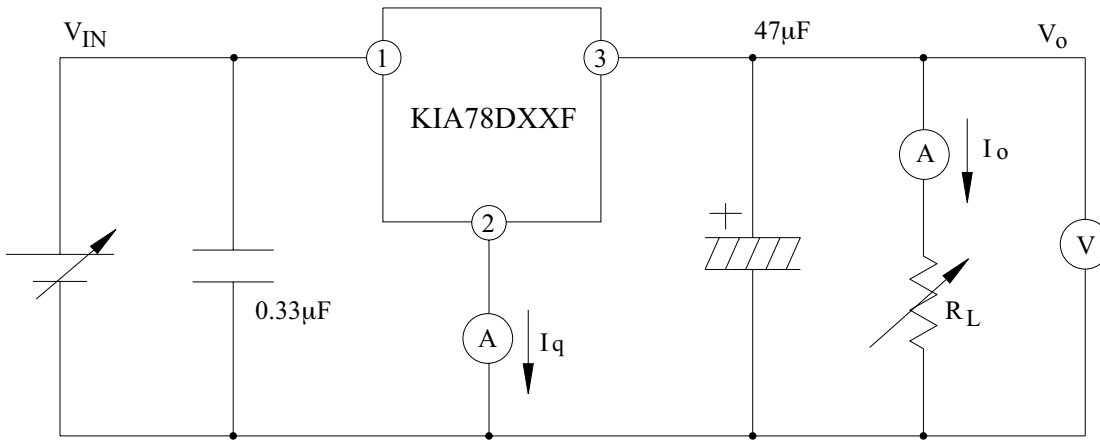

Fig. 1-2 Ripple Rejection Test Circuit

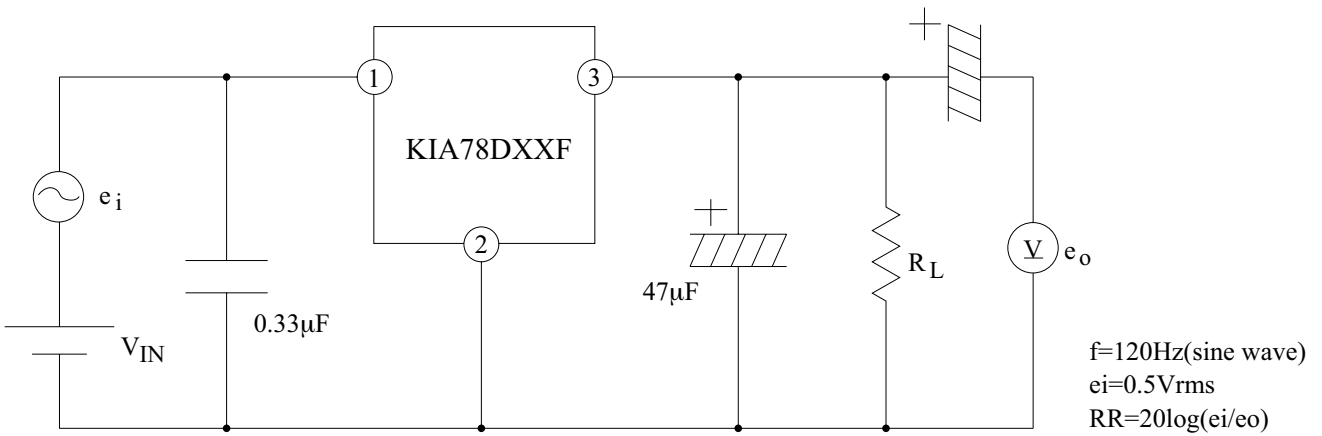
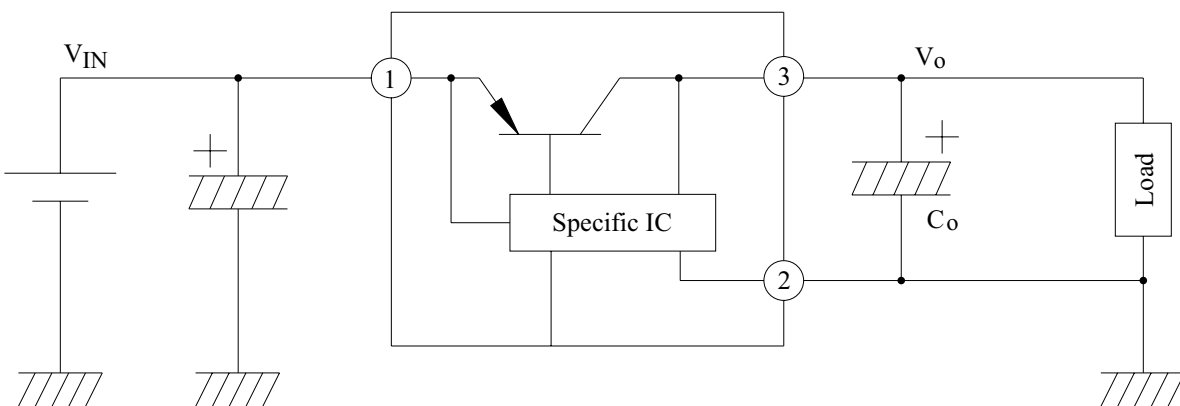

Fig. 2 Application Circuit for Standard



KIA78D25F~78D15F

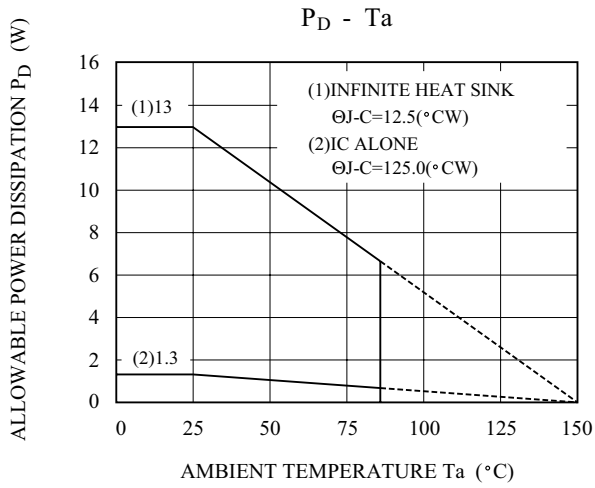

Fig 3. Power Dissipation Characteristics.

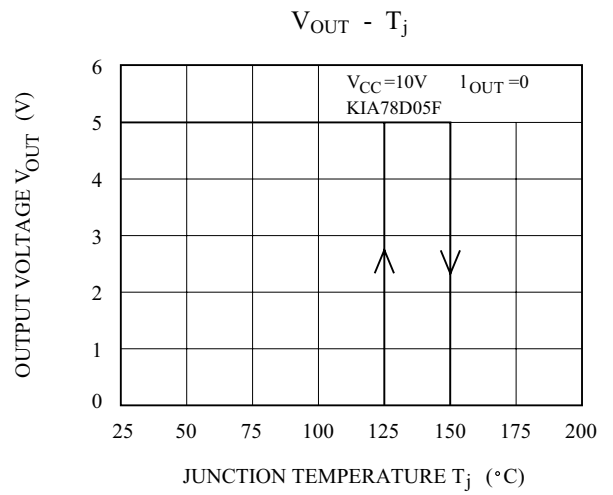

Fig 4. Thermal Cutoff Characteristics.

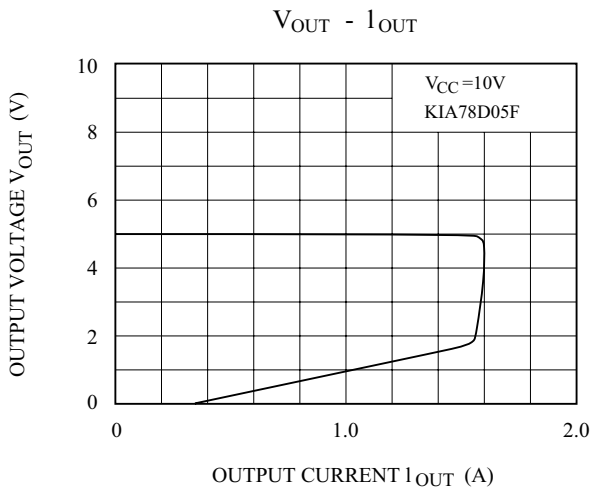

Fig 5. Current limit Characteristics.

