

White LED Step-Up Converter

The KIB3401F is a monolithic step-up DC/DC converter specifically designed to drive white LEDs with a constant current from Li-ion cell. Relative large 320mV feedback voltage & it's high accuracy help you setting LED current with a external resistor.

KIB3401F is available in a extremely low profile & small TS-6 package. A 10 μ H inductor is sufficient for most application.

FEATURES

- Inherently Matched LED Current.
- High Efficiency : 85% (max.)
- Built in a open circuits protection for the LEDs fail.
- Drives Up to four LEDs without external zener diode.
- Drives Up to six LEDs with external zener diode.
- Built in a N-channel MOSFET Switch.
- Fast 1.1MHz(typ.) Switching Frequency.
- Uses Tiny 1mm Tall Inductors.
- Built in Thermal protection.
- Wide Dimming control range : 25%~100%.
- Extremely low height & small Packaging.

APPLICATIONS

- Celluars Phones
- PDAs
- Digital Cameras
- MP3 Players, Color Displays

TYPICAL APPLICATION

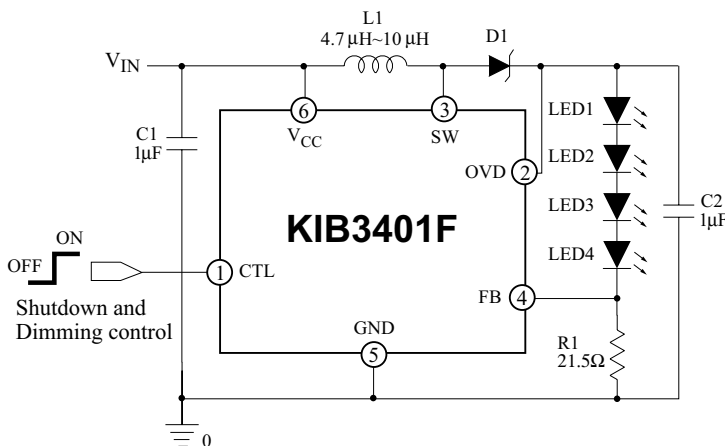

- C1, C2 : X5R OR X7R DIELECTRIC
 D1 : KEC KDR730E/KDR720E (Low V_F)
 L1 : MURATA LQH32CN100K53L OR EQUIVALENT

Figure1. 4Series White LED Driver in Thin TS6

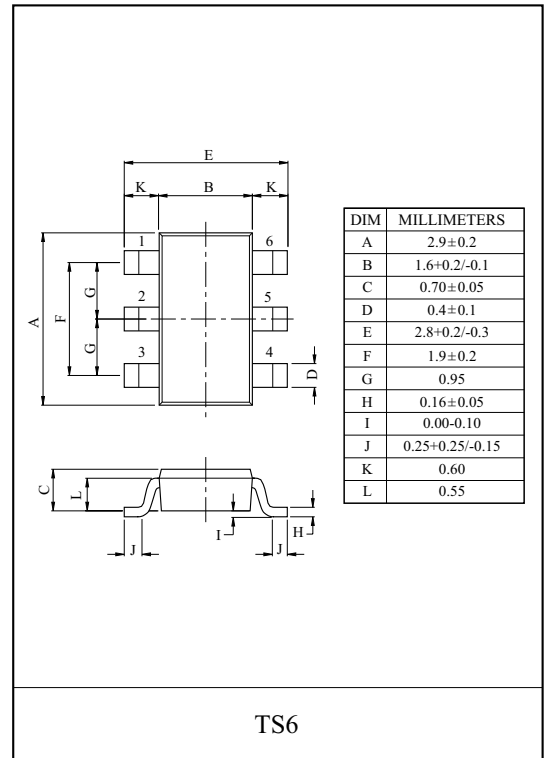

Marking

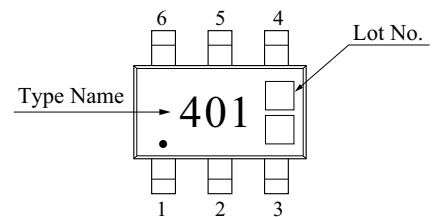

CONVERSION EFFICIENCY

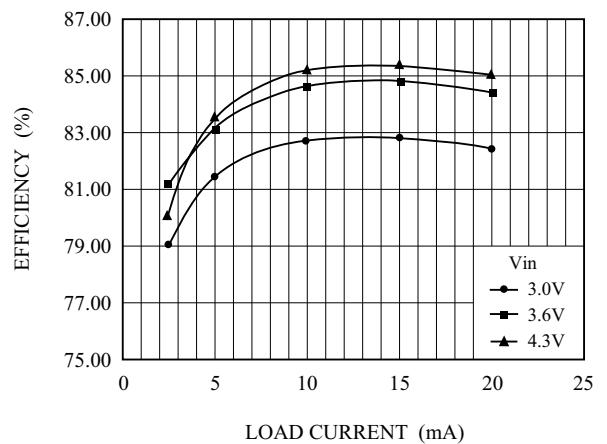

KIB3401F

BLOCK DIAGRAM

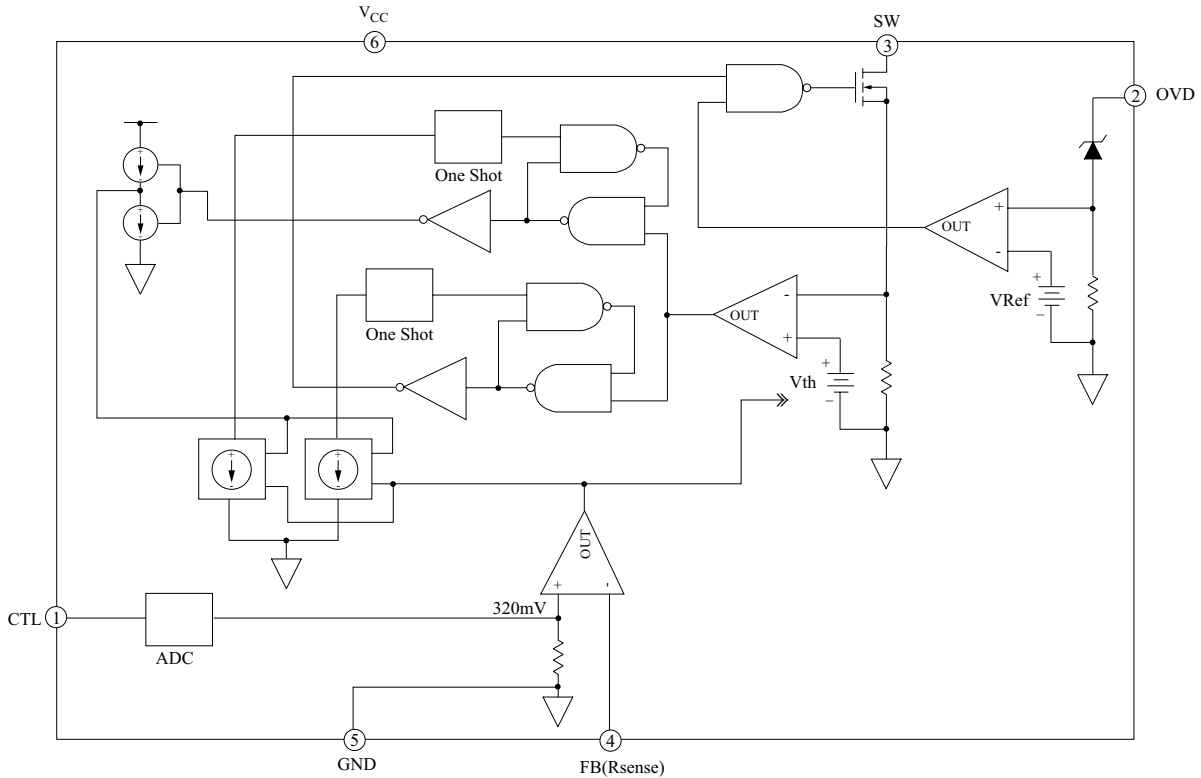

figure 2. KIB3401F Block Diagram

MAXIMUM RATINGS (Ta=25 °C)

CHARATERISTICS	SYMBOL	RATING	UNIT
Input Voltage	V_{CC}	-0.3 ~ 6.0	V
Switching pin Voltage	V_{SW}	-0.3 ~ 22	V
OVD pin Voltage	V_{OVD}	-0.3 ~ 22	V
Operating temperature range	T_{opr}	-40 ~ 85	°C
Storage temperature range	T_{stg}	-40 ~ 150	
Maximum Junction temperature	T_j	150	

RECOMMENDED OPERATING CONDITIONS (T_{opr}=-40~85 °C)

CHARATERISTICS	SYMBOL	CONDITION	MIN.	TYP.	MAX.	UNIT
Input Voltage	V_{CC}	-	2.8	-	5.5	V
CTL pin voltage for full LED current	$V_{CTL H}$	$V_{CC}=3.0V$	2.7	-	-	V
CTL pin voltage to shutdown chip	$V_{CTL L}$		-	-	0.5	V
CTL pin input pulse width	$t_{PW(CTL)}$	Both Positive and Negative pulse	33	-	-	μs
LED Current	IF	$V_{CC}=3.6V$, $R_{SENSE}=16 \Omega$, $T_{opr}=25 \text{ } ^\circ\text{C}$, Four LED	-	20	-	mA
CTL Response Delay (When Power ON.)	$T_{pd CTL}$	-	2	-	-	μs

KIB3401F

ELECTRICAL CHARACTERISTIC

(Topr=-40~85 °C, V_{CC}=2.8~5.5V, R_{SENSE}=16 Ω, unless otherwise noted.)

CHARATERISTICS	SYMBOL	CONDITION	MIN.	TYP.	MAX.	UNIT
Input Voltage	V _{CC}	-	2.8	-	5.5	V
Supply Current	I _{CC}	V _{CC} = 3.6V, V _{CTL} =3.6V	-	0.9	1.5	mA
		V _{CTL} = 0V	-	0.5	1	μA
Feedback Voltage	V _{FB}	V _{CC} =V _{CTL} =3.0V, T _{opr} = 25 °C, L =10μH	294	320	346	mV
CTL Pin Bias Current	I _{CTL}	V _{CC} = 3.0V, V _{CTL} = 3.0V	-	20	-	μA
Switching Frequency	f _{OSC}	V _{CTL} = 3.0V	0.77	1.1	1.43	MHz
Switching Pin Current	I _{O(SW)}		-	400	-	mA
Switch RDS(ON)	R _{ON}	I _{O(SW)} ≤ 400mA	-	0.7	1.5	Ω
Switch Leak Current	I _{OZ(SW)}	-	-	0.5	1	μA
OVD Pin Voltage	V _{OVD}	-	16	20	22	V
OVD Pin Leak Current	I _{OZ(OVD)}	-	-	0.5	1	μA
Thermal Shutdown	TSD	-	-	150	180	°C
Switching Pin OVP	V _{O(SW)}	-	25	-	-	V
CTL pin voltage for Full LED Current	V _{CTL H}	V _{CC} = 3.0V	2.7	-	-	V
CTL pin voltage to shutdown Chip	V _{CTL L}		-	-	0.5	V
Feedback Bias Current	I _{FB}	-	-	0.5	1	μA
Maximum Duty Cycle	D _{max}	-	85	90	-	%

PIN FUNCTIONS

NO.	SYMBOL	FUNCTION AND CONNECTION.
1	CTL	Control pin : Shutdown or dimming control. Connect external enable or dimming circuits. Shutdown mode (IF = 0) : V _{CTL} <1.0V Dimming control mode : (IF = 20% ~ 100%, depend on V _{CTL}) 1.0V < V _{CTL} < 2.5V, when V _{CTL} is above 2.5V IF keep its maximum value(100%). ※ Filtered PWM signal, above 33us of pulse width, can be used for dimming control.
2	OVD	Over output voltage detect pin. Connect cathode of schottky diode and anode of highest LED.
3	SW	Switch pin. Connect inductor/diode here. Minimize trace area at this pin to reduce EMI.
4	FB	Feedback pin. Reference voltage is 320mV. Connect cathode of lowest LED and resistor here.
5	GND	Ground pin. Connect directly to local ground plane,
6	V _{CC}	Input supply pin. Must be locally bypassed.

KIB3401F

APPLICATION INFORMATION

Inductor Selection

A 10 μ H inductor is sufficient for most application. The efficiency comparison of different value inductors help you design your application circuits.

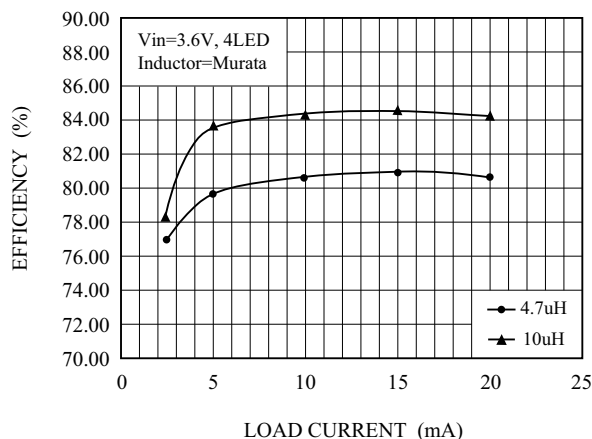

Figure3. Efficiency Comparison of different value inductors

Capacitor Selection

A 1 μ F input capacitor and output capacitor above 1 μ F are sufficient for most KIB3401F application.

Diode Selection

For Diode Selection, both forward voltage drop and diode capacitance need to be considered. Schottky diodes with higher current ratings usually have lower forward voltage and larger diode capacitance, which can cause significant switching losses. A schottky diode rated at 100mA to 200mA is sufficient for most KIB3401F applications.

Part No.	Reverse Voltage (V)	Forward Current (mA)	Voltage Drop (V)	Package
KDR730E	30	200 mA	0.6V (max) at 200 mA	
KDR720E	30	200 mA	0.5V(max) at 200 mA	
KDR412	20	500 mA	0.5V(max) at 500 mA	

Table 1. Recommended Schottky Diodes

LED Current Control

The LED current is controlled by the feedback resistor(RSENSE in Figure 1). The feedback reference is 320 mV.

The LED current is $320 \text{ mV} / R_{\text{SENSE}}$. The tolerance of LED Current is depends on tolerance of R_{SENSE} and feedback reference.

Open-Circuits Protection

In the case of output open circuit, when LEDs are disconnected from the circuit or the LEDs fail, the feedback voltage will be zero.

The KIB3401F will then switch at a high duty cycle resulting in a high output voltage, but Internal Over Voltage Protection Circuits prevent output voltage ascending over OVD pin voltage(16V ~ 22V see Fig.4). This circuit is valid when driving up to 4 LEDs in series. But, when driving more than 4 LEDs in series, Normal output voltage could be over OVD pin voltage.

In this case, zener diode can be used to limit output voltage, but check connection of OVD pin to VCC.(see Fig.5)

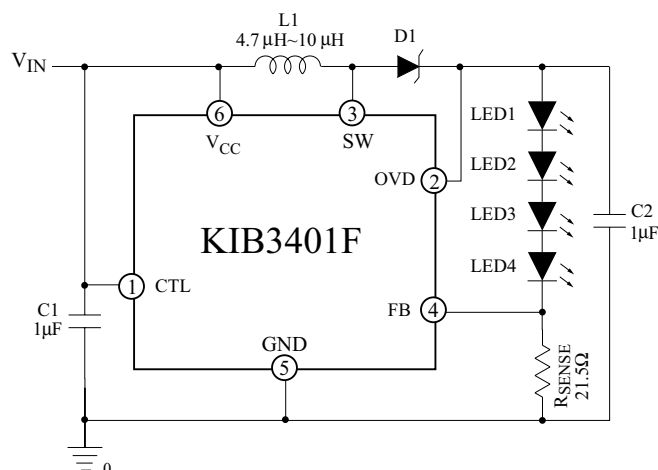

Figure4. 4LEDs driver with Open-circuit protection.

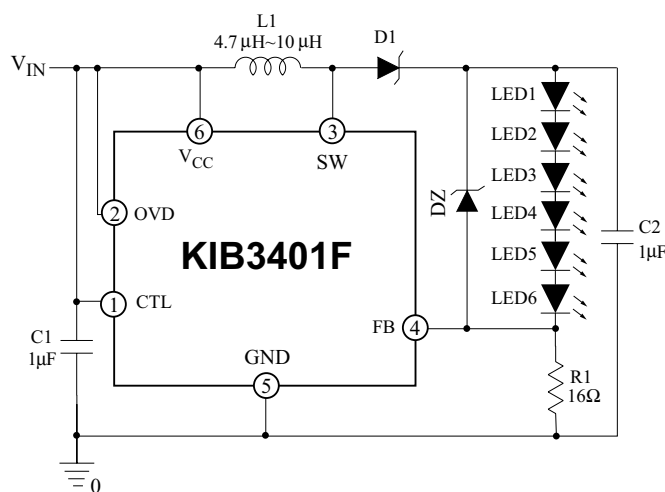

Figure5. 6LEDs driver with Open-circuit protection.

Dimming Control

There are 4 different type of dimming control circuits:

1. Using a DC Voltage to CTL pin.

Description	V _{CTL}			UNIT
	0V~0.5V	1V~2.5V	V _{CTL} >2.5V	
Rate Of the LED Current	0	25 ~ 100	100	%
Example : R _{SENSE} = 16 Ω	0	5 ~ 20	20	mA

Table 2 CTL pin Voltage vs I_{LED}

KIB3401F

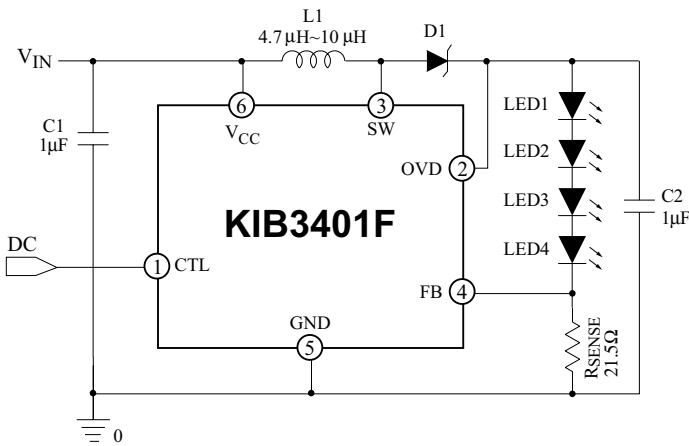

Figure6. Using a DC Signal to CTL pin.

2. Using a PWM Signal to CTL pin.

With the PWM signal applied to the CTL pin, the KIB3401F is turned on or off by the signal. Typical frequency range of the PWM signal is 15kHz to 30kHz. The switching waveforms of the CTL pin PWM control are shown in Figure 7(A) and 7(B)

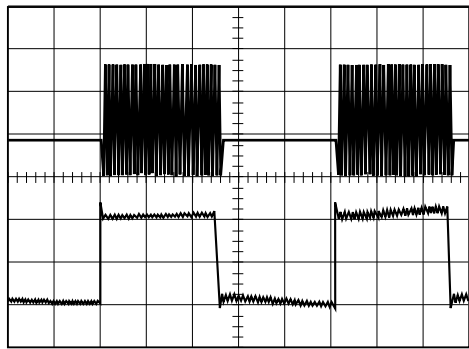

Figure 7. Using a PWM Signal to CTL pin.

3. Using a DC Voltage to FB pin.

The dimming control using a DC control voltage to FB pin of the KIB3401F is shown in Figure. The LED current can be varied applying a DC voltage to the FB pin. The voltage can come from a filtered PWM signal. It can be used to replace the variable DC Voltage source in dimming control.

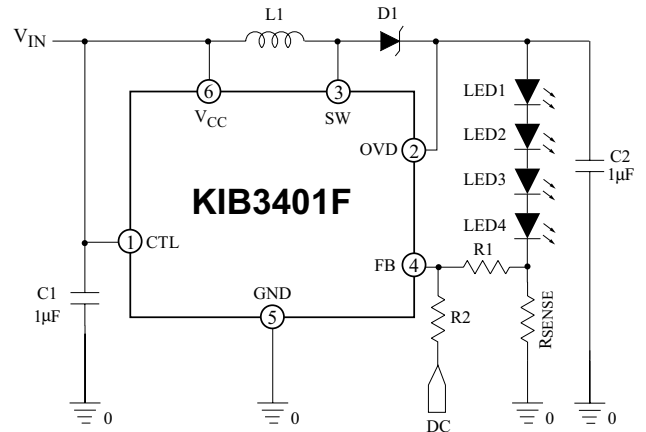
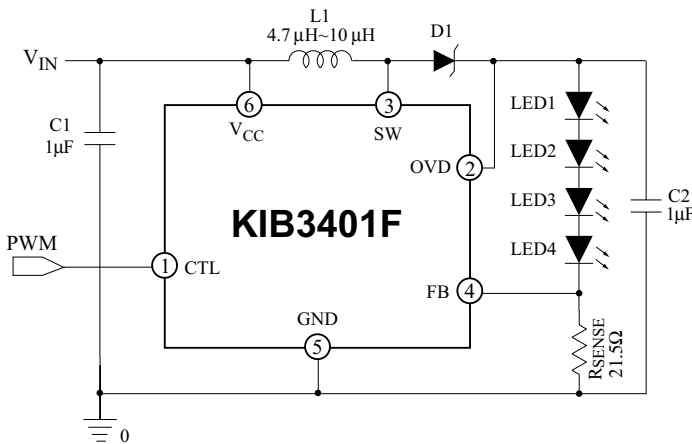
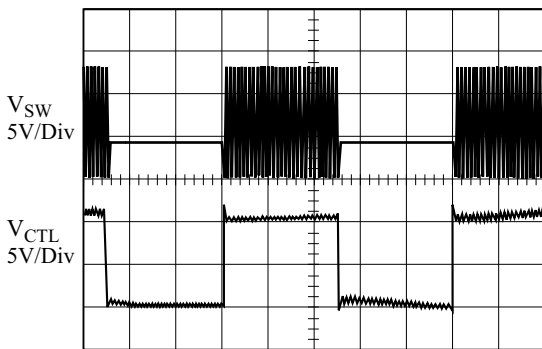

Figure8. Using DC Voltage to FB pin.

4. Using a Logic Signal to FB pin.

For applications that need to adjust the LED current in discret steps, a logic signal can be used as shown in Figure 9.



(A) 1kHz (2ms/Div)

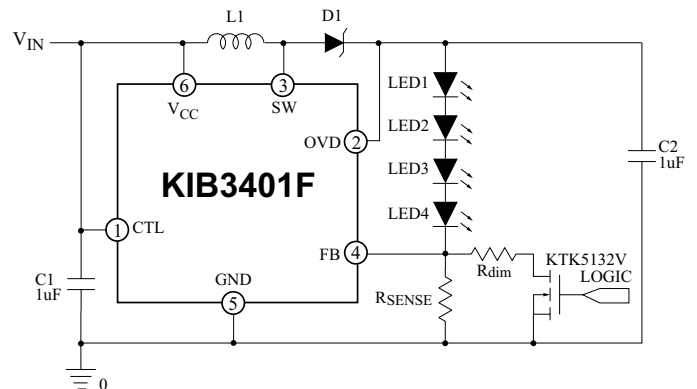
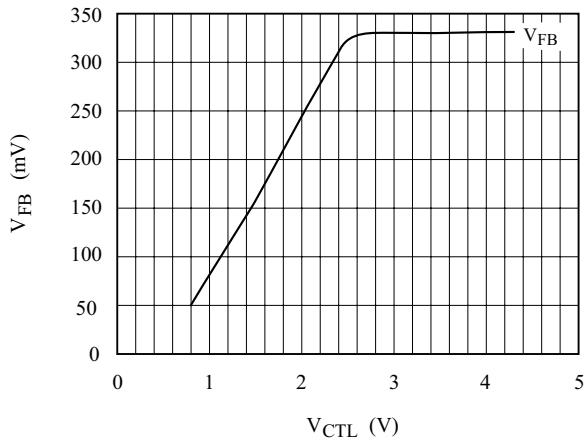

Figure9. Using a Logic Signal to FB pin.

KIB3401F

V_{FB} vs V_{CTL}



Efficiency vs Temperature

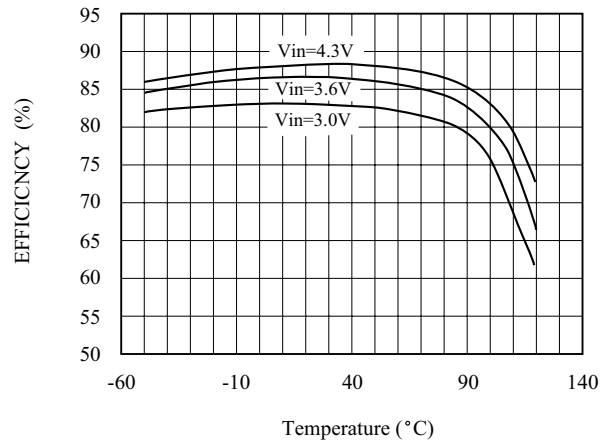

Frequency vs V_{CC}

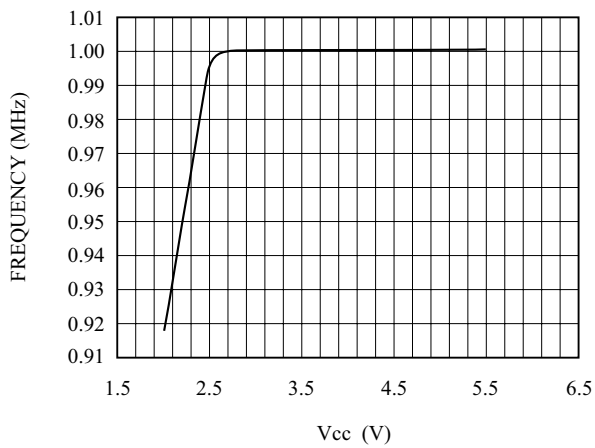

Switching Frequency vs Temperature

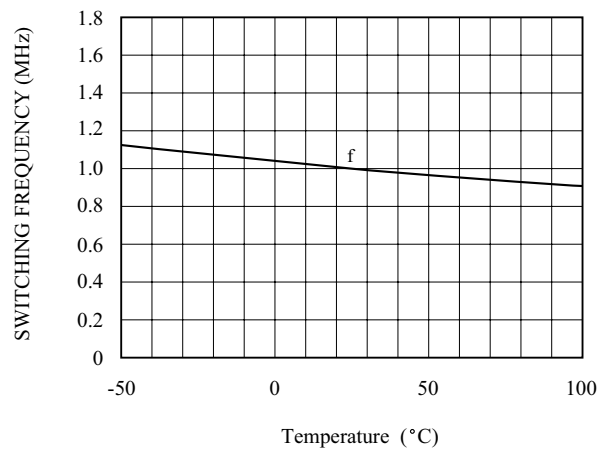

Quiescent Current vs Temperature

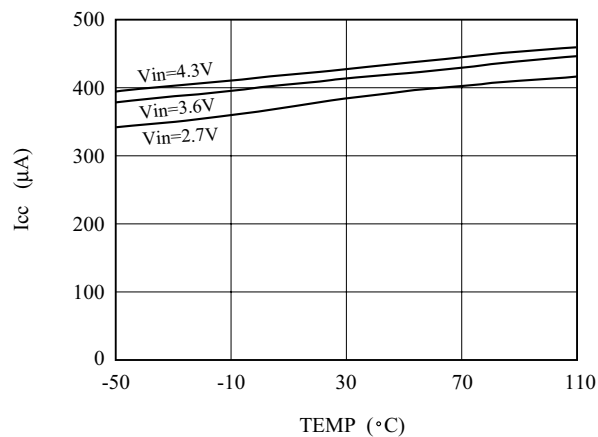

Thermal Shut Down

