

L513HDT BRIGHT RED	L513GDT GREEN
L513IDT HIGH EFFICIENCY RED	L513EDT ORANGE
L513SGDT SUPER BRIGHT GREEN	L513YDT YELLOW

### Features

- LOW POWER CONSUMPTION.
- RELIABLE AND RUGGED.
- EXCELLENT UNIFORMITY OF LIGHT OUTPUT.
- SUITABLE FOR LEVEL INDICATOR.
- I.C. COMPATIBLE.
- LONG LIFE - SOLID STATE RELIABILITY.

### Description

The Bright Red source color devices are made with Gallium Phosphide Red Light Emitting Diode.

The High Efficiency Red and Orange source color devices are made with Gallium Arsenide Phosphide on Gallium Phosphide Orange Light Emitting Diode.

The Green and Super Bright Green source color devices are made with Gallium Phosphide Green Light Emitting Diode.

The Yellow source color devices are made with Gallium Arsenide Phosphide on Gallium Phosphide Yellow Light Emitting Diode.

### Package Dimensions

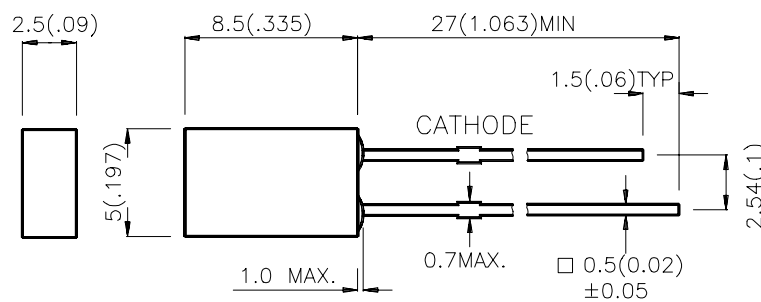

#### Notes:

1. All dimensions are in millimeters (inches).
2. Tolerance is  $\pm 0.25(0.01)$  unless otherwise noted.
3. Lead spacing is measured where the lead emerge package.
4. Specifications are subject to change without notice.

## Selection Guide

Part No.	Dice	Lens Type	Iv (mcd) @ 10 mA *20mA		Viewing Angle
			Min.	Typ.	2θ1/2
L513HDT	BRIGHT RED (GaP)	RED DIFFUSED	0.5	1	110°
L513IDT	HIGH EFFICIENCY RED (GaAsP/GaP)	RED DIFFUSED	3	5	110°
L513EDT	ORANGE (GaAsP/GaP)	ORANGE DIFFUSED	3	5	110°
L513GDT	GREEN (GaP)	GREEN DIFFUSED	2	3	110°
L513YDT	YELLOW (GaAsP/GaP)	YELLOW DIFFUSED	2	3	110°
L513SGDT	SUPER BRIGHT GREEN (GaP)	GREEN DIFFUSED	*8	*10	110°

**Notes:**

1. θ1/2 is the angle from optical centerline where the luminous intensity is 1/2 the optical centerline value.
2. \* Luminous intensity with asterisk is measured at 20mA.

## Electrical / Optical Characteristics at T<sub>A</sub>=25°C

Symbol	Parameter	Device	Typ.	Max.	Units	Test Conditions
λ <sub>peak</sub>	Peak Wavelength	Bright Red High Efficiency Red Orange Green Yellow Super Bright Green	700 627 627 565 590 565		nm	IF=20mA
λ <sub>D</sub>	Dominate Wavelength	Bright Red High Efficiency Red Orange Green Yellow Super Bright Green	660 625 625 568 588 568		nm	IF=20mA
Δλ <sub>1/2</sub>	Spectral Line Halfwidth	Bright Red High Efficiency Red Orange Green Yellow Super Bright Green	45 45 45 30 35 30		nm	IF=20mA
C	Capacitance	Bright Red High Efficiency Red Orange Green Yellow Super Bright Green	40 15 15 15 20 15		pF	VF=0V;f=1MHz
V <sub>F</sub>	Forward Voltage	Bright Red High Efficiency Red Orange Green Yellow Super Bright Green	2.25 2.0 2.0 2.2 2.1 2.2	2.5 2.5 2.5 2.5 2.5 2.5	V	IF=20mA
I <sub>R</sub>	Reverse Current	All		10	uA	VR = 5V

## Absolute Maximum Ratings at $T_A=25^\circ\text{C}$

Parameter	Bright Red	High Efficiency Red	Orange	Green	Yellow	Super Bright Green	Units
Power dissipation	120	105	105	105	105	105	mW
DC Forward Current	25	30	30	25	30	25	mA
Peak Forward Current [1]	120	160	160	140	140	140	mA
Reverse Voltage	5	5	5	5	5	5	V
Operating/Storage Temperature	-40°C To +85°C						
Lead Solder Temperature [2]	260°C For 5 Seconds						

Notes:

- 1/10 Duty Cycle, 0.1ms Pulse Width.
- 2.4mm below package base.

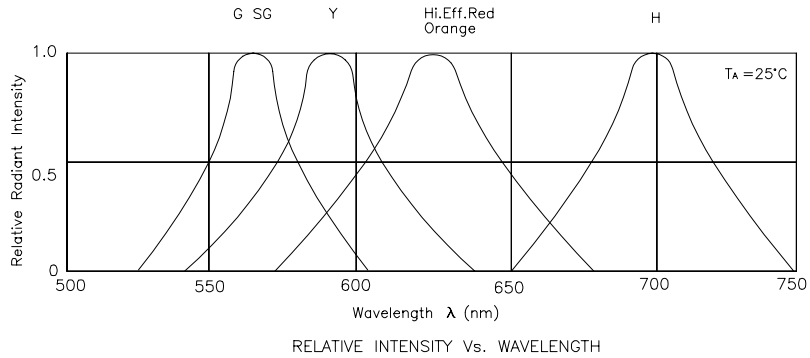

## Bright Red L513HDT

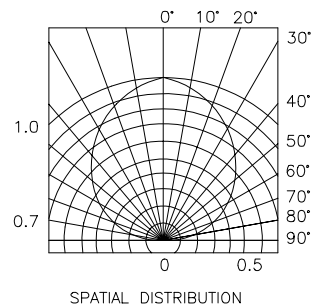
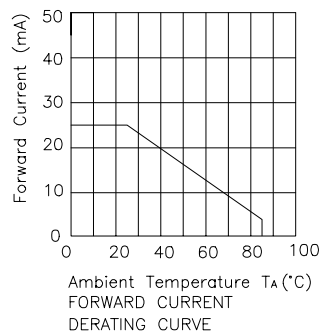
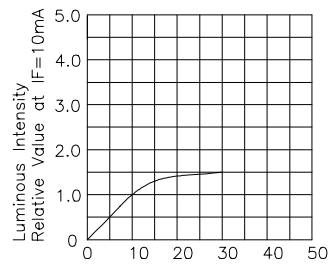
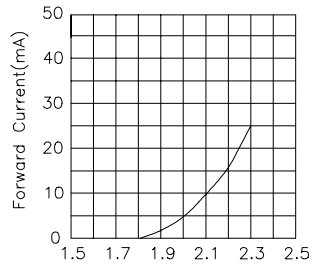

## High Efficiency Red L513IDT

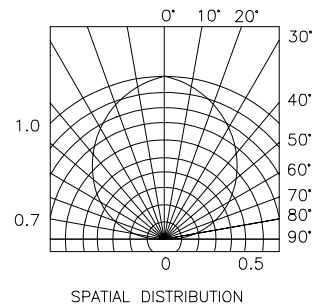
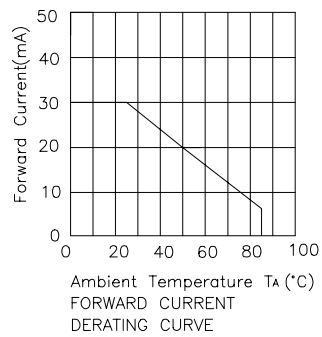
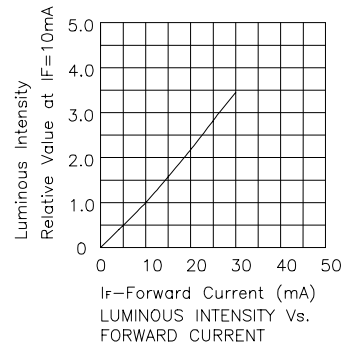
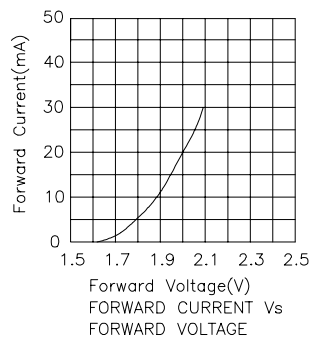

## Orange L513EDT

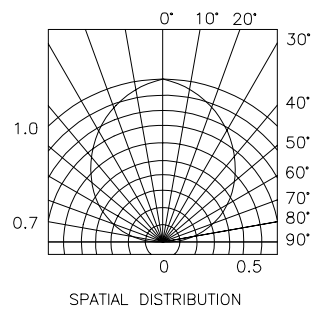
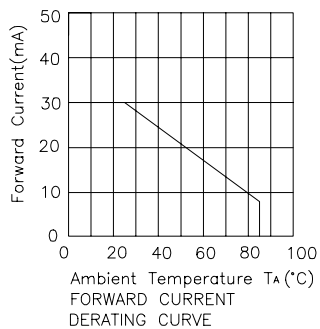
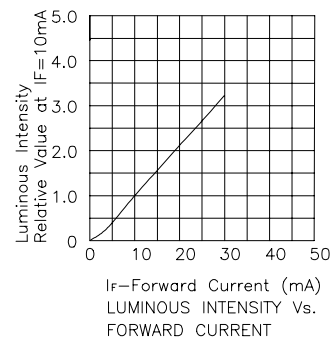
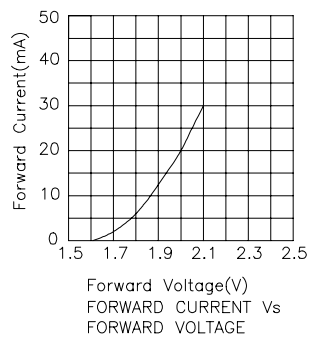

## Green L513GDT

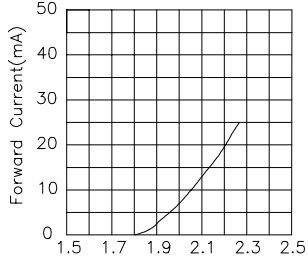

Forward Voltage(V)  
FORWARD CURRENT Vs  
FORWARD VOLTAGE

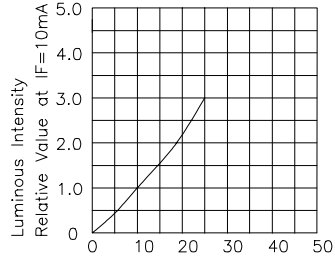

If-Forward Current (mA)  
LUMINOUS INTENSITY Vs.  
FORWARD CURRENT

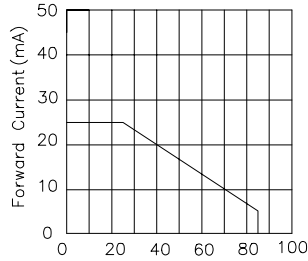

Ambient Temperature  $T_a$ (°C)  
FORWARD CURRENT  
DERATING CURVE

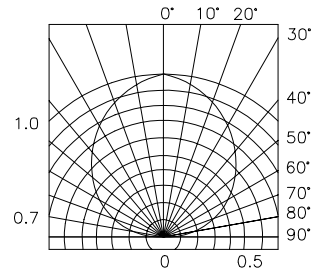

SPATIAL DISTRIBUTION

## Yellow L513YDT

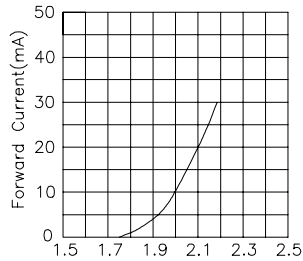

Forward Voltage(V)  
FORWARD CURRENT Vs.  
FORWARD VOLTAGE

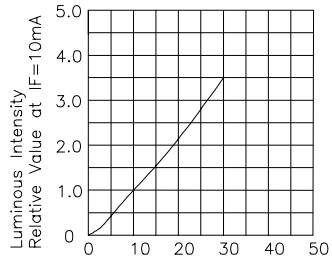

If-Forward Current (mA)  
LUMINOUS INTENSITY Vs.  
FORWARD CURRENT

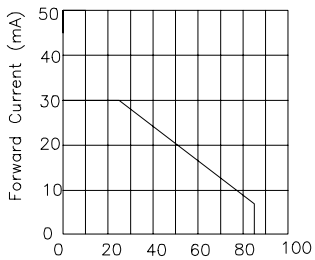

Ambient Temperature  $T_a$ (°C)  
FORWARD CURRENT  
DERATING CURVE

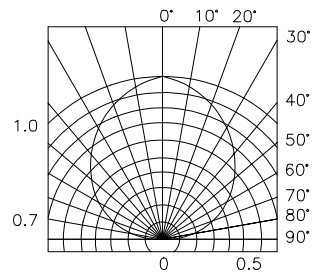

SPATIAL DISTRIBUTION

## Super Bright Green L513SGDT

