

L53BT12.7/SERIES  
 L53BT22.86/SERIES  
 L53BT25.4/SERIES

### Features

- LED FIRMLY HELD BY SPACER - NO ADDITIONAL FIXTURING OR GLUEING NECESSARY.
- CHOICE OF 3 HEIGHTS FOR MOUNTING LED ABOVE P.C. BOARD.
- CATHODE IS CLEARLY IDENTIFIED ON PACKAGE.
- SUITABLE FOR BACK PANEL ILLUMINATION, CIRCUIT BOARD INDICATOR, LED INDICATOR.
- UL RATING : 94V-0.
- HOUSING MATERIAL: TYPE 66 NYLON.

### Description

The High Efficiency Red and Orange source color devices are made with Gallium Arsenide Phosphide on Gallium Phosphide Orange Light Emitting Diode.

The Green and Super Bright Green source color devices are made with Gallium Phosphide Green Light Emitting Diode.

The Yellow source color devices are made with Gallium Arsenide Phosphide on Gallium Phosphide Yellow Light Emitting Diode.

The Super Bright Red source color devices are made with Gallium Aluminum Arsenide Red Light Emitting Diode.

### Package Dimensions

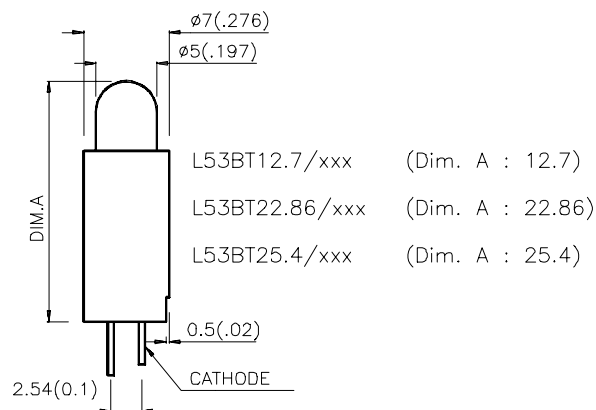

#### Notes:

1. All dimensions are in millimeters (inches).
2. Tolerance is  $\pm 0.25(0.01)$  unless otherwise noted.
3. Lead spacing is measured where the lead emerge package.
4. Specifications are subject to change without notice.

## Selection Guide

Part No.	Dice	Lens Type	Iv (mcd) @ 10 mA *20mA		Viewing Angle
			Min.	Typ.	2θ1/2
L53BT12.7/ID L53BT22.86/ID L53BT25.4/ID	HIGH EFFICIENCY RED (GaAsP/GaP)	RED DIFFUSED	8	30	60°
L53BT12.7/GD L53BT22.86/GD L53BT25.4/GD	GREEN (GaP)	GREEN DIFFUSED	5	20	60°
L53BT12.7/YD L53BT22.86/YD L53BT25.4/YD	YELLOW (GaAsP/GaP)	YELLOW DIFFUSED	5	20	60°
L53BT12.7/SGD L53BT22.86/SGD L53BT25.4/SGD	SUPER BRIGHT GREEN (GaP)	GREEN DIFFUSED	*20	*40	60°
L53BT12.7/SRD L53BT22.86/SRD L53BT25.4/SRD	SUPER BRIGHT RED (GaAlAs)	RED DIFFUSED	*100	*300	60°

Notes:

1. θ1/2 is the angle from optical centerline where the luminous intensity is 1/2 the optical centerline value.
2. \* Luminous intensity with asterisk is measured at 20mA.

## Electrical / Optical Characteristics at T<sub>A</sub>=25°C

Symbol	Parameter	Device	Typ.	Max.	Units	Test Conditions
λ <sub>peak</sub>	Peak Wavelength	High Efficiency Red Green Yellow Super Bright Red Super Bright Green	627 565 590 660 565		nm	IF=20mA
λ <sub>D</sub>	Dominate Wavelength	High Efficiency Red Green Yellow Super Bright Red Super Bright Green	625 568 588 640 568		nm	IF=20mA
Δλ <sub>1/2</sub>	Spectral Line Halfwidth	High Efficiency Red Green Yellow Super Bright Red Super Bright Green	45 30 35 20 30		nm	IF=20mA
C	Capacitance	High Efficiency Red Green Yellow Super Bright Red Super Bright Green	15 15 20 45 15		pF	VF=0V;f=1MHz
V <sub>F</sub>	Forward Voltage	High Efficiency Red Green Yellow Super Bright Red Super Bright Green	2.0 2.2 2.1 1.85 2.2	2.5 2.5 2.5 2.5 2.5	V	IF=20mA
I <sub>R</sub>	Reverse Current	All		10	uA	VR = 5V

## Absolute Maximum Ratings at $T_A=25^\circ\text{C}$

Parameter	High Efficiency Red	Green	Yellow	Super Bright Red	Super Bright Green	Units
Power dissipation	105	105	105	100	105	mW
DC Forward Current	30	25	30	30	25	mA
Peak Forward Current [1]	160	140	140	155	140	mA
Reverse Voltage	5	5	5	5	5	V
Operation/Storage Temperature	-40°C To +85°C					
Lead Solder Temperature [2]	260°C For 5 Seconds					

**Notes:**

- 1/10 Duty Cycle, 0.1ms Pulse Width.
- 4mm below package base.

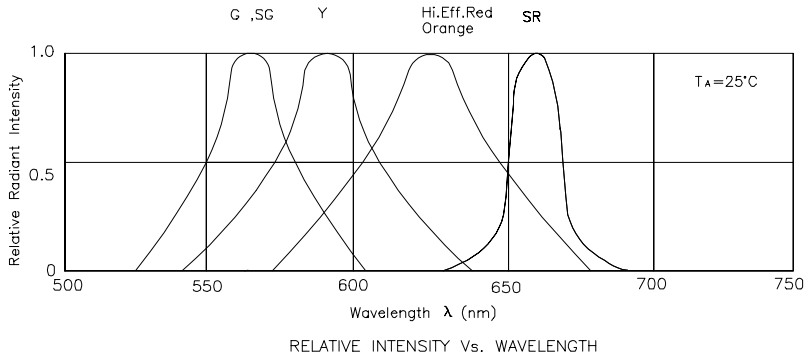

## High Efficiency Red

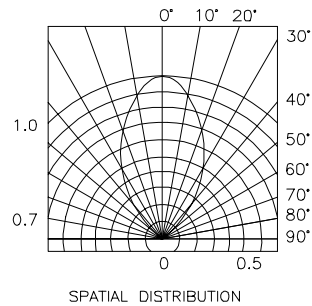
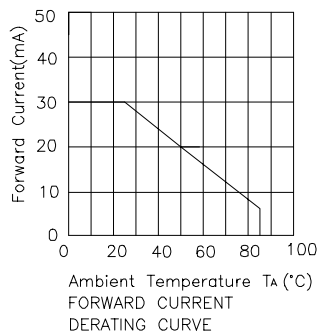
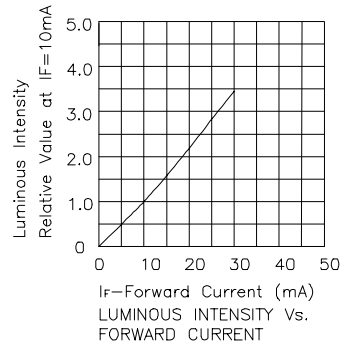
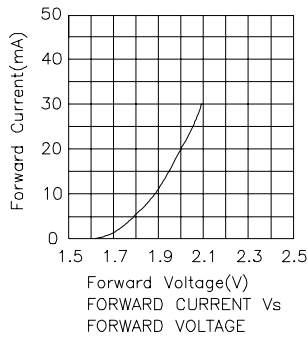

# Kingbright

## Green

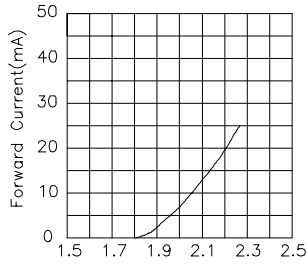

Forward Voltage(V)  
FORWARD CURRENT Vs  
FORWARD VOLTAGE

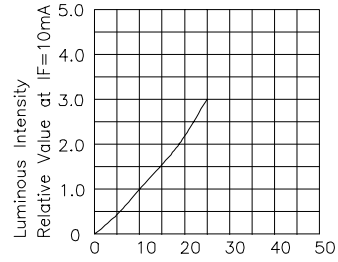

IF-Forward Current (mA)  
LUMINOUS INTENSITY Vs.  
FORWARD CURRENT

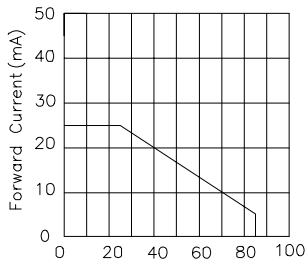

Ambient Temperature TA(°C)  
FORWARD CURRENT  
DERATING CURVE

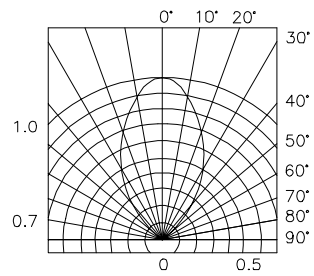

SPATIAL DISTRIBUTION

## Yellow

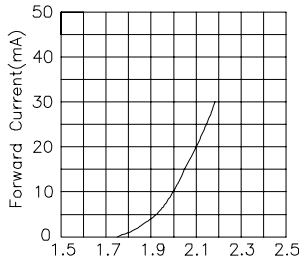

Forward Voltage(V)  
FORWARD CURRENT Vs.  
FORWARD VOLTAGE

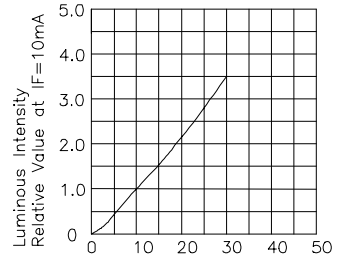

IF-Forward Current (mA)  
LUMINOUS INTENSITY Vs.  
FORWARD CURRENT

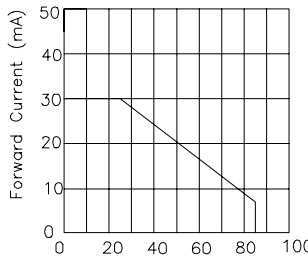

Ambient Temperature TA(°C)  
FORWARD CURRENT  
DERATING CURVE

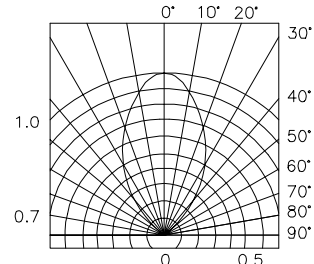

SPATIAL DISTRIBUTION

# Kingbright

## Super Bright Red

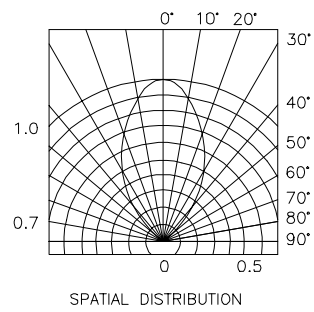
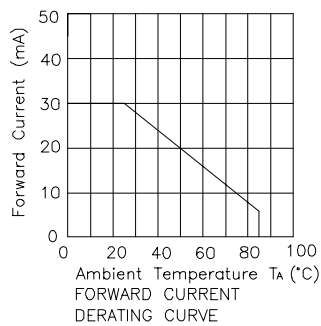
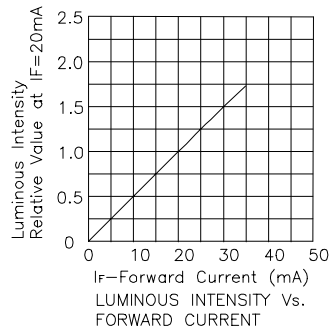
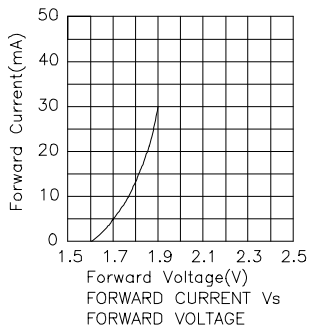

## Super Bright Green

