

L813SRC/x SUPER BRIGHT RED

L813SRD/x SUPER BRIGHT RED

Features

- ULTRA BRIGHTNESS.
- 10mm DIAMETER BIG LAMP.
- WIDE VIEWING ANGLE.
- I.C. COMPATIBLE.
- BOTH DIFFUSED AND WATER CLEAR LENS ARE AVAILABLE.
- RELIABLE AND RUGGED.
- LONG LIFE - SOLID STATE RELIABILITY.

Description

The Super Bright Red source color devices are made with Gallium Aluminum Arsenide Red Light Emitting Diode.

Package Dimensions

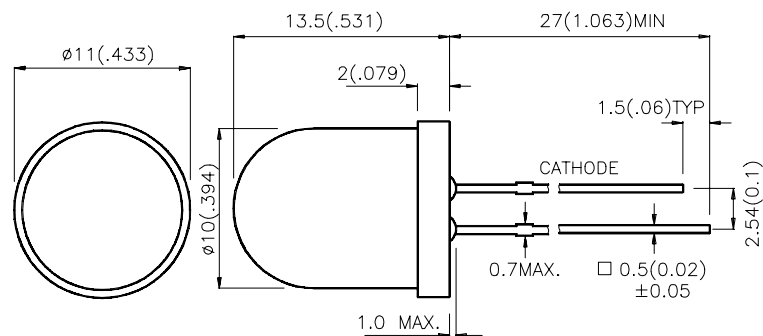

Notes:

1. All dimensions are in millimeters (inches).
2. Tolerance is $\pm 0.25(0.01)$ unless otherwise noted.
3. Lead spacing is measured where the lead emerge package.
4. Specifications are subject to change without notice.

Selection Guide

Part No.	Dice	Lens Type	I _v (mcd) @ 20 mA		Viewing Angle
			Min.	Typ.	θ _{1/2}
L813SRC/C	SUPER BRIGHT RED (GaAlAs)	WATER CLEAR	1000	1500	40°
L813SRC/D			1600	1800	40°
L813SRC/E			2000	2800	40°
L813SRC/F			3000	3800	40°
L813SRD/C	SUPER BRIGHT RED (GaAlAs)	RED DIFFUSED	200	300	60°
L813SRD/D			350	400	60°
L813SRD/E			450	500	60°
L813SRD/F			550	600	60°
L813SRD/G			650	700	60°
L813SRD/H			800	1200	60°

Note:

1. θ_{1/2} is the angle from optical centerline where the luminous intensity is 1/2 the optical centerline value.

Electrical / Optical Characteristics at T_A=25°C

Symbol	Parameter	Device	Typ.	Max.	Units	Test Conditions
λ _{peak}	Peak Wavelength	Super Bright Red	660		nm	IF=20mA
λ _D	Dominate Wavelength	Super Bright Red	640		nm	IF=20mA
Δλ _{1/2}	Spectral Line Halfwidth	Super Bright Red	20		nm	IF=20mA
C	Capacitance	Super Bright Red	45		pF	VF=0V;f=1MHz
V _F	Forward Voltage	Super Bright Red	1.85	2.5	V	IF=20mA
I _R	Reverse Current	Super Bright Red		10	uA	VR = 5V

Absolute Maximum Ratings at T_A=25°C

Parameter	Super Bright Red	Units
Power dissipation	100	mW
DC Forward Current	30	mA
Peak Forward Current [1]	155	mA
Reverse Voltage	5	V
Operating/Storage Temperature	-40°C To +85°C	
Lead Solder Temperature [2]	260°C For 5 Seconds	

Notes:

1. 1/10 Duty Cycle, 0.1ms Pulse Width.
2. 4mm below package base.

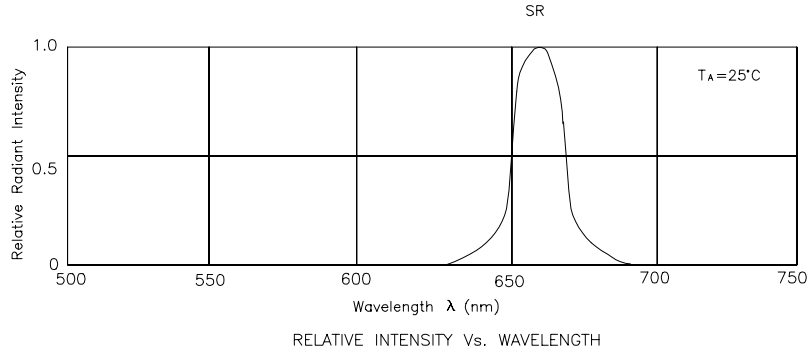

Super Bright Red L813SRC/x, L813SRD/x

