

White LED Driver with Integrated Schottky in 3mm × 2mm DFN

FEATURES

- Drives Up to Ten White LEDs from a 3V Supply
- High Side Sense Allows “One Wire Current Source”
- Internal Schottky Diode
- One Pin Dimming and Shutdown
- 80:1 True Color PWM™ Dimming Range
- 42V Open LED Protection
- 1MHz Switching Frequency
- ±5% Reference Accuracy
- V_{IN} Range: 2.5V to 12V
- Requires Only 2.2 μ F Output Capacitor
- Low Profile 8-Lead DFN Package (3mm × 2mm × 0.75mm)

APPLICATIONS

- Cellular Phones
- PDAs, Handheld Computers
- Digital Cameras
- MP3 Players
- GPS Receivers

DESCRIPTION

The LT[®]3591 is a fixed frequency step-up DC/DC converter specifically designed to drive up to ten white LEDs in series from a Li-Ion cell. Series connection of the LEDs provides identical LED currents resulting in uniform brightness and eliminating the need for ballast resistors. The device features a unique high side LED current sense that enables the part to function as a “one wire current source;” one side of the LED string can be returned to ground anywhere, allowing a simpler one wire LED connection. Traditional LED drivers use a grounded resistor to sense LED current, requiring a 2-wire connection to the LED string.

The high switching frequency allows the use of tiny inductors and capacitors. A single pin performs both shutdown and accurate LED dimming control. Few external components are needed: open-LED protection and the Schottky diode are all contained inside a low profile 3mm × 2mm DFN package.

LT, LT, LTC and LTM are registered trademarks of Linear Technology Corporation. True Color PWM is a trademark of Linear Technology Corporation. All other trademarks are the property of their respective owners.

TYPICAL APPLICATION

Li-Ion Driver for Ten White LEDs

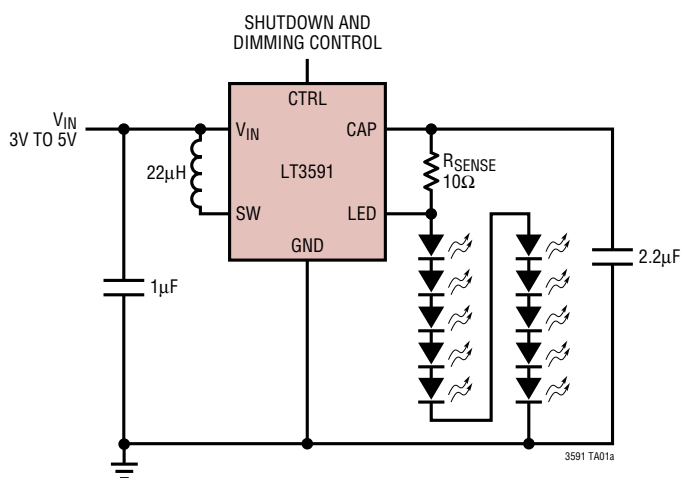

Conversion Efficiency

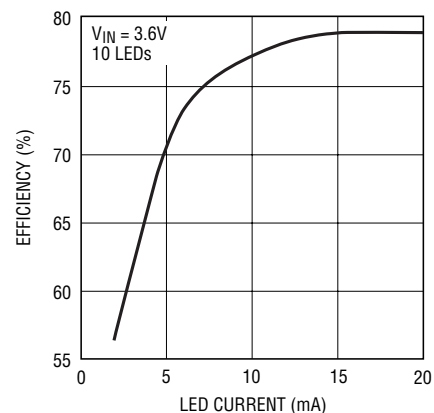

3591 TA01b

ABSOLUTE MAXIMUM RATINGS

(Note 1)

Input Voltage (V_{IN})	12V
CTRL Voltage	12V
SW Voltage	45V
CAP Voltage	45V
LED Voltage	45V

Operating Junction Temperature Range

(Note 2) -40°C to 85°C

Maximum Junction Temperature 125°C

Storage Temperature Range -65°C to 150°C

PACKAGE/ORDER INFORMATION

TOP VIEW

DDB PACKAGE
8-LEAD (3mm × 2mm) PLASTIC DFN
 $T_{JMAX} = 125^{\circ}\text{C}$, $\theta_{JA} = 76^{\circ}\text{C/W}$
EXPOSED PAD (PIN 9) SHOULD BE CONNECTED TO PCB GROUND

ORDER PART NUMBER	DDB PART MARKING
LT3591EDDB	LCPG

Order Options Tape and Reel: Add #TR
Lead Free: Add #PBF Lead Free Tape and Reel: Add #TRPBF
Lead Free Part Marking: <http://www.linear.com/leadfree/>

Consult LTC Marketing for parts specified with wider operating temperature ranges.

ELECTRICAL CHARACTERISTICS

The ● denotes the specifications which apply over the full operating temperature range, otherwise specifications are at $T_A = 25^{\circ}\text{C}$. $V_{IN} = 3\text{V}$, $V_{CTRL} = 3\text{V}$, unless otherwise specified.

PARAMETER	CONDITIONS	MIN	TYP	MAX	UNITS
Minimum Operating Voltage		2.5			V
LED Current Sense Voltage ($V_{CAP} - V_{LED}$)	$V_{CAP} = 24\text{V}$, $I_{SW} = 300\text{mA}$	● 190	200	210	mV
CAP Pin Bias Current	$V_{CAP} = 36\text{V}$, $V_{LED} = 35.8\text{V}$		40	80	μA
LED Pin Bias Current	$V_{CAP} = 36\text{V}$, $V_{LED} = 35.8\text{V}$		20	40	μA
Supply Current	$V_{CAP} = 24\text{V}$, $V_{LED} = 23\text{V}$ $CTRL = 0\text{V}$		4 9	5 11	mA μA
Switching Frequency		0.75	1	1.2	MHz
Maximum Duty Cycle		92	94		%
Switch Current Limit		● 500	800		mA
Switch V_{CESAT}	$I_{SW} = 300\text{mA}$		200		mV
Switch Leakage Current	$V_{SW} = 24\text{V}$		0.1	5	μA
V_{CTRL} for Full LED Current	$V_{CAP} = 44\text{V}$	● 1.5			V
V_{CTRL} to Shut Down IC				50	mV
V_{CTRL} to Turn On IC		● 100			mV
CTRL Pin Bias Current			100		nA
CAP Pin Overvoltage Protection		● 40	42	44	V
Schottky Forward Drop	$I_{SCHOTTKY} = 200\text{mA}$		0.8		V
Schottky Leakage Current	$V_R = 30\text{V}$			4	μA

Note 1: Stresses beyond those listed under Absolute Maximum Ratings may cause permanent damage to the device. Exposure to any Absolute Maximum Rating condition for extended periods may affect device reliability and lifetime.

Note 2: The LT3591E is guaranteed to meet performance specifications from 0°C to 85°C operating junction temperature range. Specifications over the -40°C to 85°C operating junction temperature range are assured by design, characterization and correlation with statistical process controls.

TYPICAL PERFORMANCE CHARACTERISTICS $T_A = 25^\circ\text{C}$, unless otherwise specified.

Switch Saturation Voltage (V_{CESAT})

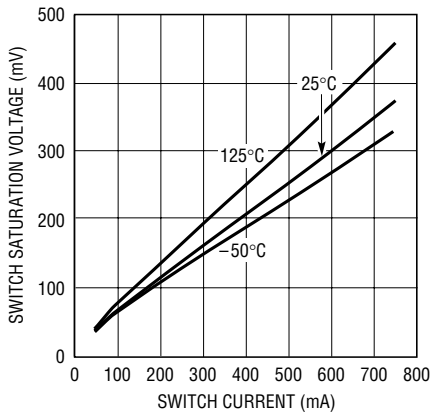

3591 G01

Schottky Forward Voltage Drop

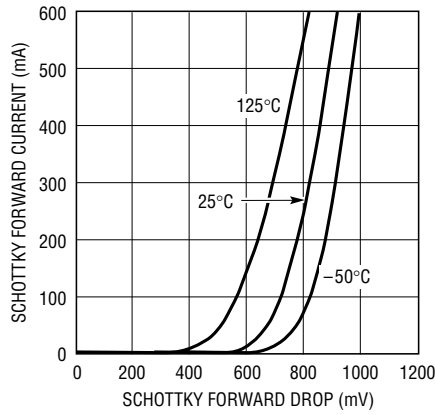

3591 G02

Shutdown Current ($V_{CTRL} = 0\text{V}$)

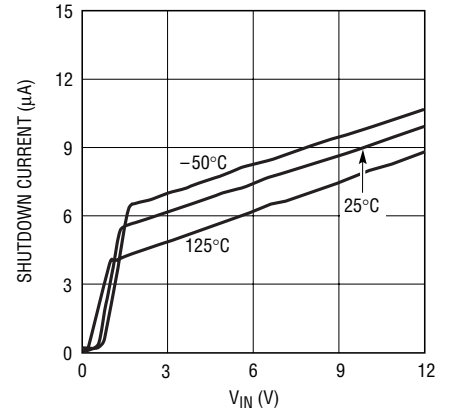

3591 G03

Sense Voltage ($V_{CAP} - V_{LED}$) vs V_{CTRL}

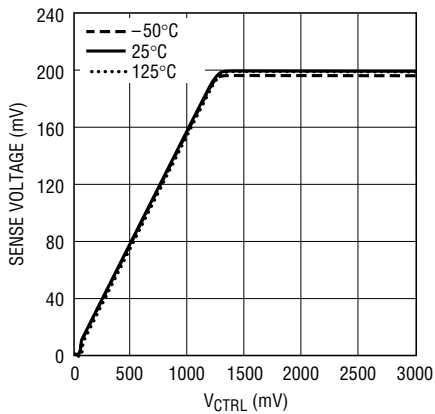

3591 G04

Open-Circuit Output Clamp Voltage

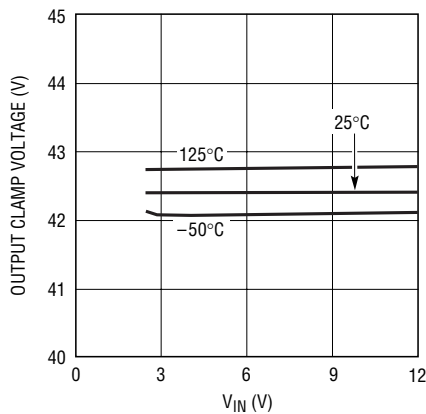

3591 G05

Input Current in Output Open Circuit

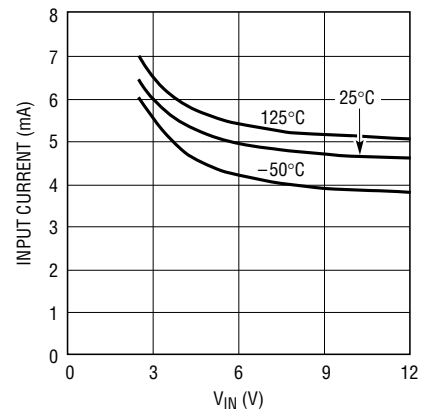

3591 G06

Switching Waveform

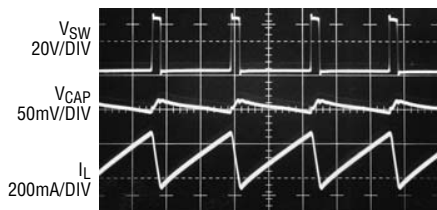

$V_{IN} = 3.6\text{V}$
FRONT PAGE
APPLICATION CIRCUIT

3591 G07

Transient Response

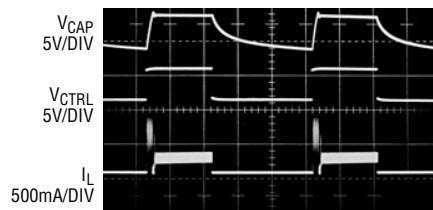

$V_{IN} = 3.6\text{V}$
FRONT PAGE
APPLICATION CIRCUIT

3591 G08

TYPICAL PERFORMANCE CHARACTERISTICS $T_A = 25^\circ\text{C}$, unless otherwise specified.

Quiescent Current
($V_{CTRL} = 3\text{V}$)

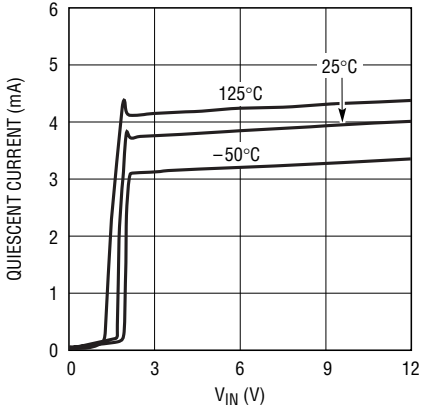

Current Limit vs Temperature

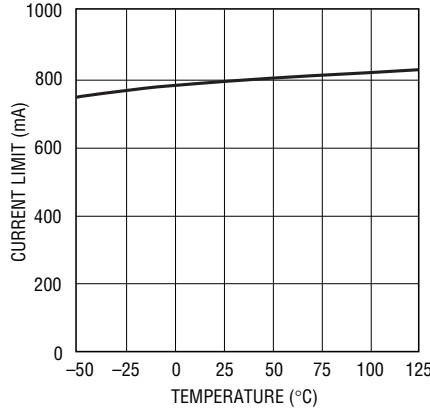

Schottky Leakage Current vs Temperature

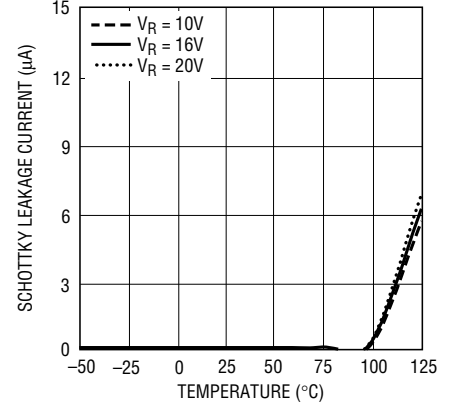

Open-Circuit Output Clamp Voltage vs Temperature

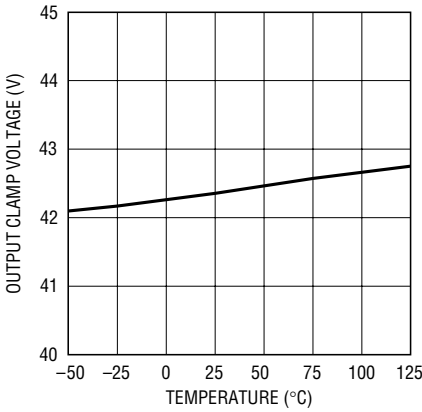

Input Current in Output Open Circuit vs Temperature

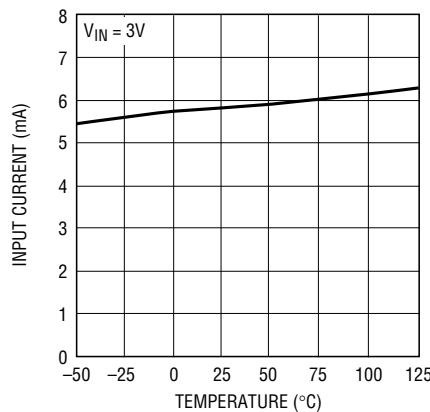

Switching Frequency vs Temperature

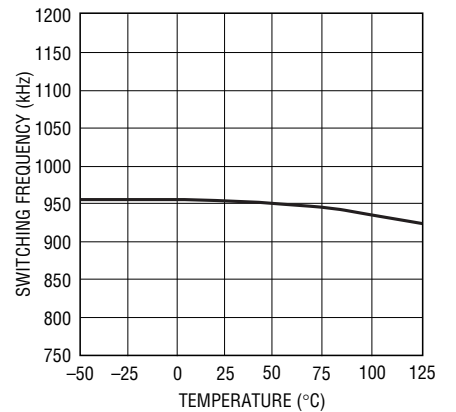

Maximum Duty Cycle vs Temperature

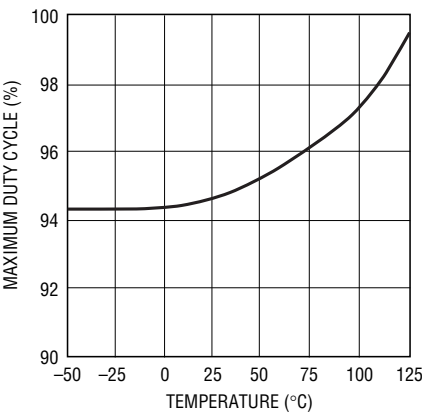

Sense Voltage ($V_{CAP} - V_{LED}$) vs V_{CAP}

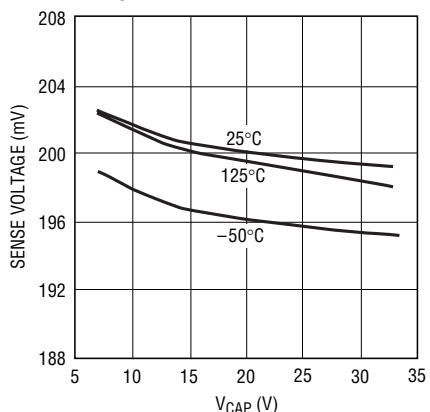

Sense Voltage ($V_{CAP} - V_{LED}$) vs Temperature

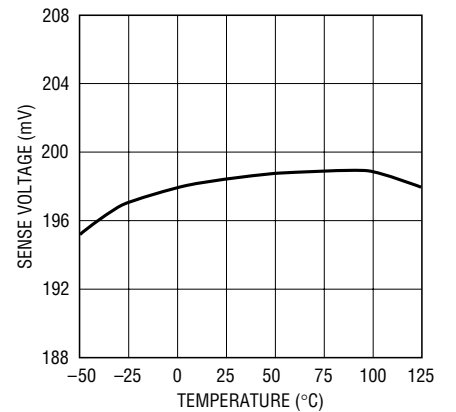

PIN FUNCTIONS

V_{IN} (Pin 1): Input Supply Pin. Must be locally bypassed.

GND (Pin 2): Ground Pin. Should be tied directly to local ground plane.

SW (Pin 4): Switch Pin. Minimize trace area at this pin to minimize EMI. Connect the inductor at this pin.

CAP (Pin 5): Output of the Driver. This pin is connected to the cathode of internal Schottky. Connect the output capacitor to this pin and the sense resistor from this pin to the LED pin.

LED (Pin 7): Connection Point for the Anode of the First LED and the Sense Resistor. The LED current can be programmed by :

$$I_{LED} = \frac{200mV}{R_{SENSE}}$$

CTRL (Pin 8): Dimming and Shutdown Pin. Connect this pin below 50mV to disable the driver. As the pin voltage is ramped from 0V to 1.5V, the LED current ramps from 0 to I_{LED} ($= 200mV/R_{SENSE}$). The CTRL pin must not be left floating.

Exposed Pad (Pin 9): Ground. The Exposed Pad must be soldered to PCB ground to achieve the rated thermal performance.

BLOCK DIAGRAM

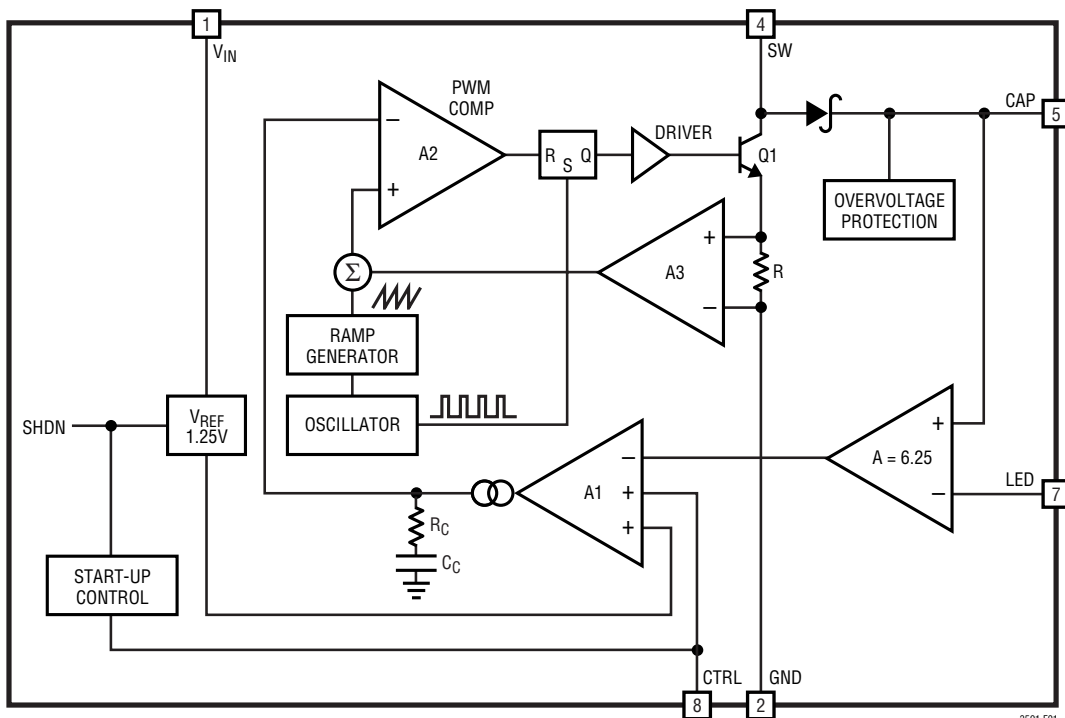

Figure 1. Block Diagram

OPERATION

The LT3591 uses a constant frequency, current mode control scheme to provide excellent line and load regulation. Operation can be best understood by referring to the Block Diagram in Figure 1.

At power-up, the capacitor at the CAP pin is charged up to V_{IN} (input supply voltage) through the inductor and the internal Schottky diode. If CTRL is pulled higher than 100mV, the bandgap reference, the start-up bias and the oscillator are turned on. At the start of each oscillator cycle, the power switch Q1 is turned on. A voltage proportional to the switch current is added to a stabilizing ramp and the resulting sum is fed into the positive terminal of the PWM comparator, A2. When this voltage exceeds the level at the negative input of A2, the PWM logic turns off the power switch. The level at the negative input of A2 is set by the error amplifier A1, and is simply an amplified version of the difference between the V_{CAP} and V_{LED} voltage and the bandgap reference. In this manner the error amplifier, A1, sets the correct peak current level in inductor L1 to keep the output in regulation. The CTRL pin is used to adjust

the LED current. The LT3591 enters into shutdown when CTRL is pulled lower than 50mV.

Minimum Output Current

The LT3591 can drive a 2-LED string at 2mA LED current without pulse skipping using the same external components shown in the application circuit on the front page of this data sheet. As current is further reduced, the device will begin skipping pulses. This will result in some low frequency ripple, although the average LED current remains regulated down to zero. The photo in Figure 2 details circuit operation driving two white LEDs at 2mA load. Peak inductor current is less than 40mA and the regulator operates in discontinuous mode, meaning the inductor current reaches zero during the discharge phase. After the inductor current reaches zero, the SW pin exhibits ringing due to the LC tank circuit formed by the inductor in combination with the switch and the diode capacitance. This ringing is not harmful; far less spectral energy is contained in the ringing than in the switch transitions.

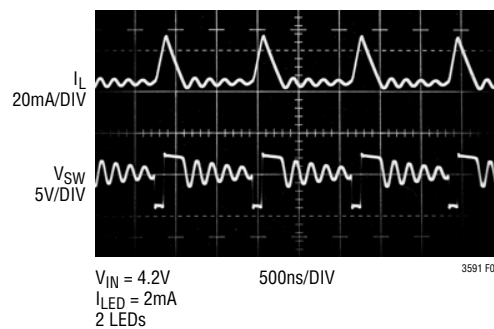

Figure 2. Switching Waveforms

APPLICATIONS INFORMATION

INDUCTOR SELECTION

A 22 μ H inductor is recommended for most LT3591 applications. Although small size and high efficiency are major concerns, the inductor should have low core losses at 1MHz and low DCR (copper wire resistance). Some small inductors in this category are listed in Table 1. The efficiency comparison of different inductors is shown in Figure 3.

Table 1. Recommended Inductors

PART	L (μ H)	CURRENT RATING (mA)	MAX DIMENSION L x W x H (mm)	VENDOR
VLF4012AT-220MR51	22	510	4 x 3.8 x 1.2	TDK www.tdk.com
VLCF4018T-220MR49-2	22	490	4.1 x 4.1 x 1.8	
VLCF4020T-220MR56	22	560	4.1 x 4.1 x 2	
LQH43CN220K03	22	420	4.8 x 3.4 x 2.8	Murata www.murata.com
NR4018T220M	22	590	4.2 x 4.2 x 1.8	Taiyo Yuden www.t-yuden.com
NR4012T220M	22	510	4.2 x 4.2 x 1.2	
CDRH3D18-220NC	22	600	4 x 4 x 2	Sumida www.sumida.com
B82470-A1223-M	22	480	4.8 x 4.8 x 1.2	Epcos www.epcos.com

CAPACITOR SELECTION

The small size of ceramic capacitors make them ideal for LT3591 applications. Use only X5R and X7R types because they retain their capacitance over wider temperature ranges than other types such as Y5V or Z5U. A 1 μ F input capacitor and a 50V, 2.2 μ F output capacitor are sufficient for most applications.

A limited number of manufacturers produce small 50V capacitors. Table 2 shows a list of several recommended 50V capacitors. Consult the manufacturer for detailed information on their entire selection of ceramic parts.

Table 2. Recommended Output Capacitors

PART	C (μ F)	VOLTAGE	CASE SIZE	VENDOR
		TEMP.	HEIGHT (mm)	
GRM21BR71H105KA12L	1	50V	0805	Murata www.murata.com
		X7R	1.25 \pm 0.15	
GRM31MR71H105KA88	1	50V	1206	Murata www.murata.com
		X7R	1.15 \pm 0.1	
GRM31CR71H225KA88	2.2	50V	1206	Murata www.murata.com
		X7R	1.6 \pm 0.2	
GRM31CR71H475KA12L	4.7	50V	1206	Murata www.murata.com
		X7R	1.6 \pm 0.2	
UMK316BJ475KL-T	4.7	50V	1206	Taiyo Yuden www.t-yuden.com
		X7R	1.6 \pm 0.2	

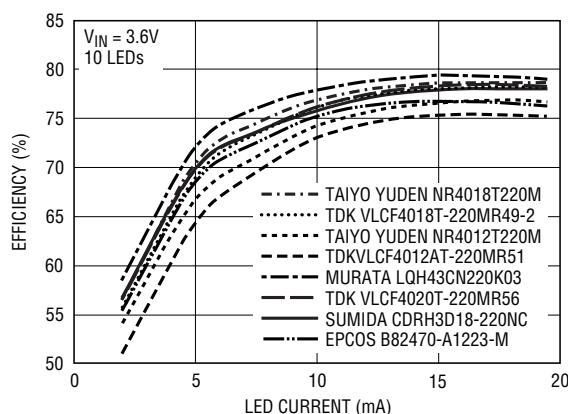

Figure 3. Efficiency Comparison of Different Inductors

3591 F03

APPLICATIONS INFORMATION

SCHOTTKY DIODE

The LT3591 has a built-in Schottky diode. The internal schottky saves board space in space constrained applications. In less space sensitive applications, an external schottky diode connected between the SW node and the CAP node increases efficiency one to two percent. It is important to use a properly rated schottky diode that can handle the peak switch current of the LT3591. In addition, the schottky diode must have a breakdown voltage of at least 40V along with a low forward voltage in order to achieve higher efficiency. One recommended external schottky diode for the LT3591 is the Phillips PMEG4005AEA.

OVERVOLTAGE PROTECTION

The LT3591 has an internal open-circuit protection circuit. In the cases of output open circuit, when the LEDs are disconnected from the circuit or the LEDs fail open circuit, V_{CAP} is clamped at 42V (typ). The LT3591 will then switch at a very low frequency to minimize input current. The V_{CAP} and input current during output open circuit are shown in the Typical Performance Characteristics. Figure 4 shows the transient response when the LEDs are disconnected.

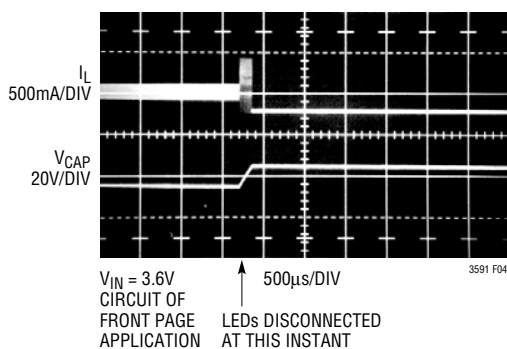

Figure 4. Output Open-Circuit Waveform

INRUSH CURRENT

The LT3591 has a built-in Schottky diode. When supply voltage is applied to the V_{IN} pin, an inrush current flows through the inductor and the Schottky diode and charges up the CAP voltage. The Schottky diode inside the LT3591 can sustain a maximum current of 1A.

For low DCR inductors, which is usually the case for this application, the peak inrush current can be simplified as follows:

$$I_{PK} = \frac{V_{IN} - 0.6}{L \cdot \omega} \cdot \exp\left(-\frac{\alpha}{\omega} \cdot \frac{\pi}{2}\right)$$

$$\alpha = \frac{r}{2 \cdot L}$$

$$\omega = \sqrt{\frac{1}{L \cdot C} - \frac{r^2}{4 \cdot L^2}}$$

where L is the inductance, r is the DCR of the inductor and C is the output capacitance.

Table 3 gives inrush peak currents for some component selections.

Table 3. Inrush Peak Currents

V_{IN} (V)	r (Ω)	L (μ H)	C_{OUT} (μ F)	I_P (A)
4.2	0.3	22	2.2	1.06
4.2	0.71	22	2.2	0.96
4.2	0.58	15	1	0.83
4.2	1.6	15	1	0.68

PROGRAMMING LED CURRENT

The feedback resistor (R_{SENSE}) and the sense voltage ($V_{CAP} - V_{LED}$) control the LED current.

The CTRL pin controls the sense reference voltage as shown in the Typical Performance Characteristics. For CTRL higher than 1.5V, the sense reference is 200mV, which results in full LED current. In order to have accurate LED current, precision resistors are preferred (1% is recommended). The formula and table for R_{SENSE} selection are shown below.

$$R_{SENSE} = \frac{200mV}{I_{LED}}$$

APPLICATIONS INFORMATION

Table 4. R_{SENSE} Value Selection for 200mV Sense

I _{LED} (mA)	R _{SENSE} (Ω)
5	40
10	20
15	13.3
20	10

DIMMING CONTROL

There are three different types of dimming control circuits. The LED current can be set by modulating the CTRL pin with a DC voltage, a filtered PWM signal or directly with a PWM signal.

Using a DC Voltage

For some applications, the preferred method of brightness control is a variable DC voltage to adjust the LED current. The CTRL pin voltage can be modulated to set the dimming of the LED string. As the voltage on the CTRL pin increases from 0V to 1.5V, the LED current increases from 0 to I_{LED}. As the CTRL pin voltage increases beyond 1.5V, it has no effect on the LED current.

The LED current can be set by:

$$I_{LED} \approx \frac{200mV}{R_{SENSE}}, \text{ when } V_{CTRL} > 1.5V$$

$$I_{LED} \approx \frac{V_{CTRL}}{6.25 \cdot R_{SENSE}}, \text{ when } V_{CTRL} < 1.25V$$

Feedback voltage variation versus control voltage is given in the Typical Performance Characteristics.

Using a Filtered PWM Signal

A filtered PWM signal can be used to control the brightness of the LED string. The PWM signal is filtered (Figure 5) by a RC network and fed to the CTRL pin.

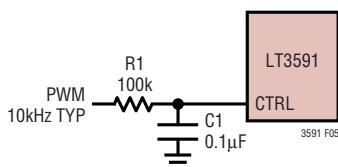

Figure 5. Dimming Control Using a Filtered PWM Signal

The corner frequency of R1, C1 should be much lower than the frequency of the PWM signal. R1 needs to be much smaller than the internal impedance of the CTRL pin which is 10MΩ (typ).

Direct PWM Dimming

Changing the forward current flowing in the LEDs not only changes the intensity of the LEDs, it also changes the color. The chromaticity of the LEDs changes with the change in forward current. Many applications cannot tolerate any shift in the color of the LEDs. Controlling the intensity of the LEDs with a direct PWM signal allows dimming of the LEDs without changing the color. In addition, direct PWM dimming offers a wider dimming range to the user.

Dimming the LEDs via a PWM signal essentially involves turning the LEDs on and off at the PWM frequency. The typical human eye has a limit of ~60 frames per second. By increasing the PWM frequency to ~80Hz or higher, the eye will interpret that the pulsed light source is continuously on. Additionally, by modulating the duty cycle (amount of “on-time”), the intensity of the LEDs can be controlled. The color of the LEDs remains unchanged in this scheme since the LED current value is either zero or a constant value.

Figure 6 shows a Li-Ion powered driver for ten white LEDs. Direct PWM dimming method requires an external NMOS tied between the cathode of the lowest LED in the string

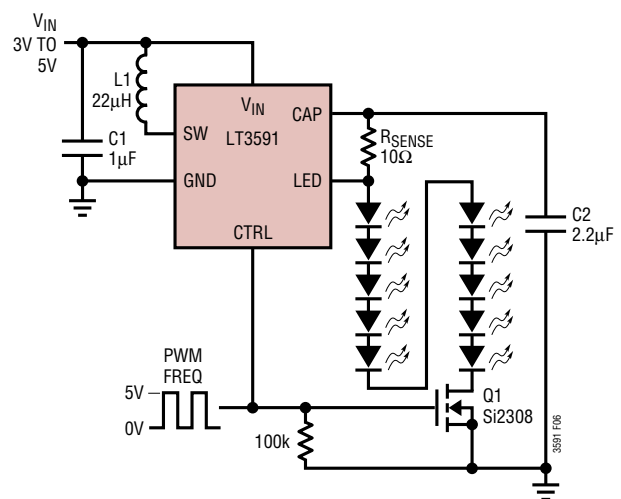

Figure 6. Li-Ion to Ten White LEDs with Direct PWM Dimming

APPLICATIONS INFORMATION

and ground as shown in Figure 6. A Si2308 MOSFET can be used since its source is connected to ground. The PWM signal is applied to the CTRL pin of the LT3591 and the gate of the MOSFET. The PWM signal should traverse between 0V to 5V, to ensure proper turn on and off of the driver and the NMOS transistor Q1. When the PWM signal goes high, the LEDs are connected to ground and a current of $I_{LED} = 200mV/R_{SENSE}$ flows through the LEDs. When the PWM signal goes low, the LEDs are disconnected and turn off. The MOSFET ensures that the LEDs quickly turn off without discharging the output capacitor which in turn allows the LEDs to turn on faster. Figure 7 shows the PWM dimming waveforms for the circuit in Figure 6.

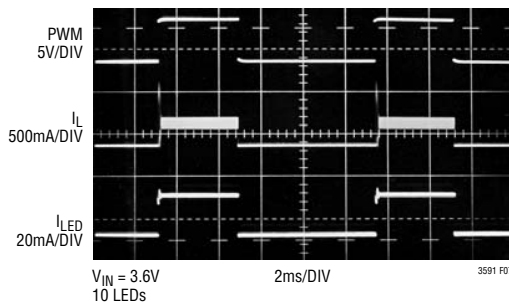

Figure 7. Direct PWM Dimming Waveforms

The time it takes for the LED current to reach its programmed value sets the achievable dimming range for a given PWM frequency. For example, the settling time of the LED current in Figure 7 is approximately 120µs for a 3.6V input voltage. The achievable dimming range for this application and 100Hz PWM frequency can be determined using the following method.

Example:

$$f = 100\text{Hz}, t_{SETTLE} = 120\mu\text{s}$$

$$t_{PERIOD} = \frac{1}{f} = \frac{1}{100} = 0.01\text{s}$$

$$\text{Dim Range} = \frac{t_{PERIOD}}{t_{SETTLE}} = \frac{0.01\text{s}}{120\mu\text{s}} = 83:1$$

$$\text{Min Duty Cycle} = \frac{t_{SETTLE}}{t_{PERIOD}} \cdot 100 = \frac{120\mu\text{s}}{0.01\text{s}} \cdot 100 = 1.2\%$$

$$\text{Duty Cycle Range} = 100\% \rightarrow 1.2\% \text{ at } 100\text{Hz}$$

The calculations show that for a 100Hz signal the dimming range is 83 to 1. In addition, the minimum PWM duty cycle of 1.2% ensures that the LED current has enough time to settle to its final value. Figure 8 shows the dimming range achievable for different frequencies with a settling time of 120µs.

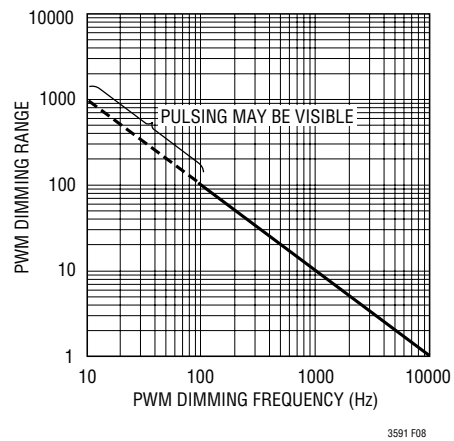

Figure 8. Dimming Range vs Frequency

In addition to extending the dimming range, PWM dimming improves the efficiency of the converter for LED currents below 20mA. Figure 9 shows the efficiency for traditional analog dimming of the front page application and PWM dimming of the application in Figure 6.

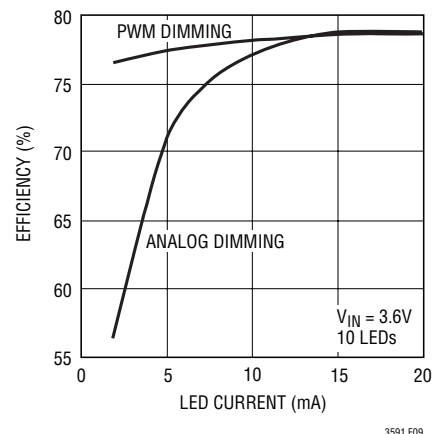

Figure 9. PWM vs Analog Dimming Efficiency

APPLICATIONS INFORMATION

LOW INPUT VOLTAGE APPLICATIONS

The LT3591 can be used in low input voltage applications. The input supply voltage to the LT3591 must be 2.5V or higher. However, the inductor can be run off a lower battery voltage. This technique allows the LEDs to be powered off two alkaline cells. Most portable devices have a 3.3V logic supply voltage which can be used to power the LT3591. The LEDs can be driven straight from the battery, resulting in higher efficiency.

Figure 10 shows six LEDs powered by two AA cells. The battery is connected to the inductor and the chip is powered off a 3.3V logic supply voltage.

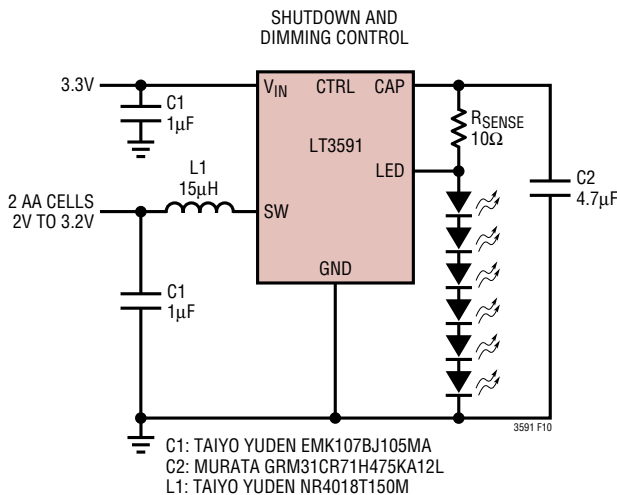

Figure 10. 2 AA Cells to Six White LEDs

BOARD LAYOUT CONSIDERATIONS

As with all switching regulators, careful attention must be paid to the PCB board layout and component placement. To prevent electromagnetic interference (EMI) problems, proper layout of high frequency switching paths is essential. Minimize the length and area of all traces connected to the switching node pin (SW). Keep the sense voltage pins (CAP and LED) away from the switching node. Place C_{OUT} next to the CAP pin. Always use a ground plane under the switching regulator to minimize interplane coupling. Recommended component placement is shown in Figure 11.

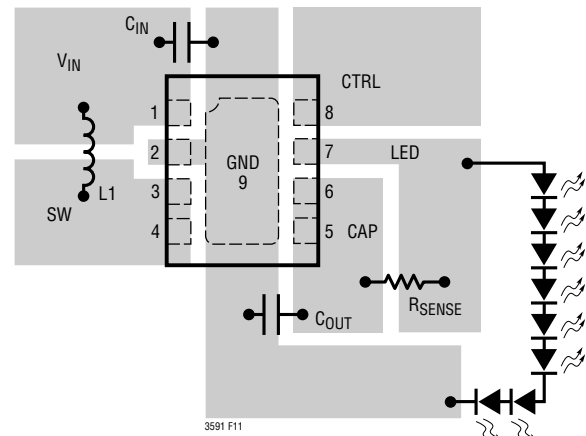
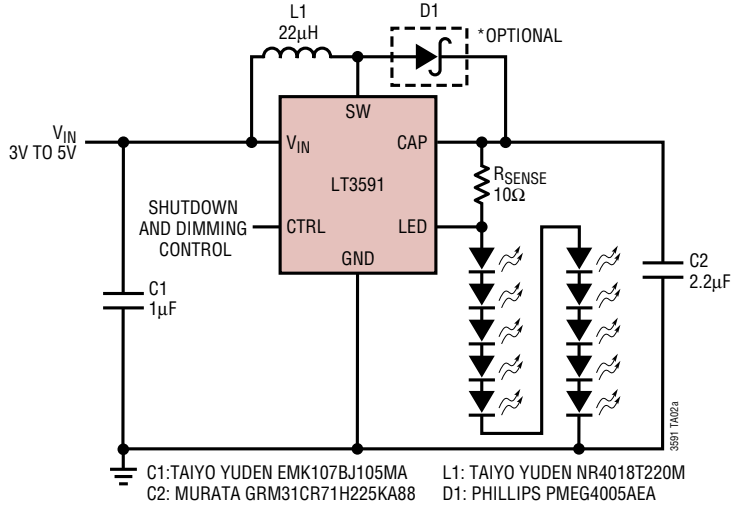

Figure 11. Recommended Component Placement

TYPICAL APPLICATIONS

Li-Ion Driver for Ten White LEDs



Efficiency

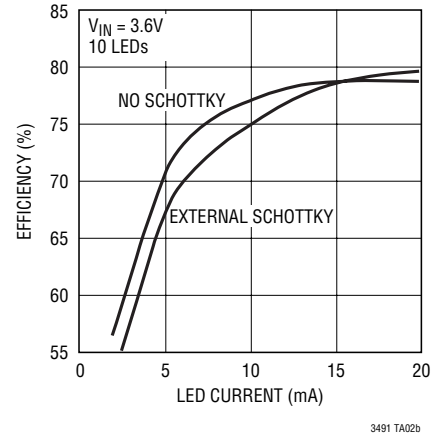

Li-Ion Driver for Four White LEDs at 50mA

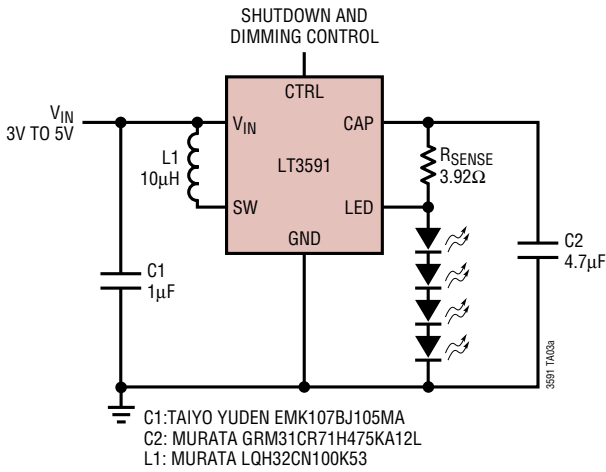

Efficiency

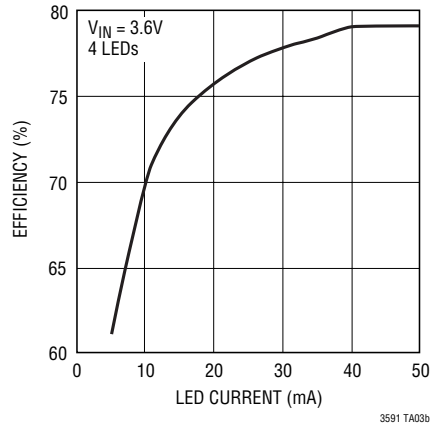

TYPICAL APPLICATIONS

24V to Four White LEDs at 100mA

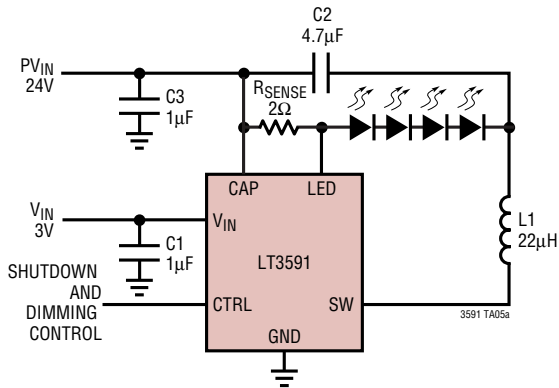

- C1: TAIYO YUDEN EMK107BJ105MA
- C2: MURATA GRM31CR71H475KA12L
- C3: MURATA GRM21BR71H105KA12L
- L1: TAIYO YUDEN NR4018T220M

Efficiency

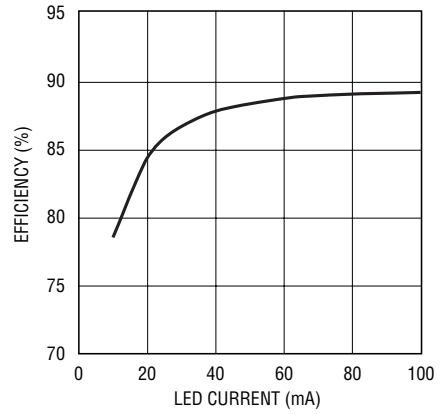

3591 TA05b

24V to Five White LEDs at 100mA

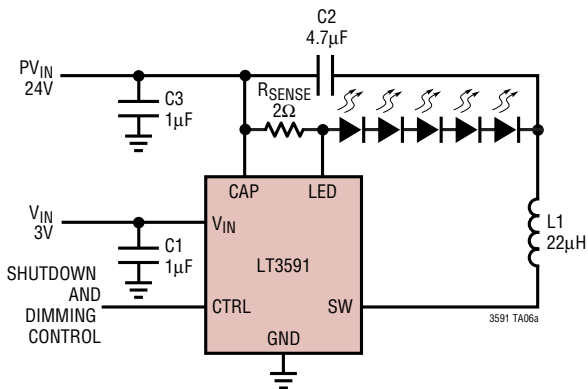

- C1: TAIYO YUDEN EMK107BJ105MA
- C2: MURATA GRM31CR71H475KA12L
- C3: MURATA GRM21BR71H105KA12L
- L1: TAIYO YUDEN NR4018T220M

Efficiency

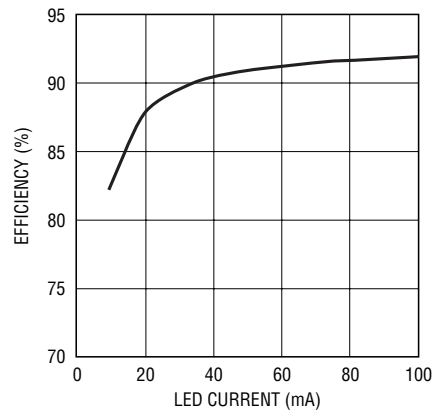

3591 TA06b

TYPICAL APPLICATIONS

Li-Ion Driver for Seven White LEDs

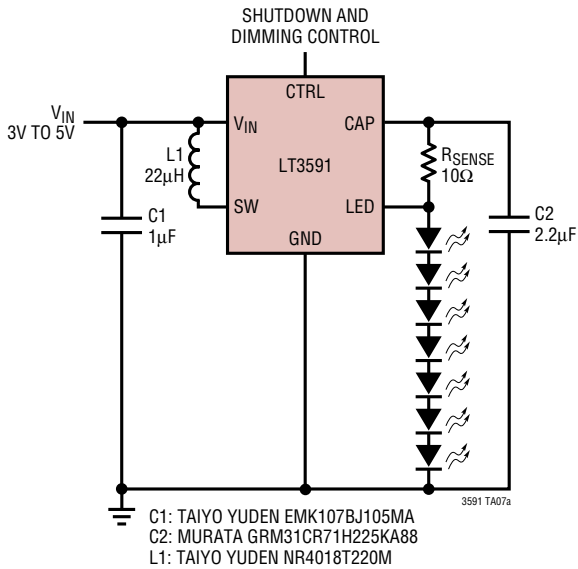

Conversion Efficiency

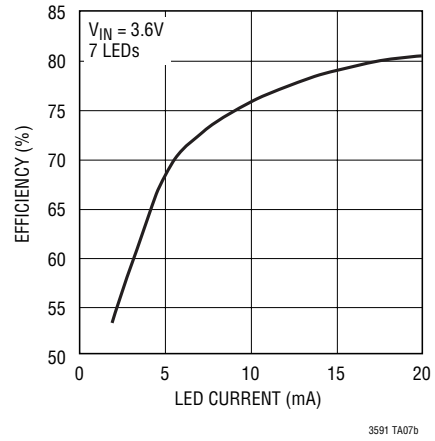

Li-Ion Driver for Eight White LEDs

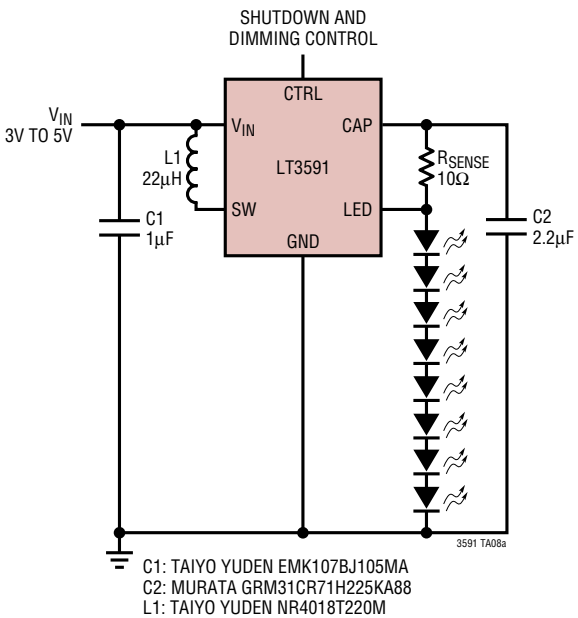

Conversion Efficiency

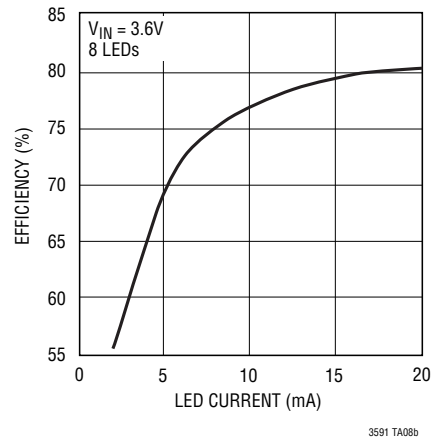

PACKAGE DESCRIPTION

DDB Package
8-Lead Plastic DFN (3mm × 2mm)
 (Reference LTC DWG # 05-08-1702 Rev B)

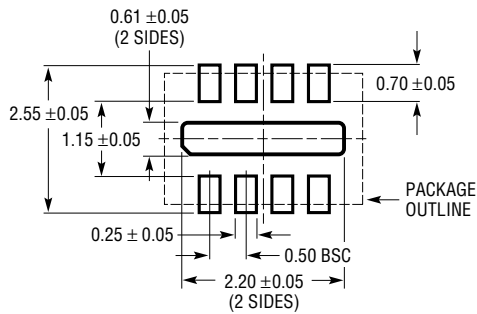

RECOMMENDED SOLDER PAD PITCH AND DIMENSIONS

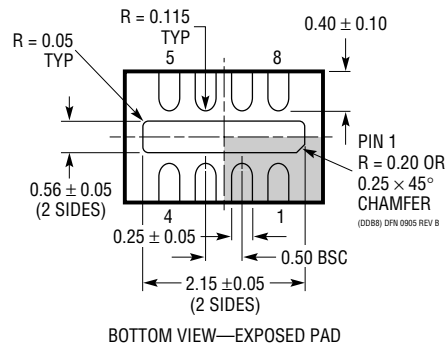
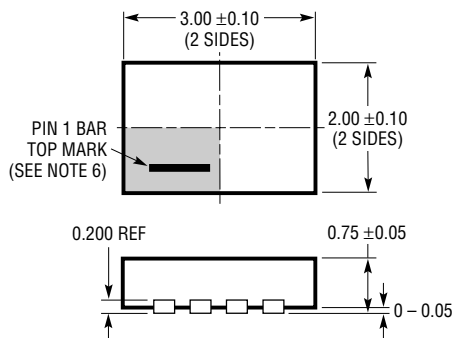

- NOTE:
1. DRAWING CONFORMS TO VERSION (WECD-1) IN JEDEC PACKAGE OUTLINE M0-229
 2. DRAWING NOT TO SCALE
 3. ALL DIMENSIONS ARE IN MILLIMETERS
 4. DIMENSIONS OF EXPOSED PAD ON BOTTOM OF PACKAGE DO NOT INCLUDE MOLD FLASH. MOLD FLASH, IF PRESENT, SHALL NOT EXCEED 0.15mm ON ANY SIDE
 5. EXPOSED PAD SHALL BE SOLDER PLATED
 6. SHADED AREA IS ONLY A REFERENCE FOR PIN 1 LOCATION ON THE TOP AND BOTTOM OF PACKAGE

TYPICAL APPLICATION

Li-Ion Driver for Nine White LEDs

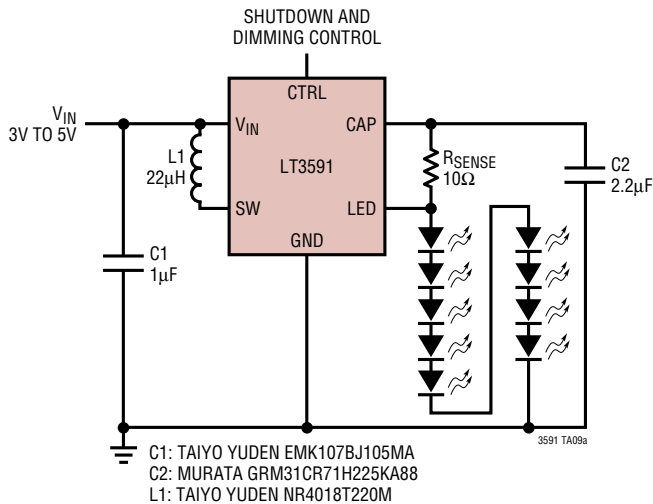

Conversion Efficiency

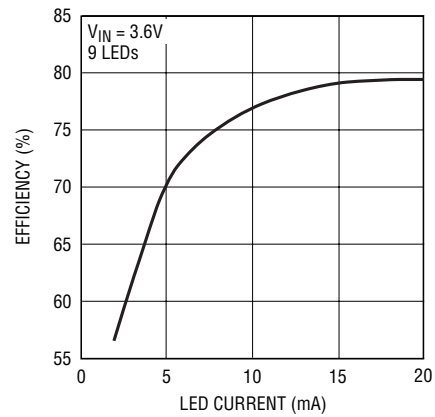

RELATED PARTS

PART NUMBER	DESCRIPTION	COMMENTS
LT1618	Constant-Current, Constant Voltage 1.24MHz, High Efficiency Boost Regulator	Up to 16 White LEDs, V_{IN} : 1.6V to 18V, $V_{OUT(MAX)}$ = 34V, I_Q = 1.8mA, I_{SD} < 1µA, MS Package
LT1937	Constant-Current, 1.2MHz, High Efficiency White LED Boost Regulator	Up to 4 White LEDs, V_{IN} : 2.5V to 10V, $V_{OUT(MAX)}$ = 34V, I_Q = 1.9mA, I_{SD} < 1µA, ThinSOT™/SC70 Packages
LTC®3200	Low Noise, 2MHz Regulated Charge Pump White LED Driver	Up to 6 White LEDs, V_{IN} : 2.7V to 4.5V, I_Q = 8mA, I_{SD} < 1µA, MS Package
LTC3200-5	Low Noise, 2MHz Regulated Charge Pump White LED Driver	Up to 6 White LEDs, V_{IN} : 2.7V to 4.5V, I_Q = 8mA, I_{SD} < 1µA, ThinSOT Package
LTC3201	Low Noise, 1.7MHz Regulated Charge Pump White LED Driver	Up to 6 White LEDs, V_{IN} : 2.7V to 4.5V, I_Q = 6.5mA, I_{SD} < 1µA, MS Package
LTC3202	Low Noise, 1.5MHz Regulated Charge Pump White LED Driver	Up to 8 White LEDs, V_{IN} : 2.7V to 4.5V, I_Q = 5mA, I_{SD} < 1µA, MS Package
LTC3205	High Efficiency, Multidisplay LED Controller	Up to 4 (Main), 2 (Sub) and RGB, V_{IN} : 2.8V to 4.5V, I_Q = 50µA, I_{SD} < 1µA, 24-Lead QFN Package
LT3465/LT3465A	Constant-Current, 1.2MHz/2.7MHz, High Efficiency White LED Boost Regulator with Integrated Schottky Diode	Up to 6 White LEDs, V_{IN} : 2.7V to 16V, $V_{OUT(MAX)}$ = 34V, I_Q = 1.9mA, I_{SD} < 1µA, ThinSOT Package
LT3466/LT3466-1	Dual Full Function, 2MHz Diodes White LED Step-Up Converter with Built-In Schottkys	Up to 20 White LEDs, V_{IN} : 2.7V to 24V, $V_{OUT(MAX)}$ = 39V, DFN, TSSOP-16 Packages
LT3486	Dual 1.3A White LED Converter with 1000:1 True Color PWM Dimming	Drives Up to 16 100mA White LEDs. V_{IN} : 2.5V to 24V, $V_{OUT(MAX)}$ = 36V, DFN, TSSOP Packages
LT3491	2.3MHz White LED Driver with Integrated Schottky Diode	Drives Up to 6 LEDs. V_{IN} : 2.5V to 12V, $V_{OUT(MAX)}$ = 27V, SC70 and DFN Packages
LT3497	Dual Full Function 2.3MHz LED Driver with 250:1 True Color PWM Dimming with Integrated Schottky Diodes	Up to 12 White LEDs, V_{IN} : 2.5V to 10V, $V_{OUT(MAX)}$ = 32V, 3mm × 2mm DFN Package

ThinSOT is a trademark of Linear Technology Corporation