

LINEAR SYSTEMS

Linear Integrated Systems

LS301 LS302 LS303

HIGH VOLTAGE SUPER-BETA MONOLITHIC DUAL NPN TRANSISTORS

FEATURES		
VERY HIGH GAIN	$h_{FE} \geq 2000$ @ 1.0 μ A TYP.	
LOW OUTPUT CAPACITANCE	$C_{OBO} \leq 2.0$ pF	
TIGHT V_{BE} MATCHING	$ V_{BE1} - V_{BE2} = 0.2$ mV TYP.	
HIGH f_T	100MHz	
ABSOLUTE MAXIMUM RATINGS NOTE 1 @ 25°C (unless otherwise noted)		
I_C	Collector Current	5mA
Maximum Temperatures		
Storage Temperature		-65° to +200°C
Operating Junction Temperature		+150°C
Maximum Power Dissipation		ONE SIDE
Device Dissipation @ Free Air		250mW
Linear Derating Factor		2.3mW/°C
		BOTH SIDES
Device Dissipation @ Free Air		500mW
Linear Derating Factor		4.3mW/°C

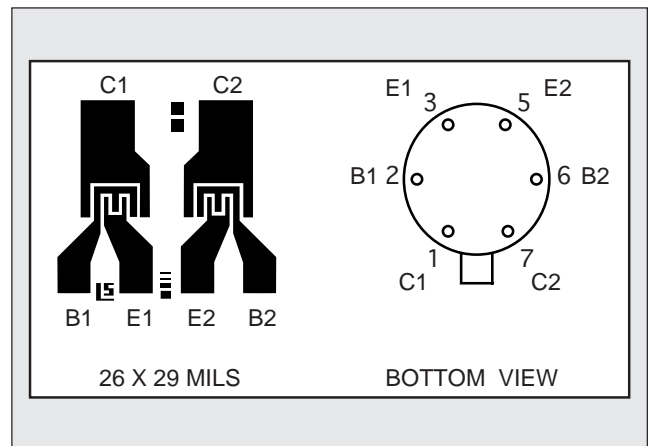

ELECTRICAL CHARACTERISTICS @ 25°C (unless otherwise noted)

SYMBOL	CHARACTERISTICS	LS301	LS302	LS303		UNITS	CONDITIONS
BV_{CBO}	Collector to Base Voltage	18	35	10	MIN.	V	$I_C = 10\mu$ A $I_E = 0$
BV_{CEO}	Collector to Emitter Voltage	18	35	10	MIN.	V	$I_C = 10\mu$ A $I_B = 0$
BV_{EBO}	Emitter-Base Breakdown Voltage	6.2	6.2	6.2	MIN.	V	$I_E = 10\mu$ A $I_C = 0$ NOTE 2
BV_{CCO}	Collector to Collector Voltage	100	100	100	MIN.	V	$I_C = 10\mu$ A $I_E = 0$
h_{FE}	DC Current Gain	2000	1000	2000	TYP.		$I_C = 1\mu$ A $V_{CE} = 5$ V
h_{FE}	DC Current Gain	2000	1000	2000	MIN.		$I_C = 10\mu$ A $V_{CE} = 5$ V
h_{FE}	DC Current Gain	2000	1000	2000	TYP.		$I_C = 500\mu$ A $V_{CE} = 5$ V
$V_{CE(SAT)}$	Collector Saturation Voltage	0.5	0.5	0.5	MAX.	V	$I_C = 1$ mA $I_B = 0.1$ mA
I_{CBO}	Collector Cutoff Current	100	100	100	MAX.	pA	$I_E = 0$ $V_{CB} =$ NOTE 3
I_{EBO}	Emitter Cutoff Current	0.2	0.2	0.2	MAX.	pA	$I_E = 0$ $V_{EB} = 3$ V
C_{OBO}	Output Capacitance	2	2	2	MAX.	pF	$I_E = 0$ $V_{CB} = 1$ V
C_{C1C2}	Collector to Collector Capacitance	2	2	2	MAX.	pF	$V_{CC} = 0$
I_{C1C2}	Collector to Collector Leakage Current	0.5	0.5	0.5	MAX.	nA	$V_{CC} =$ NOTE 4
f_T	Current Gain Bandwidth Product	100	100	100	MIN.	MHz	$I_C = 200\mu$ A $V_{CE} = 5$ V
NF	Narrow Band Noise Figure	3	3	3	MAX.	dB	$I_C = 10\mu$ A $V_{CE} = 3$ V BW = 200Hz $R_G = 10$ K Ω f = 1KHz

Linear Integrated Systems

4042 Clipper Court, Fremont, CA 94538 • TEL: (510) 490-9160 • FAX: (510) 353-0261

MATCHING CHARACTERISTICS

SYMBOL	CHARACTERISTICS	LS301	LS302	LS303		UNITS	CONDITIONS
$ V_{BE1} - V_{BE2} $	Base Emitter Voltage Differential	0.2	0.2	0.2	TYP.	mV	$I_C = 10 \mu A$ $V_{CE} = 5V$
		1	1	1	MAX.	mV	
$\Delta (V_{BE1} - V_{BE2}) /^\circ C$	Base Emitter Voltage Differential Change with Temperature	1	1	1	TYP.	$\mu V/^\circ C$	$I_C = 10 \mu A$ $V_{CE} = 5V$ $T = -55^\circ C$ to $+125^\circ C$
		5	5	5	MAX.	$\mu V/^\circ C$	
$ I_{B1} - I_{B2} $	Base Current Differential	0.5	1	0.5	TYP.	nA	$I_C = 10 \mu A$ $V_{CE} = 1V$
		1	5	1.5	MAX.	nA	
h_{FE1}/h_{FE2}	DC Current Gain Differential	5	5	5	TYP.	%	$I_C = 10 \mu A$ $V_{CE} = 5V$

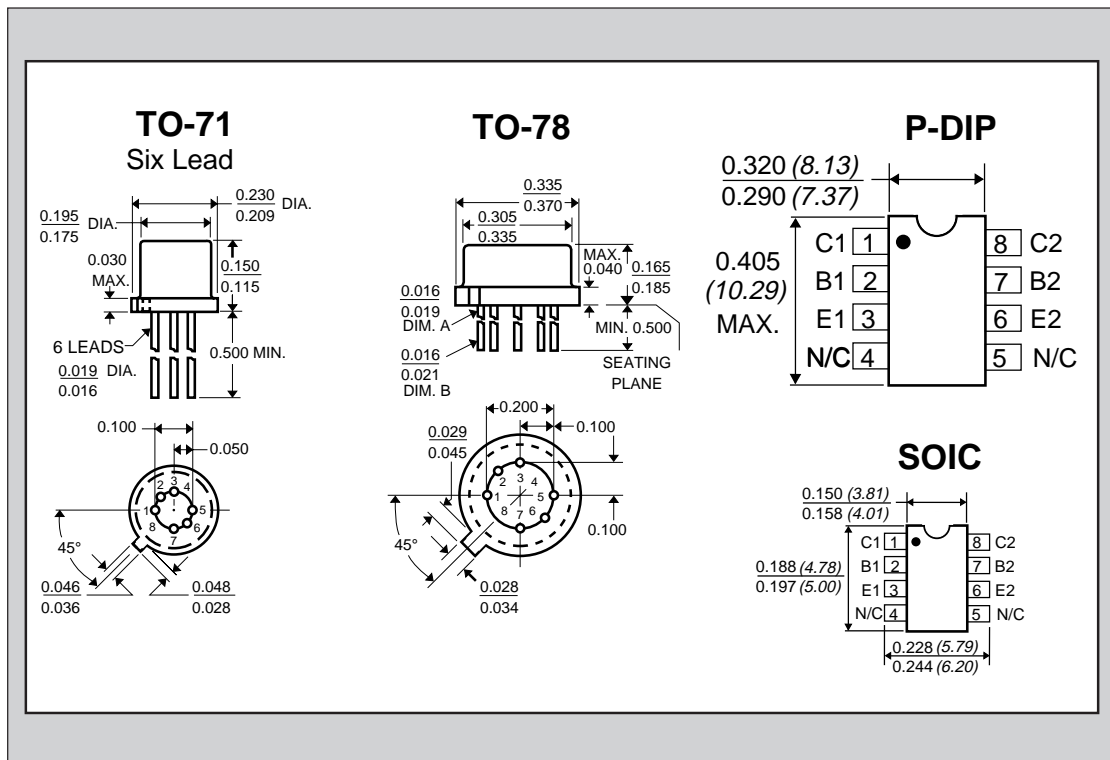

NOTES:

1. These ratings are limiting values above which the serviceability of any semiconductor may be impaired.
2. The reverse base-to-emitter voltage must never exceed 6.2 volts; the reverse base-to-emitter current must never exceed 10 μA mps.
3. For LS301 & LS302: $V_{CB} = 10V$; for LS303: $V_{CB} = 5V$.
4. For LS301 & LS302: $V_{CC} = \pm 80V$; for LS303: $V_{CC} = \pm 20V$.