

LINEAR SYSTEMS

Linear Integrated Systems

LS843 LS844 LS845

ULTRA LOW NOISE LOW DRIFT
MONOLITHIC DUAL N-CANNEL JFET

FEATURES	
ULTRA LOW NOISE	$e_n = 3nV/\sqrt{Hz}$ TYP.
LOW LEAKAGE	$I_G = 15pA$ TYPs.
LOW DRIFT	$ \Delta V_{GS1-2}/\Delta T = 5\mu V/^\circ C$ max.
ULTRA LOW OFFSET VOLTAGE	$ V_{GS1-2} = 1mV$ max.
ABSOLUTE MAXIMUM RATINGS NOTE 1 @ 25°C (unless otherwise noted)	
Maximum Temperatures	
Storage Temperature	-65° to +150°C
Operating Junction Temperature	+150°C
Maximum Voltage and Current for Each Transistor NOTE 1	
$-V_{GSS}$	Gate Voltage to Drain or Source 60V
$-V_{DSO}$	Drain to Source Voltage 60V
$-I_{G(f)}$	Gate Forward Current 50mA
Maximum Power Dissipation	
Device Dissipation @ Free Air - Total	400mW @ +125°C

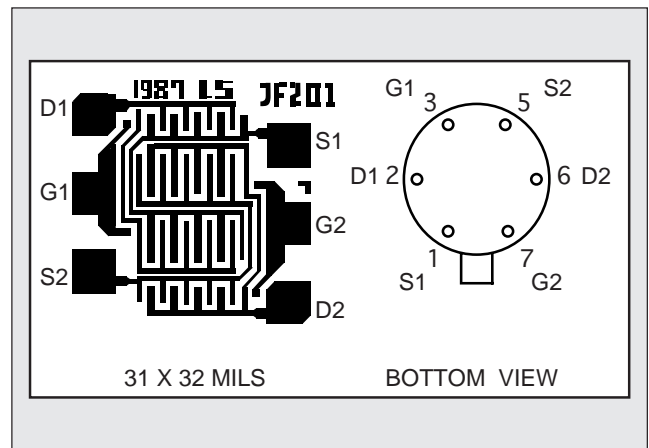

ELECTRICAL CHARACTERISTICS @ 25°C (unless otherwise noted)

SYMBOL	CHARACTERISTICS	LS843	LS844	LS845	UNITS	CONDITIONS
$ \Delta V_{GS1-2}/\Delta T $ max.	Drift vs. Temperature	5	10	25	$\mu V/^\circ C$	$V_{DG} = 10V$ $T_A = -55^\circ C$ to $+125^\circ C$ $I_D = 500\mu A$
$ V_{GS1-2} $ max.	Offset Voltage	1	5	15	mV	$V_{DG} = 10V$ $I_D = 500\mu A$

SYMBOL	CHARACTERISTICS	MIN.	TYP.	MAX.	UNITS	CONDITIONS
BV_{GSS}	Breakdown Voltage	60	--	--	V	$V_{DS} = 0$ $I_D = 1nA$
BV_{GGO}	Gate-to-Gate Breakdown	60	--	--	V	$I_G = 1nA$ $I_D = 0$ $I_S = 0$
TRANSCONDUCTANCE						
Y_{fss}	Full Conduction	1500	--	--	μmho	$V_{DG} = 15V$ $V_{GS} = 0$ $f = 1kHz$
Y_{fs}	Typical Conduction	1000	1500	--	μmho	$V_{DG} = 15V$ $I_D = 500\mu A$
$ Y_{fs1-2}/Y_{fs} $	Mismatch	--	0.6	3	%	
DRAIN CURRENT						
I_{DSS}	Full Conduction	1.5	5	15	mA	$V_{DG} = 15V$ $V_{GS} = 0$
$ I_{DSS1-2}/I_{DSS} $	Mismatch at Full Conduction	--	1	5	%	
GATE VOLTAGE						
$V_{GS(off)}$ or V_P	Pinchoff Voltage	1	--	3.5	V	$V_{DS} = 15V$ $I_D = 1nA$
V_{GS}	Operating Range	0.5	--	3.5	V	$V_{DS} = 15V$ $I_D = 500\mu A$
GATE CURRENT						
$-I_G$	Operating	--	15	50	μA	$V_{DG} = 15V$ $I_D = 500\mu A$
$-I_G$	High Temperature	--	--	50	nA	$V_{DG} = 15V$ $I_D = 500\mu A$ $T_A = +125^\circ C$
$-I_G$	Reduced VDG	--	5	30	μA	$V_{DG} = 3V$ $I_D = 500\mu A$
$-I_{GSS}$	At Full Conduction	--	--	100	μA	$V_{DG} = 15V$ $V_{DS} = 0$

Linear Integrated Systems

4042 Clipper Court, Fremont, CA 94538 • TEL: (510) 490-9160 • FAX: (510) 353-0261

SYMBOL	CHARACTERISTICS	MIN.	TYP.	MAX.	UNITS	CONDITIONS
	OUTPUT CONDUCTANCE					
Y_{OSS}	Full Conduction	--	--	20	μmho	$V_{DG} = 15\text{V}$ $V_{GS} = 0$
Y_{OS}	Operating	--	0.2	2	μmho	$V_{DG} = 15\text{V}$ $I_D = 500\mu\text{A}$
$ Y_{OS1-2} $	Differential	--	0.02	0.2	μmho	
	COMMON MODE REJECTION					
CMR	$-20 \log \Delta V_{GS1-2} / \Delta V_{DS} $	90	110	--	dB	$\Delta V_{DS} = 10 \text{ to } 20\text{V}$ $I_D = 500\mu\text{A}$
CMR		--	85	--	dB	$\Delta V_{DS} = 5 \text{ to } 10\text{V}$ $I_D = 500\mu\text{A}$
	NOISE					
NF	Figure	--	--	0.5	dB	$V_{DS} = 15\text{V}$ $V_{GS} = 0$ $R_G = 10\text{M}\Omega$ $f = 100\text{Hz}$ $\text{NBW} = 6\text{Hz}$
e_n	Voltage	--	--	7	$\text{nV}/\sqrt{\text{Hz}}$	$V_{DS} = 15\text{V}$ $I_D = 500\mu\text{A}$ $f = 1\text{kHz}$ $\text{NBW} = 1\text{Hz}$
e_n	Voltage	--	--	11	$\text{nV}/\sqrt{\text{Hz}}$	$V_{DS} = 15\text{V}$ $I_D = 500\mu\text{A}$ $f = 10\text{Hz}$ $\text{NBW} = 1\text{Hz}$
	CAPACITANCE					
C_{ISS}	Input	--	--	8	pF	$V_{DS} = 15\text{V}$ $I_D = 500\mu\text{A}$
C_{RSS}	Reverse Transfer	--	--	3	pF	
C_{DD}	Drain-to-Drain	--	0.5	--	pF	$V_{DG} = 15\text{V}$ $I_D = 500\mu\text{A}$

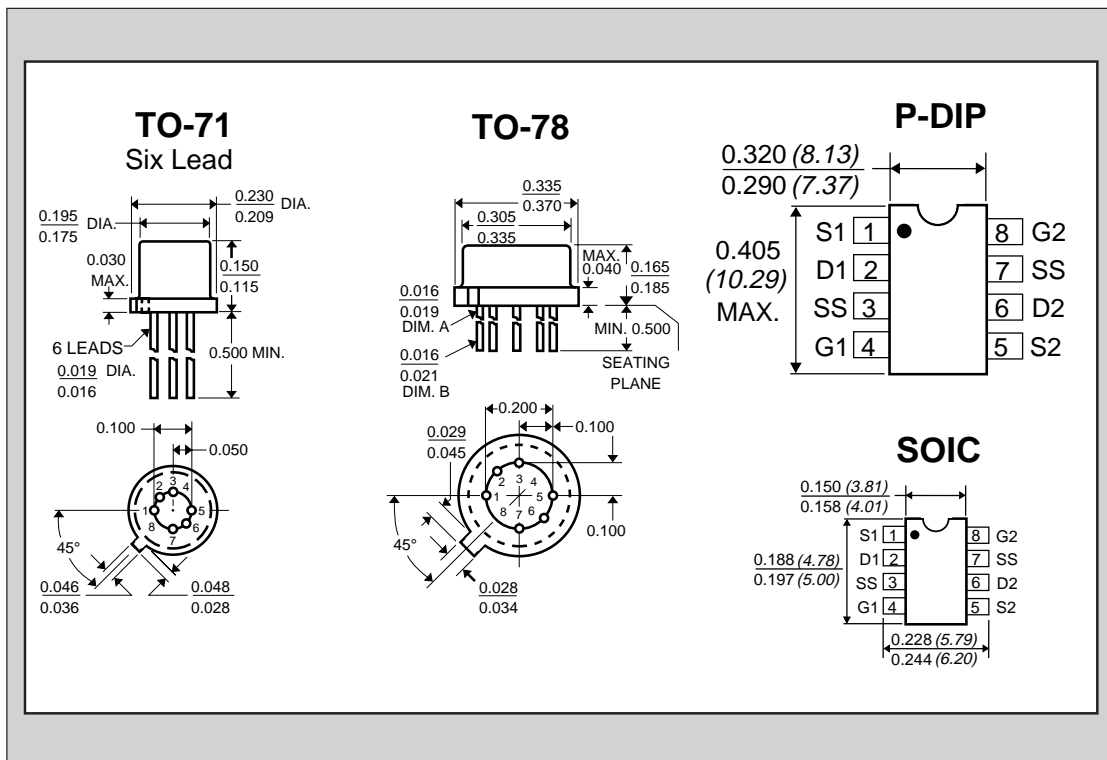

NOTES:

1. These ratings are limiting values above which the serviceability of any semiconductor may be impaired.