

SCHOTTKY BARRIER RECTIFIERS

REVERSE VOLTAGE - 30 to 60 Volts
FORWARD CURRENT - 16 Amperes

FEATURES

- Metal of silicon rectifier, majority carrier conduction
- Guard ring for transient protection
- Low power loss, high efficiency
- High current capability, low VF
- High surge capacity
- Plastic package has UL flammability classification 94V-0
- For use in low voltage, high frequency inverters, free wheeling, and polarity protection applications

MECHANICAL DATA

- Case : TO-3P molded plastic
- Polarity : As marked on the body
- Weight : 0.2 ounces, 5.6 grams
- Mounting position : Any

TO-3P

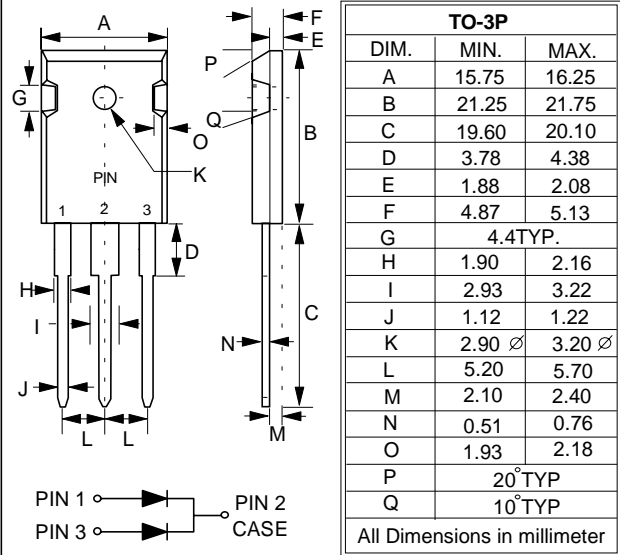

MAXIMUM RATINGS AND ELECTRICAL CHARACTERISTICS

Ratings at 25°C ambient temperature unless otherwise specified.
Single phase, half wave, 60Hz, resistive or inductive load.
For capacitive load, derate current by 20%

CHARACTERISTICS	SYMBOL	SBL 1630PT	SBL 1635PT	SBL 1640PT	SBL 1645PT	SBL 1650PT	SBL 1660PT	UNIT
Maximum Recurrent Peak Reverse Voltage	VRRM	30	35	40	45	50	60	V
Maximum RMS Voltage	VRMS	21	24.5	28	31.5	35	42	V
Maximum DC Blocking Voltage	VDC	30	35	40	45	50	60	V
Maximum Average Forward Rectified Current @TC=95°C	I(AV)	16						A
Peak Forward Surge Current 8.3ms single half sine-wave superimposed on rated load (JEDEC METHOD)	IFSM	250						A
Maximum forward Voltage at 8A DC (Note 3)	VF	0.55				0.70		V
Maximum DC Reverse Current at Rated DC Blocking Voltage @TJ=25°C @TJ=100°C	IR	0.5				50		mA
Typical Junction Capacitance per element (Note1)	CJ	500						pF
Typical Thermal Resistance (Note 2)	RθJC	3.5						°C/W
Operating Temperature Range	TJ	-55 to +125						°C
Storage Temperature Range	TSTG	-55 to +150						°C

NOTES : 1. Measured at 1.0MHz and applied reverse voltage of 4.0V DC.
2. Thermal Resistance Junction to Case.
3. 300us Pulse Width, 2% Duty Cycle.

FIG.1 - FORWARD CURRENT DERATING CURVE

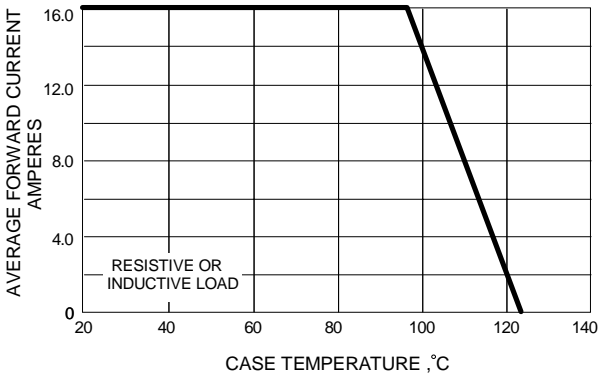

FIG.2 - MAXIMUM NON-REPETITIVE SURGE CURRENT

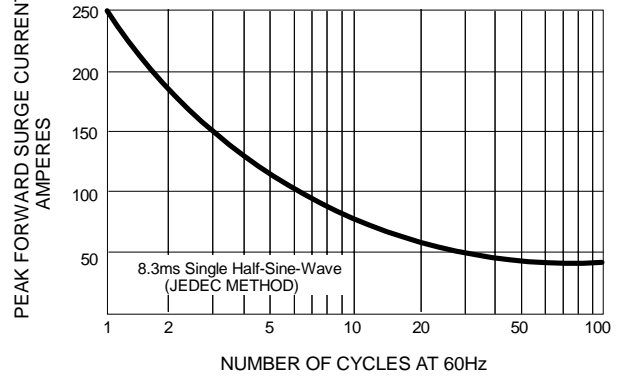

FIG.3 - TYPICAL REVERSE CHARACTERISTICS

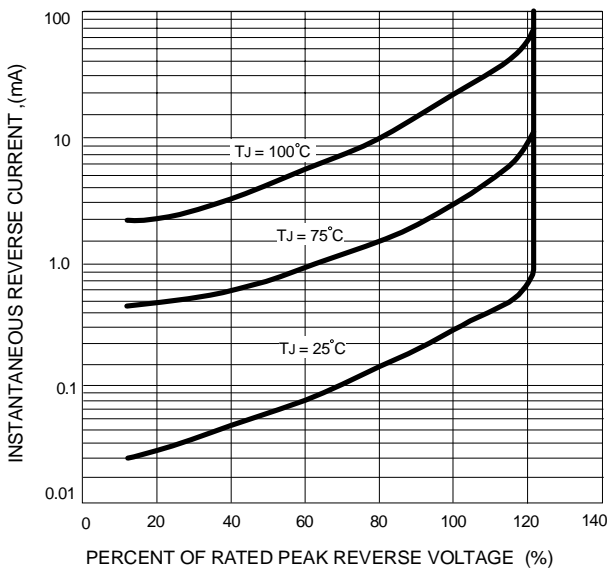

FIG.4 - TYPICAL FORWARD CHARACTERISTICS

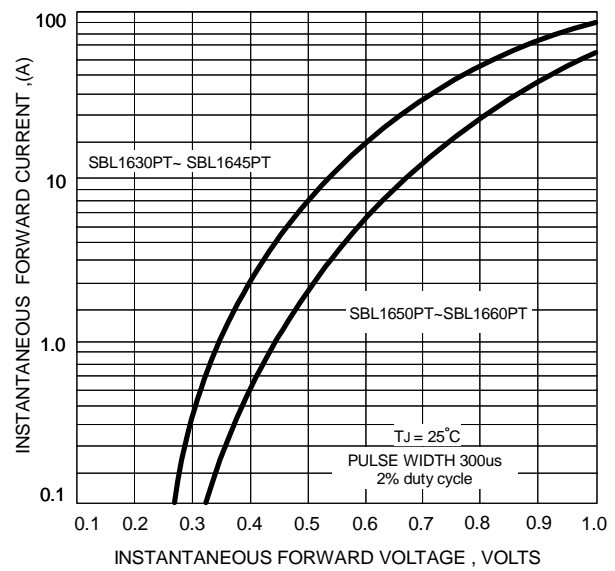

FIG.5 - TYPICAL JUNCTION CAPACITANCE

