

LSI/CSI

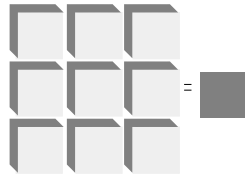

LS7310-7313



LSI Computer Systems, Inc. 1235 Walt Whitman Road, Melville, NY 11747 (631) 271-0400 FAX (631) 271-0405

AC POWER CONTROLLERS

January 1997

FEATURES:

- 10 I/Os to Select/Indicate up to ten Power Levels
- Inputs activated by Touch or Pushbutton Switch
- Output switches pure and precise AC Power to Load
- Operates with 50Hz/60Hz line frequency
- Rugged, latchup-free process technology
- +10V to +14V operation (V_{SS}-V_{DD})
- LS7310 thru LS7313 (DIP);
LS7310-S thru LS7313-S (SOIC) - See Figure 1

APPLICATIONS:

Universal and shaded-pole motor speed control for modern appliance designs. Eliminates awkward mechanical switch assemblies and multi-tapped motor windings.

DESCRIPTION:

The LS7310-LS7313 are MOS integrated circuits specifically designed for motor speed control applications in appliances such as blenders, etc. I/Os (PLs) are provided for selecting/indicating from one to ten power levels. The LS7310 and 7311 are designed for pushbutton control. The LS7312 and LS7313 are designed for touch control. (See Fig.4A and 4B)

INPUT/OUTPUT DESCRIPTION:

PL1-PL10 (Pins 1-9, 18)

Ten inputs/outputs for selecting ten output phase angles (power levels). When no power level is selected (such as after system power-up), PL1-PL10 all act as inputs. When a power level is selected by applying a logic zero at one of these inputs for T_H time (See Dynamic Characteristics), the selected input switches status to become an output in order to drive a display, such as an LED. It switches back to the input state only when another PL input is activated. (See Note 1)

RUN (Pin 13)

When a logic 0 is applied to the RUN input for T_H time, the output (TRIG) is turned on at a phase angle selected earlier by one of the PL I/Os. If no power level was selected prior to the application of the RUN input, the circuit remains unaffected. Note that once the TRIG output has been enabled, its phase angle can be altered by applying any other PL input without the need to apply the RUN input again. (See Note 1)

OFF (Pin 11)

When a logic 0 is applied to this input for T_H time, TRIG output is turned off, if it was on. If TRIG was already off, the circuit remains unaffected. Note that OFF input does not alter the power level selected by a PL input. Following an OFF operation, TRIG can be turned on at the previous phase angle by applying the RUN input. (See Note 1)

CONNECTION DIAGRAM - TOP VIEW

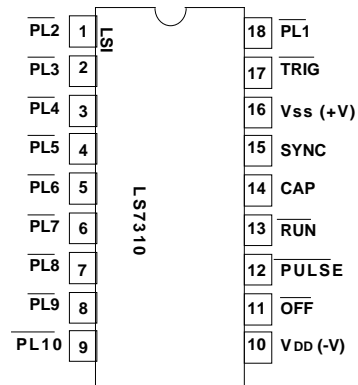

FIGURE 1

PULSE (Pin 12)

A logic 0 applied to this input turns the TRIG output on for as long as the PULSE input is maintained. The PULSE input however, has no effect if no power level is in selection or if the TRIG output has already been turned on by means of the RUN input. (See Note 1)

SYNC (Pin 15)

Input for PLL reference frequency (50Hz/60Hz). All internal clock frequencies are synchronized with the SYNC input.

CAP (Pin 14)

Input for component connection for the PLL filter capacitor.

TRIG (Pin 17)

This output is designed to drive a triac in series with the load and control its firing angle with respect to the AC line. The LS7310 and LS7312 provide a nominal 33μs output pulse width. Since some motors have large inductive loads producing a large phase delay between voltage and current, a wider output pulse may be required. The LS7311 and LS7313 produce a 1ms output pulse width. Otherwise, these parts are identical to the LS7310 and LS7312, respectively.

VSS (Pin 16)

Supply voltage positive terminal.

VDD (Pin 10)

Supply voltage negative terminal (ground).

NOTE 1: LS7310, LS7311 have an internal pullup resistor on this input and LS7312, LS7313 do not. (See DC Electrical Characteristics.)

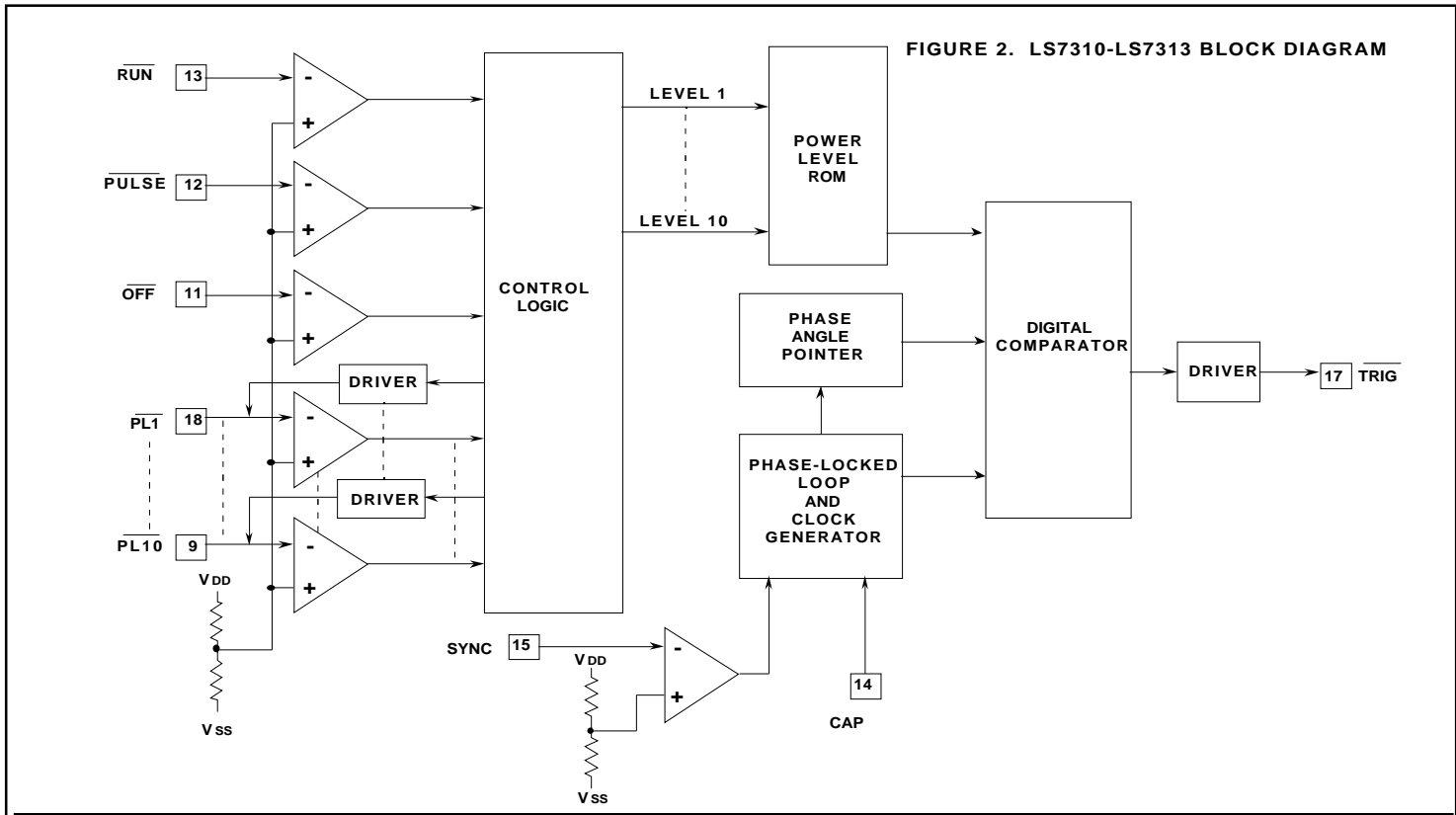

FIGURE 2. LS7310-LS7313 BLOCK DIAGRAM

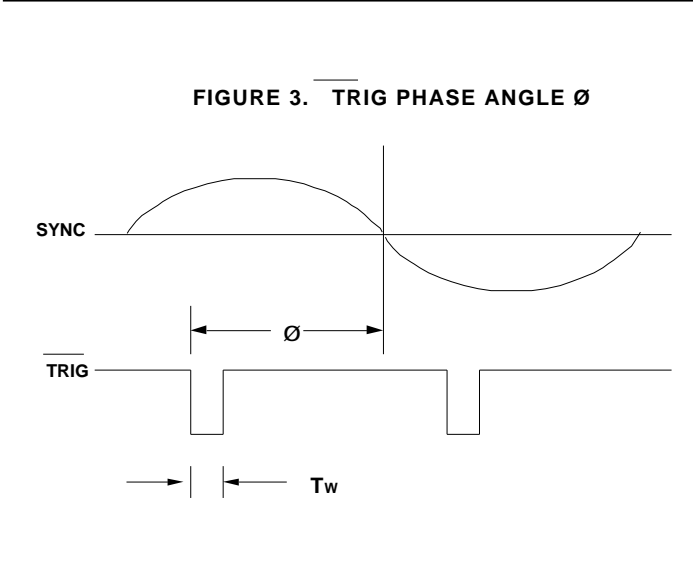

FIGURE 3. TRIG PHASE ANGLE Ø

TABLE 1. TRIG PHASE ANGLES (1)

PL INPUT	TRIG Ø	LOAD POWER % (2)
1	78°	37
2	86°	46
3	93°	53
4	100°	60
5	107°	69
6	112°	74
7	119°	79
8	127°	86
9	137°	92
10	149°	97

- (1) The TRIG Phase Angles shown in TABLE 1 are referenced to the SYNC input. In the Application Schematic shown in Figure 4A, SYNC is delayed by 7° from the AC line. Therefore, actual Phase Angles with respect to the AC line are 7° less than TABLE 1 values. TABLE 1 values are mask programmable.
- (2) The percentage of Full Power delivered to a resistive load by the Triac Switch.

FIGURE 4 VALUE TABLE

CONDITION	C2(µF)	C5(µF)
(1), (3), (5)	0.22	100
(1), (3), (6)	0.10	100
(1), (4), (5)	0.47	220
(1), (4), (6)	0.33	220
(2), (3), (5)	0.47	220
(2), (3), (6)	0.33	220
(2), (4), (5)	0.68	220
(2), (4), (6)	0.47	220

- (1) 33µs TRIG pulse (LS7310, LS7312)
- (2) 1ms TRIG pulse (LS7311, LS7313)
- (3) No LEDs
- (4) 5mA LEDs
- (5) 115VAC, C2 = 200V
- (6) 220VAC, C2 = 400V

FIGURE 4 NOTES

- NOTE 1: Value for 5mA LEDs
- NOTE 2: Use zener which produces 6.2V ±5% at 500µA or less, i. e. P/N MZ4627
- NOTE 3: R6-C6 Snubber Network may be required for large inductive loads.
- NOTE 4: Tie all unused touch inputs together and return to Vss through 100k Ohm, 1/4W resistor.

FIGURE 4A. APPLICATION SCHEMATIC FOR LS7310-LS7313

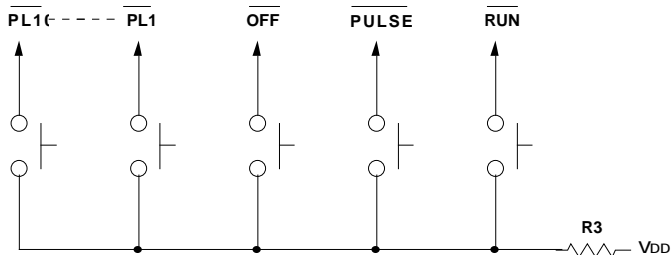
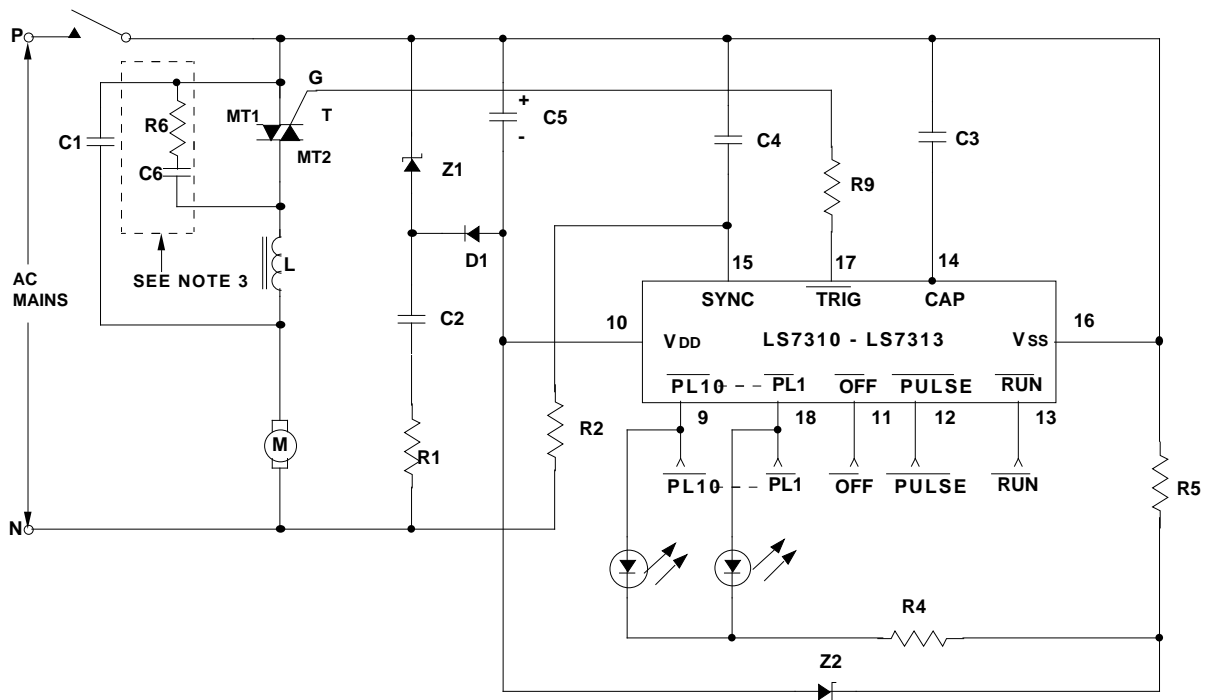

FIGURE 4B. PUSHBUTTON INTERFACE FOR LS7310, LS7311

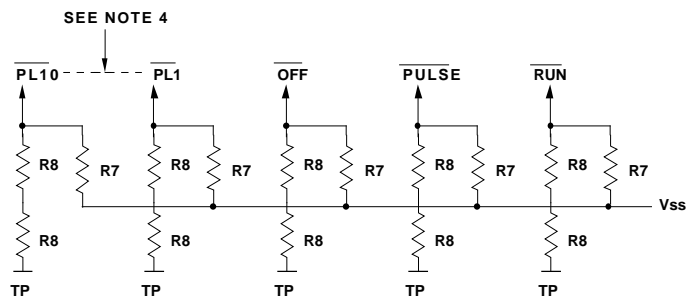

FIGURE 4C. TOUCH INTERFACE FOR LS7312, LS7313

C1 = 0.15 μ F, 200V (400V) *
 C2 = See Figure 4 Value Table
 C3 = 0.047 μ F
 C4 = 470pF
 C5 = See Figure 4 Value Table
 C6 = 0.47 μ F, 200V (400V) *
 L = 100 μ H (200 μ H)*

R1 = 82
 R2 = 1.5M
 R3 = 10k
 R4 = 560 (See Note 1)
 R5 = 10k
 R6 = 1.8k , 1W (2W) *

R7 = 1M to 5M (Select For Sensitivity)
 R8 = 2.7M (4.7M) *
 R9 = 100
 Z1 = 13V \pm 5%, 1W
 Z2 = 6.2V, 1/4W (See Note 2)
 D1 = 1N4148
 T = Q4004L4 (Q5004L4) * Typical

All resistors 1/4W, all capacitors 25V unless otherwise specified.
 * Indicates component change for 220VAC Mains.

MAXIMUM RATINGS:

PARAMETER	SYMBOL	VALUE	UNIT
Storage Temperature	TSTG	-65 to +150	°C
Operating Temperature	TA	0 to +80	°C
DC Supply Voltage	V _{SS} - V _{DD}	+20	V
Any Input Voltage	V _{IN}	V _{SS} - 20 to V _{SS} + 0.5	V

DC ELECTRICAL CHARACTERISTICS:

(TA = 25°C, all voltages referenced to VDD)

	SYMBOL	MIN	TYP	MAX	UNIT	CONDITION
Supply Voltage	V _{SS}	+10	+12	+14	V	-
Supply Current	I _{DD}	-	1.2	2	mA	V _{SS} = 12V, outputs off
Input Voltage:						
SYNC , LO	V _{ISL}	0	-	1/3V _{SS}	V	-
SYNC , HI	V _{ISH}	2/3V _{SS}	-	V _{SS}	V	-
All other inputs, LO	V _{IL}	0	-	1/4V _{SS}	V	-
All other inputs, HI	V _{IH}	1/2V _{SS}	-	V _{SS}	V	-
Input Current:						
SYNC Input	I _H	-	-	110	µA	With Series 1.5M Resistor to 115VAC
Input Pull-up Resistance:						
For LS7310, LS7311						
PL, OFF, RUN, PULSE	R _{IN}	50	100	200	k	-
Output Voltage:						
TRIG , HI	V _{OH}	V _{SS}	-	-	V	-
TRIG , LO	V _{OL}	-	V _{SS} - 8	-	V	-
Output Current:						
TRIG , Sink	I _{OS}	25	-	-	mA	V _{SS} = +12V V _{OL} = V _{SS} - 4V
PL Source	I _{OPL}	5	-	-	mA	V _{OPL} = V _{SS} - 1V

DYNAMIC CHARACTERISTICS:

	SYMBOL	MIN	TYP	MAX	UNIT	CONDITION
SYNC frequency	f _s	40	-	70	Hz	-
PL, RUN, PULSE, OFF hold time	T _H	50	-	infinite	ms	60Hz SYNC
	T _H	60	-	infinite	ms	50Hz SYNC
TRIG Pulse Width (LS7310, LS7312)	T _w	-	33	-	µs	60Hz SYNC
	T _w	-	39	-	µs	50Hz SYNC
TRIG Pulse Width (LS7311, LS7313)	T _w	-	1.0	-	ms	60Hz SYNC
	T _w	-	1.2	-	ms	50Hz SYNC

The information included herein is believed to be accurate and reliable. However, LSI Computer Systems, Inc. assumes no responsibilities for inaccuracies, nor for any infringements of patent rights of others which may result from its use.