

# 1 Bit, 10 dB, GaAs Digital Atten

## 0.02 - 2 GHz

uator  
AT-358

### Features

- CMOS Control Interface
- Low Power Consumption

### Guaranteed Specifications<sup>1</sup> (From -55°C to +85°C)

Frequency Range	0.02 – 2.0 GHz	
Nominal Attenuation <sup>2</sup>	10 dB	
Attenuation Accuracy	0.02 – 2.0 GHz	+/-0.5 dB Max
	0.02 – 1.0 GHz	+/-0.3 dB Max
	0.02 – 0.5 GHz	+/-0.2 dB Max
	0.02 – 0.2 GHz	+/-0.2 dB Max
VSWR	0.02 – 2.0 GHz	1.9:1 Max
	0.02 – 1.0 GHz	1.3:1 Max
	0.02 – 0.5 GHz	1.3:1 Max
	0.02 – 0.2 GHz	1.3:1 Max
Reference Insertion Loss	0.02 – 2.0 GHz	2.7 dB Max
	0.02 – 1.0 GHz	1.0 dB Max
	0.02 – 0.5 GHz	0.9 dB Max
	0.02 – 0.2 GHz	0.8 dB Max

### Operating Characteristics

Impedance	50 Ohms Nominal		
Switching Characteristics			
Ton, Toff (50% CTL to 90%/10% RF)	100 ns Typ		
Trise, Tfall (10%/90% or 90%/10% RF)	40 ns Typ		
Switching Transients (Unfiltered)	50 mV Typ		
Input Power for 1 dB Compression			
0.5 – 2.0 GHz	+24 dBm Typ		
0.05 GHz	+18 dBm Typ		
Intermodulation Intercept Point (for two-tone input power up to +5 dBm)			
Intercept Points	IP2	IP3	
0.5 – 2.0 GHz	+58	+38	dBm Typ
0.05 GHz	+54	+35	dBm Typ
Bias Power	+5 VDC @ 1 mA Max		
Control Voltages			
Vin Low (0)	0.0 to 1.5V @ 1µA Max		
Vin High (1)	3.5 to 5.0V @ 1µA Max		

1. All specifications apply with 50 ohm impedance connected to all RF ports, with +5 VDC bias voltage.
2. Above reference insertion loss.
3. Contact the factory for standard or custom screening requirements.

### Ordering Information

Model No.	Package
AT-358 PIN	TO-8-2

### TO-8-2

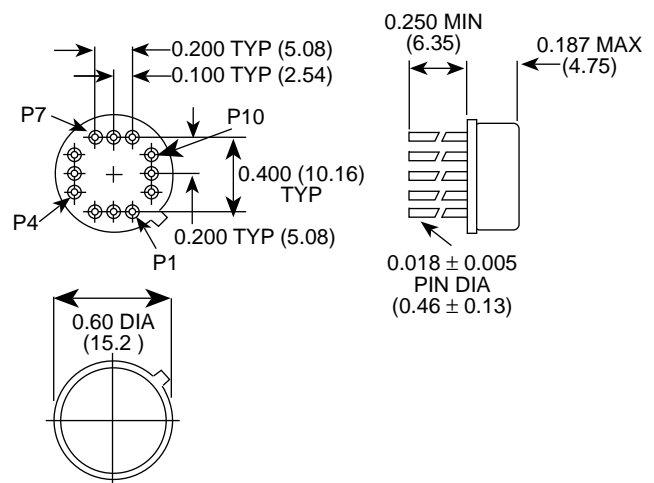

Bottom of Case is AC Ground  
Dimensions in ( ) are in mm.

Unless Otherwise Noted: .xxx = ± 0.010 (.xx = ± 0.25)  
.xx = ± 0.02 (.x = ± 0.5)

### Functional Schematic (Top View)

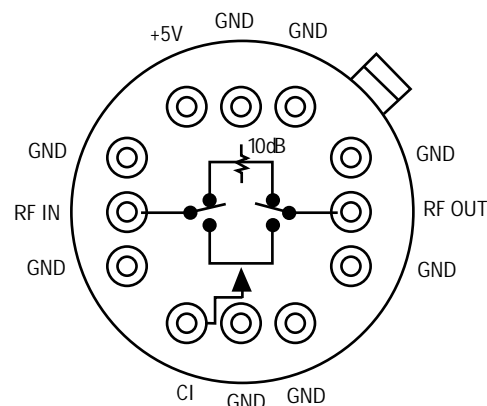

### Truth Table

C1	State
0	Reference Loss
1	Attenuation

**Absolute Maximum Ratings**

Parameter	Absolute Maximum <sup>1</sup>
Max. Input Power	
0.05 GHz	+27 dBm
0.5 – 2.0 GHz	+32 dBm
Bias Voltage	0.5 to +7 V
Control Voltage	-0.5 to V bias + 0.5 V
Operating Temperature	-55°C to +125°C
Storage Temperature	-65°C to +150°C

1. Operation of this device above any one of these parameters may cause permanent damage.

**Typical Performance**

