

# Digital Attenuator, 31 dB, 5-Bit, TTL Driver DC - 2.0 GHz

**AT15-0001**

V4.00

## Features

- Attenuation: 1-dB Steps to 31 dB
- Low DC Power Consumption
- Integral TTL Driver
- 50Ω Nominal Impedance

## Description

M/A-COM's AT15-0001 is a GaAs FET 5-bit digital attenuator with a 1-dB minimum step size and 31 dB total attenuation. This attenuator and integral TTL driver is in a 24-pin dual inline package. The AT15-0001 is ideally suited for use where accuracy, fast switching, very low power consumption and low intermodulation products are required. Typical applications include dynamic range setting in precision receiver circuits and other gain/leveling control circuits.

Environmental screening is available. Contact the factory for information.

## DI-3

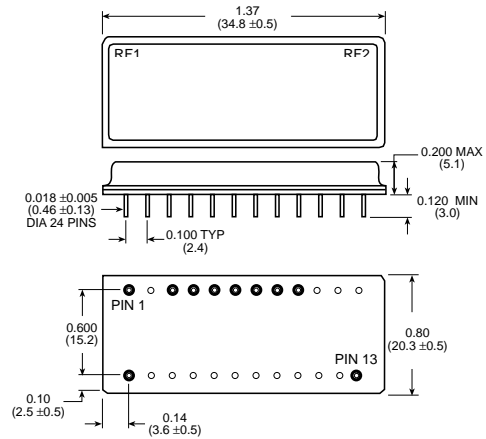

### Pin Configuration

1	2	3	4	5	6	7	8	9	10-12	13	14-23	24
+5 V	GND	-12 V	GND	C16	C1	C2	C4	C8	GND	RF2	GND	RF1

## Typical Electrical Specifications<sup>1</sup>, T<sub>A</sub> = -55°C to +85°C

Parameter	Test Conditions	Units	Minimum	Typical	Maximum
Reference Insertion Loss	DC - 0.5 GHz	dB			6.0
	DC - 1.0 GHz	dB			6.5
	DC - 2.0 GHz	dB			7.3
Attenuation Accuracy <sup>2,3</sup>	Any Single Bit	DC - 1.0 GHz	± (0.2 dB + 2% of attenuation setting in dB) dB		
	Any Combination of Bits	DC - 2.0 GHz	± (0.25 dB + 2% of attenuation setting in dB) dB		
		DC - 1.0 GHz	± (0.2 dB + 2% of attenuation setting in dB) dB		
		DC - 2.0 GHz	± (0.3 dB + 2% of attenuation setting in dB) dB		
VSWR	DC - 0.5 GHz				1.3:1
	DC - 1.0 GHz				1.4:1
	DC - 2.0 GHz				1.7:1
Trise, Tfall Ton, Toff Transients	10% RF to 90% RF	nS		5	
	50% Control to 90%/10% RF	nS		30	
	In-band	mV		220	
1 dB Compression	Input Power	0.05 GHz	dBm	+20	
	Input Power	0.5 - 2.0 GHz	dBm	+27	
Input IP <sub>3</sub>	For two-tone input power up to +5 dBm	0.05 GHz	dBm	+40	
		0.5 - 2.0 GHz	dBm	+40	
Input IP <sub>2</sub>	For two-tone input power up to +5 dBm	0.05 GHz	dBm	+60	
		0.5 - 2.0 GHz	dBm	+75	
V <sub>CC</sub>		V	4.5	5.0	5.5
V <sub>EE</sub>		V	-16.5		-10.8
I <sub>CC</sub>	V <sub>CC</sub> = 4.5 to 5.5 V Vctl = 0 to 0.8 V, or V <sub>CC</sub> - 2.1 V to V <sub>CC</sub>	mA			10
I <sub>EE</sub>	V <sub>EE</sub> = -16.5 to -10.8 V	mA			8.0
	V <sub>EE</sub> = -12.0 V	mA			5.0
Vctl	Logic 0 (TTL)	V	0.0		0.8
	Logic 1 (TTL)	V	2.0		5.0
Input Leakage Current	Low	0 to 0.8 V	μA		1.0
	High	2.0 to 5.0 V	μA		1.0

1. All specifications apply when operated with bias voltages of +5 V for V<sub>CC</sub> and -16.5 V to -10.8 V for V<sub>EE</sub>, and 50Ω impedance at all ports unless otherwise specified.
2. Above reference insertion loss.
3. This attenuator is guaranteed monotonic.
4. Replaces AT-104.

Specifications Subject to Change Without Notice.

**M/A-COM, Inc.**

1

North America: Tel. (800) 366-2266  
Fax (800) 618-8883

■ Asia/Pacific: Tel. +81 (03) 3226-1671  
Fax +81 (03) 3226-1451

■ Europe: Tel. +44 (1344) 869 595  
Fax +44 (1344) 300 020

**Absolute Maximum Ratings<sup>1</sup>**

Parameter	Absolute Maximum
Maximum Input Power	
DC - 0.5 GHz	+27 dBm
0.5 - 2.0 GHz	+34 dBm
Supply Voltages	
V <sub>CC</sub>	-0.5 V to +7.0 V
V <sub>EE</sub>	-18 V to +0.5 V
Control Voltage	-0.5 V to V <sub>CC</sub> + 0.5 V
Operating Temperature	-55°C to +125°C
Storage Temperature	-65°C to +150°C

1. Operation of this device above any one of these parameters may cause permanent damage.

**Functional Schematic**

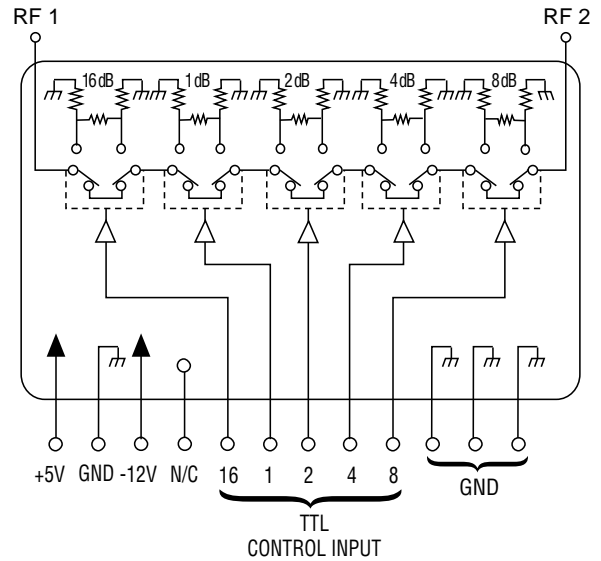

**Truth Table**

Control Inputs					Attenuation
C16	C8	C4	C2	C1	
0	0	0	0	0	Reference
0	0	0	0	1	1 dB
0	0	0	1	0	2 dB
0	0	1	0	0	4 dB
0	1	0	0	0	8 dB
1	0	0	0	0	16 dB
1	1	1	1	1	31 dB

0 = TTL Low  
1 = TTL High

**Ordering Information<sup>2</sup>**

Part Number	Package
AT15-0001	Dual Inline

2. Contact the factory for standard or custom screening requirements.

**Typical Performance**

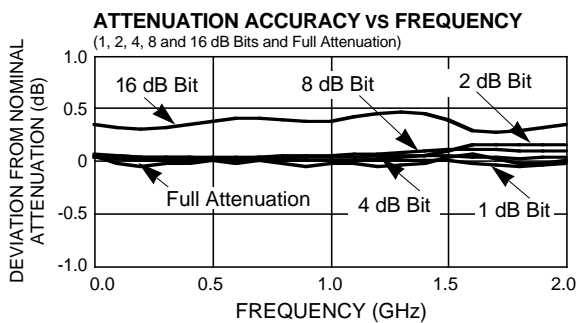
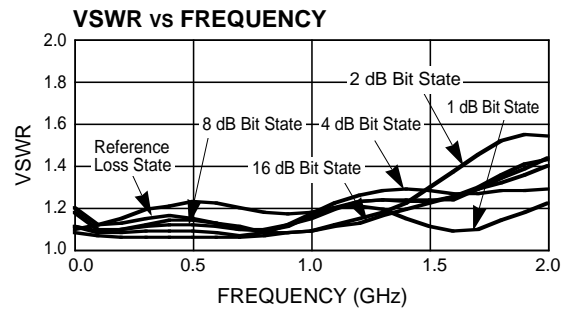
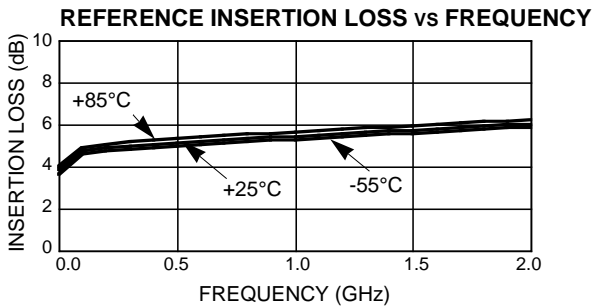

Specifications Subject to Change Without Notice.