

# RF MOSFET Power Transistor, 30W, 12V

## 2 - 175 MHz

# DU1230S

V2.00

### Features

- N-Channel Enhancement Mode Device
- DMOS Structure
- Lower Capacitances for Broadband Operation
- High Saturated Output Power
- Lower Noise Figure Than Bipolar Devices
- Specifically Designed for 12 Volt Applications

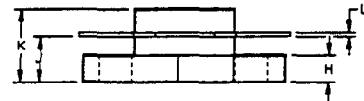
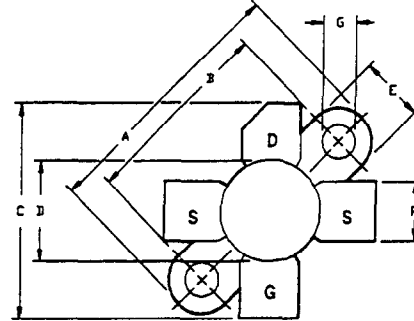

### Absolute Maximum Ratings at 25°C

Parameter	Symbol	Rating	Units
Drain-Source Voltage	$V_{DS}$	40	V
Gate-Source Voltage	$V_{GS}$	20	V
Drain-Source Current	$I_{DS}$	8	A
Power Dissipation	$P_D$	175	W
Junction Temperature	$T_J$	200	°C
Storage Temperature	$T_{STG}$	-55 to +150	°C
Thermal Resistance	$\theta_{JC}$	1	°C/W

LETTER DIM	MILLIMETERS		INCHES	
	MIN	MAX	MIN	MAX
A	24.64	24.89	.970	.980
B	18.29	18.54	.720	.730
C	20.07	20.83	.790	.820
D	9.47	9.73	.373	.383
E	6.22	6.48	.245	.255
F	5.64	5.79	.222	.228
G	2.92	3.30	.115	.130
H	2.29	2.67	.090	.105
J	4.04	4.55	.159	.179
K	6.58	7.39	.259	.291
L	.10	.15	.004	.006

### Electrical Characteristics at 25°C

Parameter	Symbol	Min	Max	Units	Test Conditions
Drain-Source Breakdown Voltage	$BV_{DSS}$	40	-	V	$V_{GS}=0.0\text{ V}, I_{DS}=10.0\text{ mA}$
Drain-Source Leakage Current	$I_{DSS}$	-	2.0	mA	$V_{DS}=15.0\text{ V}, V_{GS}=0.0\text{ V}$
Gate-Source Leakage Current	$I_{GSS}$	-	2.0	$\mu\text{A}$	$V_{GS}=20.0\text{ V}, V_{DS}=0.0\text{ V}$
Gate Threshold Voltage	$V_{GS(TH)}$	2.0	6.0	V	$V_{DS}=10.0\text{ V}, I_{DS}=200\text{ mA}$
Forward Transconductance	$G_M$	1.0	-	S	$V_{DS}=10.0\text{ V}, I_{DS}=2000\text{ mA}, \Delta V_{GS}=1.0\text{ V}$
Input Capacitance	$C_{ISS}$	-	100	pF	$V_{DS}=12.0\text{ V}, F=1.0\text{ MHz}$
Output Capacitance	$C_{OSS}$	-	120	pF	$V_{DS}=12.0\text{ V}, F=1.0\text{ MHz}$
Reverse Capacitance	$C_{RSS}$	-	24	pF	$V_{DS}=12.0\text{ V}, F=1.0\text{ MHz}$
Power Gain	$G_P$	9.0	-	dB	$V_{DD}=12.0\text{ V}, I_{DQ}=200\text{ mA}, P_{OUT}=30\text{ W}, F=175\text{ MHz}$
Drain Efficiency	$\eta_D$	60	-	%	$V_{DD}=12.0\text{ V}, I_{DQ}=200\text{ mA}, P_{OUT}=30\text{ W}, F=175\text{ MHz}$
Load Mismatch Tolerance	VSWR-T	-	30:1	-	$V_{DD}=12.0\text{ V}, I_{DQ}=200\text{ mA}, P_{OUT}=30\text{ W}, F=175\text{ MHz}$

Specifications Subject to Change Without Notice.

**M/A-COM, Inc.**

North America: Tel. (800) 366-2266  
Fax (800) 618-8883

Asia/Pacific: Tel. +81 (03) 3226-1671  
Fax +81 (03) 3226-1451

Europe: Tel. +44 (1344) 869 595  
Fax +44 (1344) 300 020

Typical Broadband Performance Curves

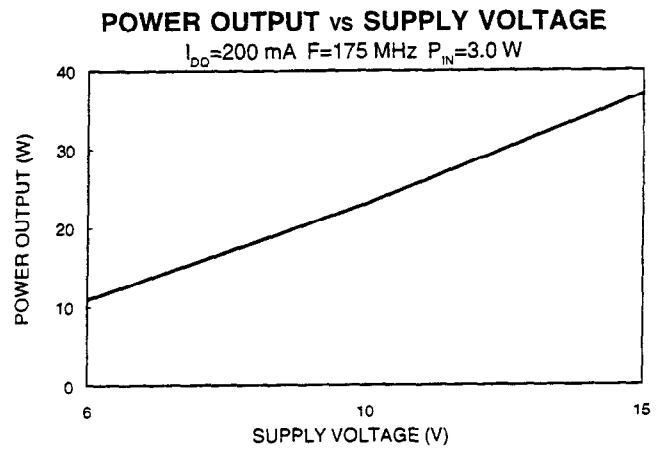
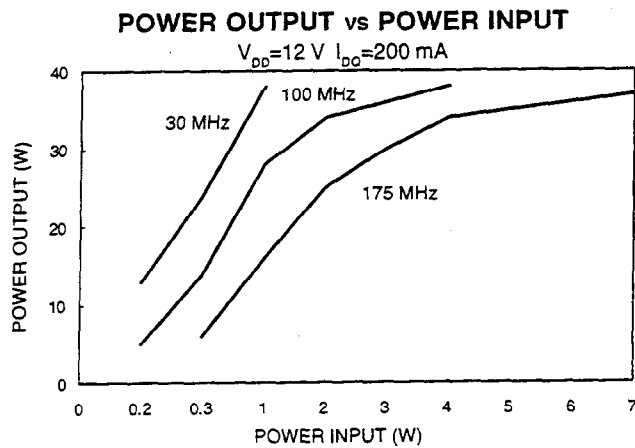
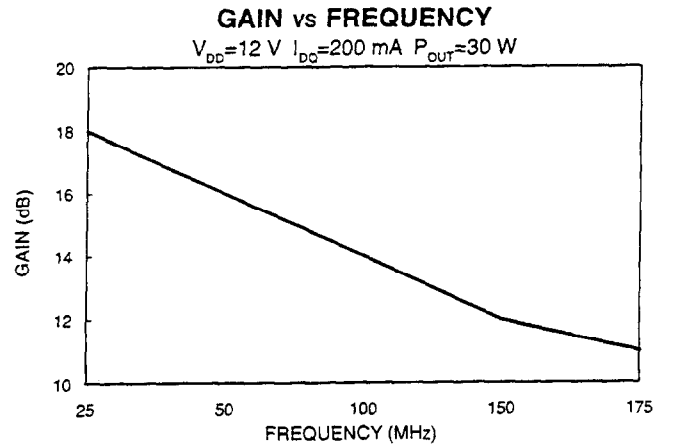
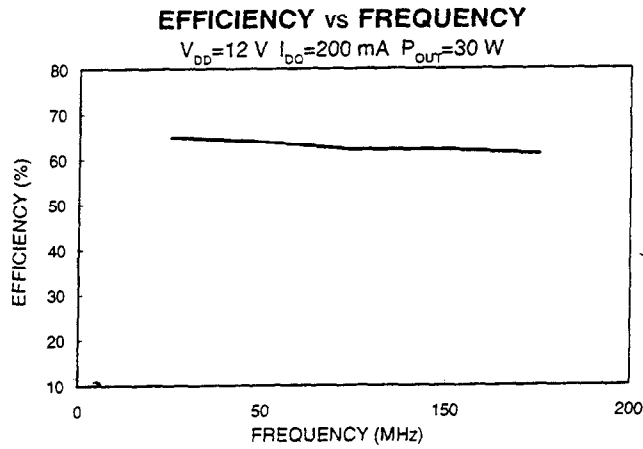

Specifications Subject to Change Without Notice.

**M/A-COM, Inc.**

North America: Tel. (800) 366-2266  
 Fax (800) 618-8883

Asia/Pacific: Tel. +81 (03) 3226-1671  
 Fax +81 (03) 3226-1451

Europe: Tel. +44 (1344) 869 595  
 Fax +44 (1344) 300 020

## Typical Device Impedance

Frequency (MHz)	$Z_{IN}$ (OHMS)	$Z_{LOAD}$ (OHMS)
30	12.0 - j 14.0	2.5 + j 3.0
100	4.0 - j 8.0	2.5 - j 1.0
175	2.0 - j 2.5	2.5 - j 0.5

$$V_{DD}=12\text{ V}, I_{DQ}=200\text{ mA}, P_{OUT}=30\text{ Watts}$$

$Z_{IN}$  is the series equivalent input impedance of the device from gate to source.

$Z_{LOAD}$  is the optimum series equivalent load impedance as measured from drain to ground.

## RF Test Fixture

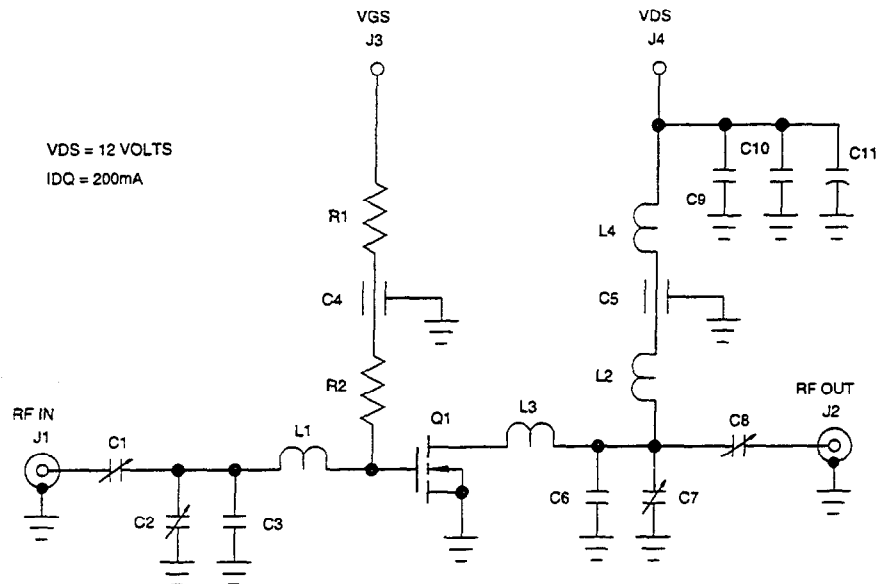

## PARTS LIST

C1,C8	ARCO NO. 462 TRIMMER CAPACITOR 5-80pF
C2,C7	ARCO NO. 422 TRIMMER CAPACITOR 4-40pF
C3	SEMCO CAPACITOR 50pF
C4,C5	FEEDTHROUGH CAPACITOR 0.001uF
C6	SEMCO CAPACITOR 30pF
C9	SEMCO CAPACITOR 1000pF
C10	MONOLITHIC CERAMIC CAPACITOR 0.01uF
C11	ELECTROLYTIC CAPACITOR 50uF 50 V.
L1,L3	NO. 12 AWG COPPER WIRE X 1"
L2	8 TURNS OF NO. 20 AWG ENAMEL WIRE ON '0.25", CLOSE WOUND
L4	12 TURNS OF NO. 20 AWG ON '0.25", CLOSE WOUND
R1,R2	RESISTOR 100K OHMS
Q1	DU1230S
BOARD	FR4 0.062"

Specifications Subject to Change Without Notice.

M/A-COM, Inc.

North America: Tel. (800) 366-2266  
Fax (800) 618-8883

Asia/Pacific: Tel. +81 (03) 3226-1671  
Fax +81 (03) 3226-1451

Europe: Tel. +44 (1344) 869 595  
Fax +44 (1344) 300 020