

Low Noise GaAs MMIC Amplifier

3.5 - 7 GHz

MAAM37000

V 2.00

Features

- 1.8 dB Typical Noise Figure¹
- 16 dB Typical Gain¹
- Single Bias Supply
- DC Decoupled RF Input and Output

Electrical Specifications @ T_A = +25°C

| | | |
|---------------------------------------|---|-------------|
| Frequency Range | 3.5 – 7.0 GHz | |
| Gain ¹ | 17.0 dB Typ | 15.0 dB Min |
| Gain Flatness | ±0.8 dB Typ | |
| Noise Figure ¹ | 1.8 dB Typ | 2.8 dB Max |
| VSWR | Input | 1.5:1 Typ |
| | Output | 1.5:1 Typ |
| Output Power at 1 dB Gain Compression | +14 dBm Typ | |
| Third Order Intercept | +24 dBm Typ | |
| Reverse Isolation | 35 dB Typ | |
| Impedance | 50 Ω Typ | |
| Bias Voltage | V _{DD} = +4 Vdc | |
| Bias Current | I _{DD} = 75 mA Typ, 100 mA Max | |

Maximum Ratings

| | |
|-----------------------|-----------------|
| Voltage | +7 Volts |
| Input Power | +20 dBm |
| Storage Temperature | -65°C to +150°C |
| Operating Temperature | -55°C to +125°C |

1. 100% on-wafer tested.

Schematic

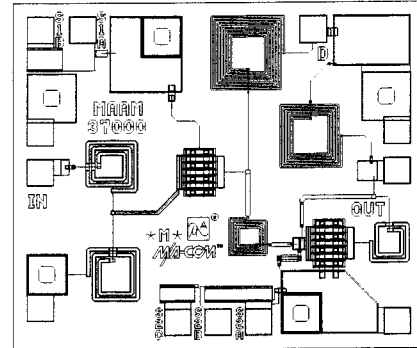
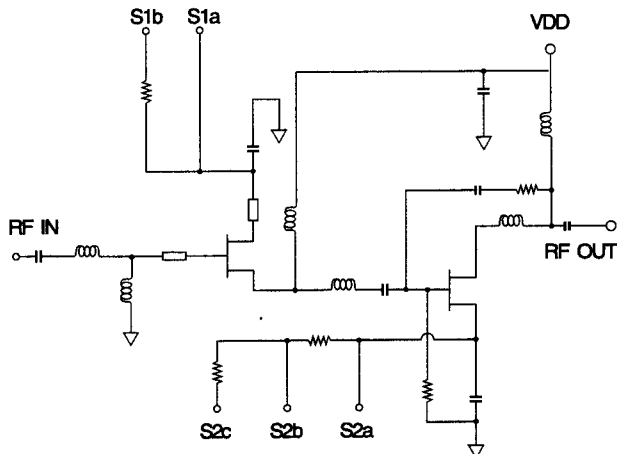

Typical Performance

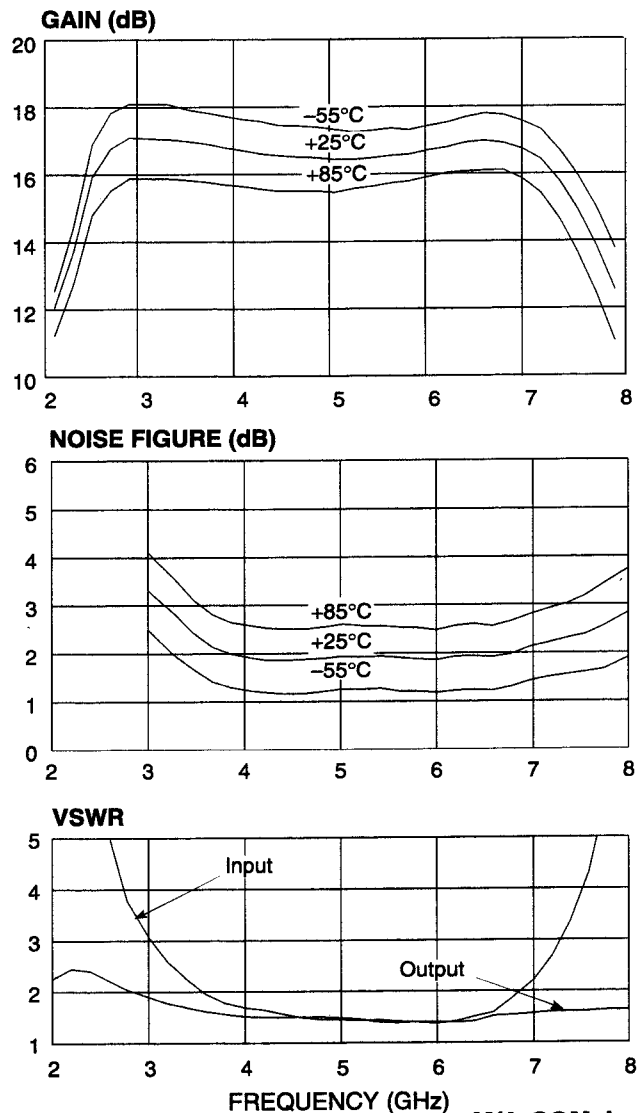

Specifications Subject to Change Without Notice.

11-58

M/A-COM, Inc.

Handling

Permanent damage to the MAAM37000 may occur if the following precautions are not adhered to:

- A. Cleanliness — The MAAM37000 should be handled in a clean environment. DO NOT attempt to clean assembly after the MAAM37000 is installed.
- B. Static Sensitivity — All die handling equipment and personnel should comply with DOD-STD-1686 Class I.
- C. Transients — Avoid instrument and power supply transients while bias is connected to the MAAM37000. Use shielded signal and bias cables to minimize inductive pick-up.
- D. General Handling — DO NOT touch the surface of the die. It is recommended that the MAAM37000 die be handled along the long side with a sharp pair of tweezers.

Mounting

The MAAM37000 is back-metallized with Pd/Ni/Au(100/1,000/30,000Å) metallization. It can be die-mounted using Au/Sn eutectic preforms or a thermally and electrically conductive epoxy. The attachment surface should be clean and flat.

Eutectic Die Attach:

- A. An 80/20 Au/Sn preform is recommended with a work surface temperature of approximately 255°C and a tool temperature of 265°C. When hot 95/5 nitrogen/hydrogen gas is applied, solder temperature should be approximately 290°C.
- B. DO NOT expose the MAAM37000 to a temperature greater than 320°C for more than 20 seconds. No more than 3 seconds of scrubbing should be required for attachment.

Epoxy Die Attach:

- A. Electrically conductive epoxy is required.
- B. Apply a minimum amount of epoxy and place the MAAM37000 into position. A thin epoxy fillet should be visible around the perimeter of the die.
- C. Cure epoxy per manufacturer's recommended schedule.

Bonding

- A. Ball or wedge bond with 1.0 mil diameter gold wire or 3.0 mil x 0.5 mil ribbon. Thermosonic bonding with a nominal stage temperature of 150°C and a ball bonding force of 40 to 50 grams or wedge bonding force of 18 to 22 grams is recommended. Ultrasonic energy and time should be adjusted to the minimum levels necessary to achieve reliable bonds.
- B. Bonds should be started on the die and terminated on the package.
- C. Bonding pads are 4.0 x 4.0 mils.

Outline

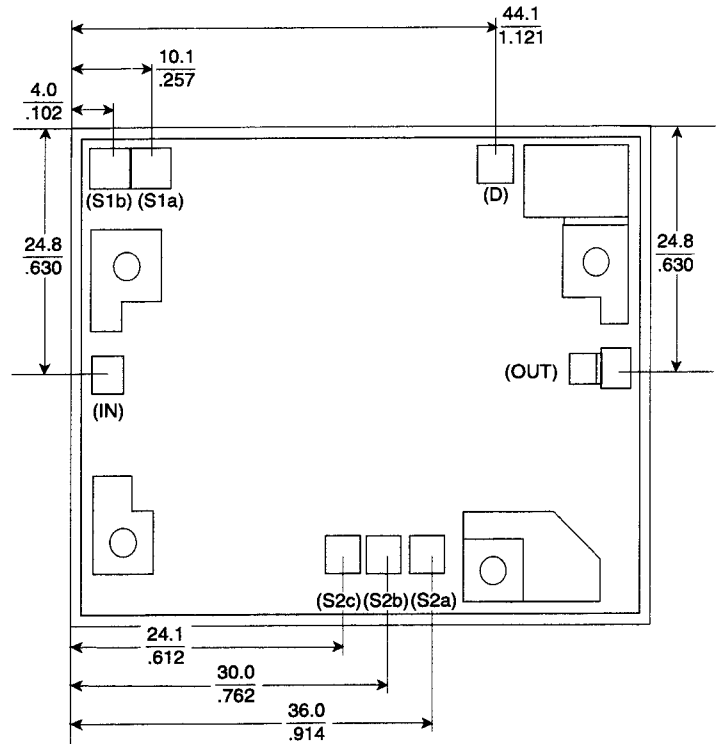

All dimensions are ^{mils}/_{mm}.

Die Size

0.060" X 0.051" X 0.004"
(1.529mm X 1.290mm X 0.0102mm)

Typical Bias Configuration

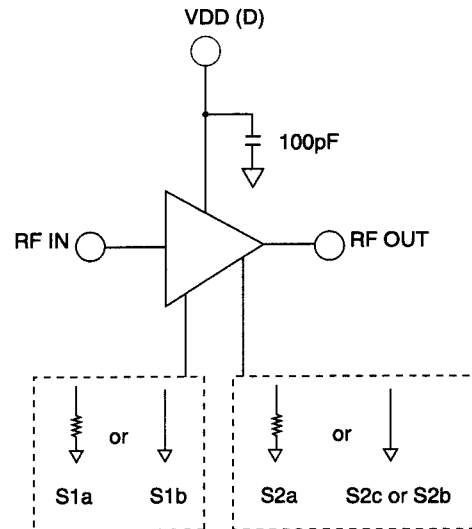

1. Nominal bias is obtained with on-chip resistors by grounding pads S1b and S2b.
2. Ground pads S1b and S2c for lower second stage current.
3. Optional biasing can be obtained with off-chip resistors bonded from pads S1a and S2a to ground. Adjusting the bias can customize performance to suit special requirements.

Specifications Subject to Change Without Notice.

M/A-COM, Inc.

11-59

North America: Tel. (800) 366-2266 ■ Asia/Pacific: Tel. +81 (03) 3226-1671 ■ Europe: Tel. +44 (1344) 869 595
 Fax (800) 618-8883 Fax +81 (03) 3226-1451 Fax +44 (1344) 300 020