

GaAs SPDT Switch DC-4 GHz

SW-226/227/228

V 2.01

Features

- Miniature Ceramic Package
- Terminated (SE-226), High Isolation (SW-227), Low Loss (SW-228)
- Fast Switching Speed, 6 ns Typical
- Ultra Low DC Power Consumption

Guaranteed Specifications *

(From -55°C to +85°C)

Frequency Range		DC-4 GHz			
Model Number	SW-226	SW-227	SW-228		
Insertion Loss	DC-4 GHz	1.5	1.4	1.0	dB Max
	DC-2 GHz	1.2	1.1	0.8	dB Max
	DC-1 GHz	1.0	1.0	0.7	dB Max
	DC-0.5 GHz	0.9	0.9	0.7	dB Max
VSWR	DC-4 GHz	2.3:1	2.0:1	1.9:1	Max
	DC-2 GHz	1.6:1	1.6:1	1.3:1	Max
	DC-1 GHz	1.4:1	1.4:1	1.2:1	Max
	DC-0.5 GHz	1.2:1	1.2:1	1.2:1	Max
Isolation	DC-4 GHz	25	35	22	dB Min
	DC-2 GHz	40	40	32	dB Min
	DC-2 GHz	48	50	42	dB Min
	DC-0.5 GHz	53	55	50	dB Min

Operating Characteristics

Impedance 50 Ohms Nominal

Switching Characteristics†

Trise, Tfall	3 ns Typ
Ton, Toff (50% CTL to 90/10% RF)	6 ns Typ
Transients (In-Band) SW-226/227	30 mV Typ
Transients (In-Band) SW-228	10 mV Typ

Input Power for 1 dB Compression

Control Voltages (Vdc)	0/-5	0/-8	
0.5-4 GHz	+27	+33	dBm Typ
0.05 GHz	+21	+26	dBm Typ

Intermodulation Intercept Point

(for two-tone input power up to +13 dBm)

Intercept Points	IP ₂	IP ₃	
0.5 - 4 GHz	+68	+46	dBm Typ
0.05 GHz	+62	+40	dBm Typ

Control Voltages (Complementary Logic)

V _{IN} Low (SW-226/227/228)	0 to -0.2V @ 20 µA Max
V _{IN} Hi (SW-226/227)	-5V @ 110 µA Typ to -8V @ 600 µA Max
V _{IN} Hi (228)	-5V @ 50 µA Typ to -8V @ 300 µA Max

Environmental

See Appendix for MIL-STD-883 screening option.

* All specifications apply with 50 ohm impedance connected to all RF ports with 0 and -5 VDC control voltages.

† Faster switching speed can be achieved with enhanced driver waveform.

** For the SW-227 and SW-228 only, when an RF output is 'OFF' it is shorted to case ground.

CR-2

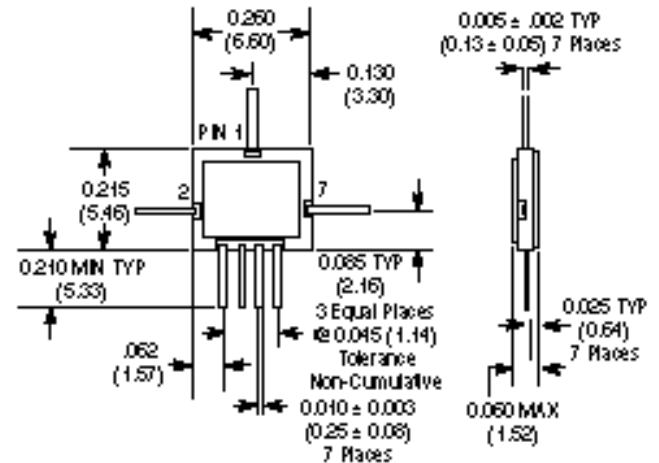

Bottom of Case is AC Ground.

Dimensions in () are in mm.

Unless Otherwise Noted: .xxx = ±0.010 (.xx = ±0.25)

.xx = ±0.02 (.x = ±0.5)

Ordering Information

Model No.	Package
SW-226 PIN	Ceramic
SW-227 PIN	Ceramic
SW-228 PIN	Ceramic

Truth Table**

Control Input				Condition of Switch	
				RF Common To Each RF PORT	
	A1	B1	A2	B2	
SW-226/227	HI	LO	LO	HI	ON
	LO	HI	HI	LO	OFF
SW-228	HI	LO	NC	NC	ON
	LO	HI	NC	NC	OFF

Pin Configuration

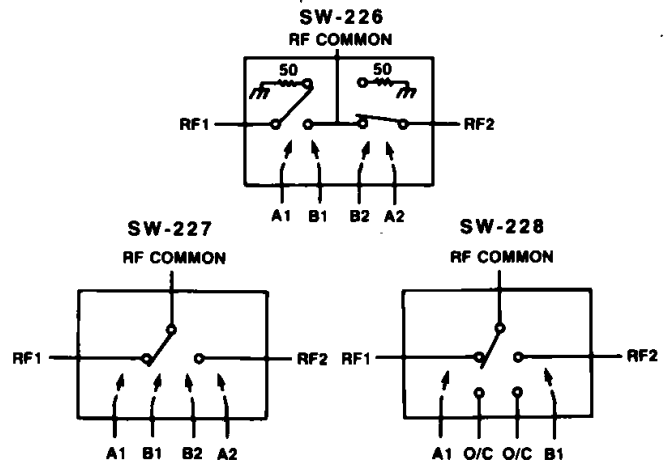

Typical Performance

