



# Cellular CDMA/AMPS Power Amplifier 824 - 849 MHz

## Features

- High Gain 2-stage HBT Amplifier
- Single Supply, 3V Operation
- Dual Mode Operation
- 29 dBm Linear Output Power
- 31.5 dBm CW Output Power
- High Efficiency
- Low Quiescent Current
- Miniature FQFP-N 4mm Plastic Package

## Description

M/A-COM's MAAPSS0006 is a high power, high efficiency linear power amplifier in a miniature FQFP-N 4mm plastic package. The MAAPSS0006 includes a 2-stage amplifier and bias control network. Efficiency of the MAAPSS0006 is optimized for each mode by an on-chip analog control circuit.

The MAAPSS0006 is ideally suited for CDMA and AMPS handset applications where high linearity and low power consumption are important transmitter requirements. The MAAPSS0006 is design to operate with the MD59-0054 Upconverter/Driver IC.

The MAAPSS0003 is fabricated using M/A-COM's *iHBT* HBT process. The process utilizes the InGaP/GaAs materials system for reduced performance variation over temperature, high reliability and improved manufacturability.

## Functional Block Diagram

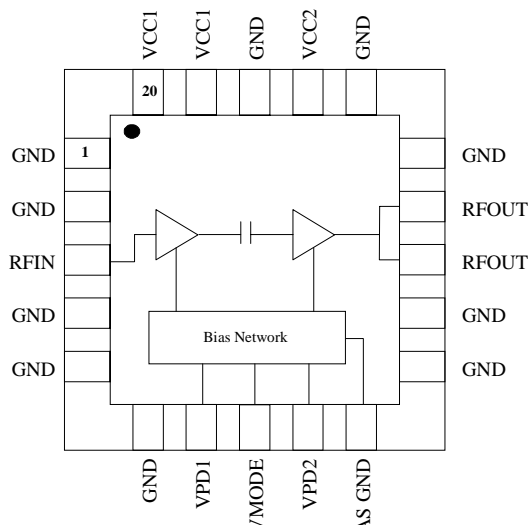

## Ordering Information

Part Number	Package
MAAPSS0006	FQFP-N 4.0mm Plastic Package
MAAPSS0006TR	Forward Tape and Reel <sup>1</sup>
MAAPSS0006RTR	Reverse Tape and Reel <sup>1</sup>

1. If specific reel size is required, consult factory for part number assignment.

## Electrical Specifications: $V_{CC} = 3.4V$ , $V_{ref} = 3.0V$ , $T_A = +25^{\circ}C$

Parameter	Test Conditions	Units	Min.	Typ.	Max.
Frequency Range		MHz	824		849
Small Signal Gain		dB		29	
Linear Gain		dB		29	
Linear Output Power	At maximum ACPR Level	dBm	28	29	
ACPR <sup>1</sup>		dBc			-44
ACPR <sup>2</sup>		dBc			-56
Linear Efficiency	At maximum ACPR Level	%	32	35	
CW Output Power	At maximum ACPR Level	dBm		31.5	
CW Efficiency	At maximum ACPR Level	%		45	

1. Per IS95: ACPR is defined as the ratio of the total power in a 1.228MHz bandwidth to the power within a 30KHz bandwidth measured at  $\pm 885KHz$  offset from the carrier frequency.
2. Per IS95: ACPR is defined as the ratio of the total power in a 1.228MHz bandwidth to the power within a 30KHz bandwidth measured at  $\pm 1.98MHz$  offset from the carrier frequency.

Specifications subject to change without notice.

- North America: Tel. (800) 366-2266, Fax (800) 618-8883
- Asia/Pacific: Tel.+81-44-844-8296, Fax +81-44-844-8298
- Europe: Tel. +44 (1344) 869 595, Fax+44 (1344) 300 020

Visit [www.macom.com](http://www.macom.com) for additional data sheets and product information.

tyco / Electronics

M/A-COM

**Electrical Specifications:  $V_{CC} = 3.4V$ ,  $V_{ref} = 3.0V$ ,  $T_A = +25^{\circ}C$  (Cont'd)**

Parameter	Test Conditions	Units	Min.	Typ.	Max.
Quiescent Current		mA		100	
Noise Power in Rx Band	$P_{OUT} \leq 29$ dBm	dBm/Hz			-120
2 <sup>nd</sup> Harmonic Suppression	$P_{OUT} \leq 29$ dBm	dBc			-30
3 <sup>rd</sup> Harmonic Suppression	$P_{OUT} \leq 29$ dBm	dBc			-40
Input $V_{SWR}$				2:1	
Stability	No oscillations, any phase			5:1	
Output Load Ruggedness $V_{SWR}$	No damage, any phase			10:1	

**PIN Configuration**

PIN #	PIN Name	Description
1	GND	DC and RF Ground
2	GND	DC and RF Ground
3	RFIN	RF input to the amplifier, requires matching network
4	GND	DC and RF Ground
5	GND	DC and RF Ground
6	GND	DC and RF Ground
7	VPD1	1 <sup>st</sup> stage bias control
8	VMODE	High / Low gain selector
9	VPD2	2 <sup>nd</sup> stage bias control
10	BIAS GND	Bias Control Ground, requires RF choke
11	GND	DC and RF Ground
12	GND	DC and RF Ground
13	RF OUT	RF Output of the amplifier, requires matching network
14	RF OUT	RF Output of the amplifier, requires matching network
15	GND	DC and RF Ground
16	GND	DC and RF Ground
17	$V_{CC2}$	Voltage supply for the bias network
18	GND	DC and RF Ground
19	$V_{CC1}$	Voltage supply for 1 <sup>st</sup> stage, requires matching network
20	$V_{CC1}$	Voltage supply for 1 <sup>st</sup> stage, requires matching network

**Block Diagram**

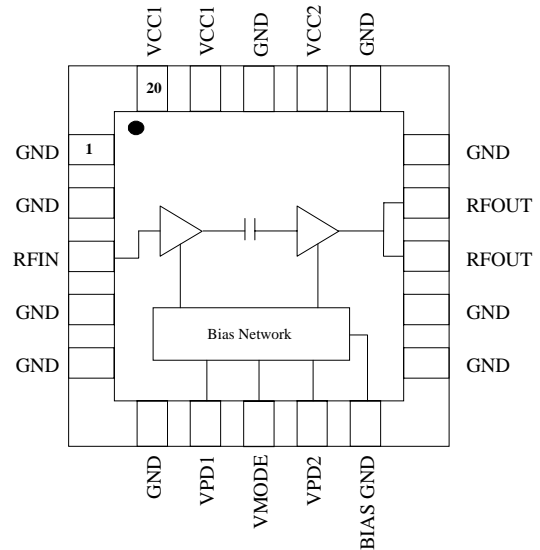

**FQP-N 4mm Package**

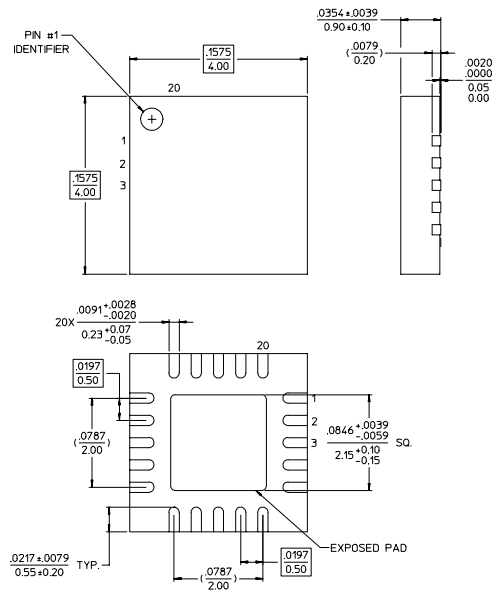

Specifications subject to change without notice.

FQFP-N - 4mm <sup>1</sup>

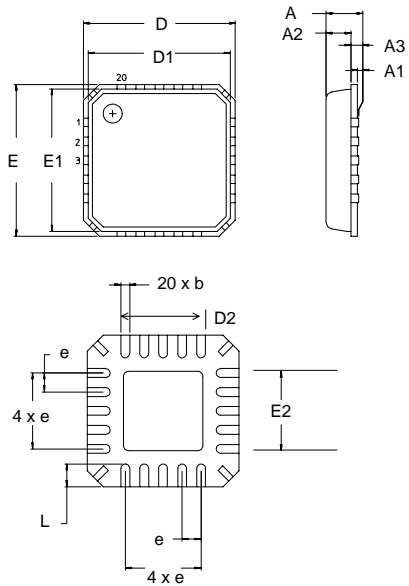

1. See JEDEC MO-220A for additional dimensional and tolerance information.

FQFP-N - 4 mm

Dim.	Measurement (mm)		
	Min.	Nom.	Max.
A	0.80	0.90	1.00
A1	0	0.02	0.05
A2	0	0.65	1.00
A3		0.25 ref.	
b	0.18	0.23	0.30
D		4.00 basic	
D1		3.75 basic	
D2	0.75	1.70	2.25
e		0.50 basic	
E		4.00 basic	
E1		3.75 basic	
E2	0.75	1.70	2.25
L	0.35	0.55	0.75

Specifications subject to change without notice.

■ North America: Tel. (800) 366-2266, Fax (800) 618-8883  
 ■ Asia/Pacific: Tel.+81-44-844-8296, Fax +81-44-844-8298  
 ■ Europe: Tel. +44 (1344) 869 595, Fax+44 (1344) 300 020

Visit [www.macom.com](http://www.macom.com) for additional data sheets and product information.

Sample Board Schematic

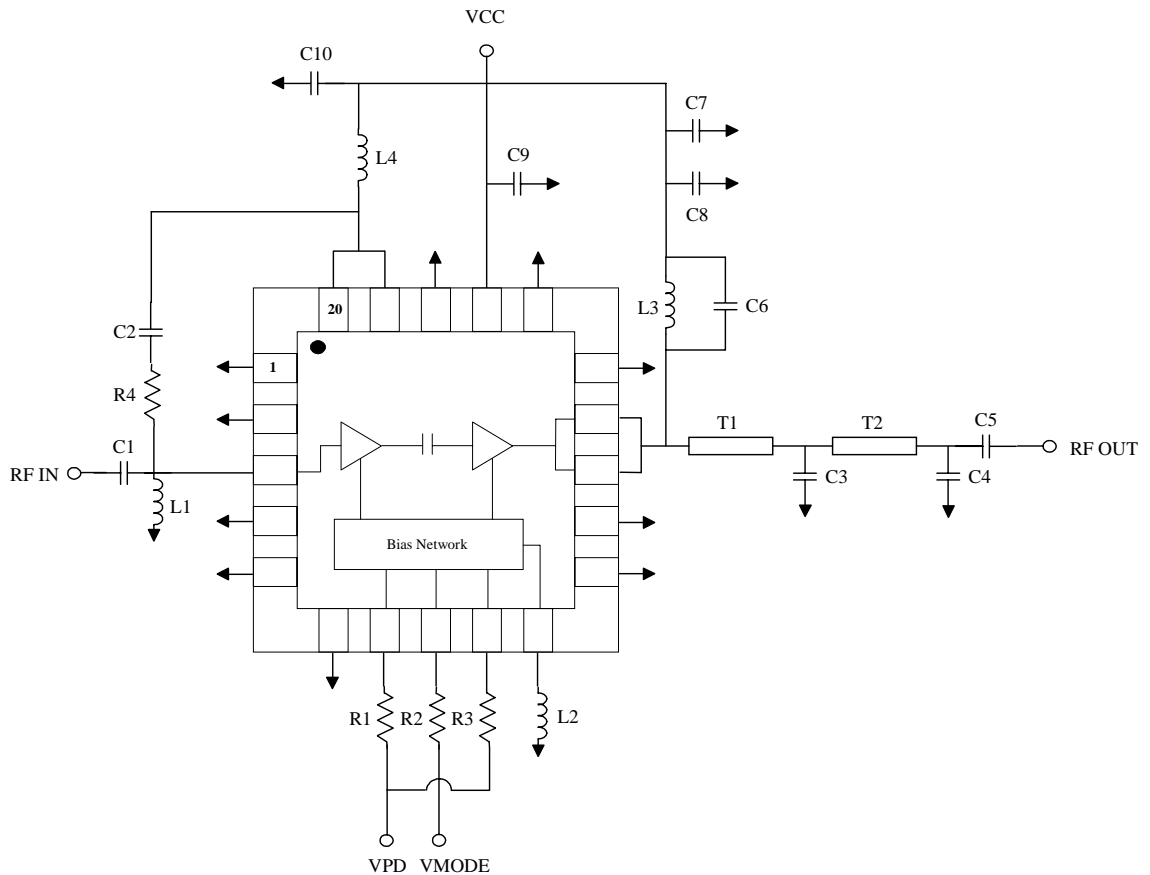

External Circuitry Parts List <sup>1</sup>

Ref. Designation	Value	Purpose
C1, C2	100 pF	DC Block
C3	8.2 pF	RF Matching
C4	4.7 pF	RF Matching
C5	100 pF	DC Block
C6	1.2 pF	RF Matching
C7	10 nF	RF Bypass
C8, C9, C10	100 pF	RF Bypass
L1	6.2 nH	RF Matching
L2	15 nH	Bias Choke
L3	22 nH	RF Choke
L4	2 nH	RF Choke
R1	TBD	Bias Adjust
R2	TBD	Bias Adjust
R3	TBD	Bias Adjust
T1	TBD	RF Matching
T2	TBD	RF Matching

1. Values of external elements not final.

Specifications subject to change without notice.

■ North America: Tel. (800) 366-2266, Fax (800) 618-8883  
 ■ Asia/Pacific: Tel.+81-44-844-8296, Fax +81-44-844-8298  
 ■ Europe: Tel. +44 (1344) 869 595, Fax+44 (1344) 300 020

Visit [www.macom.com](http://www.macom.com) for additional data sheets and product information.