

Low Cost MMIC Mixer, 2.1 – 2.7 GHz

V 1.0

MD54-0007

Features

- MMDS and WLAN Applications
- +18 dBm Input 1 dB Compression Point
- Greater than 20 dB LO to RF Isolation
- +13 dBm LO Drive Level
- No DC Bias Required
- Ultra-Miniature SOT-25 Plastic Package

Description

M/A-COM's MD54-0007 is a passive mixer that achieves the performance of a double balanced diode mixer in an ultra-miniature SOT-25 package. The MD54-0007 is ideally suited for use where high level RF signals and very wide dynamic range are required. Typical applications include frequency up/down conversion, modulation, and demodulation in receivers and transmitters for basestation and portable systems.

The MD54-0007 employs GaAs FETs as mixing elements to achieve a very wide dynamic range in a low cost plastic package. The mixer operates with LO drive levels of +13 dBm to +18 dBm. The LO port may be externally tuned for operation in various frequency bands.

M/A-COM's GaAs IC is fabricated using a mature 0.5 micron gate length GaAs MESFET process. The process features full passivation for increased performance and reliability.

Ordering Information

Part Number	Description
MD54-0007TR	7 inch, 1000 piece reel
MD54-0007TR-3000	13 inch, 3000 piece reel
MD54-0007SMB	Sample Test Board

Functional Schematic

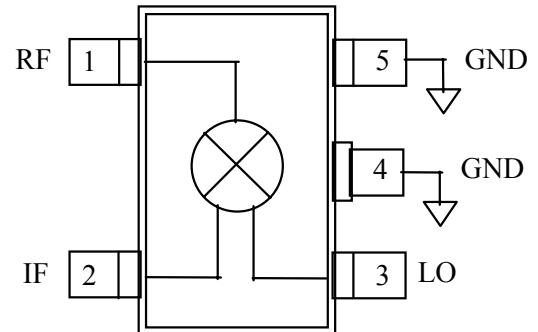

Pin Configuration

Pin	Function	Description
1	RF	RF Input Port
2	IF	IF Output Port
3	LO	LO Input Port
4	GND	Ground
5	GND	Ground

Specifications subject to change without notice.

- **North America:** Tel. (800) 366-2266
- **Asia/Pacific:** Tel. +81-44-844-8296, Fax +81-44-844-8298
- **Europe:** Tel. +44 (1344) 869 595, Fax+44 (1344) 300 020

Visit www.macom.com for additional data sheets and product information.

tyco / Electronics

M/A-COM

Electrical Specifications: $T_A = 25\text{ }^\circ\text{C}$, $Z_0 = 50\ \Omega$ ^{1,2}

Parameter	Test Conditions	Units	Min	Typ	Max
RF Frequency		GHz	2.1		2.7
Conversion Loss		dB		8.0	9.0
Isolation	LO to RF	dB	15	25	
	LO to IF	dB		18	
	RF to IF	dB		18	
VSWR	RF Port			2.0:1	
	LO Port			2.0:1	
	IF Port			2.0:1	
P1dB		dBm		18	
Two-Tone IMR	Two tones each at 0 dBm, tone spacing = 300 KHz, IF = 150 MHz	dBc	45	50	

1. RF signal is 2428 MHz at 0 dBm, LO signal is 2278 MHz at +13 dBm and IF signal is 150 MHz unless otherwise specified.
2. With external LO port matching. See application schematic.

Absolute Maximum Ratings^{1,2}

Parameter	Absolute Maximum
Max RF Input Power	+27 dBm
Max LO Drive Level	+27 dBm
Operating Temperature	-40°C to +85°C
Channel Temperature	+150°C
Storage Temperature	-40°C to +150°C

1. Exceeding any one or combination of these limits may cause permanent damage.
2. Ambient Temperature, +25°C.

Application Information

Static Sensitivity

Gallium arsenide integrated circuits are ESD sensitive and can be damaged by static electricity. Use proper ESD precautions when handling these devices.

Specifications subject to change without notice.

- North America: Tel. (800) 366-2266
- Asia/Pacific: Tel.+81-44-844-8296, Fax +81-44-844-8298
- Europe: Tel. +44 (1344) 869 595, Fax+44 (1344) 300 020

Visit www.macom.com for additional data sheets and product information.



Application Schematic

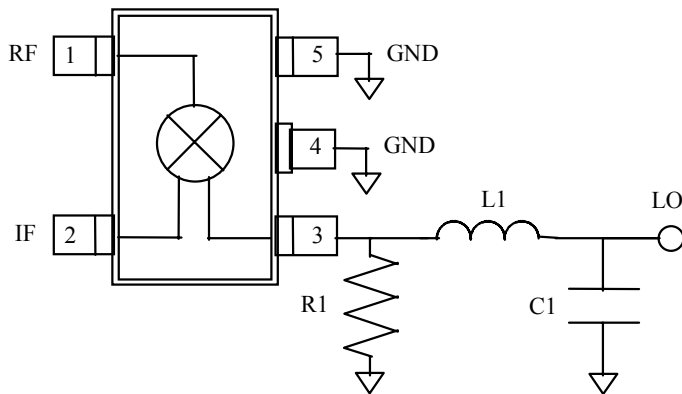

External Circuitry Parts List

Part	LO = 2278 MHz
R1	1.0 KΩ
L1	2.7 nH
C1	2.2 pF

All off-chip components are low-cost surface mount components obtainable from multiple sources. (.060 in. x .030 in. or .080 in. x .050 in.)

SOT-25 Package

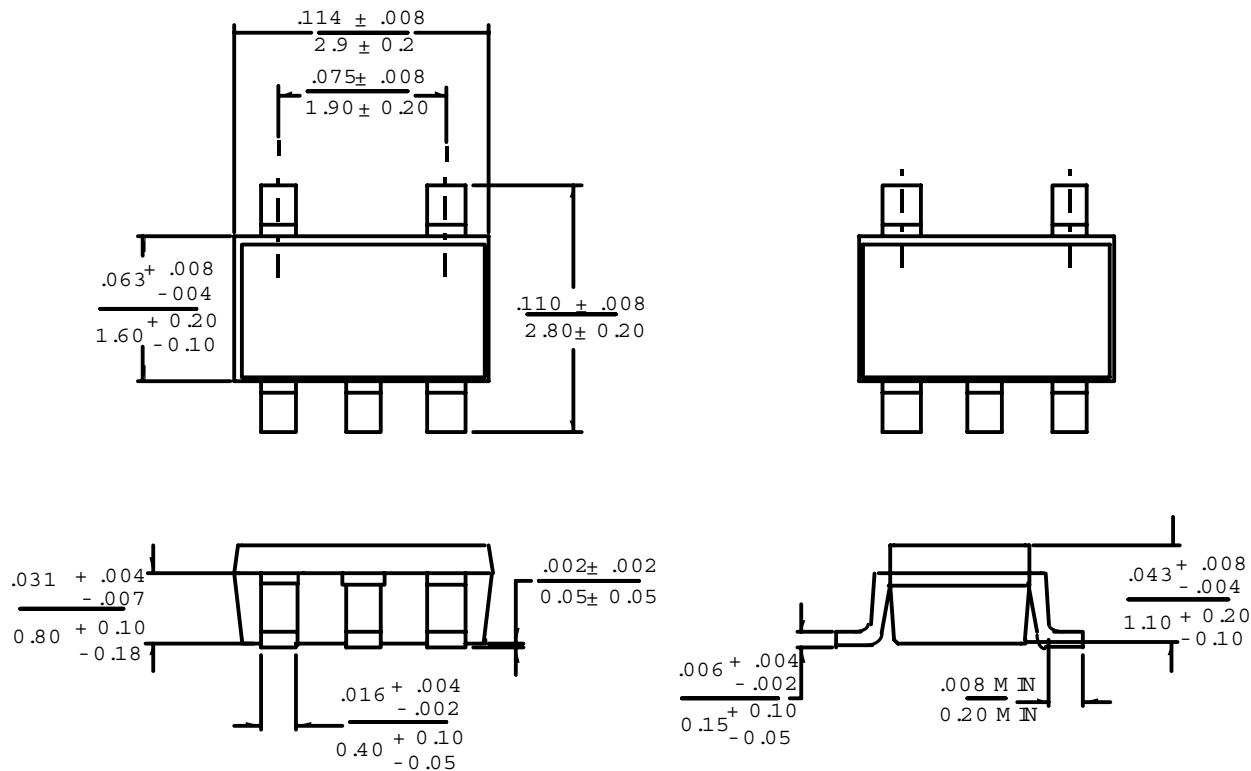

Specifications subject to change without notice.

- North America: Tel. (800) 366-2266
- Asia/Pacific: Tel.+81-44-844-8296, Fax +81-44-844-8298
- Europe: Tel. +44 (1344) 869 595, Fax+44 (1344) 300 020

Visit www.macom.com for additional data sheets and product information.

