



Digital Attenuator, 50 dB, 6-Bit, TTL Driver, DC - 2 GHz

V 5.00

AT20-0106

Features

- Attenuation: 1 dB steps to 50 dB
- Temperature Stability: ± 0.18 dB from -40°C to $+85^{\circ}\text{C}$ Typical
- Low DC Power Consumption
- Surface Mount Package
- Integral TTL Driver
- High Intercept Point
- Low Cost/High Performance
- 50 Ohm Nominal Impedance

Description

M/A-COM's AT20-0106 is a GaAs FET 6-bit digital attenuator with a 1 dB minimum step size and 50 dB total attenuation. This attenuator and integral TTL driver is in a ceramic 24-lead surface mount package. The AT20-0106 is ideally suited for use where accuracy, fast switching, low power consumption and low intermodulation products are required. Typical applications include dynamic range setting in precision receiver circuits and other gain/leveling control circuits. Available with enhanced performance as fully hermetic version. Environmentally screenable as P/N AT-106.

Electrical Specifications: $T_A = 25^{\circ}\text{C}^1$

Parameter	Test Conditions	Frequency	Units	Min	Typ	Max
Reference Insertion Loss	—	DC - 0.5 GHz DC - 1.0 GHz DC - 2.0 GHz	dB dB dB	— — —	3.0 3.5 4.0	3.6 4.1 4.6
Attenuation Accuracy ²	Any Single Bit Any Combination of Bits (For attenuation to 26 dB) Any Combination of Bits (For attenuation 27 to 50 dB)	DC - 2.0 GHz DC - 2.0 GHz DC - 1.5 GHz	dB dB dB	$\pm (0.3 + 4\%$ of atten. setting) $\pm (0.4 + 4\%$ of atten. setting) $\pm (0.5 + 5\%$ of atten. setting)		
VSWR	—	0.05 - 0.10 GHz 0.101 - 2.0 GHz	Ratio Ratio	— —	— —	2.0:1 1.8:1
Trise, Tfall	10% to 90%	—	ns	—	—	50
Ton, Toff	50% Control to 90/10% RF	—	ns	—	—	150
Transients	In-Band (peak-peak)	—	mV	—	50	—
1 dB Compression	Input Power Input Power	0.05 GHz 0.5 - 2.0 GHz	dBm dBm	— —	+20 +28	— —
Input IP3	For two-tone Input Power Up to +5 dBm	0.05 GHz 0.5 - 2.0 GHz	dBm dBm	— —	+34 +46	— —
Input IP2	For two-tone Input Power Up to +5 dBm	0.05 GHz 0.5 - 2.0 GHz	dBm dBm	— —	+75 +79	— —
Vcc	—	—	V	4.5	5.0	5.5
Vee	—	—	V	-8.0	—	-5.0

1. All specifications apply when operated with bias voltages of +5V for Vcc and -5.0V for Vee.
2. This attenuator is guaranteed monotonic.

CR-13

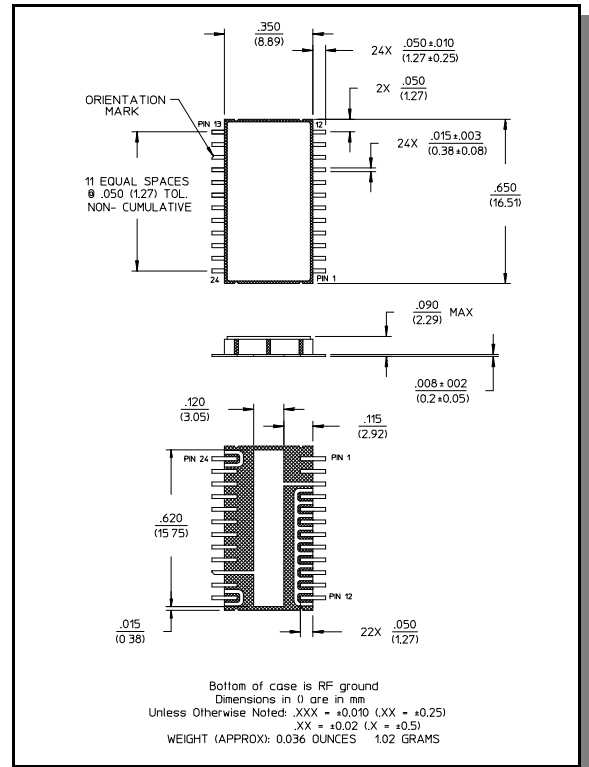

Electrical Specifications: $T_A = 25^\circ\text{C}$

Parameter	Test Conditions	Frequency	Units	Min	Typ	Max
I_{cc}	$V_{cc} = 4.5$ to 5.5V $V_{ctl} = 0$ to 0.8V , or $V_{cc} - 2.1\text{V}$ to V_{cc}	—	mA	—	—	6.0
I_{ee}	$V_{ee} = -5.0$ to -8.0V	—	mA	—	—	1.0

Absolute Maximum Ratings ³

Parameter	Absolute Maximum
Max Input Power 0.5 GHz 0.5 - 2.0 GHz	+27 dBm +34 dBm
Supply Voltages V_{cc} V_{ee}	+5.5V -8.5V
Control Voltage ⁴	-0.5V to $V_{cc} + 0.5\text{V}$
Operating Temperature	-40°C to +125°C
Storage Temperature	-65°C to +150°C

- Operation of this device above any one of these parameters may cause permanent damage.
- Standard CMOS TTL interface, latch-up will occur if logic signal is applied prior to power supply.

Truth Table

Control Inputs						
C6	C5	C4	C3	C2	C1	Attenuation
0	0	0	0	0	0	Reference
0	0	0	0	0	1	1 dB
0	0	0	0	1	0	2 dB
0	0	0	1	0	0	4 dB
0	0	1	0	0	0	8 dB
0	1	0	0	0	0	16 dB
1	0	0	0	0	0	32 dB
1	1	1	1	1	1	63 dB

0 = TTL Low 1 = TTL High

Functional Schematic (Top View)

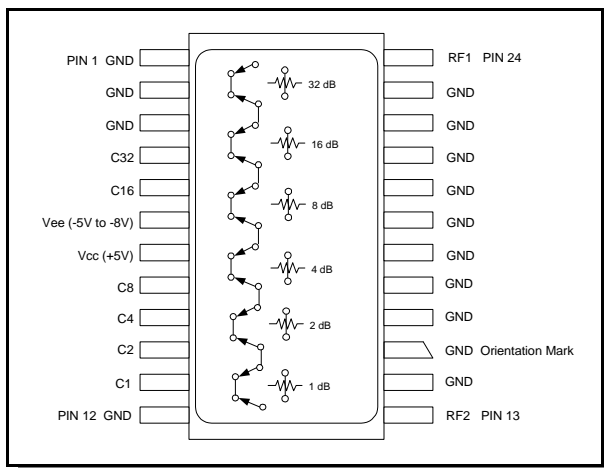

Specifications subject to change without notice.

- North America: Tel. (800) 366-2266
- Asia/Pacific: Tel.+81-44-844-8296, Fax +81-44-844-8298
- Europe: Tel. +44 (1344) 869 595, Fax+44 (1344) 300 020

Visit www.macom.com for additional data sheets and product information.

Typical Performance Curves

Insertion Loss vs. Frequency

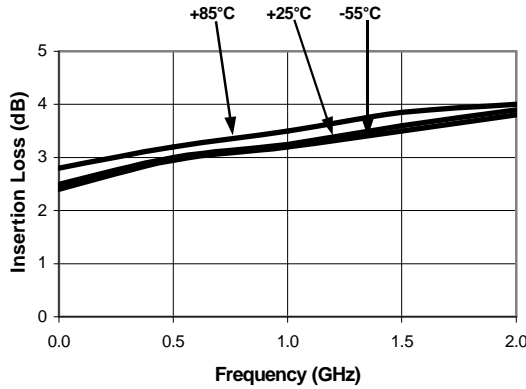

Attenuation Accuracy vs. Frequency

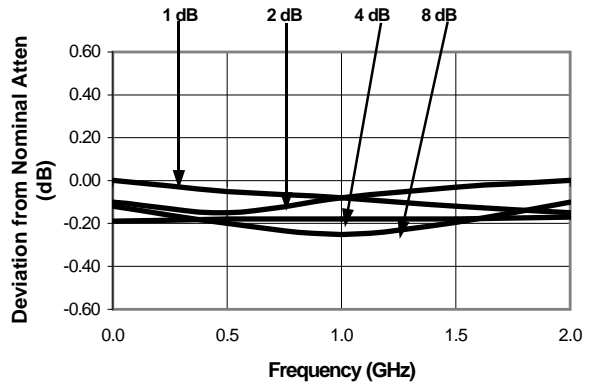

Attenuation Accuracy vs. Frequency

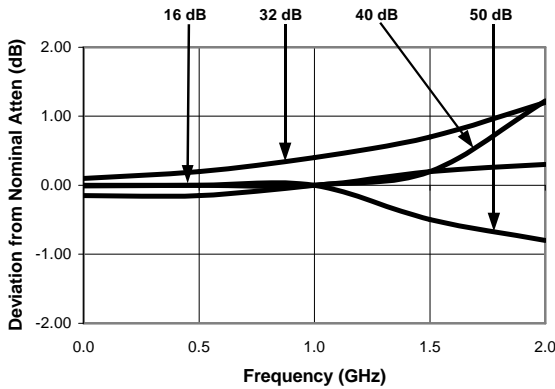

RF1 VSWR vs. Frequency

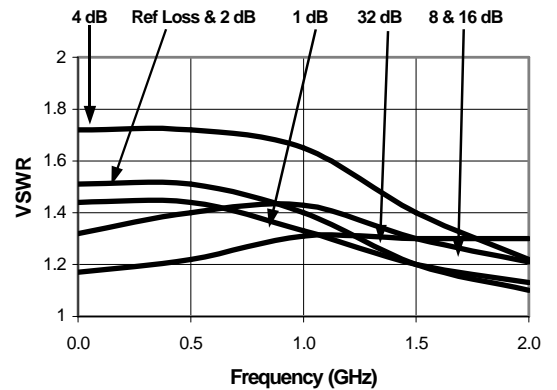

RF2 VSWR vs. Frequency

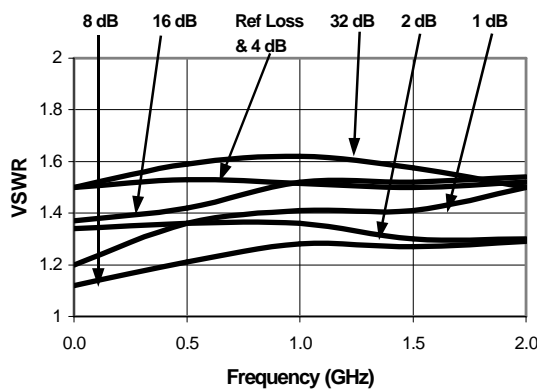

Ordering Information

Part Number	Package
AT20-0106 PIN	CR-13

Specifications subject to change without notice.

- North America: Tel. (800) 366-2266
- Asia/Pacific: Tel.+81-44-844-8296, Fax +81-44-844-8298
- Europe: Tel. +44 (1344) 869 595, Fax+44 (1344) 300 020

Visit www.macom.com for additional data sheets and product information.