

SPDT High Isolation Terminated Switch, 0.5 - 3.0 GHz

MASWSS0024

Features

- Positive Voltage Control (0 / +5 V)
- High Isolation (53 dB typ. @ 0.9 GHz, 50 dB typ @ 1.9 GHz)
- 50-Ohm Internal Terminations
- Low Insertion Loss (0.6 dB typ. @ 0.9 GHz, 0.7 dB typ. @ 1.9 GHz)
- MSOP-8-EP Package

Description

The M/A-COM MASWSS0024 GaAs monolithic switch provides high isolation in a low-cost, plastic surface mount package. The MASWSS0024 is ideal for applications across a broad range of frequencies including synthesizer switching, transmit / receive switching, switch matrices and filter banks in systems such as radio and cellular equipment, PCS, GPS, and fiber optic modules.

M/A-COM fabricates the MASWSS0024 using an 0.5-micron gate length MESFET process. The process features full chip passivation for performance and reliability.

Handling Procedures

The following precautions should be observed to avoid damage:

Static Sensitivity

Gallium arsenide integrated circuits are ESD sensitive and can be damaged by static electricity. Use proper ESD precautions when handling these devices.

Truth Table

V1	V2	RFC-RF1	RFC-RF2
0	1	Off	On
1	0	On	Off

2. External DC blocking capacitors required on all RF ports. We recommend 47 pF.

Functional Block Diagram

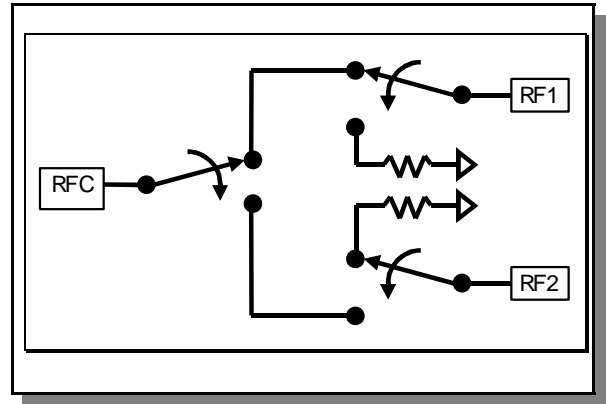

Pin Configuration

Pin	Function	Pin	Function
1	V1	5	RF2
2	V2	6	GND
3	RFC	7	GND
4	GND	8	RF1

Absolute Maximum Ratings ¹

Parameter	Absolute Maximum
Max Input Power (0.5 - 3.0 GHz) 3V Control 5V Control	+30 dBm +33 dBm
Operating Voltage	+8.5 Volts
Operating Temperature	-40°C to +85°C
Storage Temperature	-65°C to +150°C

1. Operation of this device above any one of these parameters may cause permanent damage.

Logic Level	Voltage Level
V_{LO} "0" =	$0 \pm 0.2V$
V_{HIGH} "1" =	$V_C \pm 0.2V$

3. $3.0V \leq V_C \leq 8.0V$

Electrical Specifications: $T_A = 25^\circ\text{C}$, $V_{CTL} = 0, 5.0\text{V}$ (unless otherwise specified)

Parameter	Test Conditions	Frequency	Units	Min	Typ	Max
Insertion Loss	—	0.5 - 1.0 GHz	dB	—	0.6	0.7
		1.0 - 2.0 GHz	dB	—	0.7	0.8
		2.0 - 3.0 GHz	dB	—	0.75	0.9
Isolation	—	0.5 - 1.0 GHz	dB	51	54	—
		1.0 - 2.0 GHz	dB	48	52	—
		2.0 - 3.0 GHz	dB	45	50	—
Return Loss	—	0.5 - 1.0 GHz	dB	15	20	—
		1.0 - 2.0 GHz	dB	15	20	—
		2.0 - 3.0 GHz	dB	15	20	—
Input IP_2	2-Tone 900 MHz, 5 MHz spacing ($V_C = 5.0\text{V}$)	—	dBm	—	83	—
Input IP_3	2-Tone 900 MHz, 5 MHz spacing ($V_C = 5.0\text{V}$)	—	dBm	—	43	—
Trise, Tfall	10% to 90% RF & 90% to 10% RF	—	nS	—	24	—
Ton, Toff	50% of V_C to 10% / 90% RF	—	nS	—	15	—
Transients	$V_C = 5.0\text{V}$ square wave, in-band	—	mV	—	12	—

4. DC blocking capacitors required on all RF ports.

MSOP-8-EP

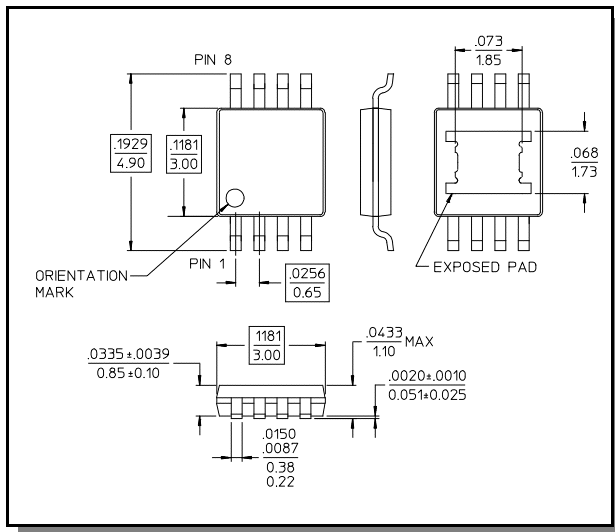

Specifications subject to change without notice.

- North America: Tel. (800) 366-2266
- Asia/Pacific: Tel.+81-44-844-8296, Fax +81-44-844-8298
- Europe: Tel. +44 (1344) 869 595, Fax+44 (1344) 300 020

Visit www.macom.com for additional data sheets and product information.

Typical Performance Curves

Return Loss vs. Frequency

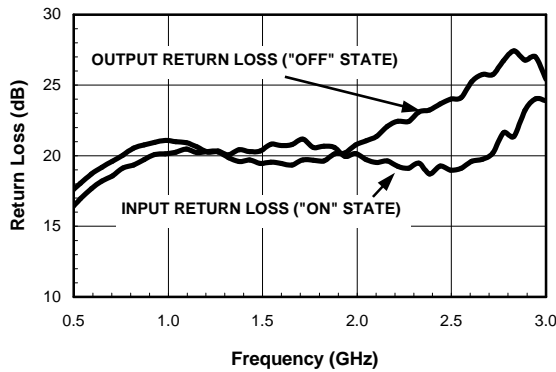

Insertion Loss vs. Temperature

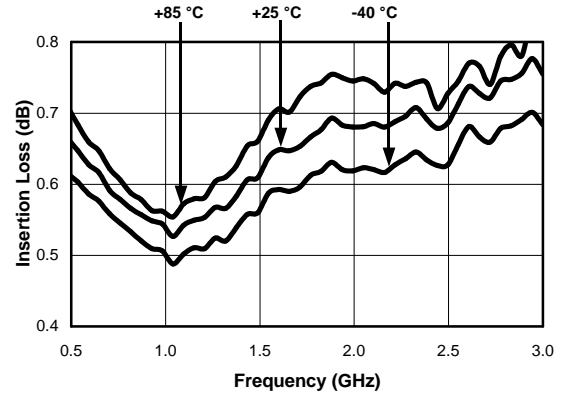

Isolation vs. Frequency over Temperature

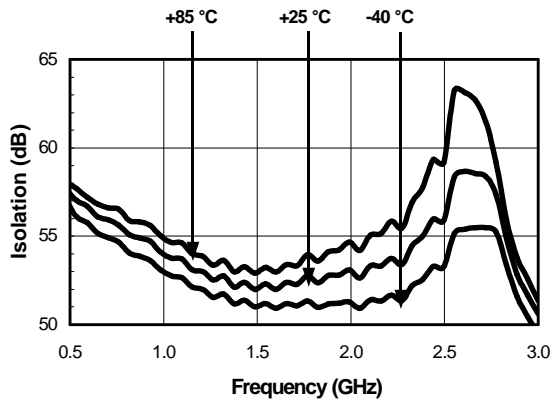

Ordering Information

Part Number	Package
MASWSS0024	Bulk Packaging
MASWSS0024TR	Tape and Reel (1K Reel)
MASWSS0024TR-3000	Tape and Reel (3K Reel)
MASWSS0024SMB	Sample Board

Specifications subject to change without notice.

- North America: Tel. (800) 366-2266
- Asia/Pacific: Tel.+81-44-844-8296, Fax +81-44-844-8298
- Europe: Tel. +44 (1344) 869 595, Fax+44 (1344) 300 020

Visit www.macom.com for additional data sheets and product information.

