

MAS9122

3 Outputs LDO Voltage Regulator IC

- Three Low Dropout Voltage Regulators
- Very Low Noise: 25 μVrms
- High Ripple Rejection: 63 dB
- Very Low Crosstalk
- Low Ground Pin Current
- Regulator Enable/Disable Control

DESCRIPTION

MAS9122 is a three output voltage regulator. It is designed for three different output voltages, which can be modified through a mask option. Regulators operating mode is controlled by two enable/disable pins. The circuit consists of a bandgap voltage reference, an error amplifier, a current limit circuit and a thermal protection circuit.

MAS9122 features very low ground pin current: typically less than 1.5 μA sleep mode current and typical 125 μA for one regulator in active mode. Excellent noise and PSRR performance enables the use of MAS9122 in high precision portable devices. Low crosstalk between regulators provides an area efficient solution compared to single regulators.

FEATURES

- Three Regulators at 135 mA, 70 mA and 50 mA
- Output Options 2.70, 2.85 and 3.00 V, see Ordering Information p. 12
- Low Noise: 20 μVrms Typical and 30 μVrms Maximum for All Regulators over Frequency Range 100 Hz...100 kHz
- Fast Dynamic Response
- Output Voltage Accuracy $< \pm 2.0\%$
- MSOP-8 Package

APPLICATION

- Systems Requiring Stabilized Power in Separate Blocks
- Cordless Phones
- Mobile Phones
- Portable Systems
- Battery Powered Systems

BLOCK DIAGRAM

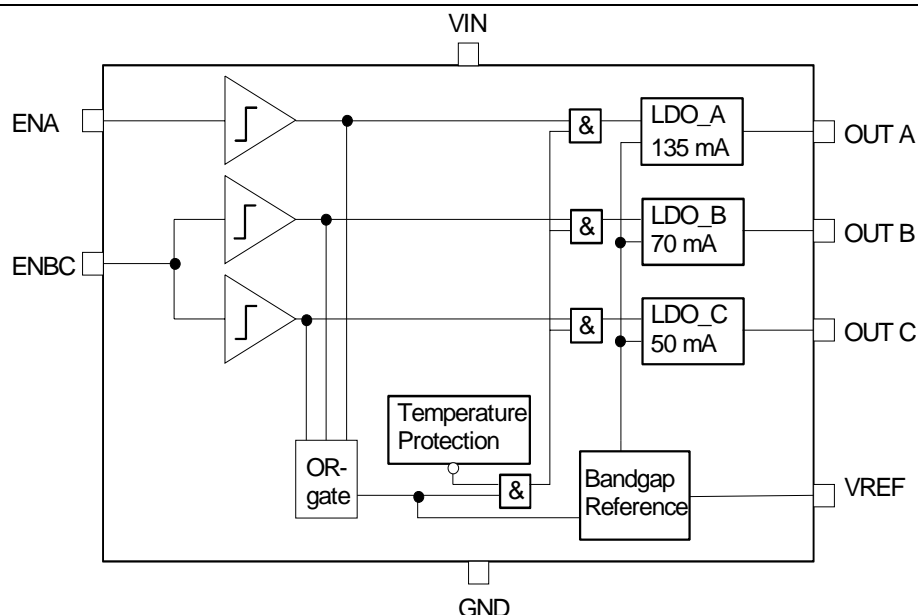

PIN CONFIGURATION

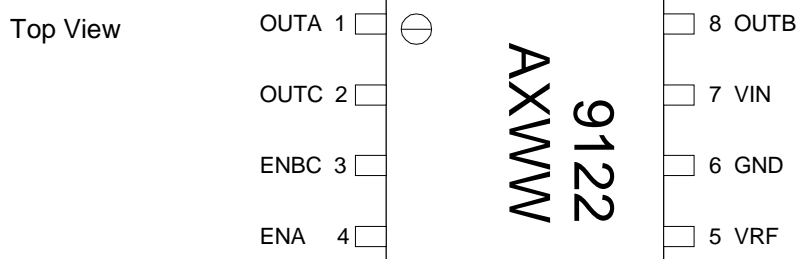

Top Marking Information:
AX = voltage version, see p.12 Ordering information
WW = week

PIN DESCRIPTION

Pin Name	Pin	Type	Function
OUTA	1	O	135 mA Regulator Output
OUTC	2	O	50 mA Regulator Output
ENBC	3	I	Enable for Regulators B and C
ENA	4	I	Enable for Regulator A
VREF	5	O	Reference Voltage: Pin for Bypass Capacitor
GND	6	P	Ground
VIN	7	P	Positive Supply Voltage
OUTB	8	O	70 mA Regulator Output

G = Ground, I = Input, O = Output, P = Power

ABSOLUTE MAXIMUM RATINGS

All Voltages with Respect to Ground

Parameter	Symbol	Conditions	Min	Max	Unit
Supply Voltage	V_{IN}		-0.3	6	V
Voltage Range for All Pins			-0.3	$V_{IN} + 0.3$	V
ESD Rating		HBM		2	kV
Junction Temperature	T_{Jmax}			175 (limited)	°C
Storage Temperature	T_S		-55	+150	°C

Stresses beyond those listed may cause permanent damage to the device. The device may not operate under these conditions, but will not be destroyed.

Parameter	Symbol	Conditions	Min	Max	Unit
Supply Voltage	V_{IN}		$V_{OUT(NOM)} + 0.25$	5.3	V
Operating Junction Temperature	T_J		-40	+125	°C
Operating Ambient Temperature	T_A		-40	+85	°C

ELECTRICAL CHARACTERISTICS

$T_A = -40^{\circ}\text{C}$ to $+85^{\circ}\text{C}$, typical values at $T_A = +27^{\circ}\text{C}$, $V_{IN} = 4.5\text{ V}$, $I_{OUT} = 1.0\text{ mA}$, $C_{IN} = 1.0\text{ }\mu\text{F}$, $C_L = 1.0\text{ }\mu\text{F}$, $C_{BYPASS} = 10\text{ nF}$, $V_{CTRL} = 2.0\text{ V}$, unless otherwise specified.

◆ Thermal Protection

Parameter	Symbol	Conditions	Min	Typ	Max	Unit
Threshold High	T_H		130	150	170	°C
Threshold Low	T_L		120	140	160	°C

The hysteresis of 10°C prevents the device from turning on too soon after thermal shut-down.

◆ Control Pin Parameters

Parameter	Symbol	Conditions	Min	Typ	Max	Unit
Input Voltage	ENA, ENBC		-0.3		$V_{IN} + 0.3$	V
ON-state OFF-state			2.0		0.3	

If CTRL-pin is not connected, the particular regulator(s) is/are in OFF state (900 k Ω pull-down resistor to ground).

◆ Current Parameters

Parameter	Symbol	Conditions	Min	Typ	Max	Unit
LDO_A Continuous Output Current	I_{OUTA}		0		135	mA
LDO_B Continuous Output Current	I_{OUTB}		0		70	mA
LDO_C Continuous Output Current	I_{OUTC}		0		50	mA
Short Circuit Current for LDO_A	I_{SHORTA}			350		mA
Short Circuit Current for LDO_B	I_{SHORTB}			265		mA
Short Circuit Current for LDO_C	I_{SHORTC}			230		mA
Ground Pin Current	$I_{GND(OFF)}$	$I_{OUT} = 0 \text{ A}, V_{ENA,ENBC} < 0.3 \text{ V}, V_{IN} = 3.6$		2	4	μA
Ground Pin Current	$I_{GND(ONA)}$	$I_{OUT} = 0 \text{ A}, V_{ENA} > 2 \text{ V}, V_{ENBC} < 0.3 \text{ V}, V_{IN} = 3.6$		125		μA
Ground Pin Current	$I_{GND(ONBC)}$	$I_{OUT} = 0 \text{ A}, V_{ENA} < 0.3 \text{ V}, V_{ENBC} > 2 \text{ V}, V_{IN} = 3.6$		170		μA
Ground Pin Current	$I_{GND(ONABC)}$	$I_{OUT} = 0 \text{ A}, V_{ENA, ENBC} > 2 \text{ V}, V_{IN} = 3.6$		245		μA

◆ Voltage Parameters

Parameter	Symbol	Conditions	Min	Typ	Max	Unit
Output Voltage: Mask option for 2.85 V	V_{OUTA}	Max $I_{OUT} = 135 \text{ mA}$	2.85 – 3%	2.85	2.85 + 2%	V
	$V_{OUTA,B,C}$	Max $I_{OUTA} = 100 \text{ mA}, \text{Max } I_{OUTB} = 70 \text{ mA}, \text{Max } I_{OUTC} = 50 \text{ mA}$	2.85 – 2%	2.85	2.85 + 2%	V
LDO_A Dropout Voltage	V_{DROPA}	$I_{OUTA} = 135 \text{ mA}$ $I_{OUTA} = 100 \text{ mA}$		220 180		mV
LDO_B Dropout Voltage	V_{DROPB}	$I_{OUTB} = 70 \text{ mA}$		165		mV
LDO_C Dropout Voltage	V_{DROPC}	$I_{OUTC} = 50 \text{ mA}$		150		mV

◆ External Capacitors

Parameter	Symbol	Conditions	Min	Typ	Max	Unit
Output Capacitors for all Regulators	$C_{OUTA,B,C}$		0.8	1		μF
Effective Series Resistance	ESR		0.01	0.1	2	Ω
Bypass Capacitor	C_{BYPASS}			10		nF

◆ Power Dissipation

Parameter	Symbol	Conditions	Min	Typ	Max	Unit
Junction to Case Thermal Resistance	R_{JC}			39		$^{\circ}\text{C/W}$
Junction to Ambient Thermal Resistance	R_{JA}	typical PC board mounting, still air		206		$^{\circ}\text{C/W}$
Maximum Power Dissipation	P_d	any ambient temperature		$P_{dMAX} = \frac{T_{J(MAX)} - T_A}{R_{JA}}$ Note 1		mW

Note 1: $T_{J(MAX)}$ denotes maximum operating junction temperature (+125 $^{\circ}\text{C}$), T_A ambient temperature, and R_{JA} junction-to-ambient thermal resistance (+206 $^{\circ}\text{C/W}$).

◆ Load Regulation

Parameter	Symbol	Conditions	Min	Typ	Max	Unit
Load Regulation LDO_A		$0 \text{ mA} < I_{OUT} < 135 \text{ mA}$		22	50	mV
		$0 \text{ mA} < I_{OUT} < 100 \text{ mA}$		22	30	
Load Regulation LDO_B		$0 \text{ mA} < I_{OUT} < 70 \text{ mA}$		21	25	mV
Load Regulation LDO_C		$0 \text{ mA} < I_{OUT} < 50 \text{ mA}$		13	22	mV

◆ Line Regulation

Parameter	Symbol	Conditions	Min	Typ	Max	Unit
Line Regulation for all LDOs		$I_{OUT} = I_{MAX}, V_{IN}$ from 5.3 V to 3.1 V		0.40	1.2	mV

◆ PSRR

Parameter	Symbol	Conditions	Min	Typ	Max	Unit
PSRR for all LDOs		$I_{OUT} = \text{Max } I_{OUT}$ $V_{IN} = 3.6 \text{ V}$ $f = 1 \text{ kHz}$ $f = 10 \text{ kHz}$	47	75 63		dB

◆ Noise and Crosstalk

Parameter	Symbol	Conditions	Min	Typ	Max	Unit
Noise Voltage for all LDOs	V_{NO}	$100 \text{ Hz} < f < 100 \text{ kHz}$		25	30	μVrms

◆ Dynamic Parameters

Parameter	Symbol	Conditions	Min	Typ	Max	Unit
Start-up Delay (from enabling LDO_A to 90% * $V_{OUT(NOM)}$, other LDOs at ON state) (Note 2)		V_{ENA} from $< 0.3 \text{ V}$ to $> 2.0 \text{ V}$, $V_{ENBC} > 2.0 \text{ V}$, $I_{OUT} = \text{Max } I_{OUT}$, $C_{OUTA} = 1 \mu\text{F}$		25		μs
Overshoot		V_{ENA} from $< 0.3 \text{ V}$ to $> 2.0 \text{ V}$, $V_{ENBC} > 2.0 \text{ V}$, $I_{OUT} = \text{Max } I_{OUT}$, $C_{OUTA} = 1 \mu\text{F}$		1		%
Settling Time (from 90% * $V_{OUT(NOM)A}$ to max $\pm 0.1\%$ fluctuation)		V_{ENA} from $< 0.3 \text{ V}$ to $> 2.0 \text{ V}$, $V_{ENBC} > 2.0 \text{ V}$, $I_{OUT} = \text{Max } I_{OUT}$, $C_{OUTA} = 1 \mu\text{F}$, w/o C_{BYPASS}		200		μs

Note 2: When all regulators are disabled the start-up delay is a function of a bypass capacitor. Typically 0.5 ms for 10 nF capacitor.

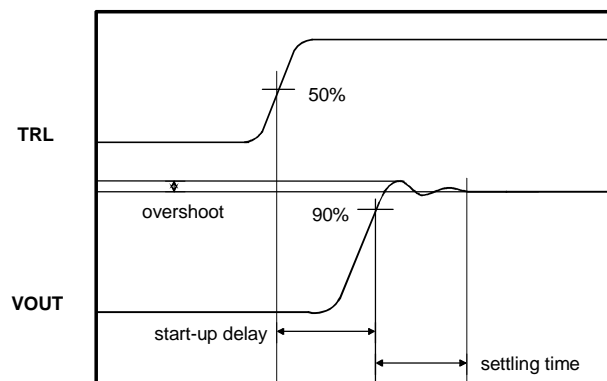
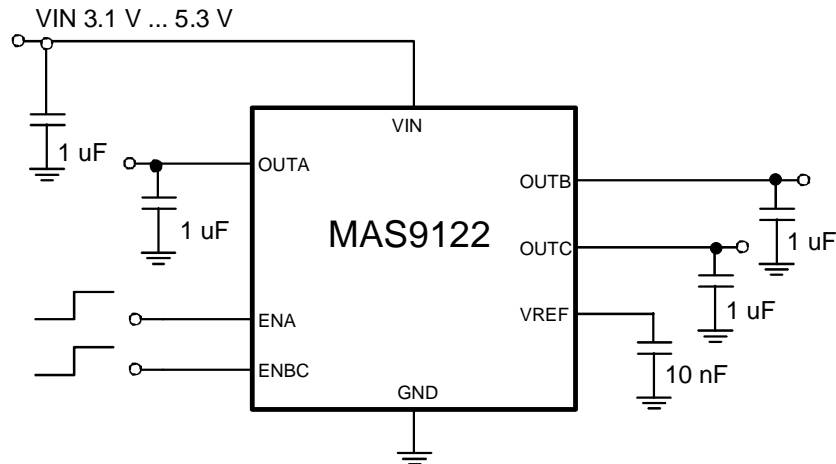

Figure 1. Definitions of start-up delay, overshoot and settling time.

APPLICATION INFORMATION



See also table External Capacitors on p. 4.

FUNCTIONS

◆ Reference voltage

The device is supplied with 3.1 V to 5.3 V battery under normal conditions. An internal bandgap voltage reference is routed via 20 kOhm resistor to an external pin, where a filter capacitor can be connected in order to reduce noise level of all regulators. The startup time of the reference voltage is then determined by the value of the bypass capacitor at pin VREF.

◆ Enable pins

Each regulator can be enabled/disabled by two enable pins ENA and ENBC. Pin ENA controls regulator LDO_A and pin ENBC controls both

regulator LDO_B and LDO_C. If both enable pins are forced low, the whole circuit goes into power saving sleep-mode. In the table below all functional modes are presented.

◆ Regulators

The device contains three low dropout CMOS regulators, with maximum output currents of 135 mA, 70 mA and 50 mA. Three different output voltage options are available by mask option: 2.70 V, 2.85 V and 3.00 V.

◆ Logic Table for Enable Inputs

ENA	ENBC	LDO_A	LDO_B	LDO_C	VREF
1	1	ON	ON	ON	ON
1	0	ON	OFF	OFF	ON
0	1	OFF	ON	ON	ON
0	0	OFF	OFF	OFF	OFF

TYPICAL PERFORMANCE

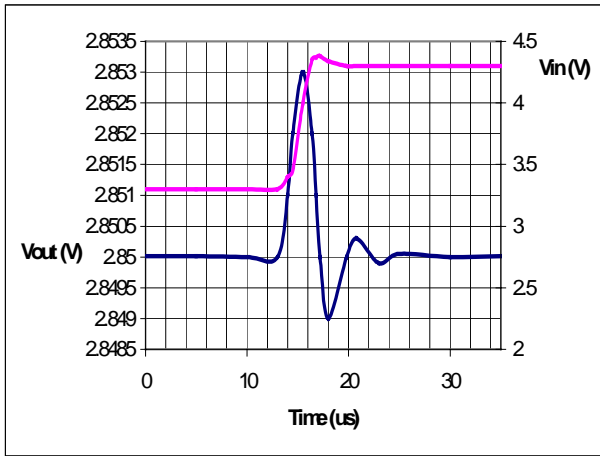

Figure 2. LDO_C line transient for 1 V change at supply voltage.

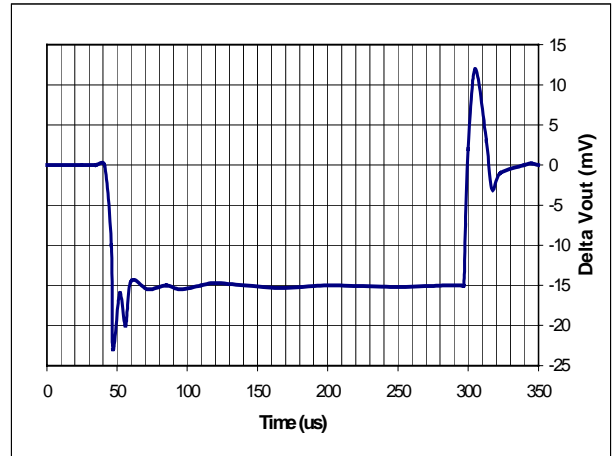

Figure 5. LDO_A load transient response to maximum output current with 10 μ s steps (I_{OUT} max 100 mA).
NOTE: With 135 mA current the overshoot values and lengths will grow by 30% compared to 100 mA current.

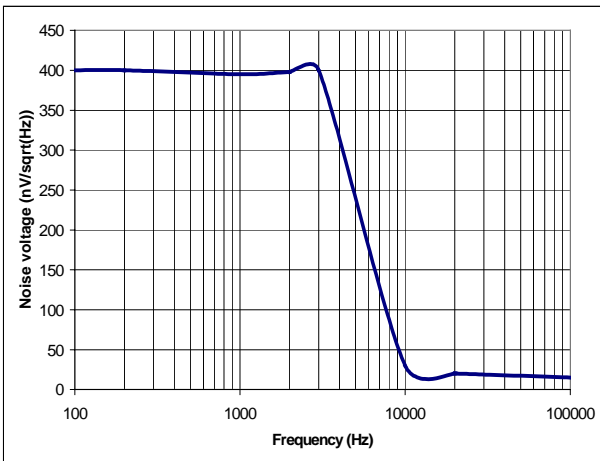

Figure 3. Regulator output noise density.

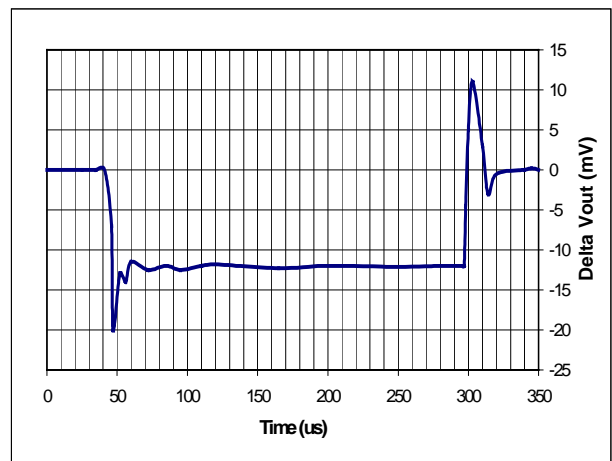

Figure 6. LDO_B load transient response to maximum output current with 10 μ s steps.

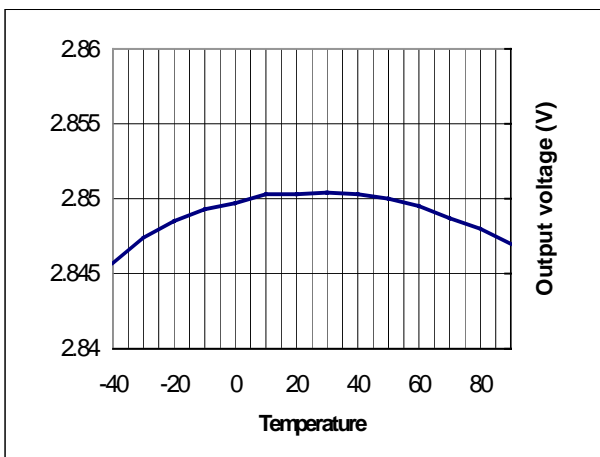

Figure 4. Regulator output voltage temperature dependency.

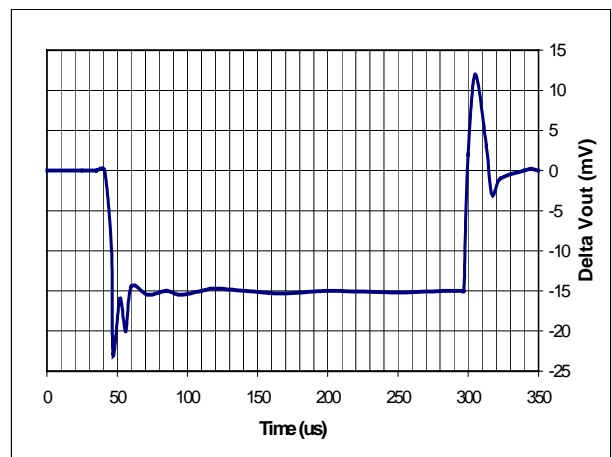

Figure 7. LDO_C load transient response to maximum output current with 10 μ s steps.

TYPICAL PERFORMANCE

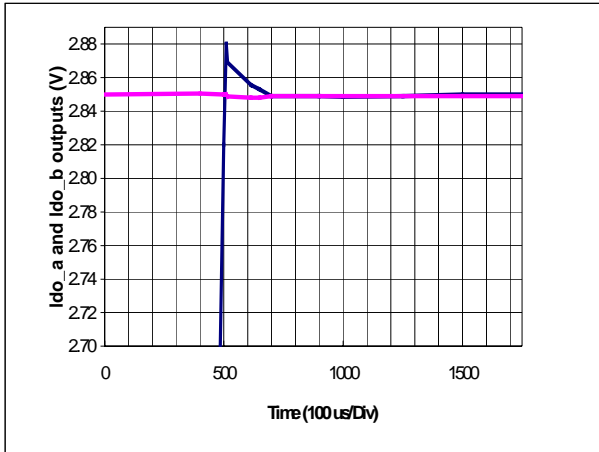

Figure 8. LDO_A start-up, overshoot and cross-coupling to LDO_B.

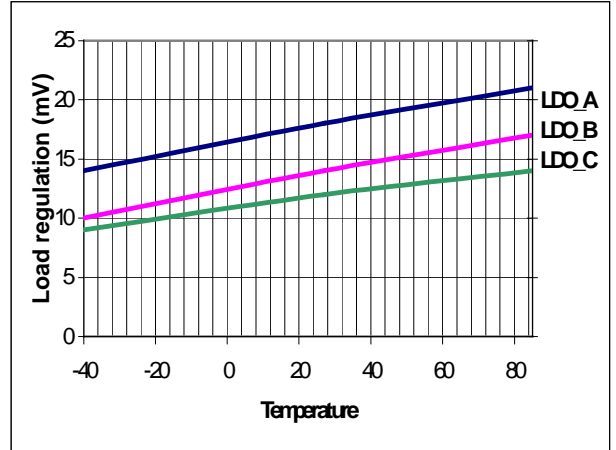

Figure 11. Load regulation vs. temperature.

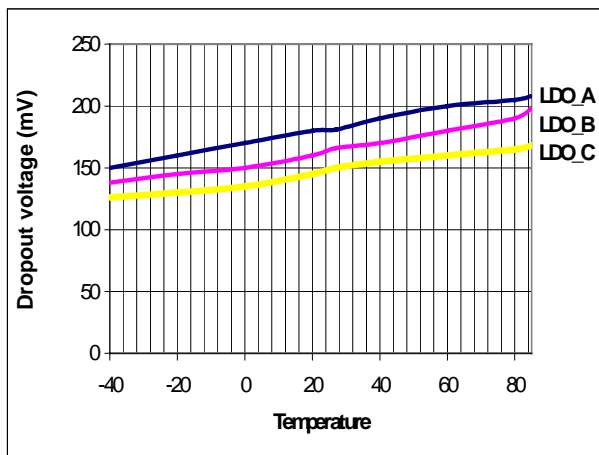

Figure 9. Dropout voltage temperature dependency with maximum output current.

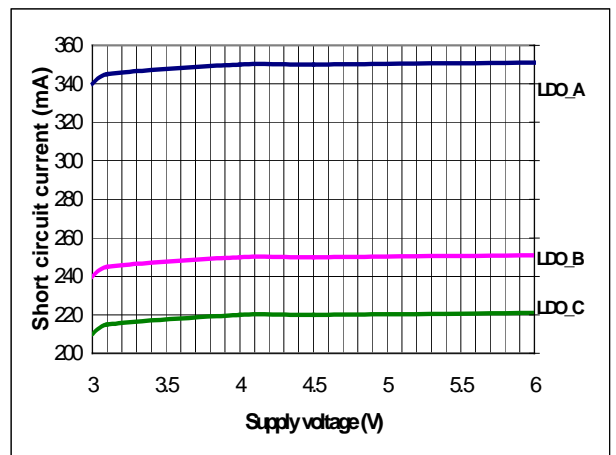

Figure 12. Short circuit current variation vs. supply voltage.

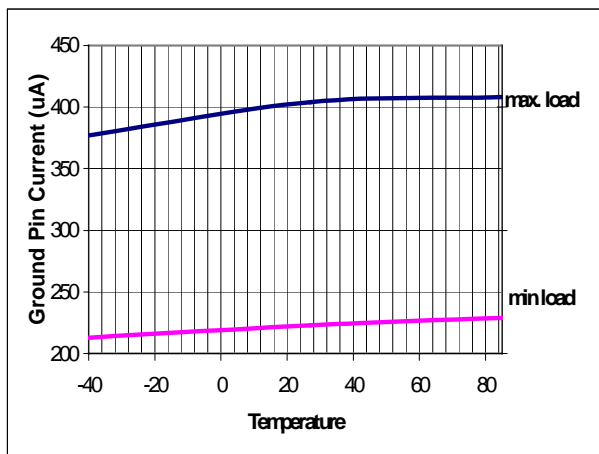

Figure 10. Total ground pin current vs. temperature.

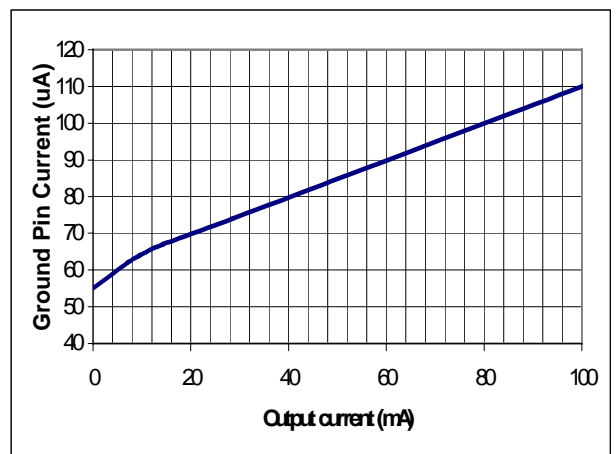
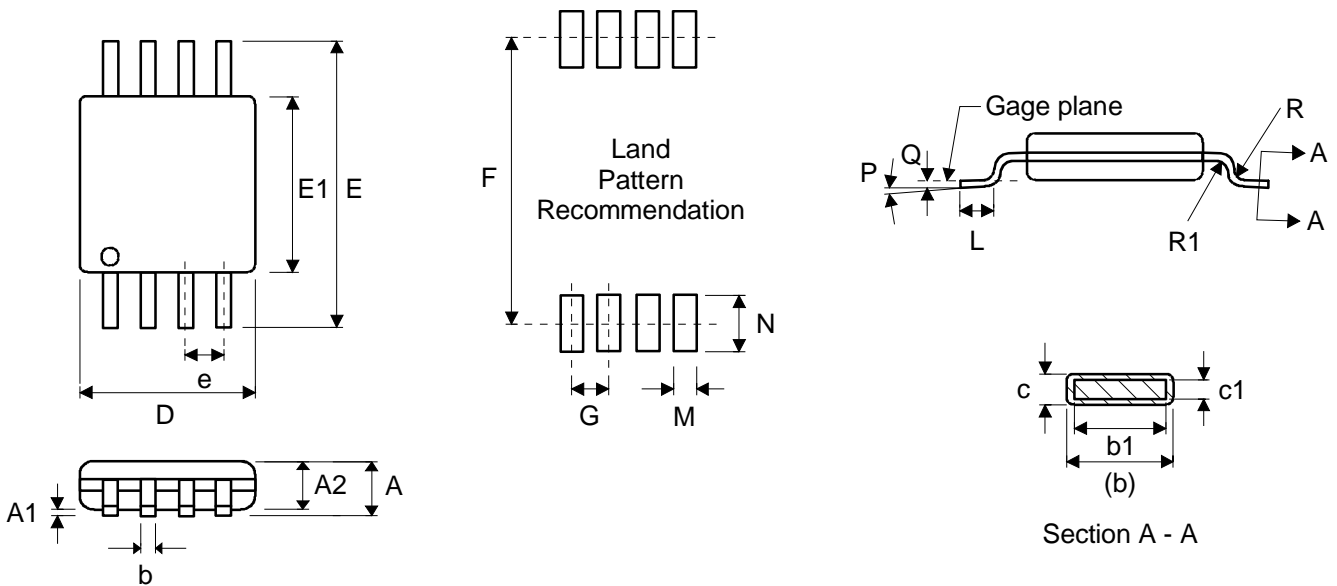

Figure 13. LDO_A ground pin current vs. output current.

PACKAGE (MSOP-8) OUTLINE

Symbol	Min	Nom	Max	Unit
A			1.10	mm
A1	0		0.15	mm
A2	0.75	0.85	0.95	mm
b	0.22		0.38	mm
b1	0.22	0.30	0.33	mm
c	0.08		0.23	mm
c1	0.08		0.18	mm
D		3.00 BSC		mm
E		4.90 BSC		mm
E1		3.00 BSC		mm
e		0.65 BSC		mm
F		4.8		mm
G		0.65		mm
L (Terminal length for soldering)	0.40	0.60	0.80	mm
M		0.41		mm
N		1.02		mm
P	0°		8°	
Q		0.25 BSC		mm
R	0.07			mm
R1	0.07			mm

Dimensions do not include mold or interlead flash, protrusions or gate burrs.
 All measurement according to JEDEC standard MO-187.

SOLDERING INFORMATION

Resistance to Soldering Heat	According to RSH test IEC 68-2-58/20 2*220°C
Maximum Reflow Temperature	235°C
Maximum Number of Reflow Cycles	2
Seating Plane Co-planarity	max 0.08 mm
Lead Finish	Solder plate 7.62 - 25.4 μm, material Sn 85% Pb 15%

EMBOSSED TAPE SPECIFICATIONS

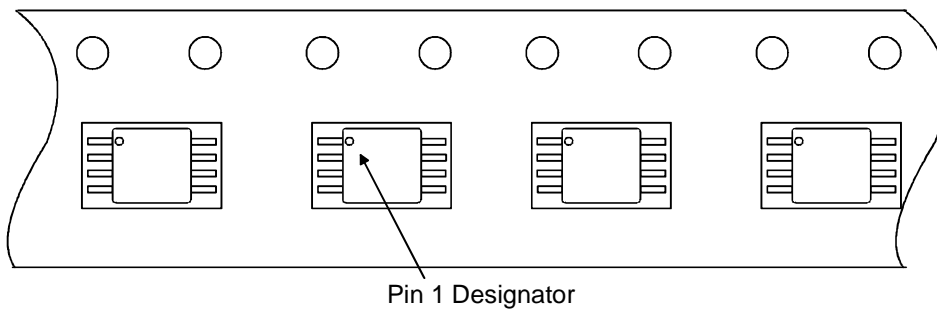
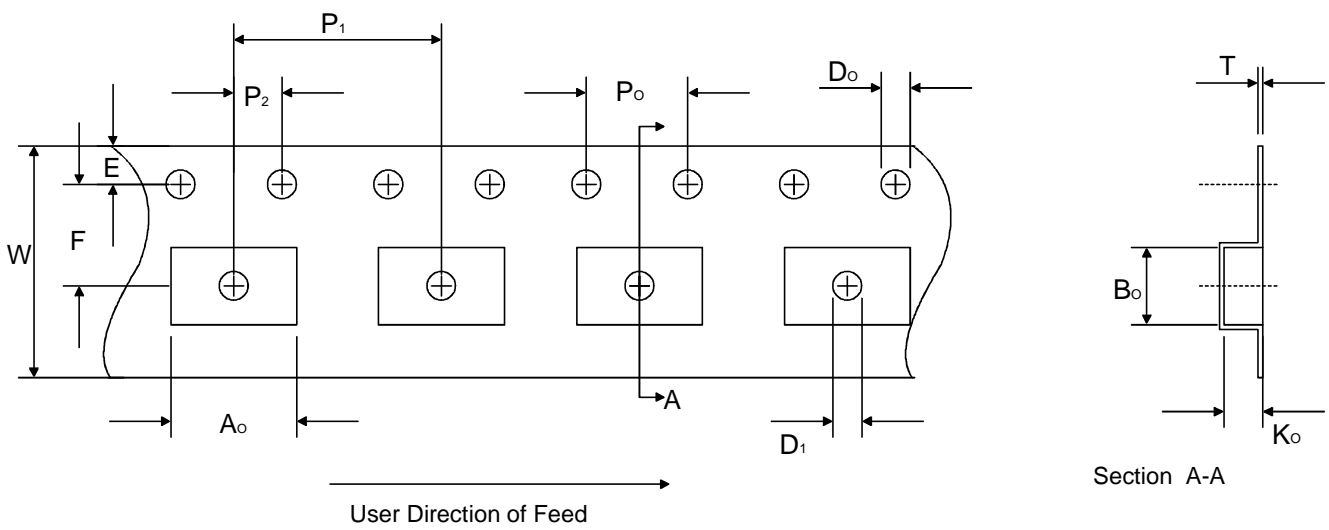

Dimension	Min/Max	Unit
A_o	5.00 ±0.10	mm
B_o	3.20 ±0.10	mm
D_o	1.50 +0.1/-0.0	mm
D_1	1.50 min	mm
E	1.75	mm
F	5.50 ±0.05	mm
K_o	1.45 ±0.10	mm
P_o	4.0	mm
P_1	8.0 ±0.10	mm
P_2	2.0 ±0.05	mm
T	0.3 ±0.05	mm
W	12.00 +0.30/-0.10	mm

REEL SPECIFICATIONS

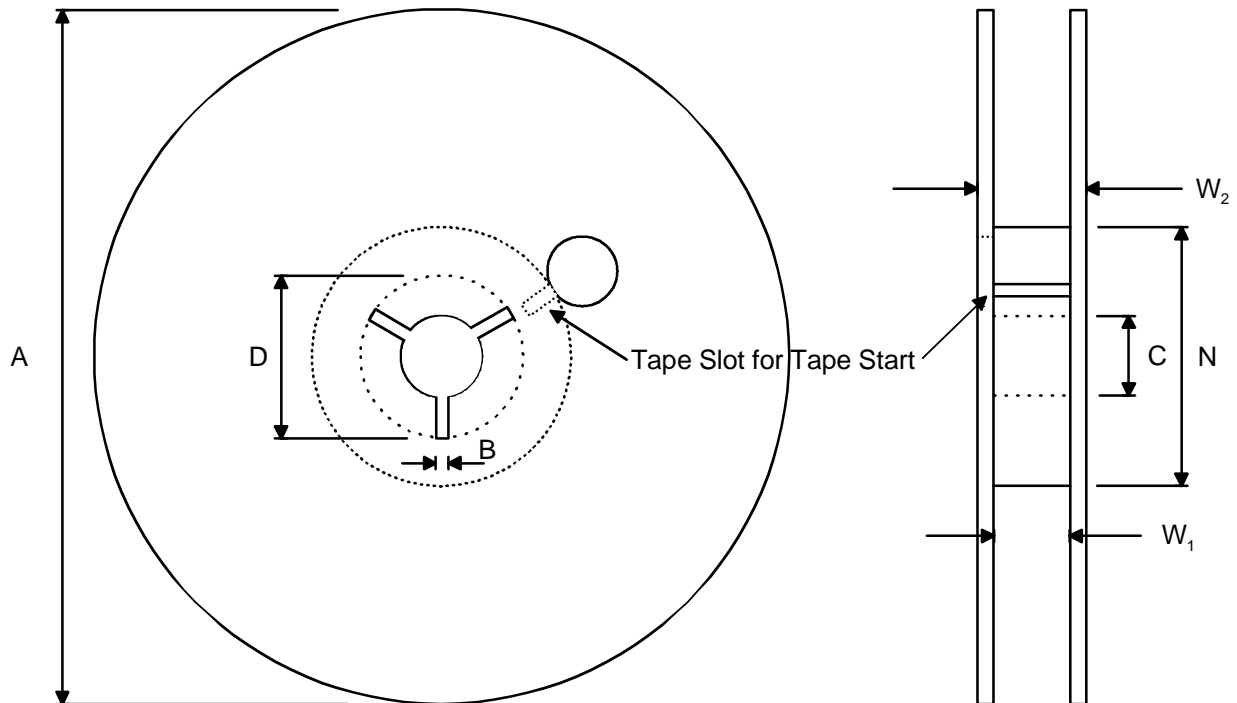

5000 Components on Each Reel

Reel Material: Conductive, Plastic Antistatic or Static Dissipative

Carrier Tape Material: Conductive

Cover Tape Material: Static Dissipative

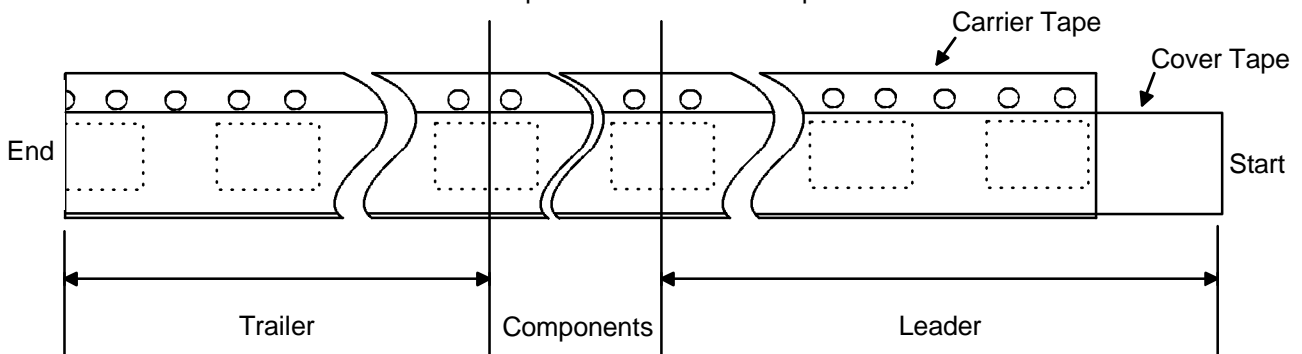

Dimension	Min	Max	Unit
A		330	mm
B	1.5		mm
C	12.80	13.50	mm
D	20.2		mm
N	50		mm
W ₁ (measured at hub)	12.4	14.4	mm
W ₂ (measured at hub)		18.4	mm
Trailer	160		mm
Leader	390, of which minimum 160 mm of empty carrier tape sealed with cover tape		mm
Weight		1500	g

ORDERING INFORMATION

Product Code	Product	Top Marking (ax)	Package	Comments
MAS9122ASM2-T	3 x 2.70 V LDO Voltage Regulator IC	A2	MSOP-8	Tape & Reel
MAS9122ASM3-T	3 x 2.85 V LDO Voltage Regulator IC	A3	MSOP-8	Tape & Reel
MAS9122ASM4-T	3 x 3.00 V LDO Voltage Regulator IC	A4	MSOP-8	Tape & Reel

For more voltage options contact Micro Analog Systems Oy.

LOCAL DISTRIBUTOR

MICRO ANALOG SYSTEMS OY CONTACTS

Micro Analog Systems Oy Kamreerintie 2, P.O.Box 51 FIN-02771 Espoo, FINLAND http://www.mas-oy.com	Tel. (09) 80 521 Tel. Int. +358 9 80 521 Telefax +358 9 805 3213 E-mail: info@mas-oy.com
--	--

NOTICE

Micro Analog Systems Oy reserves the right to make changes to the products contained in this data sheet in order to improve the design or performance and to supply the best possible products. Micro Analog Systems Oy assumes no responsibility for the use of any circuits shown in this data sheet, conveys no license under any patent or other rights unless otherwise specified in this data sheet, and makes no claim that the circuits are free from patent infringement. Applications for any devices shown in this data sheet are for illustration only and Micro Analog Systems Oy makes no claim or warranty that such applications will be suitable for the use specified without further testing or modification.