



Improved, Quad, SPST Analog Switches

DG444/DG445

General Description

Maxim's redesigned DG444/DG445 analog switches now feature on-resistance matching (4Ω max) between switches and guaranteed on-resistance flatness over the signal range (9Ω max). These low on-resistance switches conduct equally well in either direction. They guarantee low charge injection (10pC max), low power consumption ($35\mu\text{W}$ max), and an ESD tolerance of 2000V minimum per Method 3015.7. The new design offers lower off leakage current over temperature (less than 5nA at $+85^\circ\text{C}$).

The DG444/DG445 are quad, single-pole/single-throw (SPST) analog switches. The DG444 has 4 normally closed switches and the DG445 has 4 normally open switches. Switching times are less than 250ns for t_{ON} and less than 70ns for t_{OFF} . Operation is from a single $+10\text{V}$ to $+30\text{V}$ supply, or bipolar $\pm 4.5\text{V}$ to $\pm 20\text{V}$ supplies. Maxim's improved DG444/DG445 continue to be fabricated with a 44V silicon-gate process.

Applications

Sample-and-Hold Circuits	Communication Systems
Test Equipment	Battery-Operated Systems
Heads-Up Displays	PBX, PABX
Guidance and Control Systems	Audio Signal Routing
Military Radios	Modems/Faxes

New Features

- ◆ Plug-In Upgrades for Industry-Standard DG444/DG445
- ◆ Improved r_{ON} Match Between Channels (4Ω max)
- ◆ Guaranteed $r_{\text{FLAT(ON)}}$ Over Signal Range (9Ω max)
- ◆ Improved Charge Injection (10pC max)
- ◆ Improved Off Leakage Current Over Temperature ($<5\text{nA}$ at $+85^\circ\text{C}$)
- ◆ Withstand Electrostatic Discharge (2000V min) per Method 3015.7

Existing Features

- ◆ Low $r_{\text{DS(ON)}}$ (85Ω max)
- ◆ Single-Supply Operation $+10\text{V}$ to $+30\text{V}$
Bipolar-Supply Operation $\pm 4.5\text{V}$ to $\pm 20\text{V}$
- ◆ Low Power Consumption ($35\mu\text{W}$ max)
- ◆ Rail-to-Rail Signal Handling
- ◆ TTL/CMOS-Logic Compatible

Ordering Information

PART	TEMP. RANGE	PIN-PACKAGE
DG444CJ	0°C to $+70^\circ\text{C}$	16 Plastic DIP
DG444DY	0°C to $+70^\circ\text{C}$	16 Narrow SO
DG444C/D	0°C to $+70^\circ\text{C}$	Dice*
DG444DJ	-40°C to $+85^\circ\text{C}$	16 Plastic DIP
DG444DY	-40°C to $+85^\circ\text{C}$	16 Narrow SO

Ordering Information continued at end of data sheet.

* Contact factory for dice specifications.

Pin Configurations/Functional Diagrams/Truth Tables

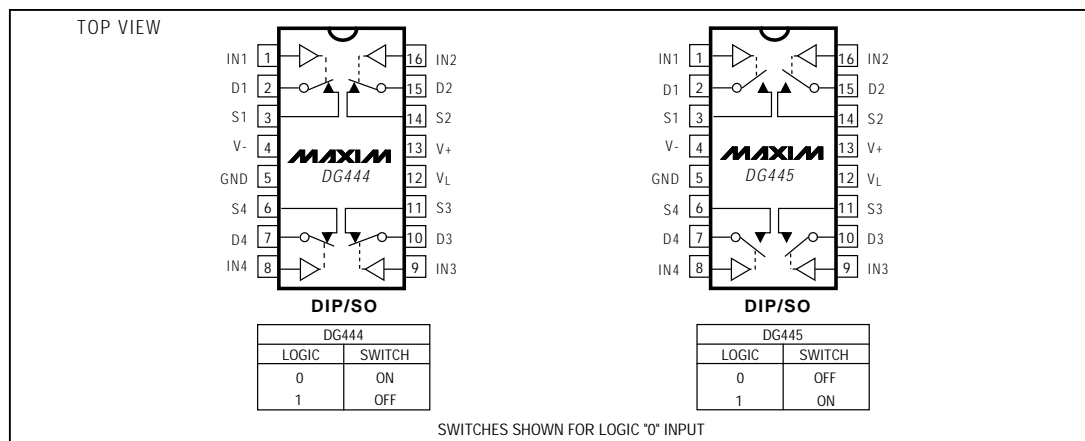

Improved, Quad, SPST Analog Switches

DG444/DG445

ABSOLUTE MAXIMUM RATINGS

Voltage Referenced to V-	Continuous Power Dissipation (T _A = +70°C)
V ₊44V	16-Pin Plastic DIP (derate 10.53mW/°C above +70°C) 842mW
GND25V	16-Pin Narrow SO (derate 8.70mW/°C above +70°C) ..696mW
V _L(GND -0.3V) to (V ₊ +0.3V)	Operating Temperature Ranges
Digital Inputs V _S , V _D (Note 1).....(V ₋ -2V) to (V ₊ +2V) or 30mA	DG444C/DG445C0°C to +70°C
(whichever occurs first)	DG444D/DG445D-40°C to +85°C
Continuous Current (any terminal).....30mA	Storage Temperature Range-65°C to +150°C
Peak Current, S or D (pulsed at 1ms, 10% duty cycle max) .100mA	Lead Temperature (soldering, 10sec)+300°C

Note 1: Signals on S, D, or IN exceeding V₊ or V₋ are clamped by internal diodes. Limit forward current to maximum current rating.

Stresses beyond those listed under "Absolute Maximum Ratings" may cause permanent damage to the device. These are stress ratings only, and functional operation of the device at these or any other conditions beyond those indicated in the operational sections of the specifications is not implied. Exposure to absolute maximum rating conditions for extended periods may affect device reliability.

ELECTRICAL CHARACTERISTICS—Dual Supplies

(V₊ = 15V, V₋ = -15V, V_L = 5V, GND = 0V, V_{INH} = 2.4V, V_{INL} = 0.8V, T_A = T_{MIN} to T_{MAX}, unless otherwise noted.)

PARAMETER	SYMBOL	CONDITIONS	MIN	TYP (Note 2)	MAX	UNITS
SWITCH						
Analog Signal Range	V _{ANALOG}	(Note 3)	-15		15	V
Drain-Source On-Resistance	r _{DS(ON)}	V ₊ = 13.5V, V ₋ = -13.5V, V _D = ±8.5V, I _S = -10mA		50	85	Ω
		T _A = T _{MIN} to T _{MAX}			100	
On-Resistance Match Between Channels (Note 4)	Δr _{DS(ON)}	V _D = ±10V, I _S = -10mA			4	Ω
		T _A = T _{MIN} to T _{MAX}			5	
On-Resistance Flatness (Note 4)	r _{FLAT(ON)}	V _D = ±5V, I _S = -10mA			9	Ω
		T _A = T _{MIN} to T _{MAX}			15	
Source Leakage Current (Note 5)	I _{S(OFF)}	V ₊ = 16.5V, V ₋ = -16.5V, V _D = ±15.5V, V _S = ∓15.5V	-0.50	0.01	0.50	nA
		T _A = T _{MIN} to T _{MAX}	-5		5	
Drain-Off Leakage Current (Note 5)	I _{D(OFF)}	V ₊ = 16.5V, V ₋ = -16.5V, V _D = ±15.5V, V _S = ∓15.5V	-0.50	0.01	0.50	nA
		T _A = T _{MIN} to T _{MAX}	-5		5	
Drain-On Leakage Current (Note 5)	I _{D(ON)} or I _{S(ON)}	V ₊ = 16.5V, V ₋ = -16.5V, V _D = ±15.5V, V _S = ±15.5V	-0.50	0.08	0.50	nA
		T _A = T _{MIN} to T _{MAX}	-10		10	
INPUT						
Input Current with Input Voltage High	I _{INH}	V _{IN} = 2.4V, all others = 0.8V	-0.5	-0.00001	0.5	μA
Input Current with Input Voltage Low	I _{INL}	V _{IN} = 0.8V, all others = 2.4V	-0.5	-0.00001	0.5	μA

Improved, Quad, SPST Analog Switches

DG444/DG445

ELECTRICAL CHARACTERISTICS—Dual Supplies (continued)

(V+ = 15V, V- = -15V, VL = 5V, GND = 0V, VINH = 2.4V, VINL = 0.8V, TA = TMIN to TMAX, unless otherwise noted.)

PARAMETER	SYMBOL	CONDITIONS		MIN	TYP (Note 2)	MAX	UNITS
SUPPLY							
Power-Supply Range	V+, V-			±4.5		±20.0	V
Positive Supply Current	I+	All channels on or off, V+ = 16.5V, V- = -16.5V, VIN = 0V or 5V	TA = +25°C	-1	0.001	1	µA
			TA = TMIN to TMAX	-5		5	
Negative Supply Current	I-	All channels on or off, V+ = 16.5V, V- = -16.5V, VIN = 0V or 5V	TA = +25°C	-1	-0.0001	1	µA
			TA = TMIN to TMAX	-5		5	
Logic Supply Current	IL	All channels on or off, V+ = 16.5V, V- = -16.5V, VIN = 0V or 5V	TA = +25°C	-1	0.001	1	µA
			TA = TMIN to TMAX	-5		5	
Ground Current	IGND	All channels on or off, V+ = 16.5V, V- = -16.5V, VIN = 0V or 5V	TA = +25°C	-1	-0.0001	1	µA
			TA = TMIN to TMAX	-5		5	
DYNAMIC							
Turn-On Time	tON	Vs = ±10V, Figure 2	TA = +25°C		150	250	ns
Turn-Off Time	tOFF	DG444, Vs = ±10V, Figure 2	TA = +25°C		90	120	ns
		DG445, Vs = ±10V, Figure 2	TA = +25°C		110	170	ns
Charge Injection (Note 3)	Q	CL = 1nF, VGEN = 0V, RGEN = 0Ω, Figure 3	TA = +25°C		5	10	pC
Off-Isolation Rejection Ratio (Note 6)	OIRR	RL = 50Ω, CL = 5pF, f = 1MHz, Figure 4	TA = +25°C		60		dB
Crosstalk (Note 7)		RL = 50Ω, CL = 5pF, f = 1MHz, Figure 5	TA = +25°C		100		dB
Source-Off Capacitance	CS(OFF)	f = 1MHz, Figure 6	TA = +25°C		4		pF
Drain-Off Capacitance	CD(OFF)	f = 1MHz, Figure 6	TA = +25°C		4		pF
Source-On Capacitance	CS(ON)	f = 1MHz, Figure 7	TA = +25°C		16		pF
Drain-On Capacitance	CD(ON)	f = 1MHz, Figure 7	TA = +25°C		16		pF

Improved, Quad, SPST Analog Switches

ELECTRICAL CHARACTERISTICS—Single Supply

($V_+ = 12V$, $V_- = 0V$, $V_L = 5V$, $GND = 0V$, $V_{INH} = 2.4V$, $V_{INL} = 0.8V$, $T_A = T_{MIN}$ to T_{MAX} , unless otherwise noted.)

PARAMETER	SYMBOL	CONDITIONS	MIN	TYP (Note 2)	MAX	UNITS		
SWITCH								
Analog Signal Range	V_{ANALOG}	(Note 3)	0		12	V		
Drain-Source On-Resistance	$r_{DS(ON)}$	$V_+ = 10.8V$, $V_L = 5.25V$, $V_D = 3V, 8V$, $I_S = -10mA$	$T_A = +25^\circ C$		100	160	Ω	
			$T_A = T_{MIN}$ to T_{MAX}			200		
SUPPLY								
Power-Supply Range	V_+, V_-		10.8		24.0	V		
Power-Supply Current	I_+	All channels on or off, $V_{IN} = 0V$ or $5V$	$T_A = +25^\circ C$		-1	0.001	1	μA
			$T_A = T_{MIN}$ to T_{MAX}		-5		5	
Negative Supply Current	I_-	All channels on or off, $V_{IN} = 0V$ or $5V$	$T_A = +25^\circ C$		-1	-0.0001	1	μA
			$T_A = T_{MIN}$ to T_{MAX}		-5		5	
Logic Supply Current	I_L	All channels on or off, $V_{IN} = 0V$ or $5V$	$T_A = +25^\circ C$		-1	0.001	1	μA
			$T_A = T_{MIN}$ to T_{MAX}		-5		5	
Ground Current	I_{GND}	All channels on or off, $V_{IN} = 0V$ or $5V$	$T_A = +25^\circ C$		-1	-0.0001	1	μA
			$T_A = T_{MIN}$ to T_{MAX}		-5		5	
DYNAMIC								
Turn-On Time	t_{ON}	$V_S = 8V$, Figure 2	$T_A = +25^\circ C$		300	400	ns	
Turn-Off Time	t_{OFF}	$V_S = 8V$, Figure 2	$T_A = +25^\circ C$		60	200	ns	
Charge Injection (Note 3)	Q	$C_L = 1nF$, $V_{GEN} = 0V$, $R_{GEN} = 0\Omega$, Figure 3	$T_A = +25^\circ C$		5	10	pC	

Note 2: Typical values are for **design aid only**, are not guaranteed and are not subject to production testing. The algebraic convention, where the most negative value is a minimum and the most positive value a maximum, is used in this data sheet.

Note 3: Guaranteed by design.

Note 4: On-resistance match between channels and flatness are guaranteed only with bipolar-supply operation. Flatness is defined as the difference between the maximum and the minimum value of on-resistance as measured at the extremes of the specified analog signal range.

Note 5: Leakage parameters $I_{S(OFF)}$, $I_{D(OFF)}$, $I_{D(ON)}$, and $I_{S(ON)}$, are 100% tested at the maximum rated hot temperature and guaranteed at $+25^\circ C$.

Note 6: Off-Isolation Rejection Ratio = $20\log(V_D/V_S)$, V_D = output, V_S = input to off switch.

Note 7: Between any two switches.

Typical Operating Characteristics

($T_A = +25^\circ C$, unless otherwise noted.)

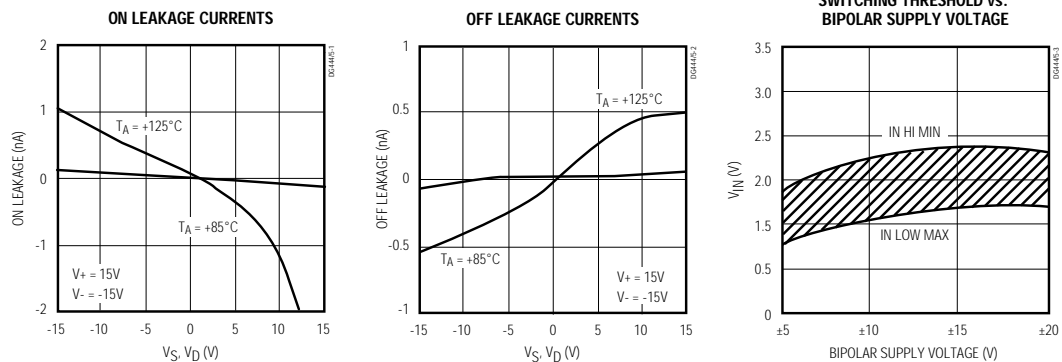

Improved, Quad, SPST Analog Switches

Typical Operating Characteristics (continued)

($T_A = +25^\circ\text{C}$, unless otherwise noted.)

DG444/DG445

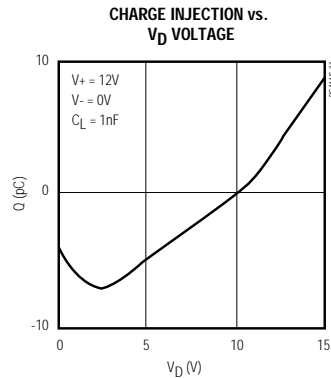
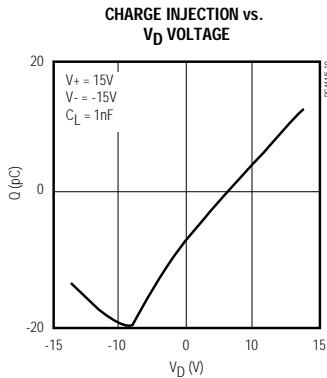
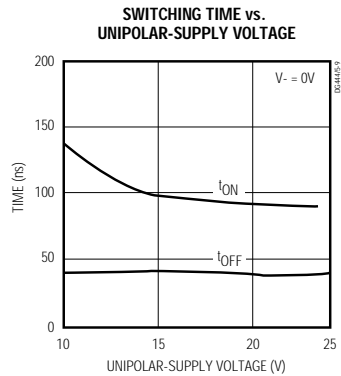
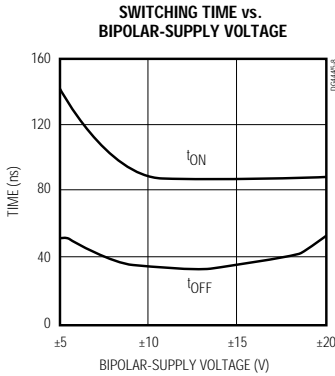
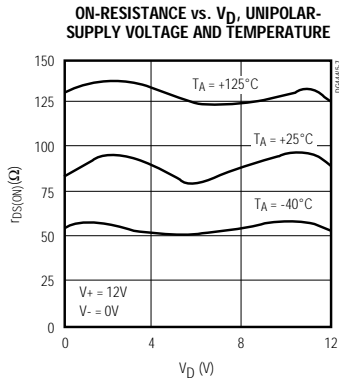
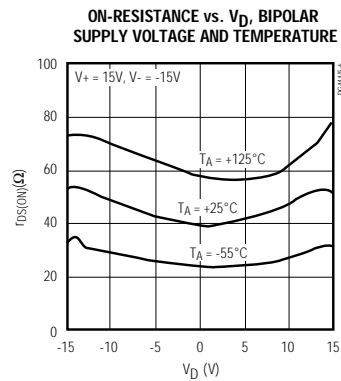
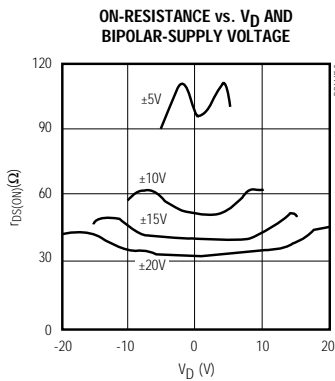
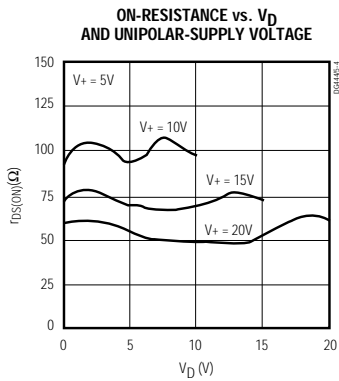

Improved, Quad, SPST Analog Switches

Pin Description

PIN	NAME	FUNCTION
1, 16, 9, 8	IN1-IN4	Logic Control Inputs
2, 15, 10, 7	D1-D4	Drain Outputs
3, 14, 11, 6	S1-S4	Source Outputs
4	V-	Negative Supply-Voltage Input
5	GND	Ground
12	V _L	Logic Supply-Voltage Input
13	V+	Positive Supply-Voltage Input—connected to substrate

Applications Information

General Operation

- Switches are open when power is off.
- IN, D, and S should not exceed V+ or V-, even with the power off.
- Switch leakage is from each analog switch terminal to V+ or V-, not to other switch terminals.

Operation with Supply Voltages Other Than ±15V

Using supply voltages other than ±15V will reduce the analog signal range. The DG444/DG445 switches operate with ±4.5V to ±20V bipolar supplies or with a +10V to +30V single supply; connect V- to 0V when operating with a single supply. Also, all device types can operate with unbalanced supplies such as +24V and -5V. V_L must be connected to +5V to be TTL compatible, or to V+ for CMOS-logic level inputs. The *Typical Operating*

Characteristics graphs show typical on-resistance with ±20V, ±15V, ±10V, and ±5V supplies. (Switching times increase by a factor of two or more for operation at ±5V.)

Overvoltage Protection

Proper power-supply sequencing is recommended for all CMOS devices. Do not exceed the absolute maximum ratings because stresses beyond the listed ratings may cause permanent damage to the devices. Always sequence V+ on first, followed by V_L, V-, and logic inputs. If power-supply sequencing is not possible, add two small, external signal diodes in series with supply pins for overvoltage protection (Figure 1). Adding diodes reduces the analog signal range to 1V below V+ and 1V above V-, but low switch resistance and low leakage characteristics are unaffected. Device operation is unchanged, and the difference between V+ and V- should not exceed +44V.

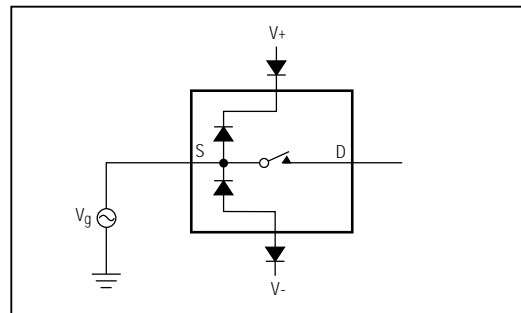

Figure 1. Overvoltage Protection Using External Blocking Diodes

Timing Diagrams/Test Circuits

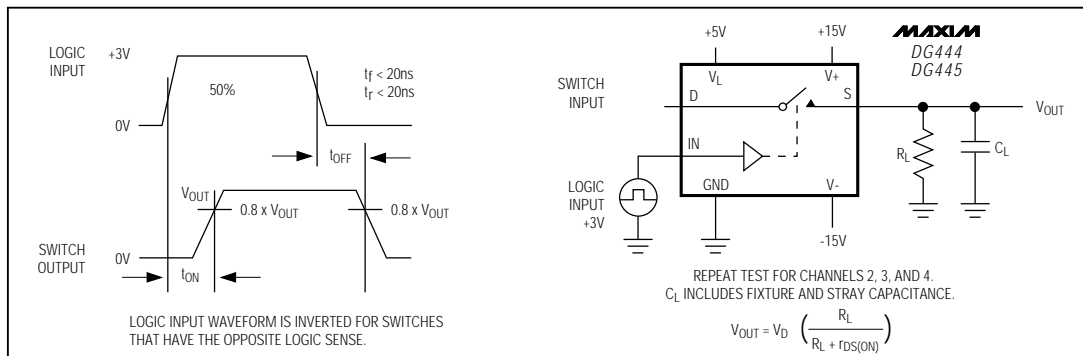

Figure 2. Switching Time

Improved, Quad, SPST Analog Switches

Timing Diagrams/Test Circuits (continued)

DG444/DG445

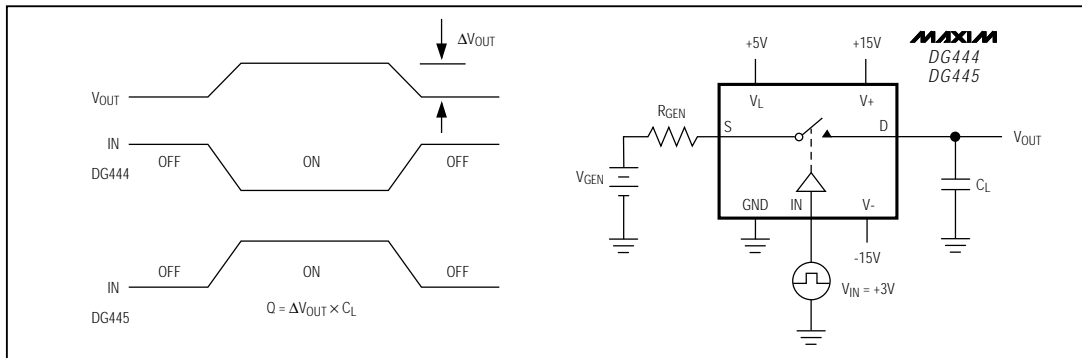

Figure 3. Charge Injection

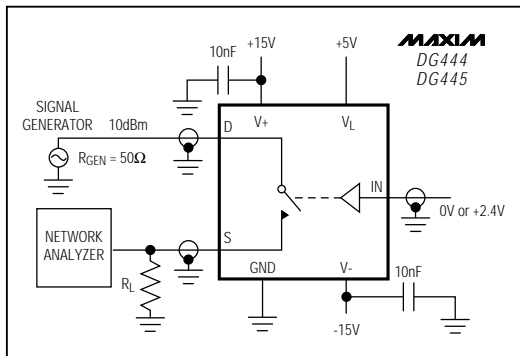

Figure 4. Off-Isolation Rejection Ratio

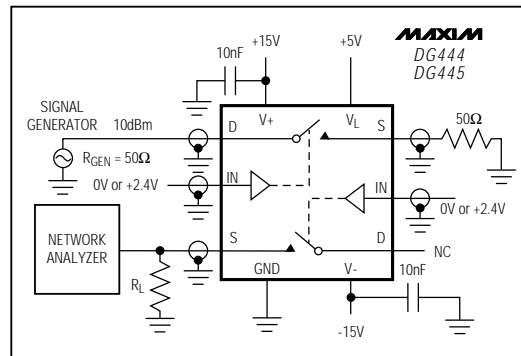

Figure 5. Crosstalk

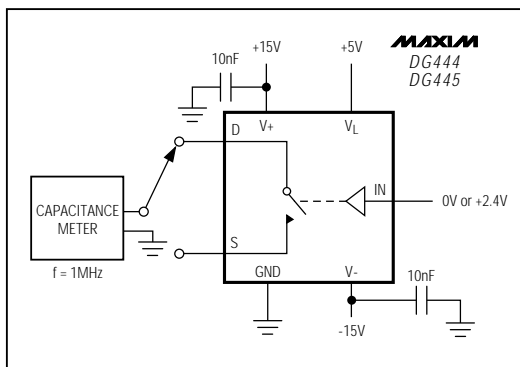

Figure 6. Source/Drain-Off Capacitance

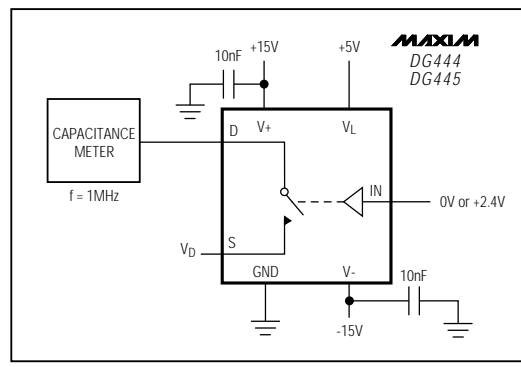

Figure 7. Source/Drain-On Capacitance

Improved, Quad, SPST Analog Switches

Ordering Information (continued)

PART	TEMP. RANGE	PIN-PACKAGE
DG445CJ	0°C to +70°C	16 Plastic DIP
DG445CY	0°C to +70°C	16 Narrow SO
DG445C/D	0°C to +70°C	Dice*
DG445DJ	-40°C to +85°C	16 Plastic DIP
DG445DY	-40°C to +85°C	16 Narrow SO

* Contact factory for dice specifications.

Chip Topography

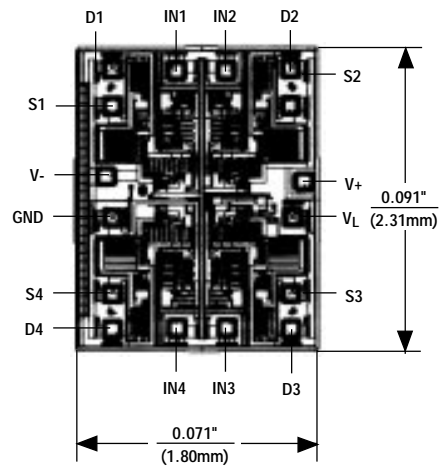

TRANSISTOR COUNT: 126
SUBSTRATE CONNECTED TO V+

Package Information

DIM	INCHES		MILLIMETERS	
	MIN	MAX	MIN	MAX
A	—	0.200	—	5.08
A1	0.015	—	0.38	—
A2	0.125	0.150	3.18	3.81
A3	0.055	0.080	1.40	2.03
B	0.016	0.022	0.41	0.56
B1	0.050	0.065	1.27	1.65
C	0.008	0.012	0.20	0.30
D	0.745	0.765	18.92	19.43
D1	0.005	0.030	0.13	0.76
E	0.300	0.325	7.62	8.26
E1	0.240	0.280	6.10	7.11
e	0.100 BSC		2.54 BSC	
eA	0.300 BSC		7.62 BSC	
eB	—	0.400	—	10.16
L	0.115	0.150	2.92	3.81
α	0°	15°	0°	15°

21-587A

16-PIN PLASTIC DUAL-IN-LINE PACKAGE

Maxim cannot assume responsibility for use of any circuitry other than circuitry entirely embodied in a Maxim product. No circuit patent licenses are implied. Maxim reserves the right to change the circuitry and specifications without notice at any time.

8 Maxim Integrated Products, 120 San Gabriel Drive, Sunnyvale, CA 94086 (408) 737-7600