

MAXIM**3.0V to 5.5V, 1.25Gbps/2.5Gbps
LAN Laser Drivers****General Description**

The MAX3286/MAX3296 series of products are high-speed laser drivers for fiber optic LAN transmitters, optimized for Gigabit Ethernet applications. Each device contains a bias generator, laser modulator, and comprehensive safety features. Automatic power control (APC) adjusts the laser bias current to maintain average optical power at a constant level, regardless of changes in temperature or laser properties. For lasers without a monitor photodiode, these products offer a constant-current mode. The circuit can be configured for use with conventional shortwave (780nm to 850nm) or longwave (1300nm) laser diodes, as well as vertical-cavity surface-emitting lasers (VCSELs).

The MAX3286 series (MAX3286/MAX3287/MAX3288/MAX3289) is optimized for operation at 1.25Gbps, and the MAX3296 series (MAX3296/MAX3297/MAX3298/MAX3299) is optimized for 2.5Gbps operation. Each device can switch 30mA of laser modulation current at the specified data rate. Adjustable temperature compensation is provided to keep the optical extinction ratio within specifications over the operating temperature range. This series of devices is optimized to drive lasers packaged in low-cost TO-46 headers. Deterministic jitter (DJ) for the MAX3286 is typically 22ps, allowing a 72% margin to Gigabit Ethernet DJ specifications.

These laser drivers provide extensive safety features to guarantee single-point fault tolerance. Safety features include dual enable inputs, dual shutdown circuits, and a laser-power monitor. The safety circuit detects faults that could cause dangerous light output levels. A programmable power-on reset pulse initializes the laser driver at start-up.

The MAX3286/MAX3296 are available in a compact, 5mm x 5mm, 32-pin TQFP package or in die form. The MAX3287/MAX3288/MAX3289 and MAX3297/MAX3298/MAX3299 are available in smaller 16-pin TSSOP-EP packages, which are ideal for small form-factor optical modules.

Applications

Gigabit Ethernet Optical Transmitter
Fibre Channel Optical Transmitter
ATM LAN Optical Transmitter

Typical Application Circuits and Selector Guide appear at end of data sheet.

Features

- ◆ 7ps Deterministic Jitter (MAX3296)
22ps Deterministic Jitter (MAX3286)
- ◆ +3.0V to +5.5V Supply Voltage
- ◆ Selectable Laser Pinning (common cathode or common anode) (MAX3286/MAX3296)
- ◆ 30mA Laser Modulation Current
- ◆ Temperature Compensation of Modulation Current
- ◆ Automatic Laser Power Control or Constant Bias Current
- ◆ Integrated Safety Circuits
- ◆ Power-On Reset Signal
- ◆ 16-Pin TSSOP-EP Package Available

Ordering Information

PART	TEMP. RANGE	PIN-PACKAGE
MAX3286CHJ	0°C to +70°C	32 TQFP (5mm x 5mm)
MAX3286C/D	0°C to +70°C	Dice*

Ordering Information continued at end of data sheet.

*Dice are designed to operate from $T_J = 0^\circ\text{C}$ to $+110^\circ\text{C}$, but are tested and guaranteed only at $T_A = +25^\circ\text{C}$.

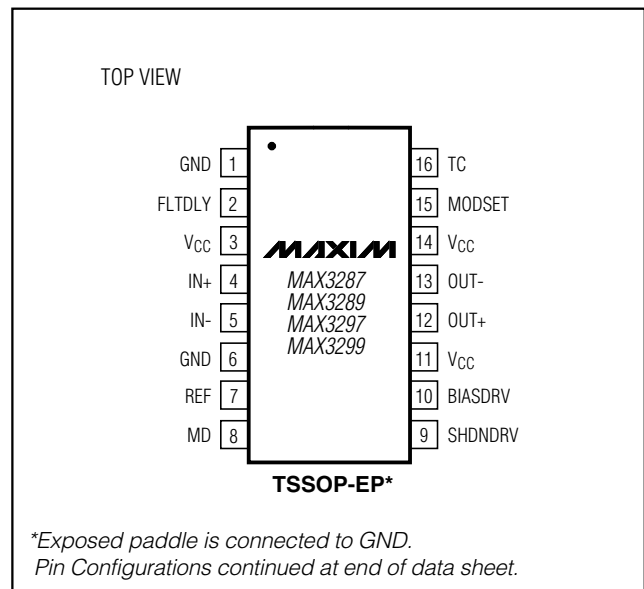
Pin Configurations**MAX3286-MAX3289/MAX3296-MAX3299****MAXIM**

Maxim Integrated Products 1

**For free samples & the latest literature: <http://www.maxim-ic.com>, or phone 1-800-998-8800.
For small orders, phone 1-800-835-8769.**

3.0V to 5.5V, 1.25Gbps/2.5Gbps LAN Laser Drivers

ABSOLUTE MAXIMUM RATINGS

Supply Voltage at V_{CC}-0.5V to +7.0V
 Voltage at EN, EN, POR_{DLY}, FLTDLY, LV, IN+, IN-, REF, POL, POL, MD, MON, BIASDRV, MODSET, TC.....-0.5V to (V_{CC} + 0.5V)
 Voltage at OUT+, OUT-.....(V_{CC} - 2V) to (V_{CC} + 2V)
 Current into FAULT, FAULT, POR, SHDNDRV.....-1mA to +25mA
 Current into OUT+, OUT-......60mA

Continuous Power Dissipation (T_A = +70°C)
 32-Pin TQFP (derate 14.3mW/°C)1100mW
 16-Pin TSSOP (derate 27mW/°C).....2162mW
 Operating Temperature Range.....0°C to +70°C
 Operating Junction Temperature Range.....0°C to +150°C
 Processing Temperature (die)+400°C
 Storage Temperature Range-55°C to +150°C
 Lead Temperature (soldering, 10s)+300°C

Stresses beyond those listed under "Absolute Maximum Ratings" may cause permanent damage to the device. These are stress ratings only, and functional operation of the device at these or any other conditions beyond those indicated in the operational sections of the specifications is not implied. Exposure to absolute maximum rating conditions for extended periods may affect device reliability.

ELECTRICAL CHARACTERISTICS

(V_{CC} = +3.0V to +5.5V, T_A = 0°C to +70°C, unless otherwise noted. Typical values are at V_{CC} = +3.3V and T_A = +25°C, R_{TC} = open; see Figure 1a.)

PARAMETER	SYMBOL	CONDITIONS	MIN	TYP	MAX	UNITS
Supply Current	I _{CC}	Figure 1a, R _{MOD} = 1.82kΩ		52	75	mA
Data Input Voltage Swing	V _{ID}	Total differential signal, peak-peak, Figure 1a	200		1660	mV
TTL Input Current		0 ≤ V _{PIN} ≤ V _{CC}	-100		100	μA
TTL Input High Voltage	V _{IH}		2.0			V
TTL Input Low Voltage	V _{IL}				0.8	V
FAULT, FAULT Output High Voltage	V _{OH}	I _{OH} = -100μA	2.4			V
FAULT, FAULT Output Low Voltage	V _{OL}	I _{OL} = 1mA			0.4	V
BIAS GENERATOR (Note 1)						
BIASDRV Current, Shutdown		EN = GND	-1		1	μA
BIASDRV Current Sink		FAULT = low, V _{BIASDRV} ≥ 0.6V	0.8			mA
BIASDRV Current Source		FAULT = low, V _{BIASDRV} ≤ V _{CC} - 1V	0.8			
REF Voltage		I _{REF} ≤ 2mA, MON = V _{CC}	2.45	2.65	2.85	V
MD Nominal Voltage	V _{MD}	APC loop is closed	1.55	1.7	1.85	V
MD Voltage During Fault		Common-cathode configuration		0.4	1.2	V
		Common-anode configuration	2	V _{CC} - 0.8		
MD Input Current		Normal operation (FAULT = low)	-2	0.16	2	μA
MON Input Current		V _{MON} = V _{CC}		0.44	6	μA
POWER-ON RESET						
POR Threshold		LV = GND	3.9		4.5	V
		LV = open	2.65		3.0	
POR Hysteresis				150		mV
FAULT DETECTION						
REF Fault Threshold					2.95	V
MD High Fault Threshold			V _{MD} + 5%	V _{MD} + 20%		
MD Low Fault Threshold			V _{MD} - 20%	V _{MD} - 5%		
MON Fault Threshold		MAX3286/MAX3288/MAX3296/MAX3298	V _{CC} - 600	V _{CC} - 480		mV
MODSET, TC Fault Threshold				0.8		V

3.0V to 5.5V, 1.25Gbps/2.5Gbps LAN Laser Drivers

MAX3286-MAX3289/MAX3296-MAX3299

ELECTRICAL CHARACTERISTICS (continued)

(V_{CC} = +3.0V to +5.5V, T_A = 0°C to +70°C, unless otherwise noted. Typical values are at V_{CC} = +3.3V and T_A = +25°C, R_{TC} = open; see Figure 1a.)

PARAMETER	SYMBOL	CONDITIONS	MIN	TYP	MAX	UNITS
SHUTDOWN						
Voltage at SHDNDRV		I _{SHDNDRV} = 10μA, FAULT asserted	V _{CC} - 0.4		V	
		I _{SHDNDRV} = 15mA, FAULT not asserted	0	V _{CC} - 1.2		
		I _{SHDNDRV} = 1mA, FAULT not asserted	0	V _{CC} - 2.4		
LASER MODULATOR						
Data Rate		MAX3286 series	1.25		Gbps	
		MAX3296 series	2.5			
Minimum Laser Modulation Current			2			mA
Maximum Laser Modulation Current		R _L ≤ 25Ω	30			mA
Tolerance of Modulation Current		R _{MOD} = 1.9kΩ (i _{MOD} = 30mA)	-10	10		%
		R _{MOD} = 13kΩ (i _{MOD} = 5mA)	-15	15		
Modulation-Current Edge Speed		20% to 80%	MAX3286 series	130	220	ps
			MAX3296 series	90	150	
Deterministic Jitter (Note 2)		MAX3286 series	R _{MOD} = 13kΩ (i _{MOD} = 5mA)	46	65	ps
			R _{MOD} = 4.1kΩ (i _{MOD} = 15mA)	29	45	
			R _{MOD} = 1.9kΩ (i _{MOD} = 30mA)	22	35	
		MAX3296 series	R _{MOD} = 13kΩ (i _{MOD} = 5mA)	14	35	
			R _{MOD} = 4.1kΩ (i _{MOD} = 15mA)	8	22	
			R _{MOD} = 1.9kΩ (i _{MOD} = 30mA)	7	20	
Random Jitter, RMS (Note 3)		MAX3286 series	2		8	ps
		MAX3296 series	2		4	
Shutdown Modulation Current			15		200	μA
Modulation-Current Temperature Coefficient		Temp _{CO} = max, R _{MOD} = open; Figure 5	4000		ppm/°C	
		Temp _{CO} = min, R _{TC} = open; Figure 5	50			
Differential Input Resistance			620	800	980	Ω
Output Resistance		Single ended	42	50	58	Ω
Input Bias Voltage			V _{CC} - 0.3			V
LASER SAFETY CIRCUIT						
POR Delay	t _{PORDLY}	PORDLY = open	0.3	1.25		μs
		C _{PORDLY} = 0.01μF, MAX3286/MAX3296 only	3	5.5		ms
Fault Time	t _{FAULT}	(Note 4)	22			μs
Glitch Rejection at MD			10	20		μs

3.0V to 5.5V, 1.25Gbps/2.5Gbps LAN Laser Drivers

ELECTRICAL CHARACTERISTICS (continued)

(V_{CC} = +3.0V to +5.5V, T_A = 0°C to +70°C, unless otherwise noted. Typical values are at V_{CC} = +3.3V and T_A = +25°C, R_{TC} = open; see Figure 1a.)

PARAMETER	SYMBOL	CONDITIONS	MIN	TYP	MAX	UNITS
FLTDLY Duration	t _{FLTDLY}	C _{FLTDLY} = 0	0.2	1		μs
		C _{FLTDLY} = 270pF	100	140		
EN or $\overline{\text{EN}}$ Minimum Pulse Width Required to Reset a Latched Fault	t _{EN_RESET}	MAX3286/MAX3296 only, Figure 1b		6	10	ns
FAULT Reset After EN, $\overline{\text{EN}}$, or POR Transition	t _{RESET}	MAX3286/MAX3296 only, Figure 1b		1	2	μs
SHDNDRV Asserted After EN = low or $\overline{\text{EN}}$ = high	t _{SHUTDN}	MAX3286/MAX3296 only, Figure 1b		3.5	5.5	μs

Note 1: “Common-anode configuration” refers to a configuration where POL = GND, $\overline{\text{POL}}$ = V_{CC}, and an NPN device is used to set the laser bias current. “Common-cathode configuration” refers to a configuration where POL = V_{CC}, $\overline{\text{POL}}$ = GND, and a PNP device is used to set the laser bias current.

Note 2: Deterministic jitter measured with a repeating K28.5 bit pattern 00111110101100000101. Deterministic jitter is the peak-to-peak deviation from the ideal time crossings per ANSI X3.230, Annex A.

Note 3: For Fibre Channel and Gigabit Ethernet applications, the peak-to-peak random jitter is 14.1 times the RMS jitter.

Note 4: Delay from a fault on MD until FAULT is asserted high.

Typical Operating Characteristics

(T_A = +25°C, unless otherwise noted.)

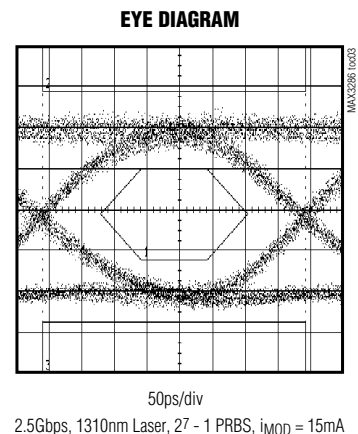
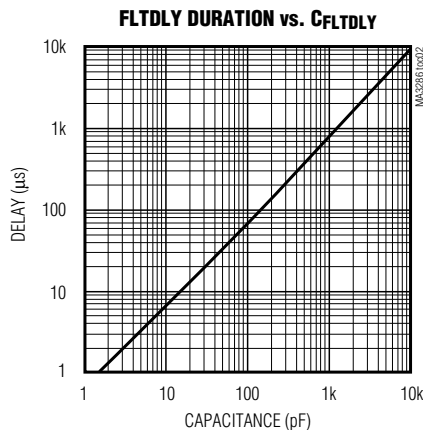
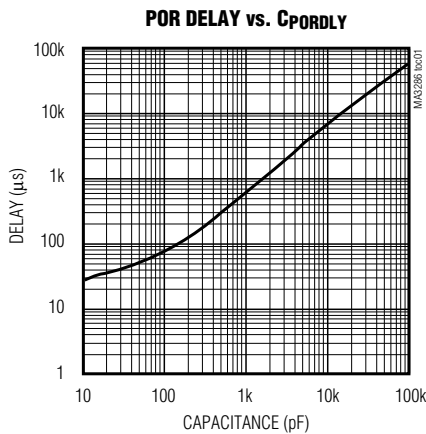

3.0V to 5.5V, 1.25Gbps/2.5Gbps LAN Laser Drivers

Typical Operating Characteristics (continued)

(T_A = +25°C, unless otherwise noted.)

**EN STARTUP
(COMMON-ANODE CONFIGURATION)**

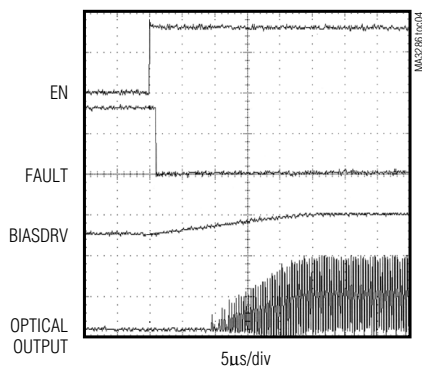

MD SHUTDOWN

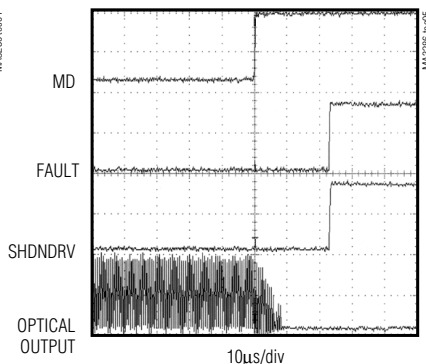

EYE DIAGRAM

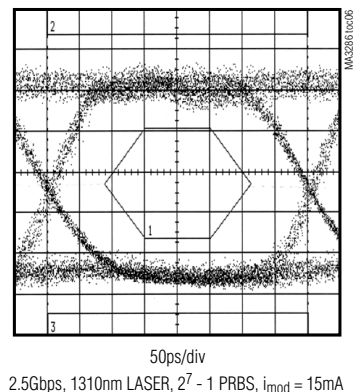

Pin Description

PIN			NAME	FUNCTION
MAX3286 MAX3296	MAX3287 MAX3297 MAX3289 MAX3299	MAX3288 MAX3298		
1	—	—	FAULT	Inverting Fault Indicator. See Table 1.
2, 16	—	—	N.C.	No Connect
3	—	—	FAULT	Noninverting Fault Indicator. See Table 1.
4	—	—	POR	Power-On Reset. POR is a TTL-compatible output. See Figure 14.
5, 14, 22, 30	1, 6	1, 6	GND	Ground
6	—	—	EN	Enable TTL Input. Laser output is enabled only when EN is high and EN is low. If EN is left unconnected, the laser is disabled.
7	—	—	EN	Inverting Enable TTL Input. Laser output is enabled only when EN is low or grounded and EN is high. If EN is left unconnected, the laser is disabled.
8	—	—	PORDLY	Power-On Reset Delay. To extend the delay for the power-on reset circuit, connect a capacitor to PORDLY. See <i>Design Procedure</i> .
9	2	2	FLTDLY	Fault Delay Input. Determines the delay of the FAULT and FAULT outputs. A capacitor attached to FLTDLY ensures proper start-up. (See <i>Typical Operating Characteristics</i> .) FLTDLY = GND: holds FAULT low and FAULT high. When FLTDLY = GND, EN = high, EN = low, and V _{CC} is within the operational range, the safety circuitry is inactive.
10	—	—	LV	Low-Voltage Operation. Connect to GND for 4.5V to 5.5V operation. Leave open for 3.0V to 5.5V operation.
11, 25, 26, 29	3, 11, 14	3, 11, 14	V _{CC}	Supply Voltage

3.0V to 5.5V, 1.25Gbps/2.5Gbps LAN Laser Drivers

Pin Description (continued)

PIN			NAME	FUNCTION
MAX3286 MAX3296	MAX3287 MAX3297 MAX3289 MAX3299	MAX3288 MAX3298		
12	4	4	IN+	Noninverting Data Input
13	5	5	IN-	Inverting Data Input
15	7	7	REF	Reference Voltage. A resistor connected at REF to MD determines the laser power when APC is used with common-cathode lasers.
17	—	—	POL	Polarity Input. POL is used for programming the laser-pinning polarity. (Table 4)
18	—	—	$\overline{\text{POL}}$	Inverting Polarity Input. $\overline{\text{POL}}$ is used for programming the laser-pinning polarity (Table 4)
19	—	—	I.C.	Internally Connected. Do not connect.
20	8	8	MD	Monitor Diode Connection. MD is used for automatic power control.
21	—	9	MON	Laser Bias Current Monitor. Used for programming laser bias current in VCSEL applications.
23	9	—	SHDN-DRV	Shutdown Driver Output. Provides a redundant laser shutdown.
24	10	10	BIASDRV	Bias-Controlling Transistor Driver. Connects to the base of an external PNP or NPN transistor.
27	12	12	OUT+	Modulation-Current Output. See <i>Typical Application Circuits</i> .
28	13	13	OUT-	Modulation-Current Output. See <i>Typical Application Circuits</i> .
31	15	15	MODSET	Modulation-Current Set. The resistor at MODSET programs the temperature-stable component of the laser modulation current.
32	16	16	TC	Temperature-Compensation Set. The resistor at TC programs the temperature-increasing component of the laser modulation current.
—	EP	EP	Exposed Paddle	Ground. This must be soldered to the circuit board ground for proper thermal performance. See <i>Layout Considerations</i> .

Table 1. Typical Fault Conditions

PIN	FAULT CONDITION
V _{CC}	LV = open and V _{CC} < 3V; LV = GND and V _{CC} < 4.5V
REF	V _{REF} > 2.95V
POL and $\overline{\text{POL}}$	POL = $\overline{\text{POL}}$
MON	V _{MON} < V _{CC} - 540mV
MD	V _{MD} > 1.15 · V _{MD(nom)} , V _{MD} < 0.85 · V _{MD(nom)}
EN and $\overline{\text{EN}}$	EN = low or open, $\overline{\text{EN}}$ = high or open
MODSET and TC	V _{MODSET} and V _{TC} ≤ 0.8V

Table 2. LV Operating Range

LV	OPERATING VOLTAGE RANGE (V)
Open	>3.0
Grounded	>4.5

3.0V to 5.5V, 1.25Gbps/2.5Gbps LAN Laser Drivers

MAX3286-MAX3289/MAX3296-MAX3299

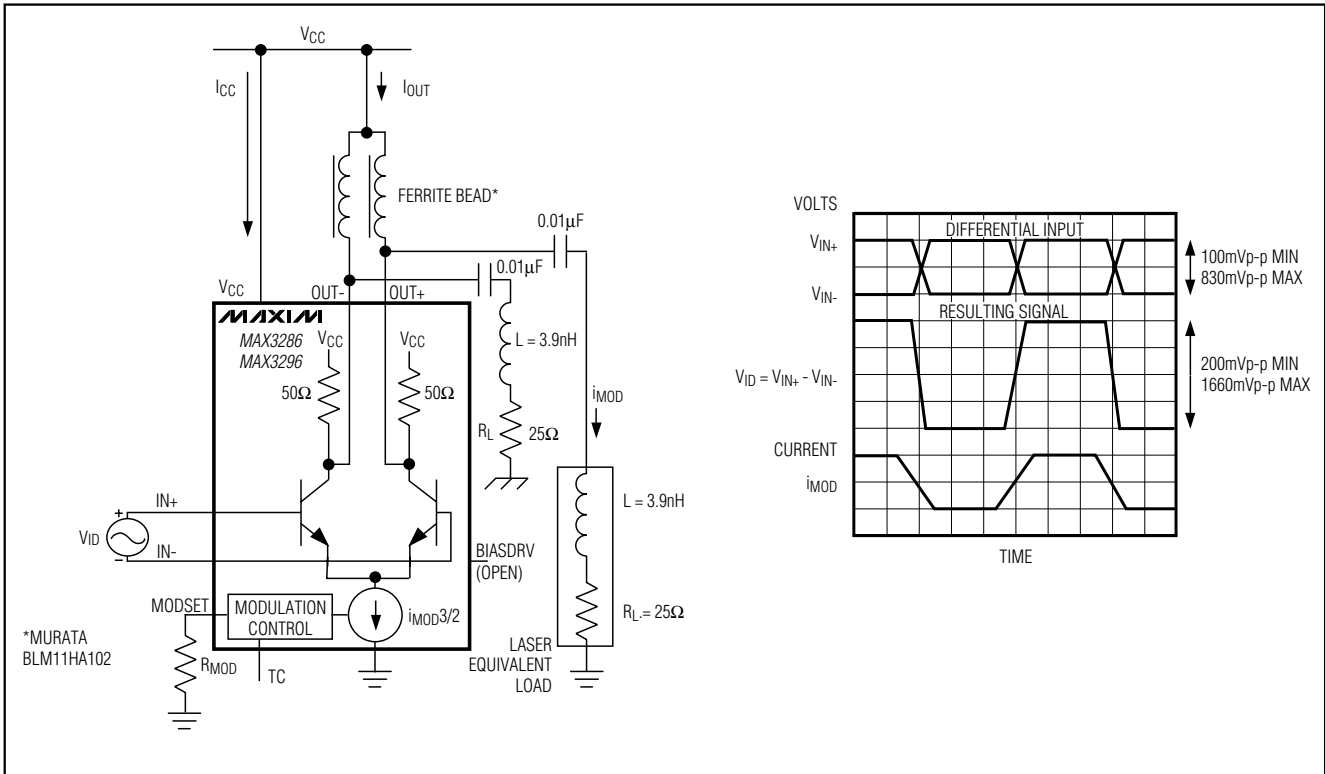

Figure 1a. Output Load for AC Specification

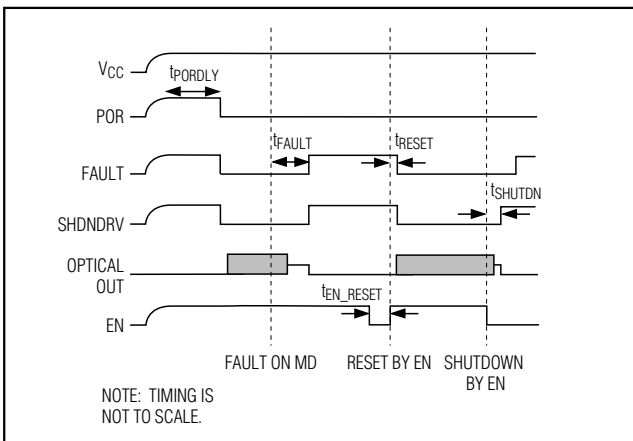

Figure 1b. Fault Timing

Detailed Description

The MAX3286/MAX3296 series of laser drivers contain a bias generator with automatic power control (APC), laser modulator, power-on reset (POR) circuit, and safety circuitry (Figures 2a and 2b).

Bias Generator

Figure 3 shows the bias generator circuitry containing a power-control amplifier, controlled reference voltage, smooth-start circuit, and window comparator. The bias generator combined with an external PNP or NPN transistor provides DC laser current to bias the laser in a light-emitting state. When there is a monitor diode (MD) in the laser package, the APC circuitry adjusts the laser-bias current to maintain average power over tem-

3.0V to 5.5V, 1.25Gbps/2.5Gbps LAN Laser Drivers

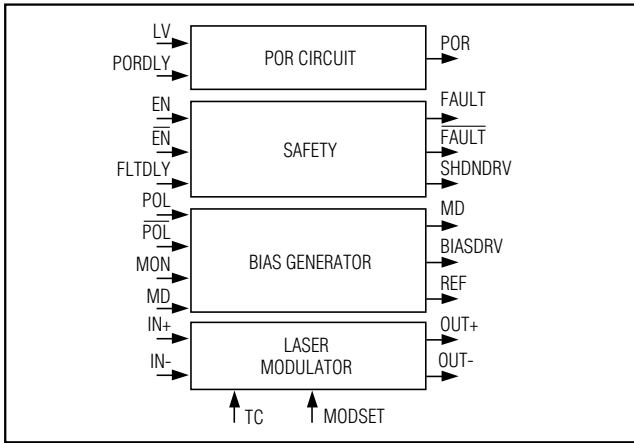

Figure 2a. Simplified Laser Driver Functional Diagram

perature and changing laser properties. The MD input is connected to the anode or cathode of a monitor photodiode or to a resistor-divider, depending on the specific application circuit. Three application circuits are supported: common-cathode laser with photodiode, common-cathode laser without photodiode, and common-anode laser with photodiode (as shown in the *Design Procedure*). The POL and POL inputs determine the laser pinning (common cathode, common anode) (Table 4).

The smooth-start circuitry prevents current spikes to the laser during power-up or enable; this ensures compliance with safety requirements and extends the life of the laser.

The power-control amplifier drives an external transistor to control the laser bias current. In a fault condition, the power-control amplifier's output is disabled (high

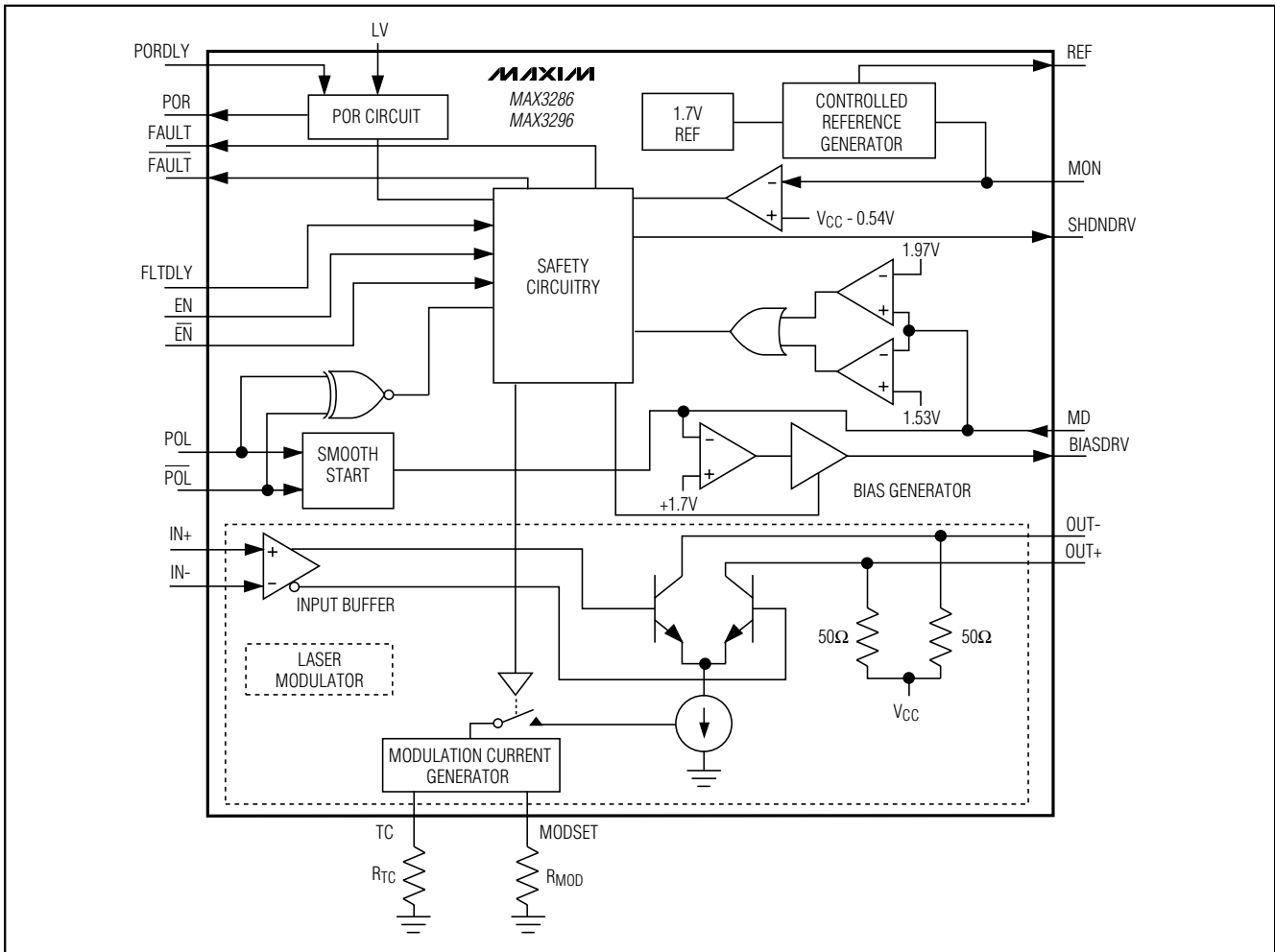

Figure 2b. Laser Driver Functional Diagram

3.0V to 5.5V, 1.25Gbps/2.5Gbps LAN Laser Drivers

MAX3286-MAX3289/MAX3296-MAX3299

impedance). This ensures that the PNP or NPN transistor is turned off, removing the laser-bias current. (See *Applications Information*.)

The REF pin provides a controlled reference voltage dependent upon the voltage at MON. The voltage at REF is $V_{REF} = 2.65 - 2.25(V_{CC} - V_{MON})$. A resistor connected at REF determines the laser power when APC is used with common-cathode lasers. See the *Design Procedure* for setting the laser power.

Modulation Circuitry

The modulator circuitry consists of an input buffer, current generator, and high-speed current switch (Figure 4). The modulator drives up to 30mA of modulation current into a 25Ω load.

Many of the modulator performance specifications depend on the total modulator current (I_{OUT}) (Figure 1a). To ensure good driver performance, the voltage at OUT+ and OUT- must not be less than $V_{CC} - 1V$.

The amplitude of the modulation current is set with resistors at the MODSET and TC (temperature coefficient) pins. The resistor at MODSET (R_{MOD}) programs the temperature-stable portion of modulation current, while the resistor at TC (R_{TC}) programs the temperature-increasing portion of the modulation current. Figure 5 shows modulation current as a function of temperature for two extremes: RTC is open (the modulation current has zero temperature coefficient) and R_{MOD} is open (the modulation temperature coefficient is 4000ppm). Intermediate tempco values of modulation current can be obtained as described in the *Design Procedure*.

Safety Circuitry

The laser driver can be used with two popular safety systems. APC maintains laser safety using local feedback. Safety features monitor laser driver operation and force a shutdown if a fault is detected. The shutdown condition is latched until reset by a toggle of EN, EN, or power.

Another safety system, Open Fiber Control (OFC), uses safety interlocks to prevent eye hazards. To accommodate the OFC standard, the MAX3286/MAX3296 series provide dual enable inputs and dual fault outputs.

The safety circuitry contains fault detection, dual enable inputs, latched fault outputs, and a pulse generator (Figure 6).

Safety circuitry monitors the APC circuit to detect unsafe levels of laser emission during single-point failures. A single-point failure can be a short to V_{CC} or GND, or between any two IC pins.

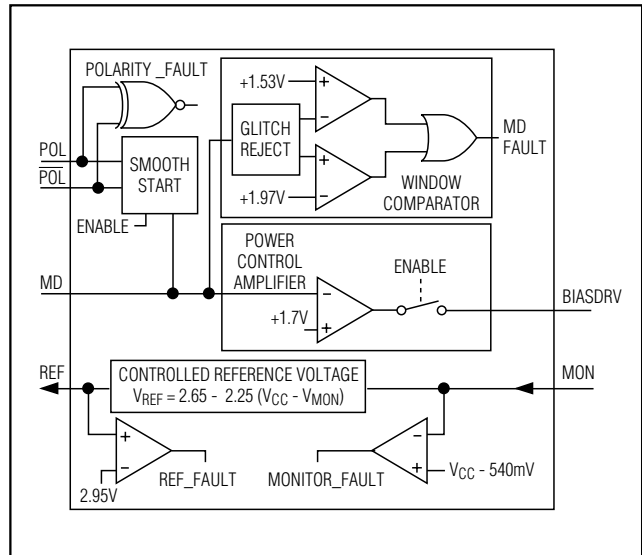

Figure 3. Bias Generator Circuitry

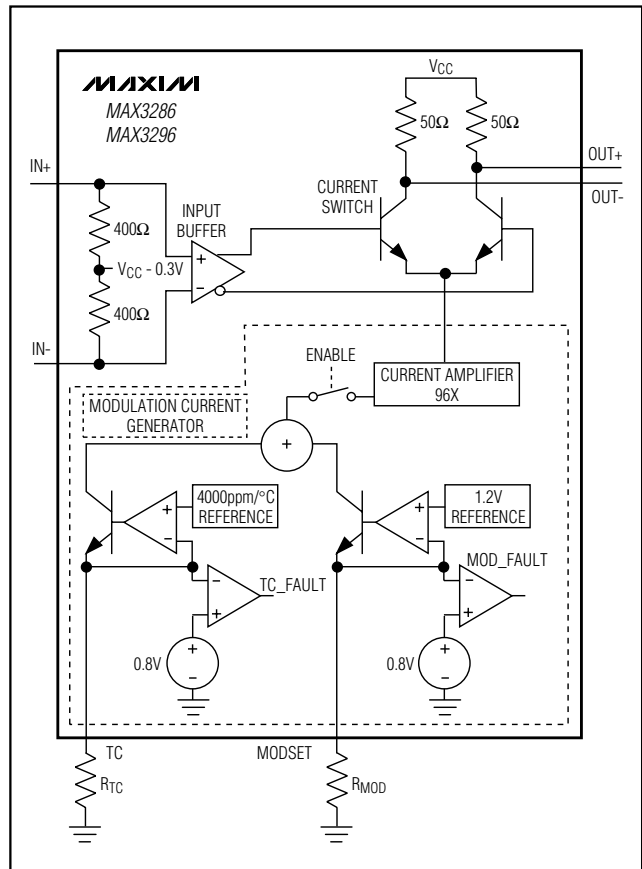

Figure 4. Laser Modulator Circuitry

3.0V to 5.5V, 1.25Gbps/2.5Gbps LAN Laser Drivers

Pulse Generator

During start-up, the laser is not emitting light and the APC loop is not closed, triggering a fault signal. To allow start-up, an internal fault-delay pulse disables the safety system for a programmable period of time, allowing the driver to begin operation. The length of the pulse is determined by the capacitor connected at FLTDLY and should be set 5 to 10 times longer than the APC time constant. The internal safety features can be disabled by connecting FLTDLY to GND. Note that EN must be high, $\overline{\text{EN}}$ must be low, and VCC must be in the operational range for laser operation.

Fault Detection

The MAX3286/MAX3296 series have extensive and comprehensive fault-detection features. All critical

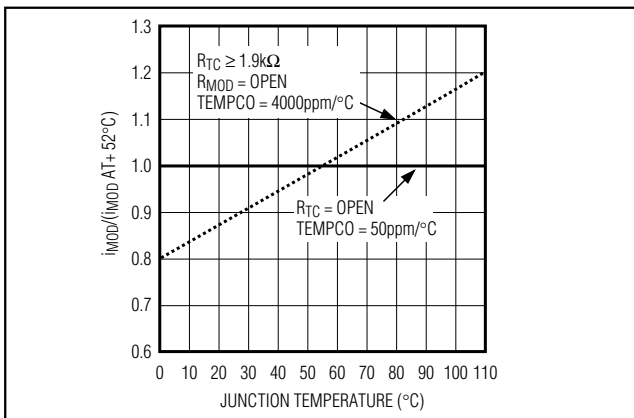

Figure 5. Modulation Current vs. Temperature for Maximum and Minimum Temperature Coefficient

nodes are monitored for safety faults, and any node voltage that differs significantly from its expected value results in a fault (Table 1). When a fault condition is detected, the laser is shut down. See *Applications Information* for more information on laser safety.

Shutdown

The laser drivers offer dual redundant bias shutdown mechanisms. The SHDNDRV output drives an optional external MOSFET semiconductor. The bias and modulation drivers have separate, internal disable signals.

Latched Fault Output

Two complementary FAULT outputs are provided with the MAX3286/MAX3296 series. In the event of a fault, these outputs latch until one of three events occurs:

- 1) The power is switched off, then on.
- 2) EN is switched low, then high.
- 3) $\overline{\text{EN}}$ is switched to high, then low.

Power-On Reset (POR)

Figure 7 shows the power-on reset (POR) circuit for the MAX3286/MAX3296 series devices. A POR signal asserts low when VCC is in the operating range. The voltage operating range is determined by the LV pin, as shown in Table 2. POR contains an internal delay to reject noise on VCC during power-on or hot-plugging. The delay can be extended by adding capacitance to the PORDLY pin. The POR comparator includes hysteresis to improve noise rejection. The laser driver is shut down while VCC is out of the operating range.

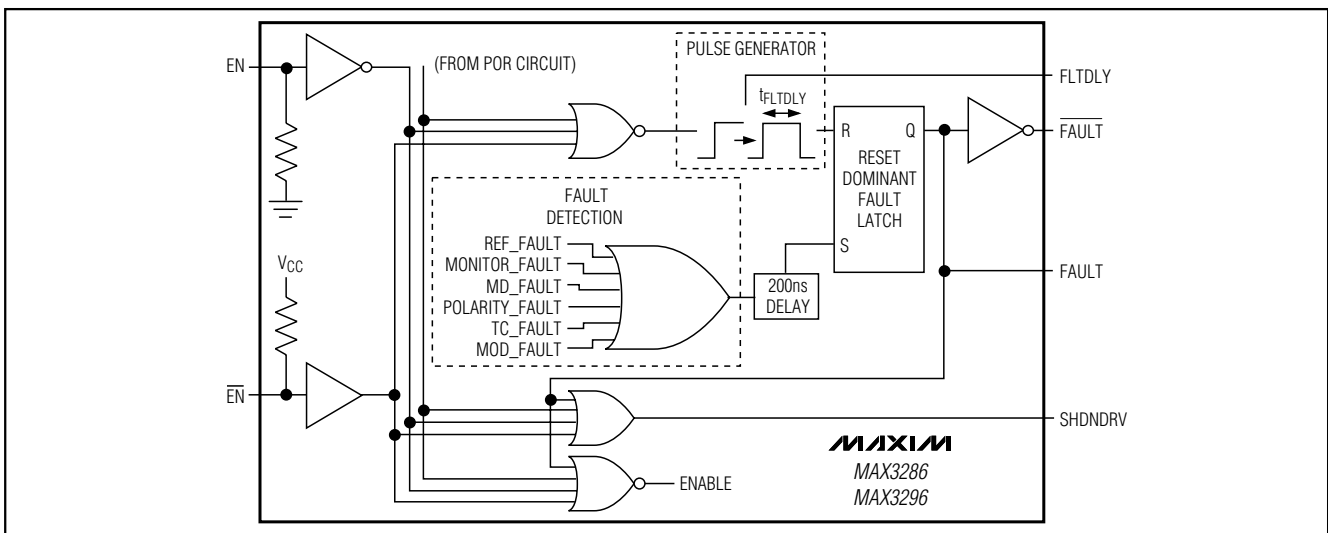

Figure 6. Simplified Safety Circuit Schematic

3.0V to 5.5V, 1.25Gbps/2.5Gbps LAN Laser Drivers

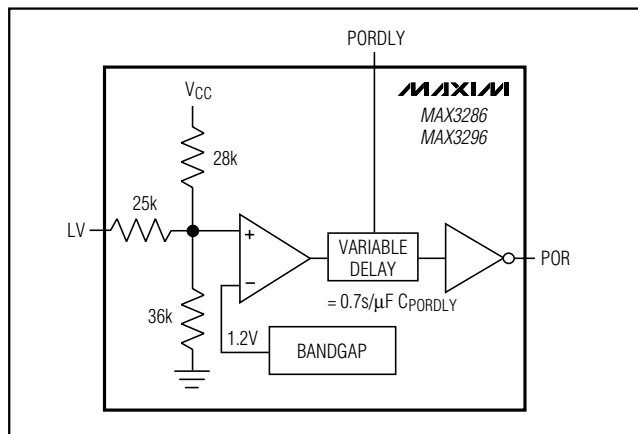

Figure 7. Power-On Reset Circuit

Design Procedure

Select Laser

Select a communications-grade laser with a rise time of 260ps or better for 1.25Gbps, or 130ps or better for 2.5Gbps applications. To obtain the MAX3286/MAX3296's AC specifications, the instantaneous output voltage at OUT+ must remain above $V_{CC} - 1V$ at all times. Select a high-efficiency laser that requires low modulation current and generates low-voltage swing at OUT+. Laser package inductance can be reduced by trimming the leads. Typical package leads have inductance of 25nH/in (1nH/mm), this inductance causes a larger voltage swing across the laser. A compensation filter network can also be used to reduce ringing, edge speed, and voltage swing.

Programming the Modulation Current

Resistors at the MODSET and TC pins set the amplitude of the modulation current. The resistor R_{MOD} sets the temperature-stable portion of the modulation current while the resistor R_{TC} sets the temperature-increasing portion of the modulation current.

To determine the appropriate temperature coefficient from the slope efficiency (α) of the laser, use the following equation:

$$\text{Laser Tempco} = \frac{\alpha_{70} - \alpha_{25}}{\alpha_{25}(70^{\circ}\text{C} - 25^{\circ}\text{C})} \cdot 10^6 \text{ [ppm/}^{\circ}\text{C]}$$

where α is the slope of the laser output power to the laser current.

For example, suppose a laser has a slope efficiency α_{25} of 0.021mW/mA at +25°C, which reduces to

0.018mW/mA at +70°C. Using the above equation will produce a laser tempco of -3175ppm/°C.

To obtain the desired modulation current and tempco for the device, the following two equations can be used to determine the required values of R_{MOD} and R_{TC} :

$$R_{TC} = \frac{0.21}{\text{Tempco}(i_{MOD})} - 250\Omega$$

$$R_{MOD} = \frac{(R_{TC} + 250\Omega)52 \cdot \text{Tempco}}{(0.19 - 48 \cdot \text{Tempco})} - 250\Omega$$

where $\text{Tempco} = -\text{Laser Tempco}$.

Figure 8a shows a family of curves derived from these equations. The straight diagonal lines depict constant tempcos. The curved lines represent constant modulation currents. If no temperature compensation is desired, Figure 8b displays a series of curves that show laser modulation current with respect to R_{MOD} for different loads.

The following useful equations were used to derive Figure 8a and the equations at the beginning of this section. The first assumes $R_L = 25\Omega$.

$$i_{MOD} = 51 \cdot \left[\frac{1.15}{R_{MOD} + 250\Omega} + \frac{1.06}{R_{TC} + 250\Omega} \cdot \frac{1}{(1 + 4.0 \cdot 10^{-3}(T - 25^{\circ}\text{C}))} \right] \text{ [A]}$$

$$i_{MOD}(70^{\circ}\text{C}) = i_{MOD}(25^{\circ}\text{C}) + i_{MOD}(25^{\circ}\text{C}) (\text{TEMPCO})(70^{\circ}\text{C} - 25^{\circ}\text{C}) \text{ [A]}$$

Programming the Bias Current/APC

Three application circuits are described below: common-cathode laser with photodiode, common-cathode laser without photodiode, and common-anode laser with photodiode. The POL and $\overline{\text{POL}}$ inputs determine the laser pinning (common cathode, common anode) and affect the smooth-start circuits (Table 4).

Common Cathode with Photodiode (Optical Feedback)

In the common-cathode with photodiode configuration, a servo control loop is formed by external PNP Q1, the laser diode, the monitor diode, RSET, and the power-control amplifier (Figure 9). The voltage at MD is stabilized to 1.7V. The monitor photodiode current (I_D) is set by $(V_{REF} - V_{MD}) / R_{SET} = 0.95 / R_{SET}$. Determine the desired monitor current (I_D), then select $R_{SET} = 0.95 / I_D$.

3.0V to 5.5V, 1.25Gbps/2.5Gbps LAN Laser Drivers

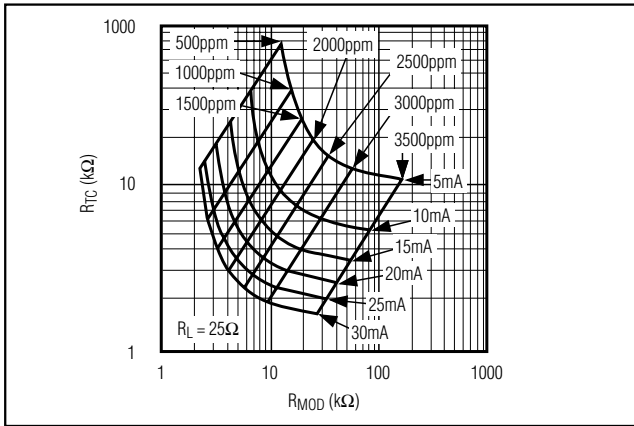

Figure 8a. R_{TC} vs. R_{MOD} for Various Conditions

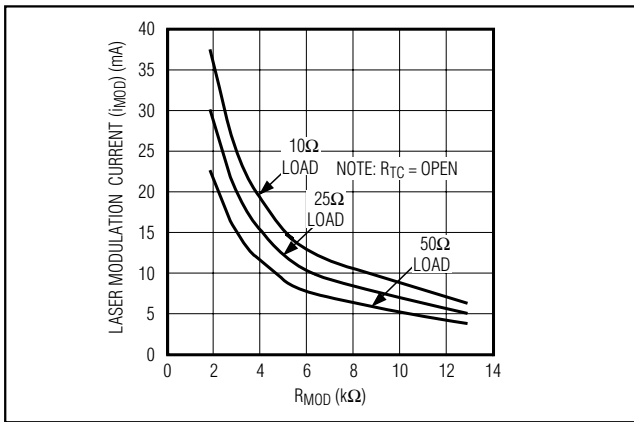

Figure 8b. Laser-Modulation Current vs. R_{MOD}

The APC loop is compensated by CBIASDRV. A capacitor must be placed from BIASDRV to V_{CC} to ensure low-noise operation and to reject power-supply noise. The time constant governs how quickly the laser bias current reacts to a change in the average total laser current ($I_{BIASDRV} + i_{MOD}$). A capacitance of 0.1 μ F is sufficient to obtain a loop time constant in excess of 1 μ s, provided that RDEG is chosen appropriately. Resistor RDEG may be necessary to ensure the APC loop's stability when low bias currents are desired.

The voltage across RDEG should not be any larger than 250mV at maximum bias current.

The discrete components used with the common cathode with photodiode configuration are as follows:

$$R_{SET} = 0.88 / I_D$$

$$C_{BIASDRV} = 0.1\mu F \text{ (typ)}$$

Table 3. R_{TC} and R_{MOD} Selection Table

TEMPCO (ppm/°C)	$i_{MOD} = 30\text{mA}$		$i_{MOD} = 15\text{mA}$		$i_{MOD} = 5\text{mA}$	
	R_{MOD} (kΩ)	R_{TC} (kΩ)	R_{MOD} (kΩ)	R_{TC} (kΩ)	R_{MOD} (kΩ)	R_{TC} (kΩ)
3500	26.7	1.69	53.6	3.65	162	11.5
3000	9.53	2.0	18.7	4.32	57.6	13.3
2500	5.76	2.49	11.3	5.23	34.8	16.2
2000	4.12	3.16	8.06	6.49	24.9	20.0
1500	3.24	4.32	6.19	8.87	19.1	26.7
1000	2.67	6.49	5.11	13.3	15.8	40.2
500	2.26	13.3	4.22	26.7	13.3	80.6

Table 4. POL Pin Setup for Each Laser Configuration Type

DEVICE	POL	$\overline{\text{POL}}$	DESCRIPTION	LASER PINNING
MAX3286/MAX3296	VCC	GND	Common cathode with photodiode	
MAX3287/MAX3297	—	—		
MAX3286/MAX3296	VCC	GND	Common cathode without photodiode	
MAX3288/MAX3298	—	—		
MAX3286/MAX3296	GND	VCC	Common anode with photodiode	
MAX3289/MAX3299	—	—		
MAX3286/MAX3296	VCC	VCC	Not allowed; fault occurs	—
MAX3286/MAX3296	GND	GND	Not allowed; fault occurs	—

3.0V to 5.5V, 1.25Gbps/2.5Gbps LAN Laser Drivers

MAX3286-MAX3289/MAX3296-MAX3299

$$R_{DEG} = 0.25 / I_{BIAS(MAX)}$$

Q1 = general-purpose PNP, $\beta > 100$, $f_t > 5\text{MHz}$

B1 = ferrite bead (see *Bias Filter* section)

M1 = general-purpose PMOS device (optional)

Common Cathode with Current Feedback

In the common-cathode configuration with current feedback, a servo control loop is formed by an external PNP transistor (Q1), R_{MON}, the controlled-reference voltage block, R_{SET}, R_{MD}, and the power-control amplifier (Figure 10). The voltage at MD is stabilized to 1.7V. The voltage at MON is set by the resistors R_{SET} and R_{MD}. As in the short-wavelength configuration, a 0.1 μF

C_{BIASDRV} connected between BIASDRV and V_{CC} is sufficient to obtain approximately a 1 μs APC loop time constant. This improves power-supply noise rejection.

To select the external components:

- 1) Determine the required laser bias current:

$$I_{BIAS} = I_{TH} + i_{MOD}/2$$

- 2) Select R_{MD} and R_{SET}.

Maxim recommends R_{SET} = 1k Ω , R_{MD} = 5k Ω , which results in V_{CC} - V_{MON} \approx 250mV.

- 3) Select R_{MON} where R_{MON} = 250mV / I_{BIAS}, assuming R_{SET} = 1k Ω and R_{MD} = 5k Ω .

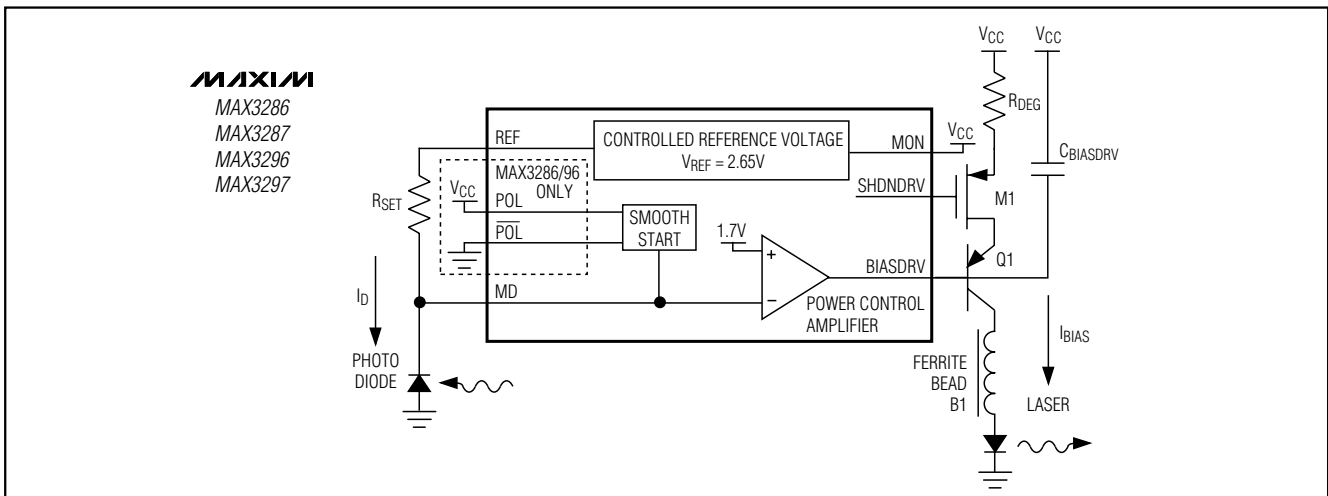

Figure 9. Common-Cathode Laser with Photodiode

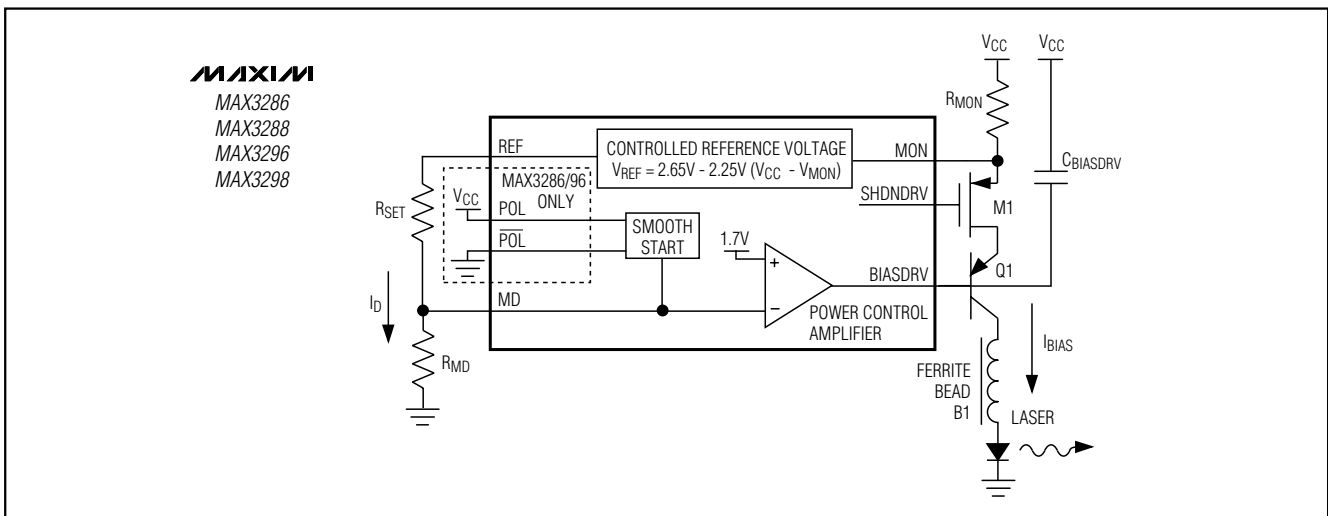

Figure 10. Common Cathode with Current Feedback (PNP Configuration)

3.0V to 5.5V, 1.25Gbps/2.5Gbps LAN Laser Drivers

The relationship between laser bias current and R_{MON} is shown in Figure 11. The remaining discrete components used with the common-cathode without photodiode configuration are as follows:

- Q1 = general-purpose PNP, $\beta > 100$, $f_t > 5\text{MHz}$
- B1 = ferrite bead (see *Bias Filter* section)
- M1 = general-purpose PMOS device (optional)
- $C_{BIASDRV} = 0.1\mu\text{F}$ (typ)

Common Anode with Photodiode

In the common-anode configuration with photodiode, a servo control loop is formed by an external NPN transistor (Q1), the laser diode, the monitor diode, R_{SET} , and the power-control amplifier. The voltage at MD is stabilized to 1.7V. The monitor photodiode current is set by $I_D = V_{MD} / R_{SET}$ (Figure 12). Determine the desired monitor current (I_D), then select $R_{SET} = 1.7\text{V} / I_D$.

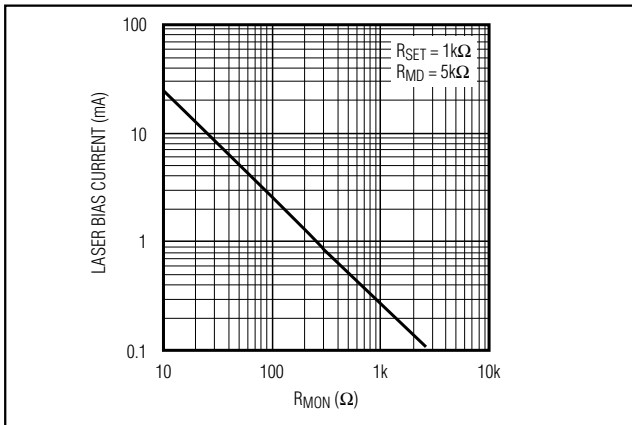

Figure 11. Common Cathode Without Photodiode Laser

$C_{BIASDRV}$ and a degeneration resistor (R_{DEG}) must be connected to the bias transistor (in this case NPN) to obtain the desired APC loop time constant. This improves power-supply (and ground) noise rejection. A capacitance of $0.1\mu\text{F}$ is sufficient to obtain time constants of up to $5\mu\text{s}$ in most cases. The voltage across R_{DEG} should not be larger than 250mV at maximum bias current.

The discrete components used with the common-anode with photodiode configuration are summarized as follows:

- $R_{SET} = 1.7 / I_D$
- $C_{BIASDRV} = 0.1\mu\text{F}$ (typ)
- $R_{DEG} = 0.25 / I_{BIAS(MAX)}$
- Q1 = general-purpose NPN, $\beta > 100$, $f_t > 5\text{MHz}$
- B1 = ferrite bead (see *Bias Filter* section)
- M1 = general-purpose PMOS (optional)

Programming POR Delay

A capacitor may be added to $PORDLY$ to increase the delay for which POR will be asserted low (meaning that V_{CC} is within the operational range) when powering up the part.

The delay will be approximately:

$$t = \frac{C_{PORDLY}}{(1.4)10^{-6}} \text{ [s]}$$

See *Typical Operating Characteristics*.

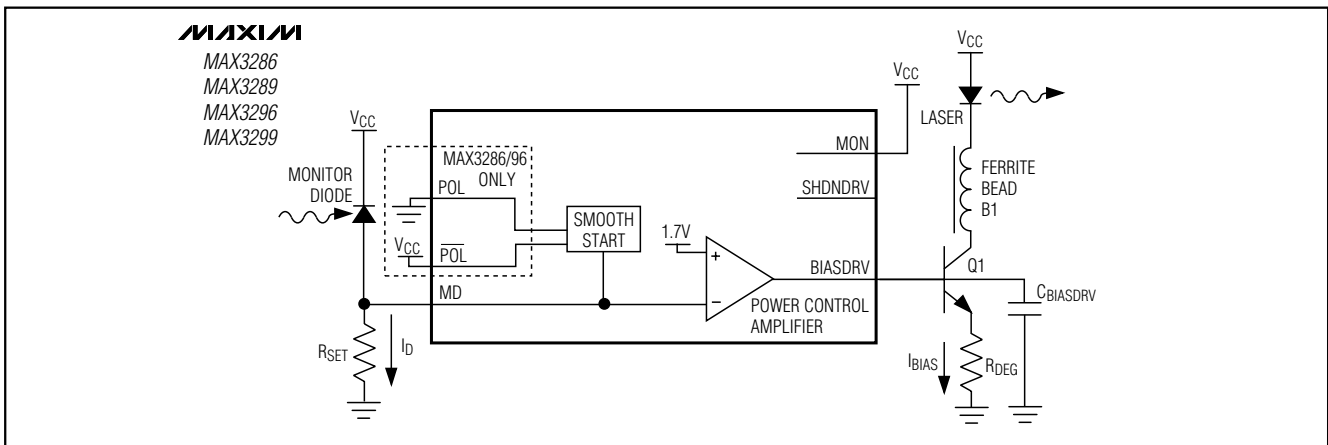

Figure 12. Common Anode With Photodiode

3.0V to 5.5V, 1.25Gbps/2.5Gbps LAN Laser Drivers

Designing the Bias Filter and Output Pull-Up Beads

To reduce deterministic jitter, add a ferrite-bead inductor between the collector of the biasing transistor and either the anode or cathode of the laser, depending on type (see *Typical Operating Characteristics*). Use a ferrite-bead inductor with an impedance $>100\Omega$ between $f = 10\text{MHz}$ and $f = 2\text{GHz}$, and a DC resistance $< 3\Omega$. Maxim recommends the Murata BLM11HA102SG. These inductors are also desirable for tying the OUT+ and OUT- pins to VCC.

Designing the Laser-Compensation Filter Network

Laser package inductance causes the laser impedance to increase at high frequencies, leading to ringing, overshoot, and degradation of the output eye pattern. A laser-compensation filter network can be used to reduce the output load seen by the laser driver at high frequencies, thereby reducing output ringing and overshoot.

The compensation components (R_{COMP} and C_{COMP}) are most easily determined by experimentation. Begin with R_{COMP} = 25 Ω and C_{COMP} = 2pF. Increase C_{COMP} until the desired transmitter eye is obtained (Figure 13).

Quick Shutdown

To reduce laser shutdown time, a FET device can be attached to SHDNDRV as shown in Figure 10. This will provide a typical laser power shutdown time of less than 10 μs .

Applications Information

Laser Safety and IEC 825

The International Electrotechnical Commission (IEC) determines standards for hazardous light emissions from fiber optic transmitters. IEC 825 defines the maximum light output for various hazard levels. The MAX3286/MAX3296 series provide features that facilitate compliance with IEC 825.

A common safety requirement is single-point fault tolerance, whereby one unplanned short, open, or resistive connection does not cause excess light output. When these laser drivers are used as shown in the *Typical Operating Circuits*, the circuits respond to faults as shown in Table 5.

Using these laser drivers alone does not ensure that a transmitter design is compliant with IEC 825. The entire transmitter circuit and component selections must be considered. Customers must determine the level of fault tolerance required by their applications, recognizing that Maxim products are not designed or authorized for use as components in systems intended for surgical implant

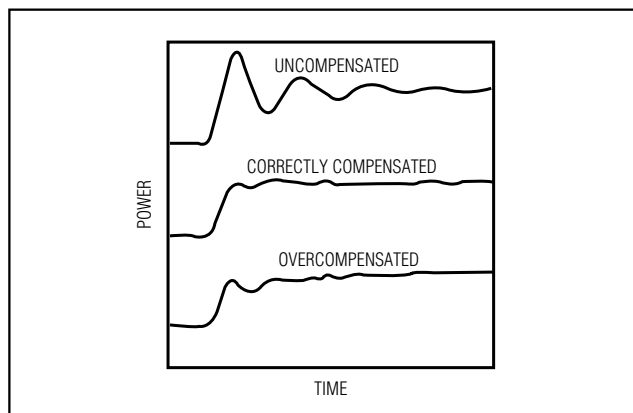

Figure 13. Laser Compensation

into the body, for applications intended to support or sustain life, or for any other application where the failure of a Maxim product could create a situation where personal injury or death may occur.

Layout Considerations

The MAX3286/MAX3296 series are high-frequency products. Their performance largely depends upon the circuit board layout.

Use a multilayer circuit board with a dedicated ground plane. Use short laser package leads placed close to the modulator outputs. Power supplies must be capacitively bypassed to the ground plane with surface-mount capacitors placed near the power-supply pins.

The dominant pole of the APC circuit is normally located at BIASDRV. To prevent a second pole in the APC (that can lead to oscillations), ensure that parasitic capacitance at MD is minimized.

Common Questions

Laser output is ringing or contains overshoot. This is often caused by inductive laser packaging. Try reducing the length of the laser leads. Modify the compensation components to reduce the driver's output edge speed (see *Design Procedure*). Extreme ringing can be caused by low voltage at the OUT \pm pins. This may indicate that pull-up beads or a lower modulation current are needed.

Low-frequency oscillation on the laser output. This is more prevalent at low temperatures. The APC may be oscillating. Try increasing the value of C_{BIASDRV} or increasing the value of R_{DEG}. Ensure that the parasitic capacitance at the MD node is kept very small ($<10\text{pF}$).

The APC is not needed. Connect FLTDLY to ground to disable fault detection. Connect MD to REF and MON to VCC. BIASDRV and SHDNDRV can be left open.

3.0V to 5.5V, 1.25Gbps/2.5Gbps LAN Laser Drivers

Table 5. Circuit Response to Various Single-Point Faults

PIN NAME	CIRCUIT RESPONSE TO OVERVOLTAGE OR SHORT TO V _{CC}	CIRCUIT RESPONSE TO UNDERVOLTAGE OR SHORT TO GROUND
MAX3286/MAX3296 ONLY		
FAULT	Does not affect laser power.	Does not affect laser power.
FAULT	Does not affect laser power.	Does not affect laser power.
POR	Does not affect laser power.	Does not affect laser power.
PORDLY	Does not affect laser power.	Fault state* occurs.
EN	Normal condition for circuit operation.	Fault state* occurs.
$\overline{\text{EN}}$	Fault state* occurs.	Normal condition for circuit operation.
LV	Does not affect laser power.	Fault state* occurs if V _{CC} is less than +4.5V.
POL	If $\overline{\text{POL}}$ is a TTL HIGH, a fault state* occurs; otherwise, the circuit is in normal operation.	If $\overline{\text{POL}}$ is a TTL LOW, a fault state* occurs; otherwise, the circuit is in normal operation.
$\overline{\text{POL}}$	If POL is a TTL HIGH, a fault state* occurs; otherwise, the circuit is in normal operation.	If POL is a TTL LOW, a fault state* occurs; otherwise, the circuit is in normal operation.
MON (Also MAX3288/98)	In common-cathode without photodiode configuration, a fault state* occurs; otherwise, does not affect laser power.	A fault state* occurs.
SHDNDRV (Also MAX3287/97/ 89/99)	Does not affect laser power. If optional FET is used, the laser output is shut off.	Does not affect laser power.
ALL DEVICES		
FLTDLY	Any fault that occurs cannot be reset. Does not affect laser power.	Does not affect laser power.
IN+, IN-	Does not affect laser power.	Does not affect laser power.
REF	Fault state* occurs.	In common cathode configurations, a fault state* occurs; otherwise, does not affect laser power.
MD	Fault state* occurs.	A fault state* occurs.
BIASDRV	In common cathode configurations, the laser bias current is shut off. In common anode, high laser power triggers a fault state*. Shutdown occurs if a shutdown FET (M1) is used. If shutdown FET is not used, other means must be used to prevent high laser power.	In common anode configurations, the laser bias current is shut off. In common cathode, high laser power triggers a fault state*. Shutdown occurs if a shutdown FET (M1) is used (Figures 9,10).
OUT+, OUT-	Does not affect laser power.	Does not affect laser power.
MODSET	Does not affect laser power.	Fault state* occurs.
TC	Does not affect laser power.	Fault state* occurs.

* A fault state will assert the FAULT pins, disable the modulator outputs, disable the bias output, and assert the SHDNDRV pin.

3.0V to 5.5V, 1.25Gbps/2.5Gbps LAN Laser Drivers

The modulator is not needed. Leave TC and MODSET open. Connect IN+ to VCC. IN- to REF, and leave OUT+ and OUT- open.

Wirebonding Die

The MAX3286/MAX3296 series use bondpads with gold metalization. Make connections to the die with gold wire only, using ball-bonding techniques. Wedge bonding is not recommended. Bondpad size is 4mil square. Die thickness is typically 15mils (0.38mm).

Interface Models

Figures 14–18 show typical input/output models for the MAX3286/MAX3296 series of laser drivers. If dice are used, replace the package parasitic elements with bondwire parasitic elements.

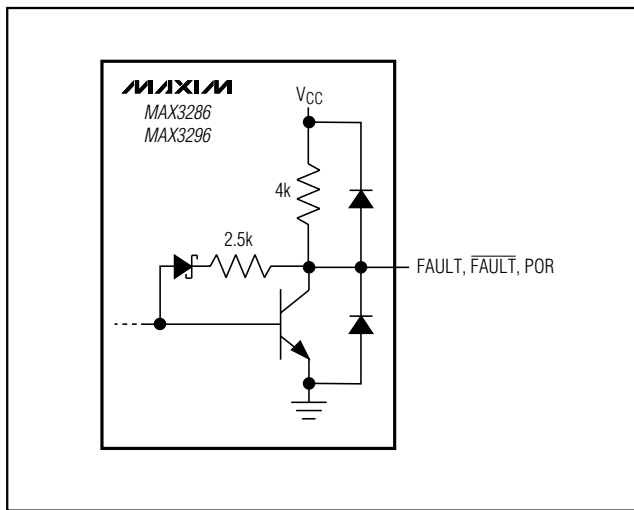

Figure 14. Logic Outputs

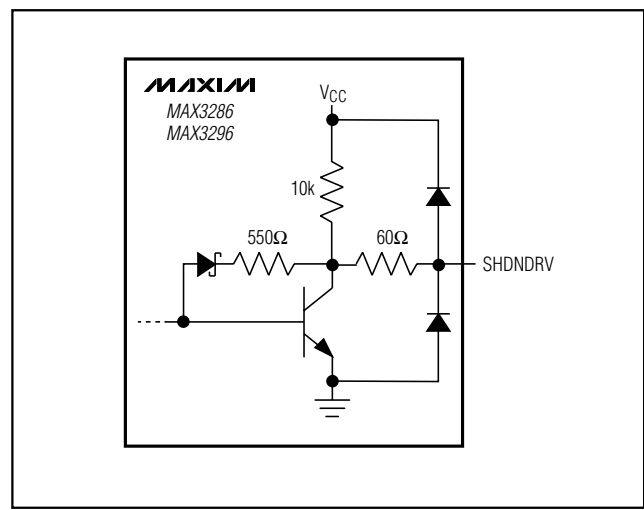

Figure 15. SHDNDRV Output

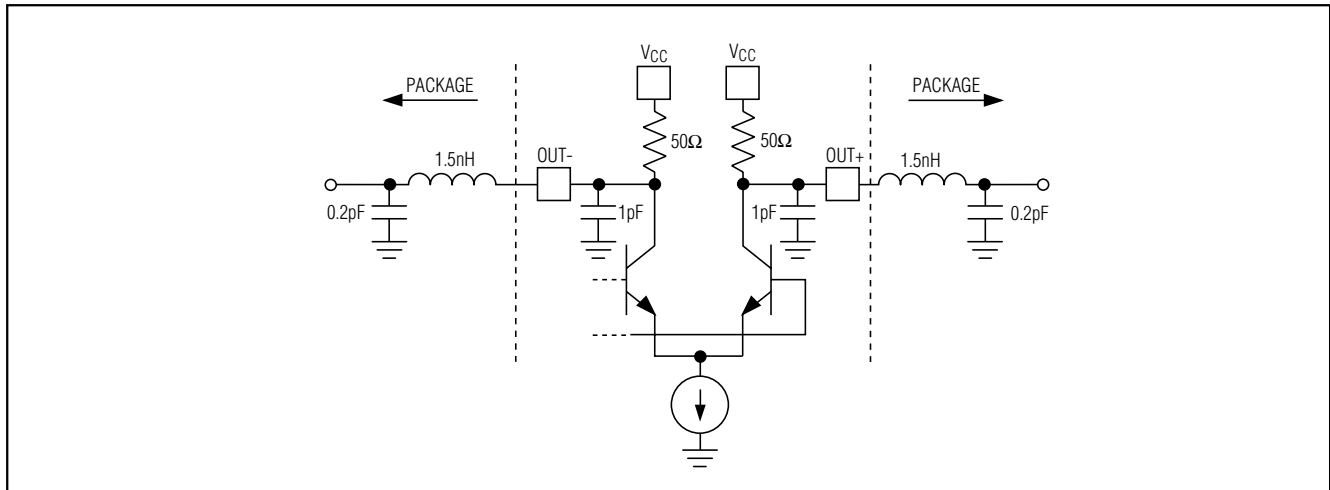

Figure 16. Modulator Outputs

MAX3286-MAX3289/MAX3296-MAX3299

3.0V to 5.5V, 1.25Gbps/2.5Gbps LAN Laser Drivers

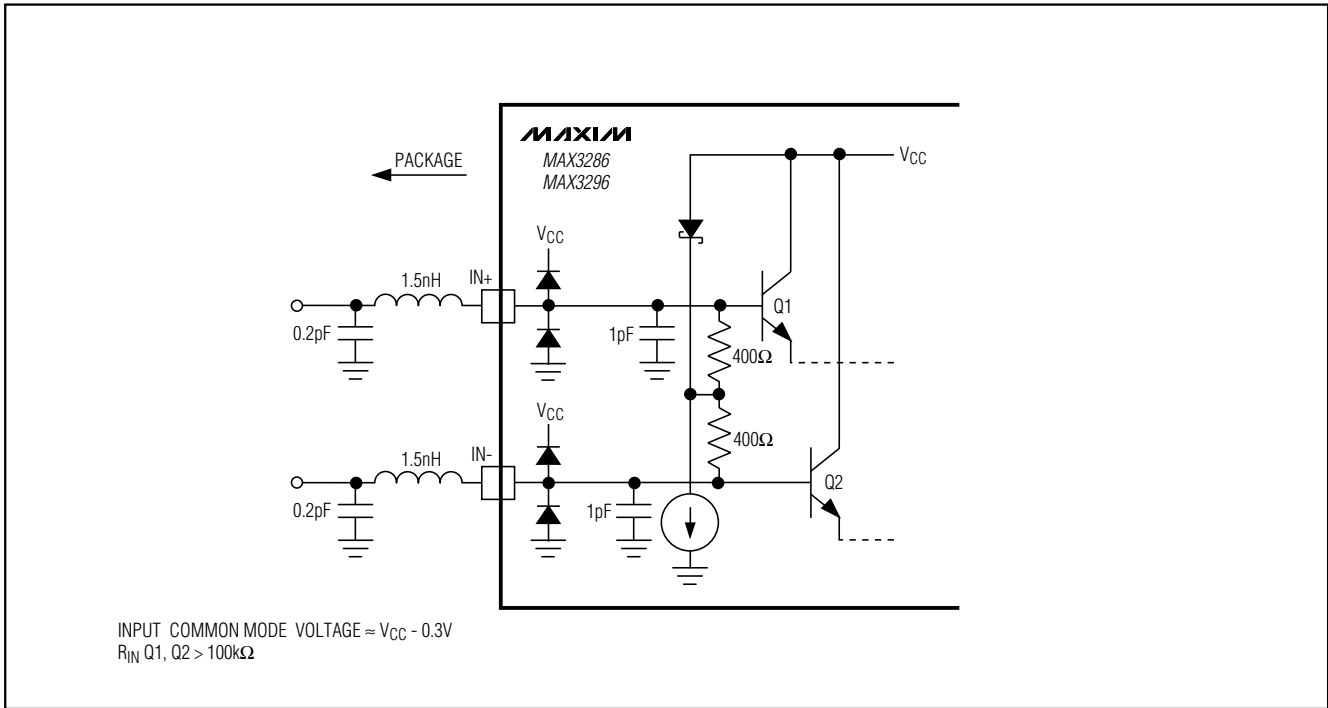

Figure 17. Data Inputs

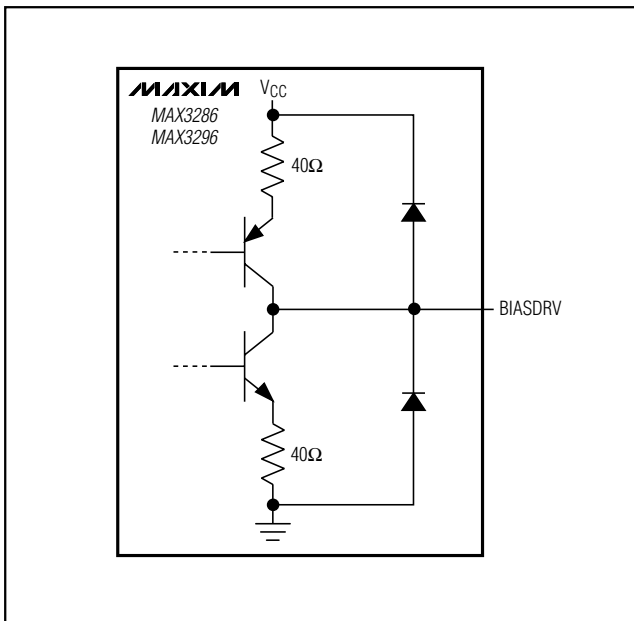

Figure 18. BIASDRV Output

3.0V to 5.5V, 1.25Gbps/2.5Gbps LAN Laser Drivers

Selector Guide

DATA RATE/DEVICE		LASER CONFIGURATION			PACKAGE
1.25Gbps	2.5Gbps	COMMON ANODE WITH PHOTODIODE	COMMON CATHODE WITH PHOTODIODE	COMMON CATHODE WITHOUT PHOTODIODE	
		Longwave	Shortwave or VCSEL	VCSEL	
MAX3286	MAX3296	✓	✓	✓	32 TQFP/Dice
MAX3287	MAX3297		✓		16 TSSOP-EP
MAX3288	MAX3298			✓	16 TSSOP-EP
MAX3289	MAX3299	✓			16 TSSOP-EP

Pin Configurations (continued)

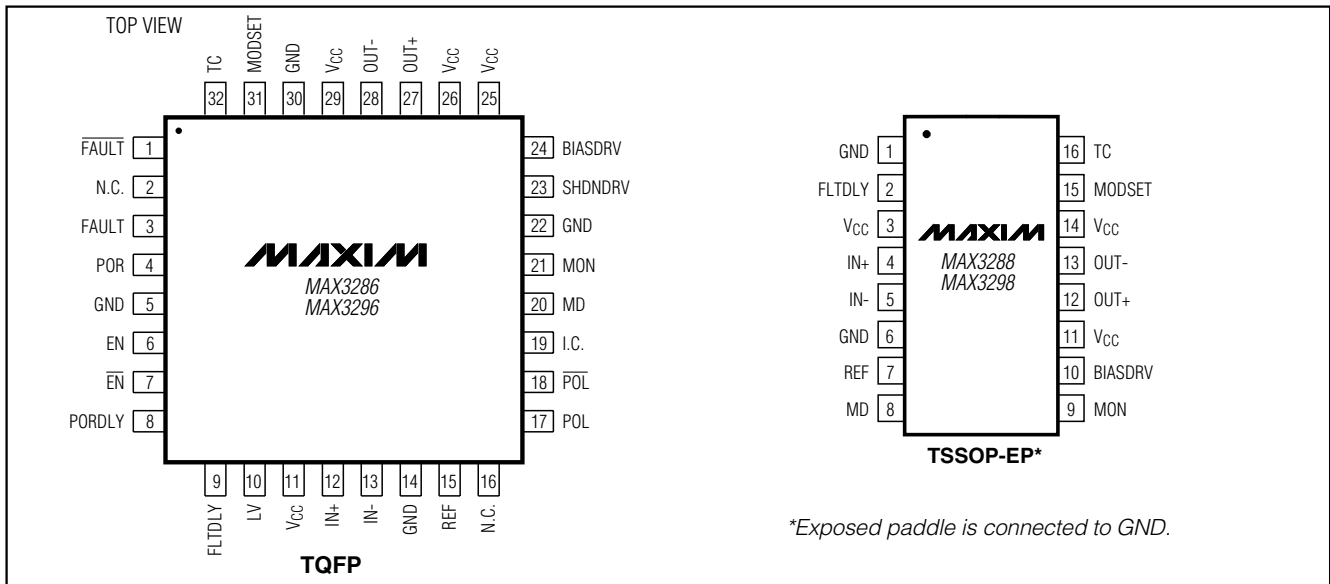

Ordering Information (continued)

PART	TEMP. RANGE	PIN-PACKAGE
MAX3287CUE	0°C to +70°C	16 TSSOP-EP**
MAX3288CUE	0°C to +70°C	16 TSSOP-EP**
MAX3289CUE	0°C to +70°C	16 TSSOP-EP**
MAX3296CHJ	0°C to +70°C	32 TQFP (5mm x 5mm)
MAX3296C/D	0°C to +70°C	Dice*
MAX3297CUE	0°C to +70°C	16 TSSOP-EP**
MAX3298CUE	0°C to +70°C	16 TSSOP-EP**
MAX3299CUE	0°C to +70°C	16 TSSOP-EP**

*Dice are designed to operate from $T_J = 0^\circ\text{C}$ to $+110^\circ\text{C}$, but are tested and guaranteed only at $T_A = +25^\circ\text{C}$.

**Exposed paddle

3.0V to 5.5V, 1.25Gbps/2.5Gbps LAN Laser Drivers

Typical Application Circuits

MAX3286-MAX3289/MAX3296-MAX3299

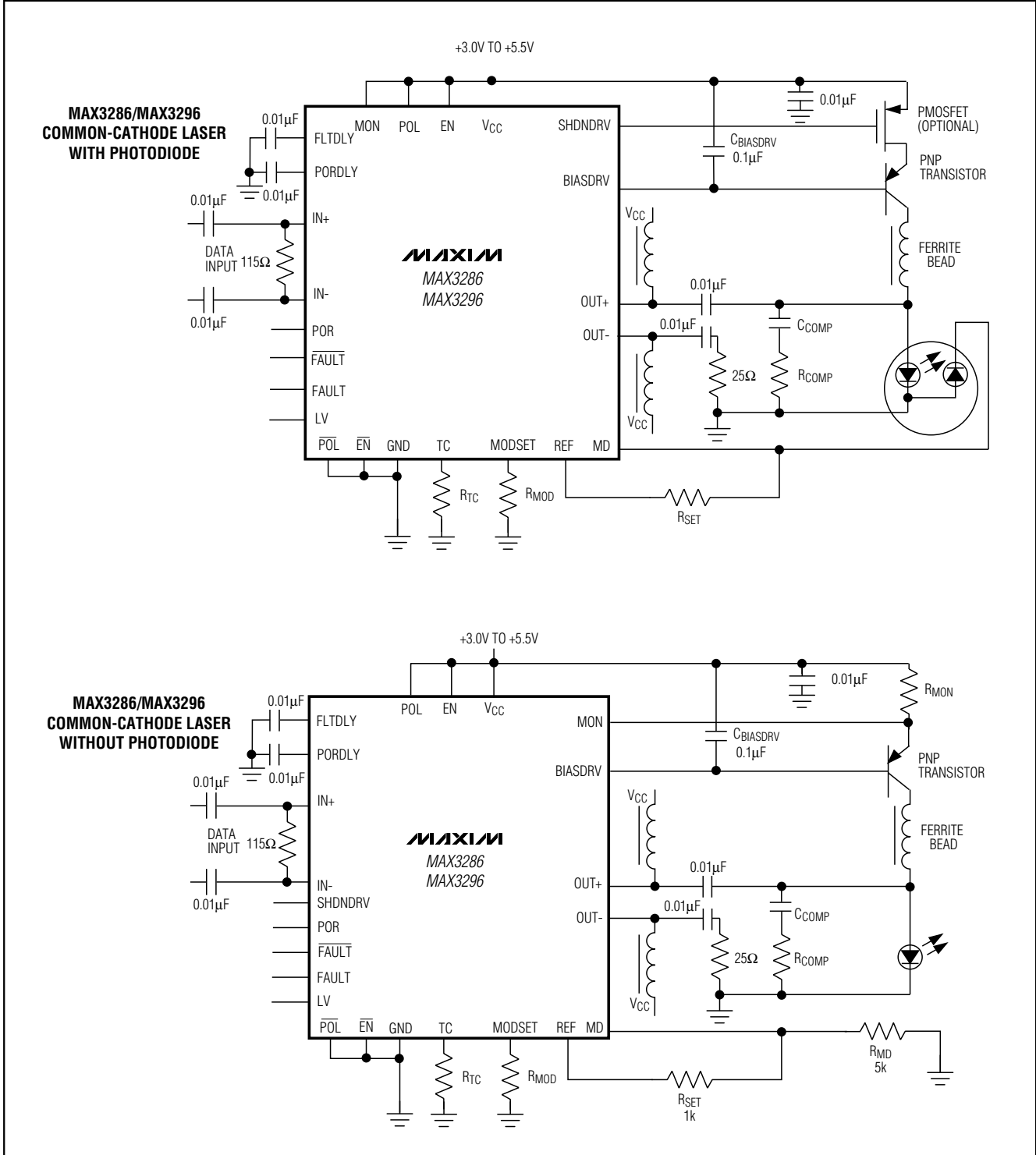

3.0V to 5.5V, 1.25Gbps/2.5Gbps LAN Laser Drivers

Typical Application Circuits (continued)

MAX3286-MAX3289/MAX3296-MAX3299

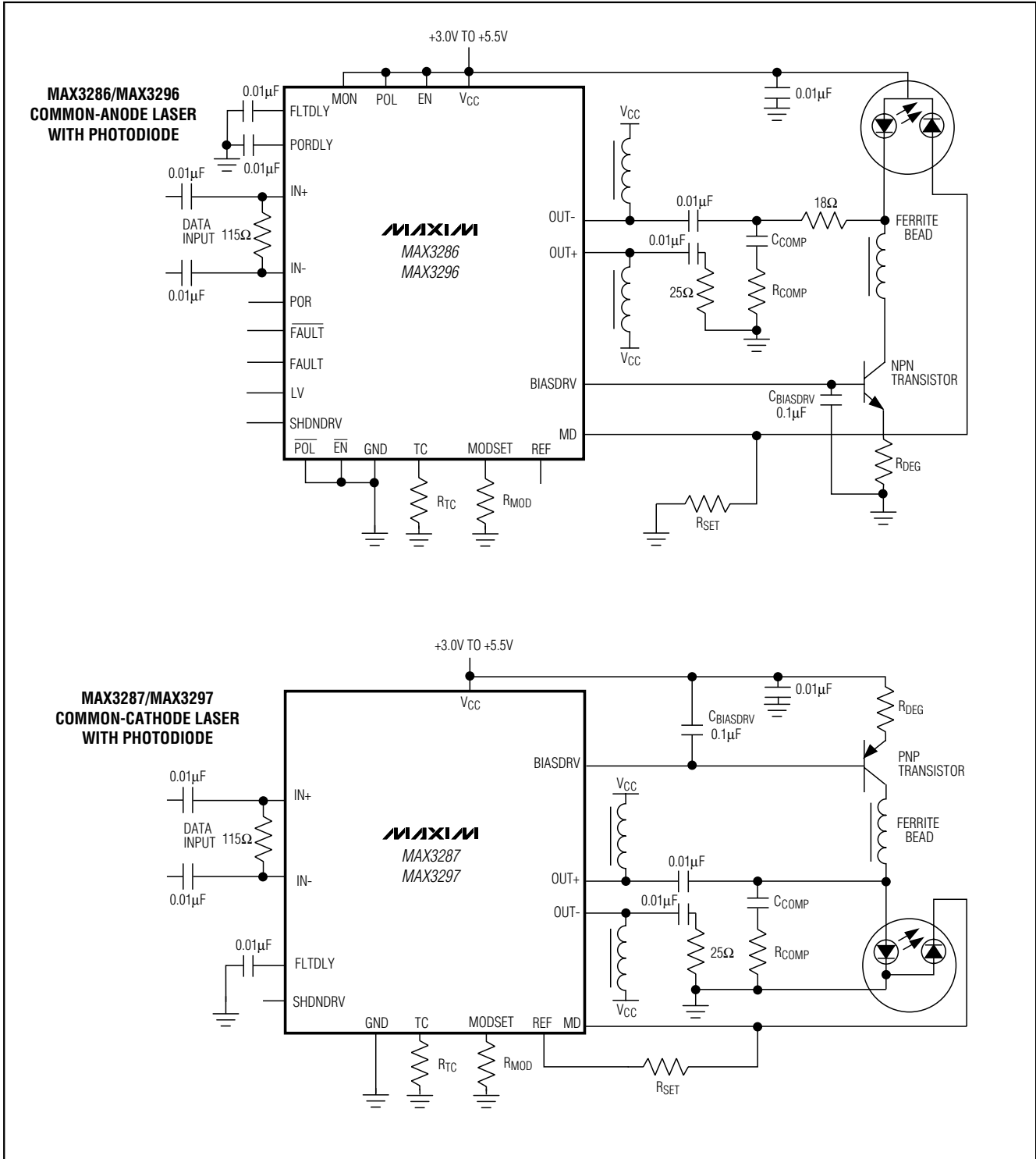

3.0V to 5.5V, 1.25Gbps/2.5Gbps LAN Laser Drivers

Typical Application Circuits (continued)

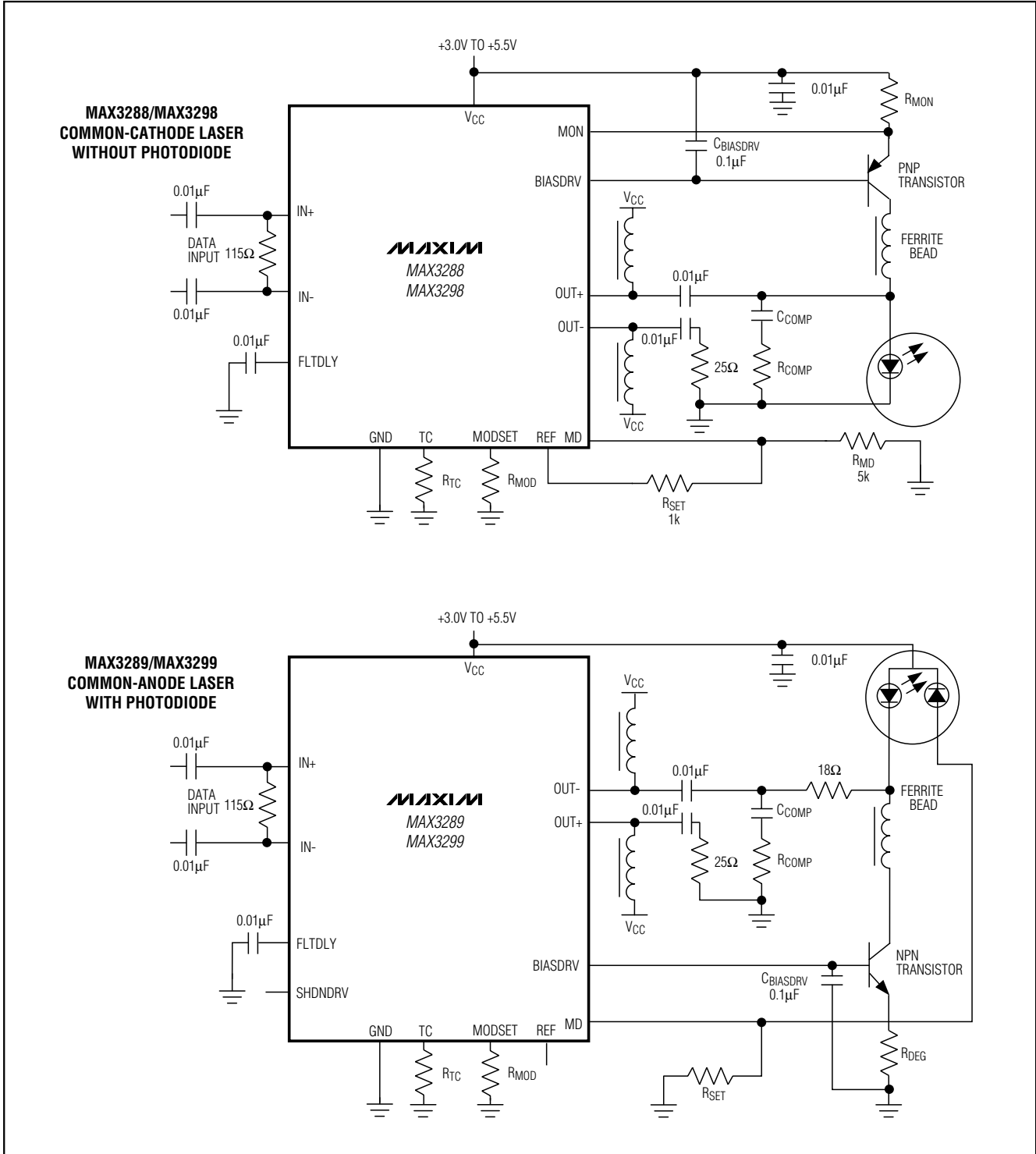

3.0V to 5.5V, 1.25Gbps/2.5Gbps LAN Laser Drivers

Chip Topographies

MAX3286-MAX3289/MAX3296-MAX3299

MAX3286

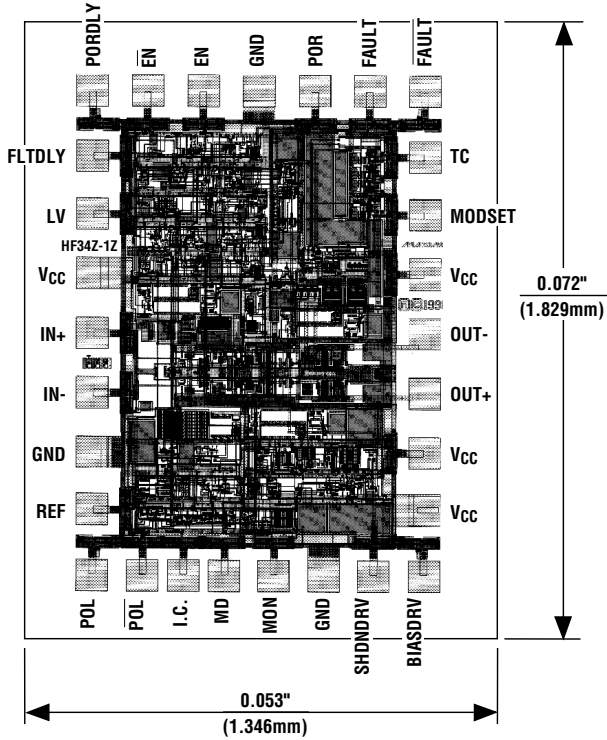

TRANSISTOR COUNT: 1154
SUBSTRATE CONNECTED TO GND

MAX3296

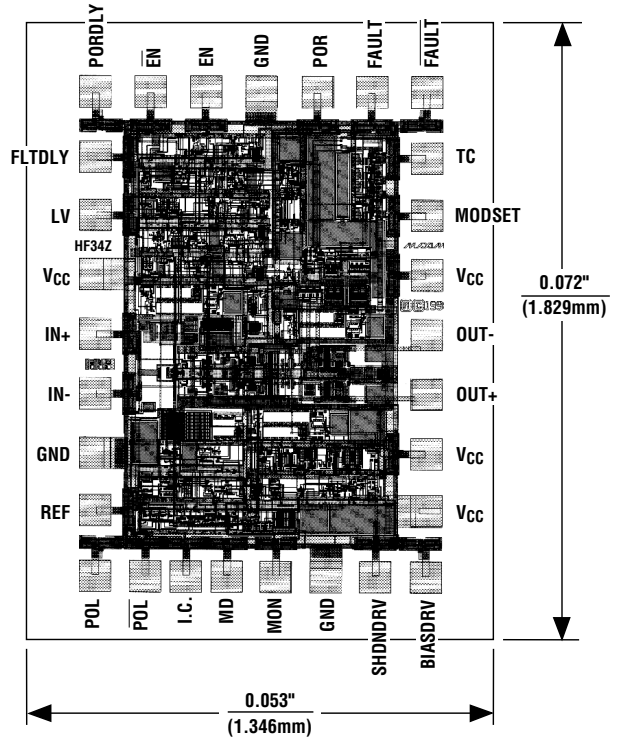

TRANSISTOR COUNT: 1154
SUBSTRATE CONNECTED TO GND

3.0V to 5.5V, 1.25Gbps/2.5Gbps LAN Laser Drivers

Package Information

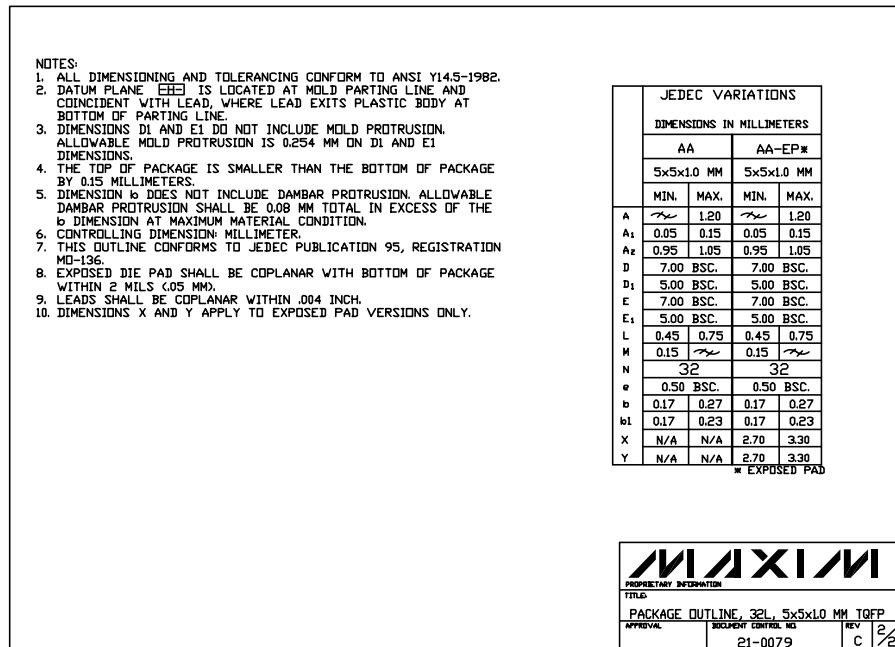
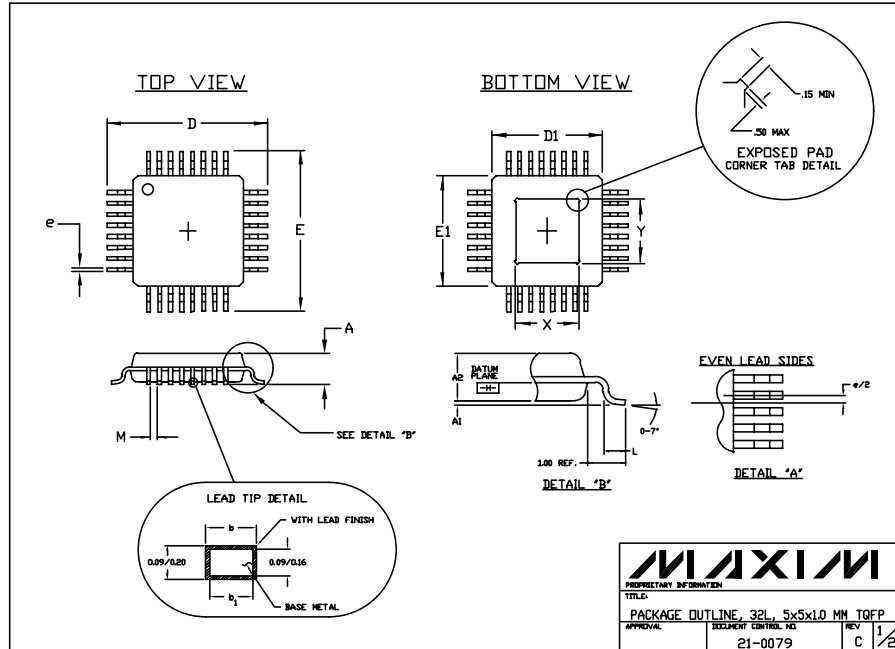

3.0V to 5.5V, 1.25Gbps/2.5Gbps LAN Laser Drivers

Package Information (continued)

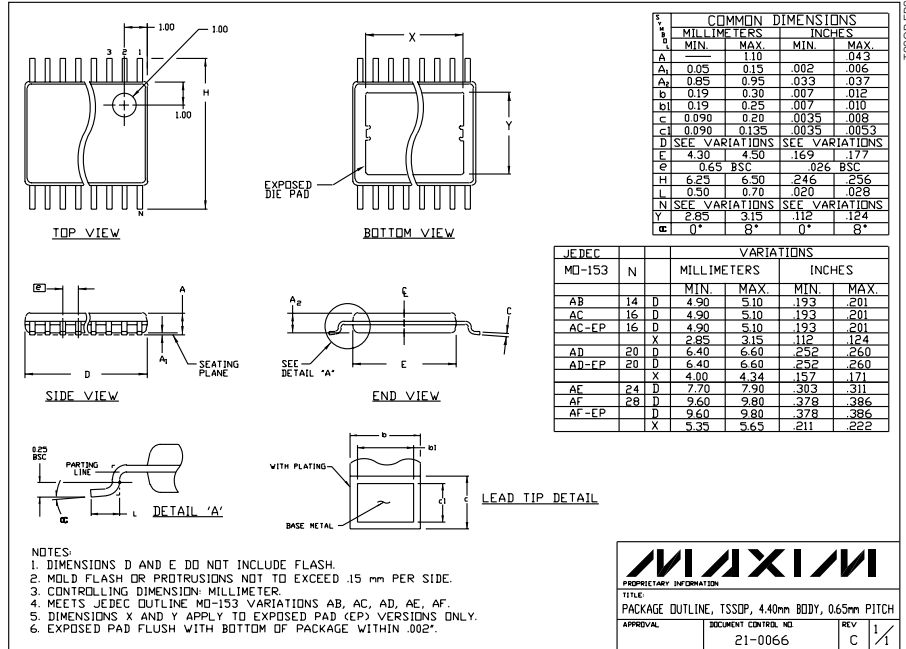

MAX3286-MAX3289/MAX3296-MAX3299

3.0V to 5.5V, 1.25Gbps/2.5Gbps LAN Laser Drivers

MAX3286-MAX3289/MAX3296-MAX3299

NOTES

3.0V to 5.5V, 1.25Gbps/2.5Gbps LAN Laser Drivers

NOTES

MAX3286-MAX3289/MAX3296-MAX3299

3.0V to 5.5V, 1.25Gbps/2.5Gbps LAN Laser Drivers

NOTES

Maxim makes no warranty, representation or guarantee regarding the suitability of its products for any particular purpose, nor does Maxim assume any liability arising out of the application or use of any product or circuit and specifically disclaims any and all liability, including without limitation consequential or incidental damages. "Typical" parameters can and do vary in different applications. All operating parameters, including "typicals" must be validated for each customer application by customer's technical experts. Maxim products are not designed, intended or authorized for use as components in systems intended for surgical implant into the body, or other applications intended to support or sustain life, or for any other application in which the failure of the Maxim product could create a situation where personal injury or death may occur.

28 _____ **Maxim Integrated Products, 120 San Gabriel Drive, Sunnyvale, CA 94086 408-737-7600**