

EVALUATION KIT
AVAILABLE**MAXIM****+3.3V, 2.5Gbps SDH/SONET Laser Driver
with Current Monitors and APC****General Description**

The MAX3869 is a complete, single +3.3V laser driver for SDH/SONET applications up to 2.5Gbps. The device accepts differential PECL data and clock inputs and provides bias and modulation currents for driving a laser. A synchronizing input latch can be used (if a clock signal is available) to reduce jitter.

An automatic power control (APC) feedback loop is incorporated to maintain a constant average optical power over temperature and lifetime. The wide modulation current range of 5mA to 60mA and bias current of 1mA to 100mA are easy to program, making this product ideal for use in various SDH/SONET applications.

The MAX3869 also provides enable control, two current monitors that are directly proportional to the laser bias and modulation currents, and a failure-monitor output to indicate when the APC loop is unable to maintain the average optical power. The MAX3869 is available in a small 32-pin TQFP package as well as dice.

Applications

SONET/SDH Transmission Systems
Add/Drop Multiplexers
Digital Cross-Connects
Section Regenerators
2.5Gbps Optical Transmitters

Features

- ◆ Single +3.3V or +5V Power Supply
- ◆ 64mA Supply Current at +3.3V
- ◆ Programmable Bias Current from 1mA to 100mA
- ◆ Programmable Modulation Current from 5mA to 60mA
- ◆ Bias Current and Modulation Current Monitors
- ◆ 87ps Rise/Fall Time
- ◆ Automatic Average Power Control with Failure Monitor
- ◆ Complies with ANSI, ITU, and Bellcore SDH/SONET Specifications
- ◆ Enable Control

Ordering Information

PART	TEMP. RANGE	PIN-PACKAGE
MAX3869EHJ	-40°C to +85°C	32 TQFP-EP*
MAX3869E/D	-40°C to +85°C	Dice**

*EP = Exposed Paddle.

**Dice are designed to operate over this range, but are tested and guaranteed at $T_A = +25^\circ\text{C}$ only. Contact factory for availability.

Pin Configuration appears at end of data sheet.

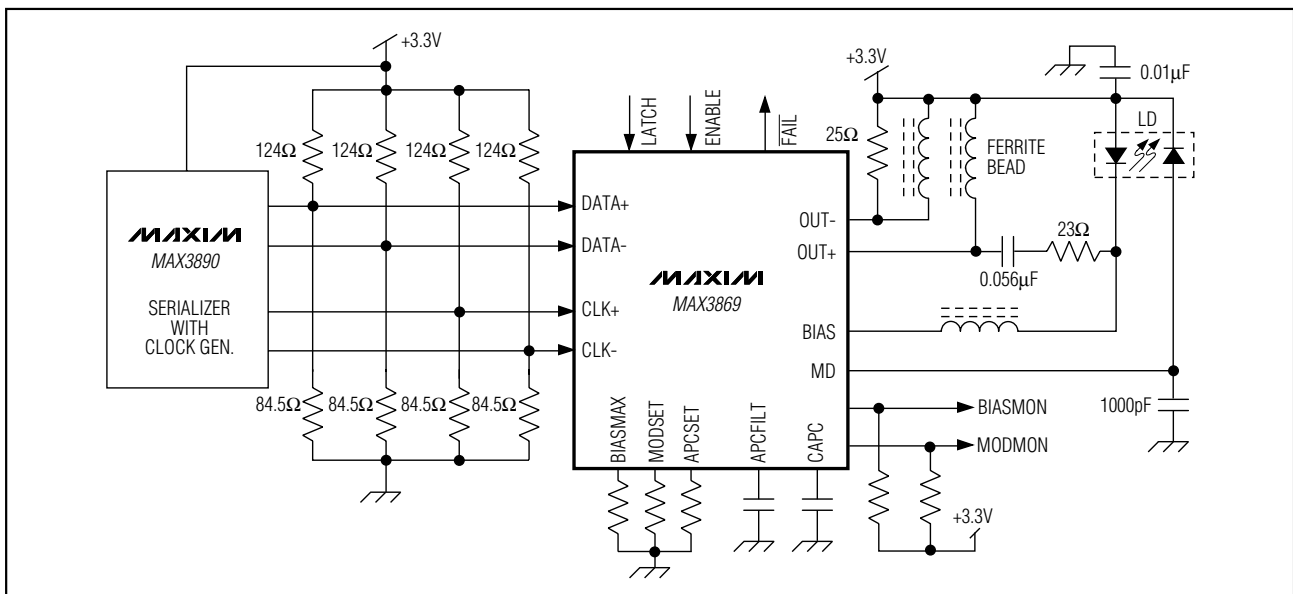
Typical Application Circuit**MAXIM**

Maxim Integrated Products 1

For free samples & the latest literature: <http://www.maxim-ic.com>, or phone 1-800-998-8800.
For small orders, phone 1-800-835-8769.

MAX3869

+3.3V, 2.5Gbps SDH/SONET Laser Driver with Current Monitors and APC

ABSOLUTE MAXIMUM RATINGS

Supply Voltage, V_{CC}	-0.5V to +7.0V	Voltage at OUT+, OUT-.....	+1.5V to ($V_{CC} + 1.5V$)
Current into BIAS	-20mA to +150mA	Voltage at BIAS	+1.0V to ($V_{CC} + 0.5V$)
Current into OUT+, OUT-.....	-20mA to +100mA	Continuous Power Dissipation ($T_A = +85^\circ\text{C}$)	
Current into MD.....	-5mA to +5mA	32-Pin TQFP-EP (derate 22.2mW/ $^\circ\text{C}$ above $+85^\circ\text{C}$) ..	1444mW
Voltage at DATA+, DATA-, CLK+, CLK-, ENABLE, LATCH, FAIL, BIASMON, MODMON	-0.5V to ($V_{CC} + 0.5V$)	Storage Temperature Range	-65 $^\circ\text{C}$ to +165 $^\circ\text{C}$
Voltage at APCFILT, CAPC, MODSET, BIASMAX, APCSET	-0.5V to +3.0V	Operating Junction Temperature Range	-55 $^\circ\text{C}$ to +150 $^\circ\text{C}$
		Processing Temperature (die)	+400 $^\circ\text{C}$
		Lead Temperature (soldering, 10s)	+300 $^\circ\text{C}$

Stresses beyond those listed under "Absolute Maximum Ratings" may cause permanent damage to the device. These are stress ratings only, and functional operation of the device at these or any other conditions beyond those indicated in the operational sections of the specifications is not implied. Exposure to absolute maximum rating conditions for extended periods may affect device reliability.

DC ELECTRICAL CHARACTERISTICS

($V_{CC} = +3.14V$ to $+5.5V$, $T_A = -40^\circ\text{C}$ to $+85^\circ\text{C}$. Typical values are at $V_{CC} = +3.3V$, $I_{MOD} = 30\text{mA}$, $I_{BIAS} = 60\text{mA}$, $T_A = +25^\circ\text{C}$, unless otherwise noted.) (Note 1)

PARAMETER	SYMBOL	CONDITIONS		MIN	TYP	MAX	UNITS
Supply Current	I_{CC}	(Note 2)			64	112	mA
Bias Current Range	I_{BIAS}	(Note 3)		1		100	mA
Bias Off-Current	$I_{BIAS-OFF}$	ENABLE = low (Note 4)				100	μA
Bias-Current Stability		APC open loop	$I_{BIAS} = 100\text{mA}$	230			ppm/ $^\circ\text{C}$
			$I_{BIAS} = 1\text{mA}$	900			
Bias-Current Absolute Accuracy	(Note 5)	APC open loop		-15		15	%
Differential Input Voltage	V_{ID}	Figure 1		200		1600	mVp-p
Common-Mode Input Voltage	V_{ICM}	PECL compatible		$V_{CC} - 1.49$	$V_{CC} - 1.32$	$V_{CC} - V_{ID}/4$	V
Clock and Data Input Current	I_{IN}			-1		10	μA
TTL Input High Voltage		ENABLE, LATCH		2.0			V
TTL Input Low Voltage		ENABLE, LATCH				0.8	V
TTL Output High Voltage $\overline{\text{FAIL}}$		Sourcing 50 μA		2.4	$V_{CC} - 0.3$	V_{CC}	V
TTL Output Low Voltage $\overline{\text{FAIL}}$		Sinking 100 μA		0.1		0.44	V
Monitor-Diode Reverse Bias Voltage				1.5			V
Monitor-Diode DC Current Range	I_{MD}			18		1000	μA
Monitor-Diode Bias Setpoint Stability		(Note 6)	$I_{MD} = 1\text{mA}$	-480	50	480	ppm/ $^\circ\text{C}$
			$I_{MD} = 18\mu\text{A}$	90			
Monitor-Diode Bias Absolute Accuracy		(Note 5)		-15		15	%
BIASMON to I_{BIAS} Gain	A_{BIAS}	$I_{BIAS}/I_{BIASMON}$			37		A/A
MODMON to I_{MOD} Gain	A_{MOD}	I_{MOD}/I_{MODMON}			29		A/A

+3.3V, 2.5Gbps SDH/SONET Laser Driver with Current Monitors and APC

MAX3869

AC ELECTRICAL CHARACTERISTICS

(VCC = +3.14V to +5.5V, load as shown in Figure 2, TA = -40°C to +85°C. Typical values are at VCC = +3.3V, I_{MOD} = 30mA, TA = +25°C.) (Note 7)

PARAMETER	SYMBOL	CONDITIONS	MIN	TYP	MAX	UNITS
Input Latch Setup Time	t _{SU}	LATCH = high, Figure 3	100			ps
Input Latch Hold Time	t _H	LATCH = high, Figure 3	100			ps
Modulation-Current Range	I _{MOD}		5		60	mA
Modulation-Off Current	I _{MOD-OFF}	ENABLE = low (Note 4)			200	μA
Modulation-Current Stability		I _{MOD} = 60mA	-480	-8	480	ppm/°C
		I _{MOD} = 5mA		300		
Modulation-Current Absolute Accuracy		(Note 5)	-15		15	%
Output Rise Time	t _R	20% to 80% (Note 8)	MAX3869EHJ	78		ps
			MAX3869E/D	69		
Output Fall Time	t _F	20% to 80% (Note 8)	MAX3869EHJ	87	(Note 10)	ps
			MAX3869E/D	79		
Output Aberrations		(Note 8)		±15		%
Enable/Start-Up Delay				250		ns
Maximum Consecutive Identical Digits			80			bits
Pulse-Width Distortion	PWD	(Notes 8, 9)		14	50	ps
Jitter Generation		Jitter BW = 12kHz to 20MHz, 0-1 pattern		7	20	ps _{p-p}

Note 1: Dice are tested at TA = +25°C only.

Note 2: Tested at R_{MODSET} = 2.49kΩ, R_{BIASMAX} = 1.69kΩ, excluding I_{BIAS} and I_{MOD}.

Note 3: Voltage on BIAS pin is (VCC - 1.6V).

Note 4: Both the bias and modulation currents will be switched off if any of the current set pins are grounded.

Note 5: Accuracy refers to part-to-part variation.

Note 6: Assuming that the laser to monitor-diode transfer function does not change with temperature. Guaranteed by design and characterization.

Note 7: AC characteristics are guaranteed by design and characterization.

Note 8: Measured with 622Mbps 0-1 pattern, LATCH = high.

Note 9: PWD = (wider pulse - narrower pulse) / 2.

Note 10: See *Typical Operating Characteristics* for worst-case distribution.

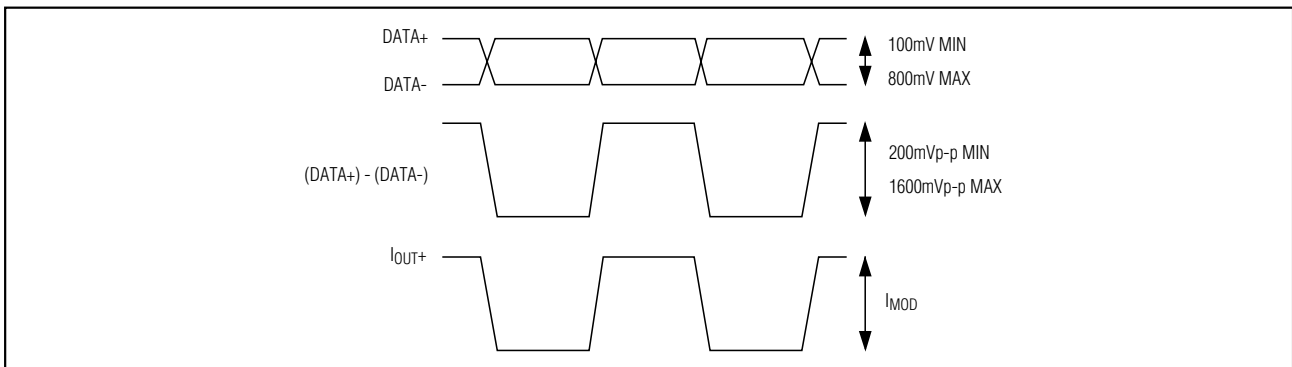

Figure 1. Required Input Signal and Output Polarity

+3.3V, 2.5Gbps SDH/SONET Laser Driver with Current Monitors and APC

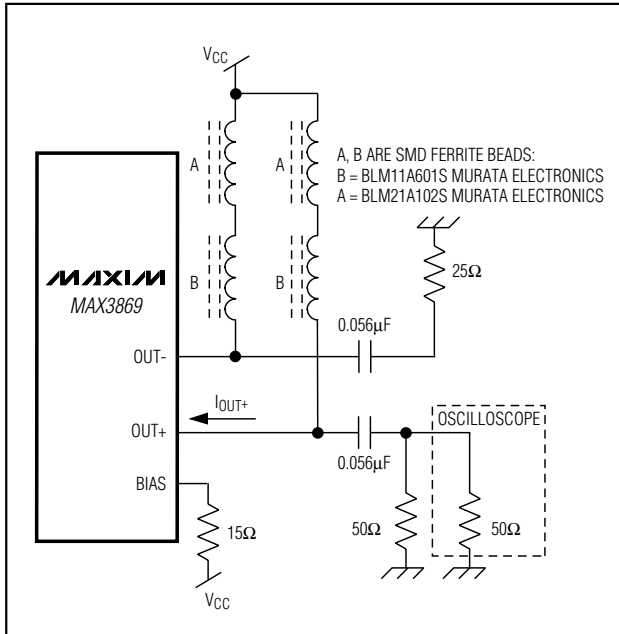

Figure 2. Output Termination for Characterization

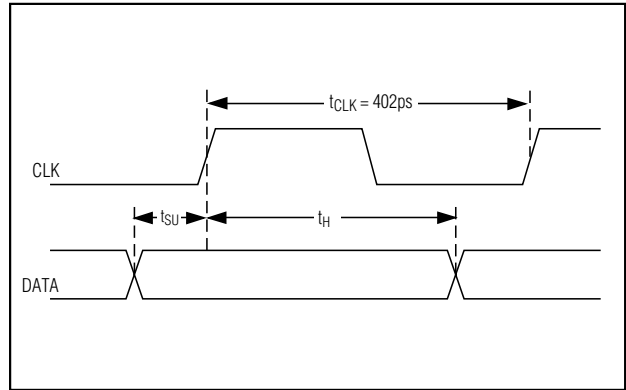
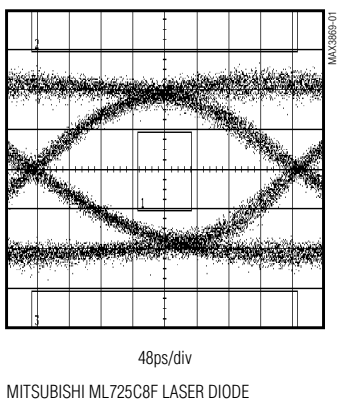

Figure 3. Setup/Hold Time Definition

Typical Operating Characteristics

(VCC = +3.3V, load as shown in Figure 2, TA = +25°C, unless otherwise noted.)

EYE DIAGRAM
(2.488Gbps, 1300nm FP LASER,
1.87GHz FILTER, 32 TQFP-EP)



TYPICAL DISTRIBUTION OF FALL TIME

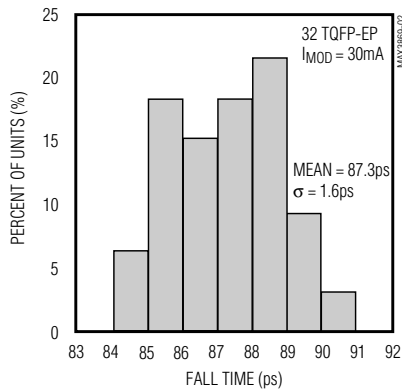

DISTRIBUTION OF FALL TIME
(WORST-CASE CONDITIONS)

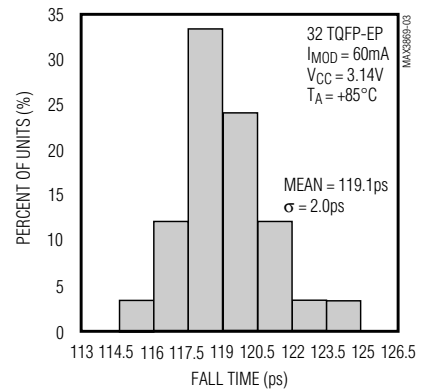

+3.3V, 2.5Gbps SDH/SONET Laser Driver with Current Monitors and APC

MAX3869

Typical Operating Characteristics (continued)

(V_{CC} = +3.3V, load as shown in Figure 2, T_A = +25°C, unless otherwise noted.)

ELECTRICAL EYE DIAGRAM
(I_{MOD} = 30mA, 2¹³-1 +80 CID, 32 TQFP-EP)

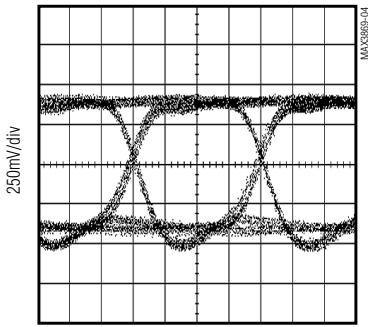

ELECTRICAL EYE DIAGRAM
(I_{MOD} = 60mA, 2¹³-1 +80 CID, 32 TQFP-EP)

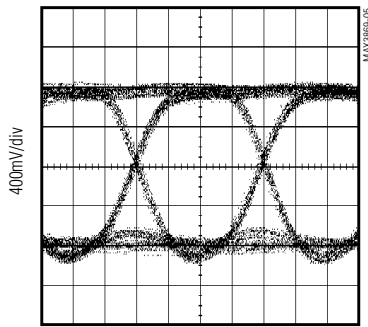

RANDOM JITTER vs. I_{MOD}

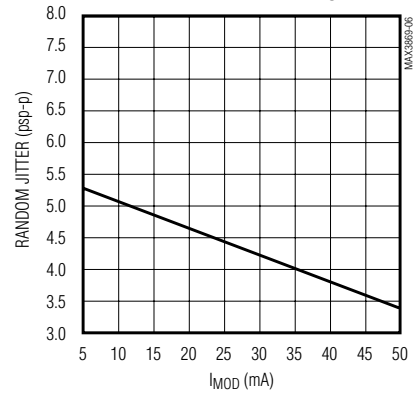

I_{BIAS}MAX vs. R_{BIAS}MAX

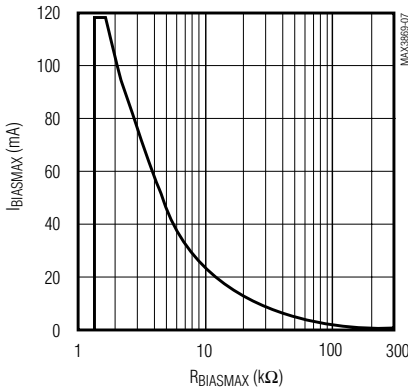

I_{MOD} vs. R_{MOD}SET

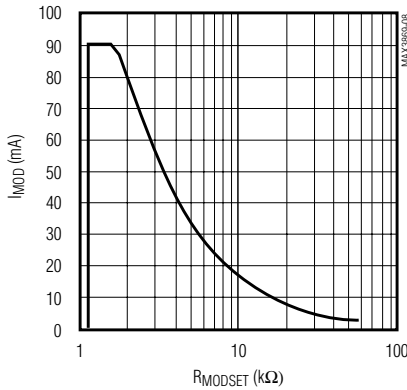

I_{MD} vs. R_{APC}SET

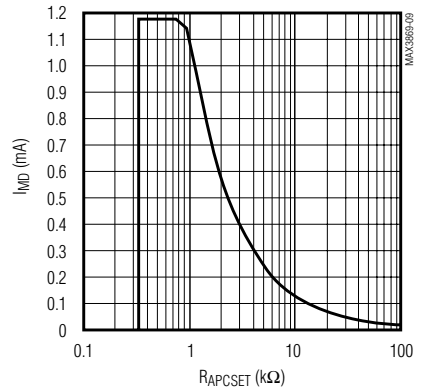

SUPPLY CURRENT vs. TEMPERATURE
(EXCLUDE I_{BIAS}, I_{MOD}, 25Ω LOAD)

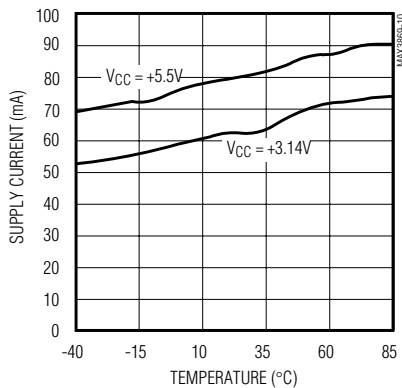

BIAS-CURRENT MONITOR GAIN vs. TEMPERATURE

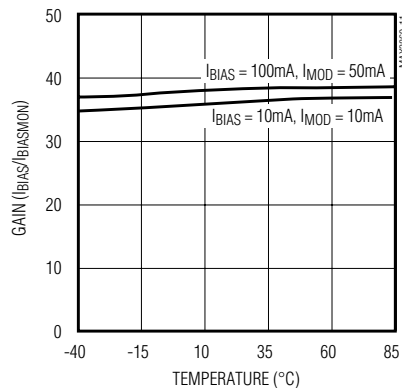

+3.3V, 2.5Gbps SDH/SONET Laser Driver with Current Monitors and APC

Typical Operating Characteristics (continued)

($V_{CC} = +3.3V$, load as shown in Figure 2, $T_A = +25^\circ C$, unless otherwise noted.)

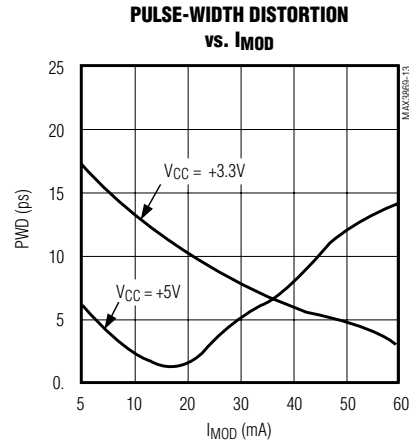
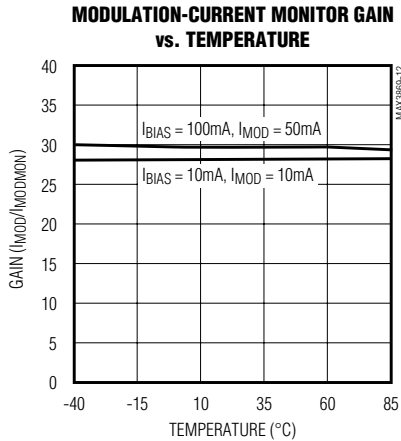

Pin Description

PIN	NAME	FUNCTION
1, 4, 7	V _{CC1}	Power Supply for Digital Circuits
2	DATA+	Noninverting PECL Input
3	DATA-	Inverting PECL Input
5	CLK+	Positive PECL Clock Input. Connect to V _{CC} if latch function is not used.
6	CLK-	Negative PECL Clock Input. Leave unconnected if latch function is not used.
8	LATCH	TTL/CMOS Latch Input. High for latched data, low for direct data. Internal 100kΩ pull-up to V _{CC} .
9	ENABLE	TTL/CMOS Enable Input. High for normal operation, low to disable laser bias and modulation current. Internal 100kΩ pull-up to V _{CC} .
10, 15	GND1	Ground for Digital Circuits
11	BIASMON	Bias Current Monitor. Sink current source that is proportional to the laser bias current.
12	MODMON	Modulation Current Monitor. Sink current source that is proportional to the laser modulation current.
13	FAIL	TTL/CMOS Failure Output. Indicates APC failure when low.
14	APCFILT	Connect a capacitor (C _{APCFILT} = 0.1μF) from this pad to ground to filter the APC noise.
16, 18, 21	V _{CC4}	Power Supply for Output Circuitry
17	BIAS	Laser Bias Current Output
19	OUT+	Positive Modulation-Current Output. I _{MOD} flows through this pad when input data is high.

+3.3V, 2.5Gbps SDH/SONET Laser Driver with Current Monitors and APC

MAX3869

Pin Description (continued)

PIN	NAME	FUNCTION
20	OUT-	Negative Modulation-Current Output. I_{MOD} flows through this pad when input data is low.
22	GND4	Ground for Output Circuitry
23	GND3	Ground for APC
24	MD	Monitor Diode Input. Connect this pad to a monitor photodiode anode. A capacitor to ground is required to filter high-speed AC monitor photocurrent.
25	V _{CC3}	Power Supply for APC
26	CAPC	A capacitor connected from this pad to ground controls the dominant pole of the APC feedback loop ($C_{APC} = 0.1\mu F$).
27	GND2	Ground for Internal Reference
28	N.C.	No Connection. Leave unconnected.
29	APCSET	A resistor connected from this pad to ground sets the desired average optical power. Connect 100k Ω from this pad to ground if APC is not used.
30	MODSET	A resistor connected from this pad to ground sets the desired modulation current.
31	BIASMAX	A resistor connected from this pad to ground sets the maximum bias current. The APC function can subtract from this maximum value, but cannot add to it.
32	V _{CC2}	Power Supply for Internal Reference

Detailed Description

The MAX3869 laser driver consists of two main parts: a high-speed modulation driver and a laser-biasing block with automatic power control (APC). The circuit design is optimized for both high-speed and low-voltage (+3.3V) operation. To minimize the pattern-dependent jitter of the input signal at speeds as high as 2.5Gbps, the device accepts a differential PECL clock signal for data retiming. When LATCH is high, the input data is synchronized by the clock signal. When LATCH is low, the input data is directly applied to the output stage.

The output stage is composed of a high-speed differential pair and a programmable modulation current source. Since the modulation output drives a maximum current of 60mA into the laser with an edge speed of 100ps, large transient voltage spikes can be generated (due to the parasitic inductance). These transients and the laser forward voltage leave insufficient headroom for the proper operation of the laser driver if the modulation output is DC-coupled to the laser diode. To solve this problem, the MAX3869's modulation output is designed to be AC-coupled to the cathode of a laser diode. An external pull-up inductor is necessary to DC-bias the modulation output at V_{CC}. Such a configuration isolates laser forward voltage from the output circuitry and

allows the output at OUT+ to swing above and below the supply voltage V_{CC}. A simplified functional diagram is shown in Figure 4.

The MAX3869 modulation output is optimized for driving a 25 Ω load; the minimum required voltage at OUT+ is 2.0V. Modulation current swings of 80mA are possible, but due to minimum power-supply and jitter requirements at 2.5Gbps, the specified maximum modulation current is limited to 60mA. To interface with the laser diode, a damping resistor (R_D) is required for impedance matching. An RC shunt network may also be necessary to compensate for the laser-diode parasitic inductance, thereby improving the optical output aberrations and duty-cycle distortion.

At the data rate of 2.5Gbps, any capacitive load at the cathode of a laser diode will degrade the optical output performance. Since the BIAS output is directly connected to the laser cathode, minimize the parasitic capacitance associated with this pin by using an inductor to isolate the BIAS pin from the laser cathode.

Automatic Power Control

To maintain constant average optical power, the MAX3869 incorporates an APC loop to compensate for the changes in laser threshold current over temperature and lifetime. A back-facet photodiode mounted in the

+3.3V, 2.5Gbps SDH/SONET Laser Driver with Current Monitors and APC

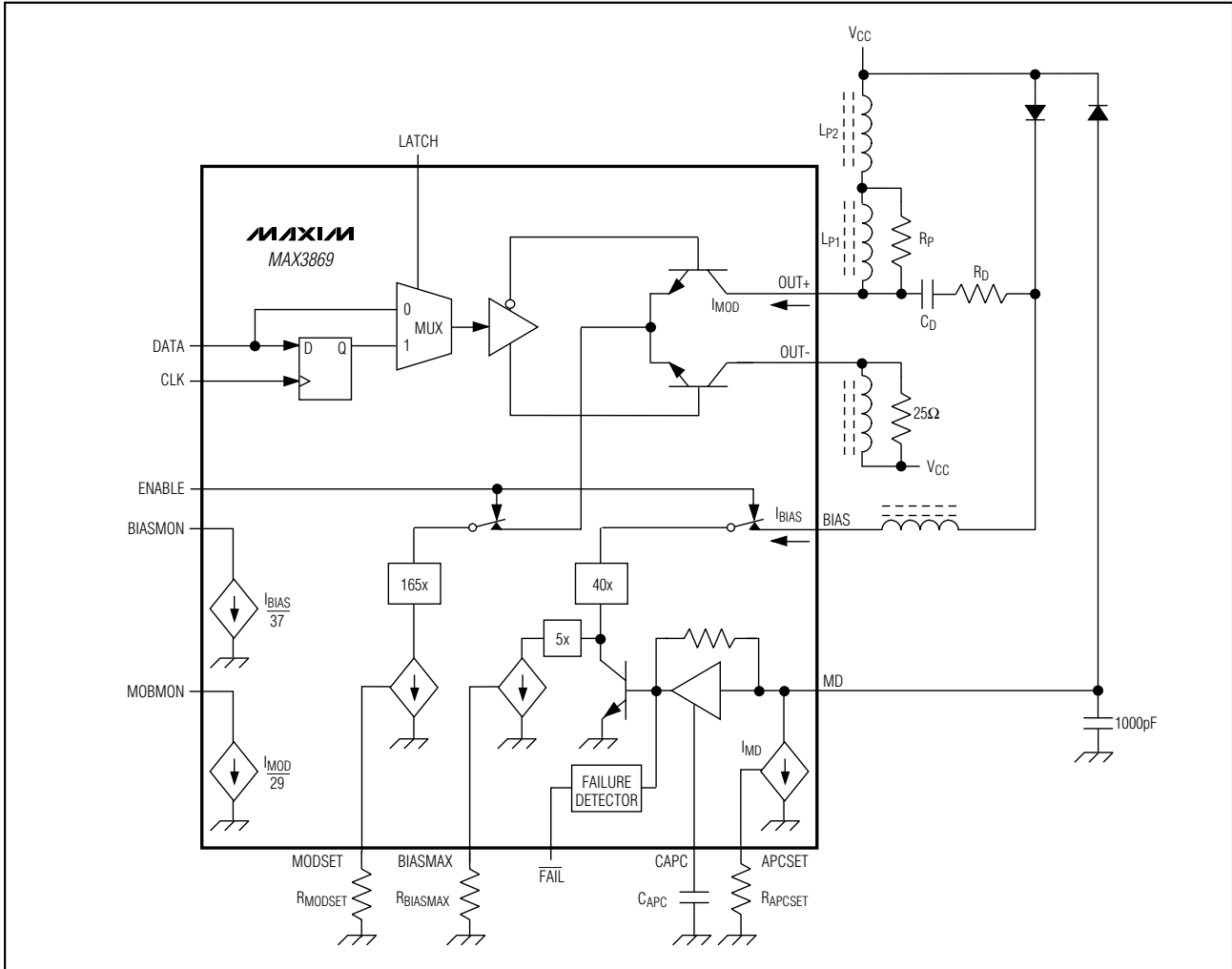

Figure 4. Functional Diagram

laser package is used to convert the optical power into a photocurrent. The APC loop adjusts the laser bias current so that the monitor current is matched to a reference current set by R_{APCSET}. The time constant of the APC loop is determined by an external capacitor (C_{APC}). To eliminate the pattern-dependent jitter associated with the APC loop-time constant, and to guarantee loop stability, the recommended value for C_{APC} is 0.1μF.

When the APC loop is functioning, the maximum allowable bias current is set by an external resistor, R_{BIASMAX}. An APC failure flag (FAIL) is set low when the bias current can no longer be adjusted to achieve the desired average optical power. To filter out the APC loop noise, use

an external capacitor at APC_{FILT} with a recommended value of 0.1μF.

APC closed-loop operation requires the user to set three currents with external resistors connected between ground and BIASMAX, MODSET, and APCSET. Detailed guidelines for these resistor settings are described in the *Design Procedure* section.

Open-Loop Operation

If necessary, the MAX3869 is fully operational without APC. In this case, the laser current is directly set by two external resistors connected from ground to BIASMAX and MODSET. See the *Design Procedure* section for more details on open-loop operation.

+3.3V, 2.5Gbps SDH/SONET Laser Driver with Current Monitors and APC

Optional Data Input Latch

To minimize input data pattern-dependent jitter, the differential clock signal should be connected to the data input latch, which is selected by an external LATCH control. If LATCH is high, the input data is retimed by the rising edge of CLK+. If LATCH is low, the input data is directly connected to the output stage. When this latch function is not used, connect CLK+ to V_{CC} and leave CLK- unconnected.

Enable Control

The MAX3869 incorporates a laser driver enable function. When ENABLE is low, both the bias and modulation currents are off. The typical laser enable time is 250ns, and the typical disable time is 25ns.

Current Monitors

The MAX3869 features bias- and modulation-current monitor outputs. The BIASMON output sinks a current equal to 1/37 of the laser bias current ($I_{BIAS} / 37$). The MODMON output sinks a current equal to 1/29 of the laser modulation current ($I_{MOD} / 29$). BIASMON and MODMON should be connected through a pull-up resistor to V_{CC}. Choose a pull-up resistor value that ensures a voltage at BIASMON greater than V_{CC} - 1.6V and a voltage at MODMON greater than V_{CC} - 1.0V.

Slow-Start

For laser safety reasons, the MAX3869 incorporates a slow-start circuit that provides a delay of 250ns for enabling a laser diode.

APC Failure Monitor

The MAX3869 provides an APC failure monitor (TTL/CMOS) to indicate an APC loop tracking failure. FAIL is set low when the APC loop can no longer adjust the bias current to maintain the desired monitor current.

Short-Circuit Protection

The MAX3869 provides short-circuit protection for the modulation, bias, and monitor current sources. If either BIASMAX, MODSET, or APCSET is shorted to ground, the bias and modulation output will be turned off.

Design Procedure

When designing a laser transmitter, the optical output is usually expressed in terms of average power and extinction ratio. Table 1 gives the relationships that are helpful in converting between the optical average power and the modulation current. These relationships are valid if the mark density and duty cycle of the optical waveform are 50%.

Programming the Modulation Current

For a given laser power P_{AVG}, slope efficiency η , and extinction ratio r_e , the modulation current can be calculated using Table 1. See the I_{MOD} vs. R_{MODSET} graph in the *Typical Operating Characteristics* and select the value of R_{MODSET} that corresponds to the required current at +25°C.

Programming the Bias Current

When using the MAX3869 in open-loop operation, the bias current is determined by the R_{BIASMAX} resistor. To select this resistor, determine the required bias current at +25°C. See the I_{BIASMAX} vs. R_{BIASMAX} graph in the *Typical Operating Characteristics* and select the value of R_{BIASMAX} that corresponds to the required current at +25°C.

When using the MAX3869 in closed-loop operation, the R_{BIASMAX} resistor sets the maximum bias current available to the laser diode over temperature and life. The APC loop can subtract from this maximum value but cannot add to it. See the I_{BIASMAX} vs. R_{BIASMAX} graph in the *Typical Operating Characteristics* and select the value of R_{BIASMAX} that corresponds to the end-of-life bias current at +85°C.

Programming the APC Loop

When the MAX3869's APC feature is used, program the average optical power by adjusting the APCSET resistor. To select this resistor, determine the desired monitor current to be maintained over temperature and life. See the I_{MD} vs. R_{APCSET} graph in the *Typical Operating Characteristics* and select the value of R_{APCSET} that corresponds to the required current.

Interfacing with Laser Diodes

To minimize optical output aberrations caused by signal reflections at the electrical interface to the laser diode, a series damping resistor (R_D) is required (Figure 4). Additionally, the MAX3869 outputs are optimized for a 25 Ω load. Therefore, the series combination of R_D and R_L (where R_L represents the laser-diode resistance)

Table 1. Optical Power Definition

PARAMETER	SYMBOL	RELATION
Average Power	P _{AVG}	$P_{AVG} = (P_0 + P_1) / 2$
Extinction Ratio	r_e	$r_e = P_1 / P_0$
Optical Power High	P ₁	$P_1 = 2P_{AVG} \cdot r_e / (r_e + 1)$
Optical Power Low	P ₀	$P_0 = 2P_{AVG} / (r_e + 1)$
Optical Amplitude	P _{p-p}	$P_{p-p} = 2P_{AVG} (r_e - 1) / (r_e + 1)$
Laser Slope Efficiency	η	$\eta = P_{p-p} / I_{MOD}$
Modulation Current	I _{MOD}	$I_{MOD} = P_{p-p} / \eta$

+3.3V, 2.5Gbps SDH/SONET Laser Driver with Current Monitors and APC

should equal 25Ω . Typical values for R_D are 18Ω to 23Ω . For best performance, a bypass capacitor ($0.01\mu\text{F}$ typical) should be placed as close as possible to the anode of the laser diode. Depending on the exact characteristics of the laser diode and PC board layout, a resistor (R_P) of 20Ω to 70Ω in parallel with pull-up inductor L_{P1} can be useful in damping overshoot and ringing in the optical output.

In some applications (depending on laser-diode parasitic inductance characteristics), an RC shunt network between the laser cathode and ground will help minimize optical output aberrations. Starting values for most coaxial lasers are $R = 75\Omega$ in series with $C = 3.3\text{pF}$. These values should be experimentally adjusted until the optical output waveform is optimized.

Pattern-Dependent Jitter

When transmitting NRZ data with long strings of consecutive identical digits (CIDs), LF droop can occur and contribute to pattern-dependent jitter (PDJ). To minimize this PDJ, three external components must be properly chosen: capacitor C_{APC} , which dominates the APC loop time constant; pull-up inductor L_P ; and AC-coupling capacitor C_D .

To filter out noise effects and guarantee loop stability, the recommended value for C_{APC} is $0.1\mu\text{F}$. This results in an APC loop bandwidth of 10kHz or a time constant of $16\mu\text{s}$. As a result, the PDJ associated with an APC loop time constant can be ignored.

The time constant associated with the output pull-up inductor ($L_P \approx L_{P2}$), and the AC-coupling capacitor (C_D) will also impact the PDJ. For such a second-order network, the PDJ due to the low frequency cutoff will be dominated by L_P . For a data rate of 2.5Gbps , the recommended value for C_D is $0.056\mu\text{F}$. During the maximum CID period t , it is recommended to limit the peak voltage droop to less than 12% of the average (6% of the amplitude). The time constant can be estimated by:

$$12\% = 1 - e^{-t/\tau_{LP}}$$

$$\tau_{LP} = 7.8t$$

If $\tau_{LP} = L_P / 25\Omega$, and $t = 100\text{UI} = 40\text{ns}$, then $L_P = 7.8\mu\text{H}$. To reduce the physical size of this element (L_P), use of SMD ferrite beads is recommended (Figure 2).

Input Termination Requirement

The MAX3869 data and clock inputs are PECL compatible. However, it is not necessary to drive the MAX3869 with a standard PECL signal. As long as the specified common-mode voltage and the differential voltage swings are met, the MAX3869 will operate properly.

Calculating Power Consumption

The junction temperature of the MAX3869 dice must be kept below $+150^\circ\text{C}$ at all times. The total power dissipation of the MAX3869 can be estimated by the following:

$$P = V_{CC} \cdot I_{CC} + (V_{CC} - V_f) \cdot I_{BIAS} \\ + I_{MOD} (V_{CC} - 25\Omega \cdot I_{MOD} / 2)$$

where I_{BIAS} is the maximum bias current set by $R_{BIAS-MAX}$, I_{MOD} is the modulation current, and V_f is the typical laser forward voltage.

$$\text{Junction Temperature} = P(\text{W}) \cdot 45 (\text{C/W})$$

Applications Information

An example of how to set up the MAX3869 follows.

Select Laser

A communication-grade laser should be selected for 2.488Gbps applications. Assume the laser output average power is $P_{AVG} = 0\text{dBm}$, minimum extinction ratio is $r_e = 6.6$ (8.2dB), the operating temperature is -40°C to $+85^\circ\text{C}$, and the laser diode has the following characteristics:

Wavelength:	$\lambda = 1.3\mu\text{m}$
Threshold Current:	$I_{TH} = 22\text{mA}$ at $+25^\circ\text{C}$
Threshold Temperature Coefficient:	$\beta_{TH} = 1.3\%/^\circ\text{C}$
Laser to Monitor Transfer:	$\rho_{MON} = 0.2\text{A/W}$
Laser Slope Efficiency:	$\eta = 0.05\text{mW/mA}$ at $+25^\circ\text{C}$

Determine R_{APCSET}

The desired monitor diode current is estimated by $I_{MD} = P_{AVG} \cdot \rho_{MON} = 200\mu\text{A}$. The I_{MD} vs. R_{APCSET} graph in the *Typical Operating Characteristics* shows that R_{APCSET} should be $6.0\text{k}\Omega$.

Determine R_{MODSET}

To achieve a minimum extinction ratio (r_e) of 6.6dB over temperature and lifetime, calculate the required extinction ratio at $+25^\circ\text{C}$. Assuming $r_e = 20$, the peak-to-peak optical power $P_{p-p} = 1.81\text{mW}$, according to Table 1. The required modulation current is $1.81(\text{mW}) / 0.05(\text{mW/mA}) = 36.2\text{mA}$. The I_{MOD} vs. R_{MODSET} graph in the *Typical Operating Characteristics* shows that R_{MODSET} should be $4.8\text{k}\Omega$.

+3.3V, 2.5Gbps SDH/SONET Laser Driver with Current Monitors and APC

MAX3869

Determine RBIASMAX

Calculate the maximum threshold current ($I_{TH(MAX)}$) at $T_A = +85^\circ\text{C}$ and end of life. Assuming $I_{TH(MAX)} = 50\text{mA}$, the maximum bias current should be:

$$I_{BIASMAX} = I_{TH(MAX)} + I_{MOD}/2$$

In this example, $I_{BIASMAX} = 68.1\text{mA}$. The $I_{BIASMAX}$ vs. $R_{BIASMAX}$ graph in the *Typical Operating Characteristics* shows that $R_{BIASMAX}$ should be $3.2\text{k}\Omega$.

Modulation Currents Exceeding 60mA

With a +5V power supply, the headroom voltage for the MAX3869 is significantly improved. In this case, it is possible to achieve a modulation current of more than 60mA with AC-coupling, if the junction temperature is kept below 150°C . The MAX3869 can also be DC-coupled to a laser diode when operating with a +5V supply; the voltage at OUT+ should be $\geq 2.0\text{V}$ for proper operation.

Wire Bonding Die

For high current density and reliable operation, the MAX3869 uses gold metalization. Make connections to the die with gold wire only, using ball-bonding techniques. Wedge bonding is not recommended. Die-pad size is 4 mils ($100\mu\text{m}$) square, and die thickness is 12 mils ($300\mu\text{m}$) square.

Layout Considerations

To minimize inductance, keep the connections between the MAX3869 output pins and LD as close as possible. Optimize the laser diode performance by placing a bypass capacitor as close as possible to the laser anode. Use good high-frequency layout techniques and multilayer boards with uninterrupted ground planes to minimize EMI and crosstalk.

Laser Safety and IEC 825

Using the MAX3869 laser driver alone does not ensure that a transmitter design is compliant with IEC 825. The entire transmitter circuit and component selections must be considered. Each customer must determine the level of fault tolerance required by their application, recognizing that Maxim products are not designed or authorized for use as components in systems intended for surgical implant into the body, for applications intended to support or sustain life, or for any other application where the failure of a Maxim product could create a situation where personal injury or death may occur.

Chip Information

TRANSISTOR COUNT: 1561

SUBSTRATE CONNECTED TO GND

+3.3V, 2.5Gbps SDH/SONET Laser Driver with Current Monitors and APC

Pin Configuration

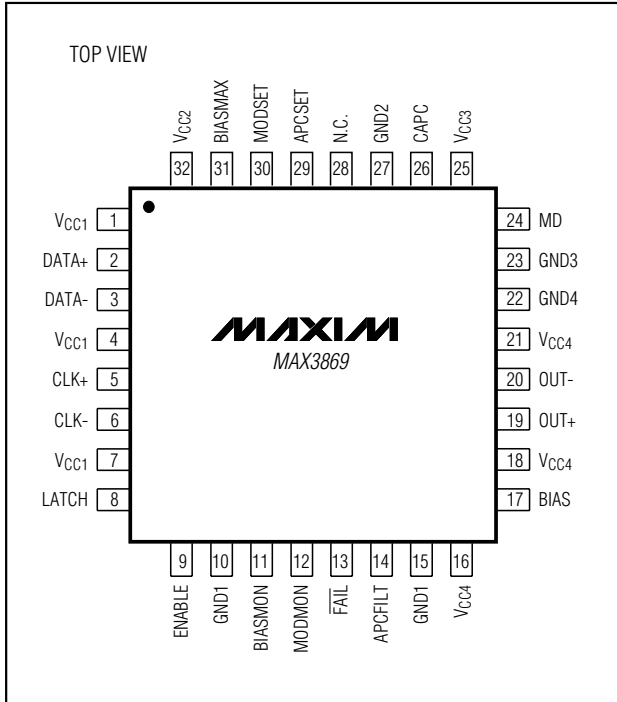

Chip Topography

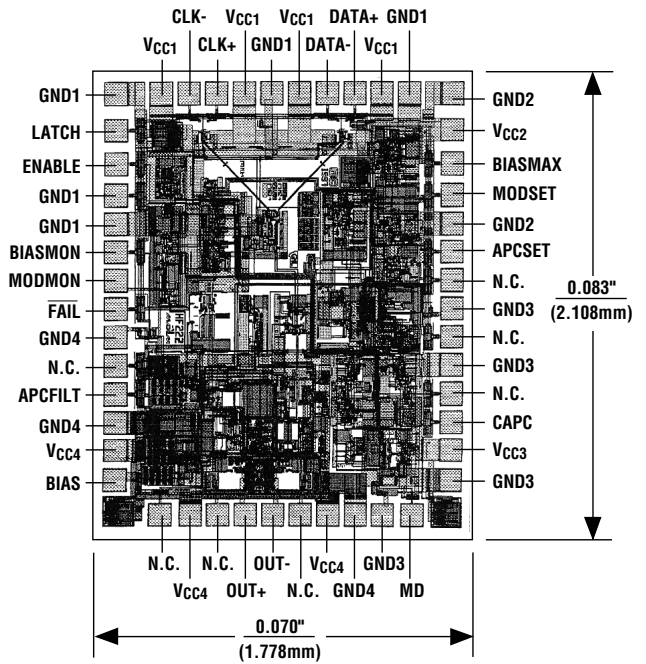

+3.3V, 2.5Gbps SDH/SONET Laser Driver with Current Monitors and APC

Package Information

MAX3869

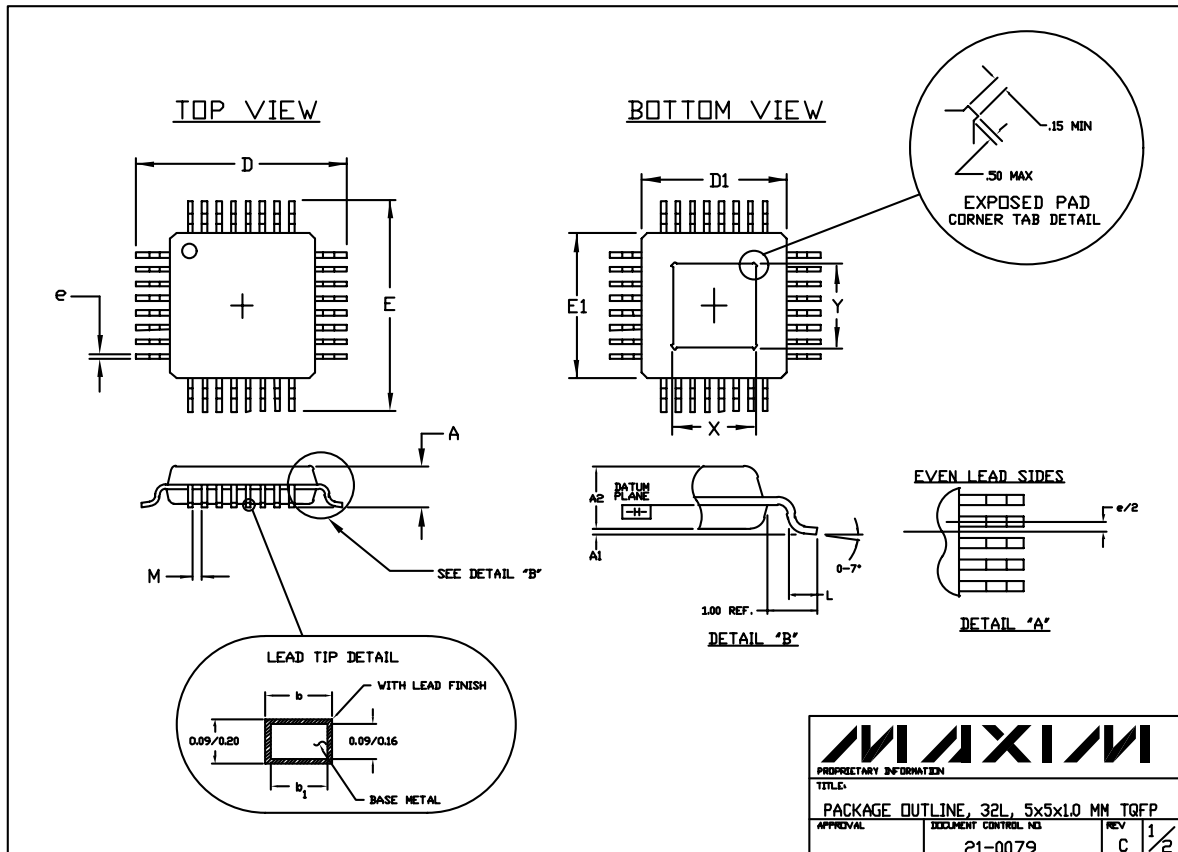

+3.3V, 2.5Gbps SDH/SONET Laser Driver with Current Monitors and APC

Package Information (continued)

NOTES:

1. ALL DIMENSIONING AND TOLERANCING CONFORM TO ANSI Y14.5-1982.
2. DATUM PLANE [EE] IS LOCATED AT MOLD PARTING LINE AND COINCIDENT WITH LEAD, WHERE LEAD EXITS PLASTIC BODY AT BOTTOM OF PARTING LINE.
3. DIMENSIONS D1 AND E1 DO NOT INCLUDE MOLD PROTRUSION. ALLOWABLE MOLD PROTRUSION IS 0.254 MM ON D1 AND E1 DIMENSIONS.
4. THE TOP OF PACKAGE IS SMALLER THAN THE BOTTOM OF PACKAGE BY 0.15 MILLIMETERS.
5. DIMENSION b DOES NOT INCLUDE DAMBAR PROTRUSION. ALLOWABLE DAMBAR PROTRUSION SHALL BE 0.08 MM TOTAL IN EXCESS OF THE b DIMENSION AT MAXIMUM MATERIAL CONDITION.
6. CONTROLLING DIMENSION: MILLIMETER.
7. THIS OUTLINE CONFORMS TO JEDEC PUBLICATION 95, REGISTRATION MO-136.
8. EXPOSED DIE PAD SHALL BE COPLANAR WITH BOTTOM OF PACKAGE WITHIN 2 MILS (.05 MM).
9. LEADS SHALL BE COPLANAR WITHIN .004 INCH.
10. DIMENSIONS X AND Y APPLY TO EXPOSED PAD VERSIONS ONLY.

JEDEC VARIATIONS				
DIMENSIONS IN MILLIMETERS				
AA		AA-EP*		
5x5x1.0 MM		5x5x1.0 MM		
	MIN.	MAX.	MIN.	MAX.
A	<i>~</i>	1.20	<i>~</i>	1.20
A ₁	0.05	0.15	0.05	0.15
A ₂	0.95	1.05	0.95	1.05
D	7.00 BSC.		7.00 BSC.	
D ₁	5.00 BSC.		5.00 BSC.	
E	7.00 BSC.		7.00 BSC.	
E ₁	5.00 BSC.		5.00 BSC.	
L	0.45	0.75	0.45	0.75
M	0.15	<i>~</i>	0.15	<i>~</i>
N	32		32	
e	0.50 BSC.		0.50 BSC.	
b	0.17	0.27	0.17	0.27
b1	0.17	0.23	0.17	0.23
X	N/A	N/A	2.70	3.30
Y	N/A	N/A	2.70	3.30

* EXPOSED PAD

MAXIM			
<small>PROPRIETARY INFORMATION</small>			
<small>TITLE</small>			
PACKAGE OUTLINE, 32L, 5x5x1.0 MM TQFP			
<small>APPROVAL</small>	<small>DOCUMENT CONTROL NO.</small>	<small>REV</small>	<small>2/2</small>
	21-0079	C	

**+3.3V, 2.5Gbps SDH/SONET Laser Driver
with Current Monitors and APC**

NOTES

MAX3869

+3.3V, 2.5Gbps SDH/SONET Laser Driver with Current Monitors and APC

NOTES

Maxim makes no warranty, representation or guarantee regarding the suitability of its products for any particular purpose, nor does Maxim assume any liability arising out of the application or use of any product or circuit and specifically disclaims any and all liability, including without limitation consequential or incidental damages. "Typical" parameters can and do vary in different applications. All operating parameters, including "typicals" must be validated for each customer application by customer's technical experts. Maxim products are not designed, intended or authorized for use as components in systems intended for surgical implant into the body, or other applications intended to support or sustain life, or for any other application in which the failure of the Maxim product could create a situation where personal injury or death may occur.

16 _____ **Maxim Integrated Products, 120 San Gabriel Drive, Sunnyvale, CA 94086 408-737-7600**