

# MAXIM

## High-Side Power Supplies

MAX622/MAX623

### General Description

The MAX622/MAX623 high-side power supplies, using a regulated charge-pump, generate a regulated output voltage 11V greater than the input supply voltage to power high-side switching and control circuits. The MAX622/MAX623 allow low-resistance N-Channel MOSFETs (FETs) to be used in circuits that normally require costly, less efficient P-Channel FETs and PNP transistors. The high-side output also eliminates the need for logic FETs in +5V and other low-voltage switching circuits.

A +3.5V to +16.5V input supply range and a typical quiescent current of only 70µA make the MAX622/MAX623 ideal for a wide range of line- and battery-powered switching and control applications where efficiency is crucial. Also provided is a logic-level Power-Ready Output (PR) to indicate when the high-side voltage reaches the proper level.

The MAX622 comes in 8-pin DIP and SO packages and requires three inexpensive external capacitors. The MAX623 is supplied in 16-pin DIPs only, but contains internal capacitors and requires no external components.

### Applications

- High-Side Power Control with N-Channel FETs
- Low-Dropout Voltage Regulators
- Power Switching from Low Supply Voltages
- H-Switches
- Stepper Motor Drivers
- Battery-Load Management
- Portable Computers

### Typical Operating Circuit

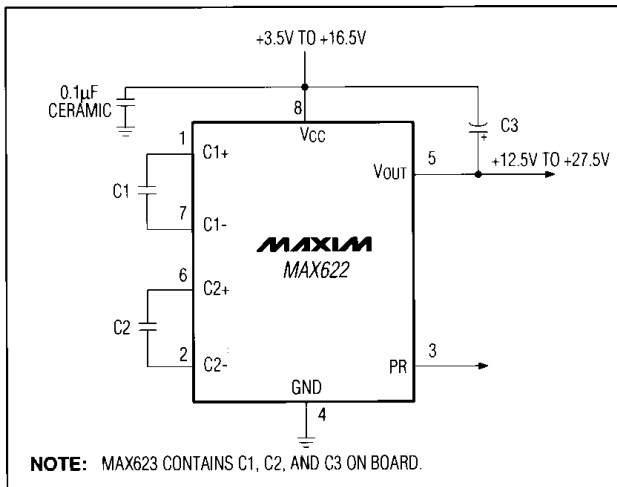

### Features

- ◆ +3.5V to +16.5V Operating Supply Voltage Range
- ◆ Output Voltage Regulated to  $V_{CC} + 11V$  (Typ)
- ◆ 70µA Typ Quiescent Current
- ◆ Power-Ready Output

### Ordering Information

PART	TEMP. RANGE	PIN-PACKAGE
MAX622CPA	0°C to +70°C	8 Plastic DIP
MAX622CSA	0°C to +70°C	8 SO
MAX622C/D	0°C to +70°C	Dice*
MAX622EPA	-40°C to +85°C	8 Plastic DIP
MAX622ESA	-40°C to +85°C	8 SO
MAX623CPE	0°C to +70°C	16 Plastic DIP
MAX623EPE	-40°C to +85°C	16 Plastic DIP

\*Contact factory for dice specifications.

### Pin Configurations

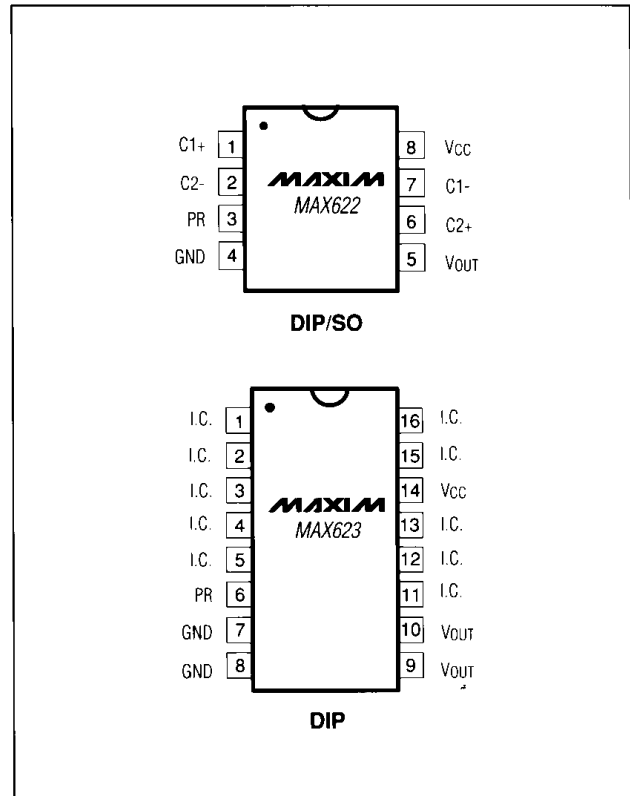

# High-Side Power Supplies

## ABSOLUTE MAXIMUM RATINGS

V <sub>CC</sub> .....	+17V
V <sub>OUT</sub> .....	+30V
I <sub>OUT</sub> .....	25mA
Continuous Total Power Dissipation (T <sub>A</sub> = +70°C)	
8-pin Plastic DIP (derate 6.9mW/°C above +70°C) . . .	552mW
8-pin SO (derate 5.88mW/°C above +70°C) . . . . .	471mW
16-pin Plastic DIP (derate 7.41mW/°C above +70°C) .	593mW

### Operating Temperature Ranges:

MAX62_C _ _ .....	0°C to +70°C
MAX62_E _ _ .....	-40°C to +85°C
Storage Temperature Range .....	-65°C to +160°C
Lead Temperature (soldering, 10 sec) .....	+300°C

Stresses beyond those listed under "Absolute Maximum Ratings" may cause permanent damage to the device. These are stress ratings only, and functional operation of the device at these or any other conditions beyond those indicated in the operational sections of the specifications is not implied. Exposure to absolute maximum rating conditions for extended periods may affect device reliability.

## ELECTRICAL CHARACTERISTICS (MAX622)

(V<sub>CC</sub> = +5V, T<sub>A</sub> = T<sub>MIN</sub> to T<sub>MAX</sub>, unless otherwise noted.)

PARAMETER	SYMBOL	CONDITIONS	MIN	TYP	MAX	UNITS
Supply Voltage	V <sub>CC</sub>		3.5		16.5	V
High-Side Voltage (Note 1)	V <sub>OUT</sub>	I <sub>OUT</sub> = 0, V <sub>CC</sub> = 3.5V, C1 = C2 = 0.047μF, C3 = 1μF	11.5	12.5	16.5	V
		I <sub>OUT</sub> = 0, V <sub>CC</sub> = 4.5V, C1 = C2 = 0.047μF, C3 = 1μF	14.5	15.5	17.5	
		I <sub>OUT</sub> = 0, V <sub>CC</sub> = 16.5V, C1 = C2 = 0.01μF, C3 = 1μF (Note 2)	26.5	27.5	29.5	
		I <sub>OUT</sub> = 50μA, V <sub>CC</sub> = 3.5V, C1 = C2 = 0.047μF, C3 = 1μF	8.5	10.5	16.5	
		I <sub>OUT</sub> = 250μA, V <sub>CC</sub> = 5V, C1 = C2 = 0.047μF, C3 = 1μF	15		18	
		I <sub>OUT</sub> = 500μA, V <sub>CC</sub> = 16.5V, C1 = C2 = 0.01μF, C3 = 1μF (Note 2)	26.5		29.5	
Power-Ready Threshold	PRT	I <sub>OUT</sub> = 0 (Note 3)	12	13.5	14.5	V
Power-Ready Output High	PROH	I <sub>SOURCE</sub> = 100μA	3.8	4.3	5	V
Power-Ready Output Low	PROL	I <sub>SINK</sub> = 1mA			0.4	V
Output Voltage Ripple	VR	C1 = C2 = 0.01μF, C3 = 10μF, I <sub>OUT</sub> = 1mA, V <sub>CC</sub> = 16.5V		50		mV
Switching Frequency	F <sub>O</sub>			90		kHz
Quiescent Supply Current	I <sub>Q</sub>	I <sub>OUT</sub> = 0, V <sub>CC</sub> = 5V, C1 = C2 = 0.047μF, C3 = 1μF, T <sub>A</sub> = +25°C		70	500	μA
		I <sub>OUT</sub> = 0, V <sub>CC</sub> = 16.5V, C1 = C2 = 0.047μF, C3 = 1μF, T <sub>A</sub> = +25°C		70	350	

# High-Side Power Supplies

MAX622/MAX623

## ELECTRICAL CHARACTERISTICS (MAX623)

(VCC = +5V, TA = TMIN to TMAX, unless otherwise noted.)

PARAMETER	SYMBOL	CONDITIONS	MIN	TYP	MAX	UNITS
Supply Voltage	VCC		3.5		16.5	V
High-Side Voltage (Note 1)	VOUT	IOUT = 0, VCC = 3.5V	11.5	12.5	16.5	V
		IOUT = 0, VCC = 4.5V	14.5	15.5	17.5	
		IOUT = 0, VCC = 16.5V	26.5	27.5	29.5	
		IOUT = 50μA, VCC = 3.5V	8.5	10.5	16.5	
		IOUT = 250μA, VCC = 5V	15		18	
		IOUT = 500μA, VCC = 16.5V	26.5		29.5	
Power-Ready Threshold	PRT	IOUT = 0 (Note 3)	12	13.5	14.5	V
Power-Ready Output High	PROH	ISOURCE = 100μA	3.8	4.3	5	V
Power-Ready Output Low	PROL	ISINK = 1mA			0.4	V
Output Voltage Ripple	VR	IOUT = 500μA (Note 4)		100		mV
Switching Frequency	FO			90		kHz
Quiescent Supply Current	IQ	IOUT = 0, VCC = 5V, TA = +25°C		70	500	μA
		IOUT = 0, VCC = 16.5V, TA = +25°C		70	350	

**Note 1:** High-Side Voltage measured with respect to ground.

**Note 2:** For VCC > +13V on the MAX622, use C1 = C2 = 0.01μF.

**Note 3:** Power-Ready Threshold is the voltage with respect to ground at VOUT when PR switches high (PR = VCC).

**Note 4:** Output Voltage Ripple on the MAX623 may be reduced by adding an external 10μF reservoir capacitor.

## Pin Description

MAX622 8-PIN	MAX623 16-PIN	NAME	FUNCTION
1		C1+	Positive terminal to primary charge-pump capacitor.
	1-5, 11-13, 15, 16	I.C.	Internal Connection. Make no connection to this pin.
2		C2-	Negative terminal to secondary charge-pump capacitor.
3	6	PR	Power-Ready Output. High when VOUT is ≥ VCC + 8.5V with respect to GND.
4	7, 8	GND	Ground
5	9, 10	VOUT	High-Side Voltage Out
6		C2+	Positive terminal to secondary charge-pump capacitor.
7		C1-	Negative terminal to primary charge-pump capacitor
8	14	VCC	Input Supply

# High-Side Power Supplies

## Typical Operating Characteristics

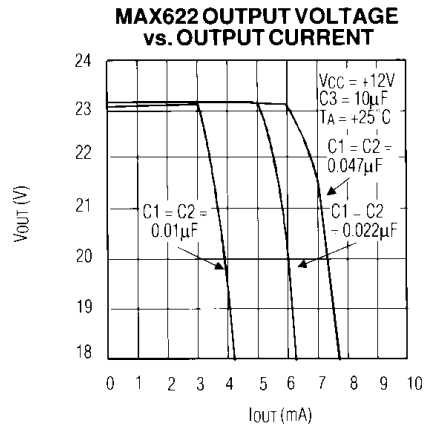
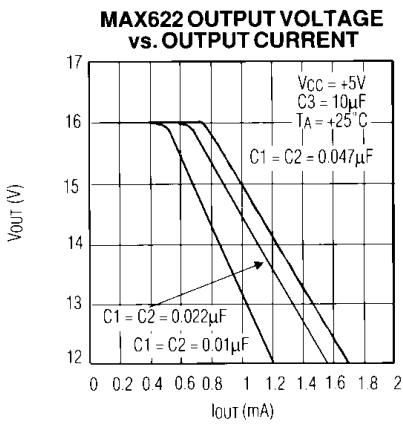
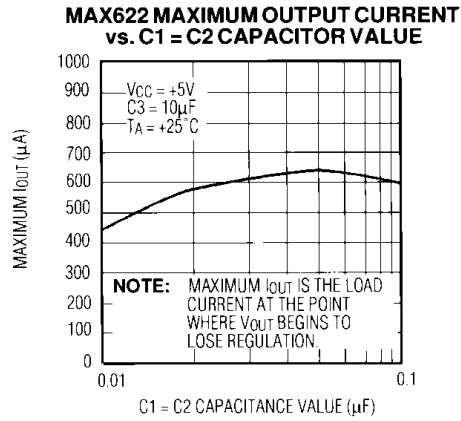
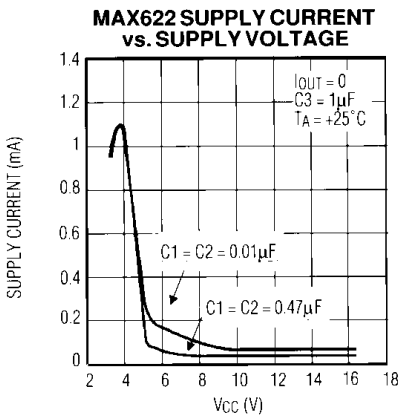
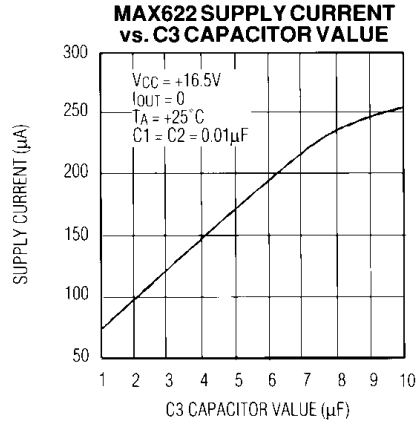
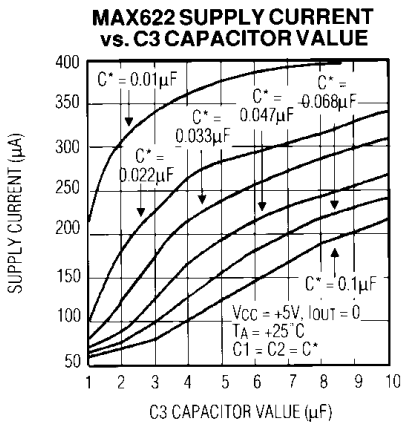

# High-Side Power Supplies

## Typical Operating Characteristics (continued)

MAX622/MAX623

**MAX622 OUTPUT VOLTAGE RIPPLE vs. RESERVOIR CAPACITOR C3**

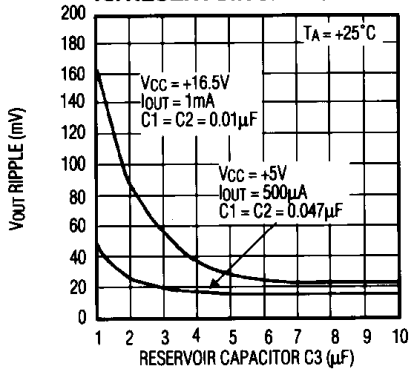

**MAX622/MAX623 TURN-ON TIME vs. SUPPLY VOLTAGE**

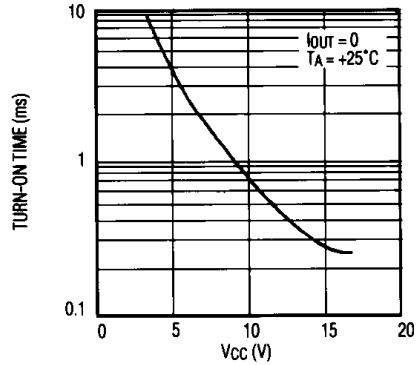

**MAX623 SUPPLY CURRENT vs. SUPPLY VOLTAGE**

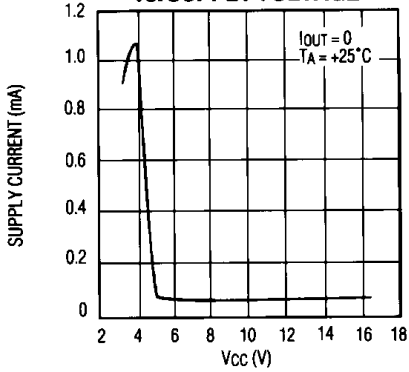

**MAX623 OUTPUT VOLTAGE RIPPLE vs. SUPPLY VOLTAGE**

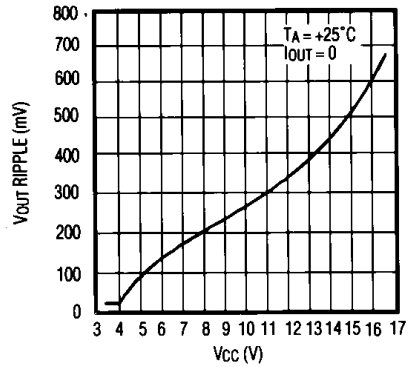

**MAX623 OUTPUT VOLTAGE vs. OUTPUT CURRENT**

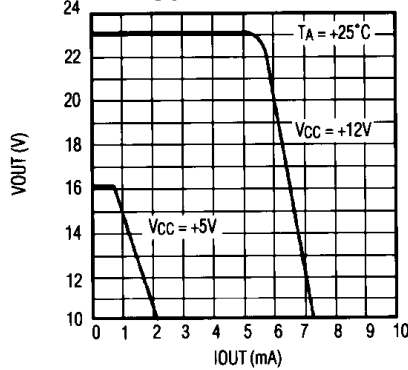

# High-Side Power Supplies

## Detailed Description

### Charge-Pump Operation

The MAX622/MAX623 are multi-stage charge-pump power supplies. Although the charge pumps are capable of multiplying  $V_{CC}$  up to four times, the outputs are regulated to  $V_{CC}+11V$  by an internal feedback circuit for inputs above 4V. The charge pumps typically operate at 90kHz, but regulate by pulse-skipping. When  $V_{OUT}$  exceeds  $V_{CC}+11V$ , the oscillator shuts off. As  $V_{OUT}$  dips below  $V_{CC}+11V$ , the oscillator turns on.

### Power-Ready Output

The Power-Ready Output (PR) signals control circuitry when the high-side voltage reaches a preset level. This feature can be used to protect external FET switches from excess dissipation and damage by preventing them from turning on, except when adequate gate drive levels are present. When power is applied, PR remains low until  $V_{OUT}$  reaches approximately  $V_{CC} + 8.5V$ . PR also goes low if  $V_{OUT}$  falls below this level during operation, i.e. if the output is overloaded. The PR high level is  $V_{CC}$ .

## Application Hints

### Quiescent Supply Current

MAX622 quiescent supply current varies with  $V_{CC}$  and with the values of  $C1$ ,  $C2$ , and  $C3$  (*Typical Operating Characteristics*). Even with no external load, the device must still pump to overcome internal losses. Larger ratios between  $C3$  and  $C1$  or  $C2$  require more charge-pump cycles to restore  $V_{OUT}$ . The MAX623 with internal capacitors is not subject to supply-current variations with capacitor ratio. As  $V_{CC}$  falls below 5V, quiescent current rises fairly rapidly to about 1mA at 4V (*Typical Operating Characteristics*). This rise occurs because  $V_{OUT}$  no longer pulse-skips to regulate at low input voltages; the oscillator runs continuously, so supply current is higher. Figure 2 shows the test circuits for the MAX622/MAX623 quiescent supply current.

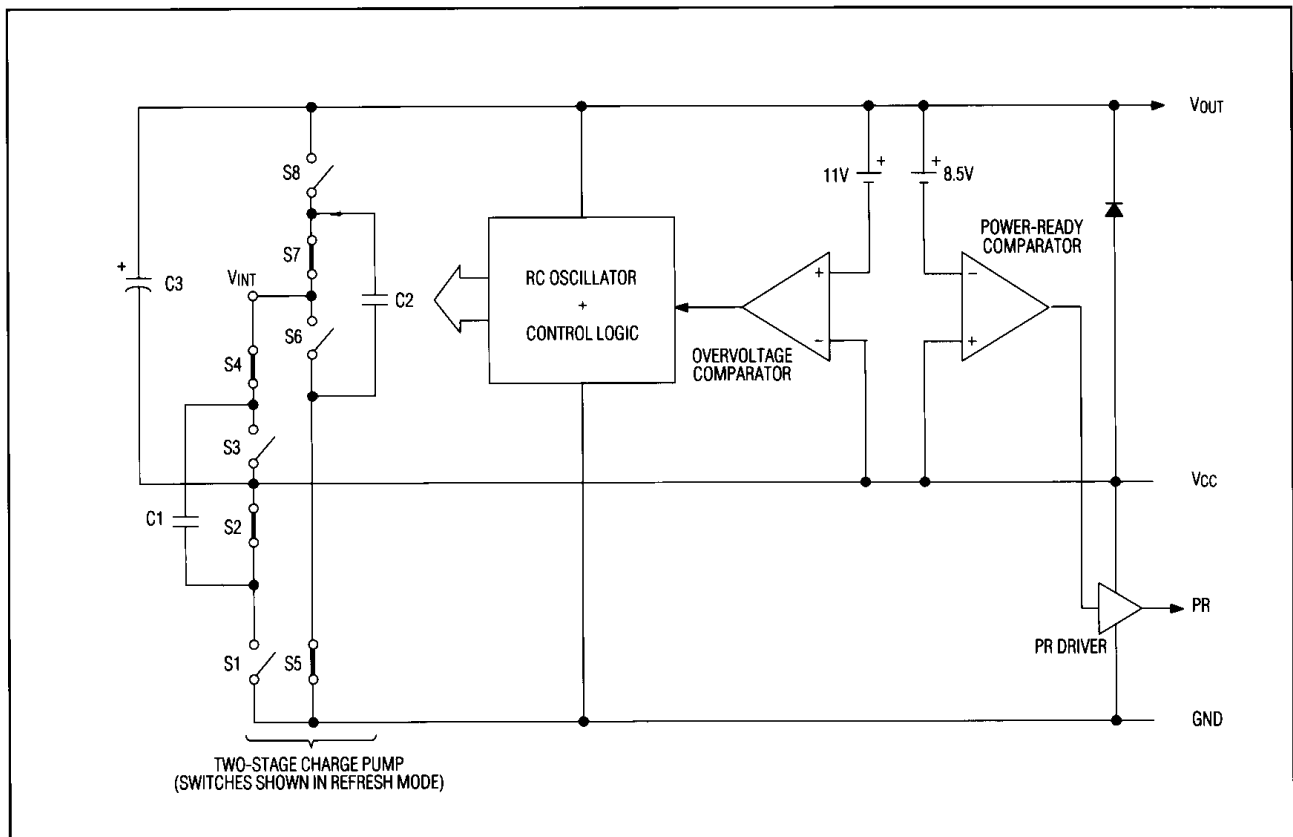

Figure 1. MAX622/MAX623 Block Diagram

# High-Side Power Supplies

### Output Ripple

V<sub>OUT</sub> ripple is typically 50mV peak-to-peak with V<sub>CC</sub> = +5V, C1 and C2 = 0.047μF, and C3 = 1μF (*Typical Operating Characteristics*). Ripple can be reduced by increasing the ratio between the output storage capacitor C3 and C1 and C2. This is usually accomplished by increasing C3 and keeping C1 and C2 in the 0.01μF to 0.047μF range. For example, if C1 and C2 are 0.047μF (V<sub>CC</sub> must not exceed 13V) and C3 is 10μF, output ripple typically falls to 15mV (*Typical Operating Characteristics*). Similarly, MAX623 output ripple is reduced by adding an external storage capacitor from V<sub>OUT</sub> to V<sub>CC</sub>.

### Capacitor Selection

Capacitor type is unimportant when selecting capacitors for the MAX622. However, when V<sub>CC</sub> exceeds 13V, C1 and C2 must be no greater than 0.01μF. Using larger value capacitors with input voltages above 13V causes excessive amounts of energy to pass through internal

switches during charge-pump cycles. This may damage the device.

### Output Protection

The MAX622/MAX623 are not internally short-circuit protected. In applications where the output is susceptible to short circuit, external output short-circuit protection must be provided. Accomplish this by connecting a resistor between V<sub>OUT</sub> and the load to limit output current to less than 25mA. The resistor value is determined by the following formula:

$$R_{CL} \geq \frac{V_{CC}}{25mA}$$

### Typical Applications

#### Simple Single-Load Switch

A single switch can be made with the MAX622/MAX623 and a MAX480 op amp configured as a comparator

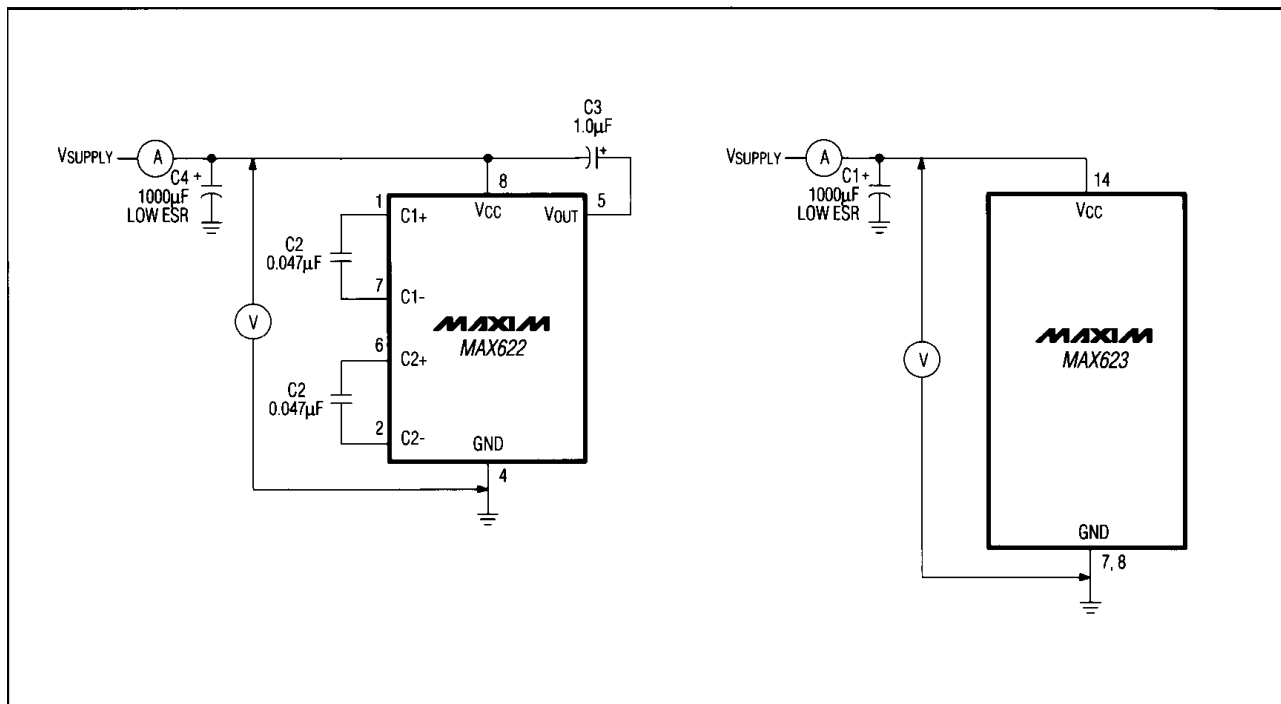

Figure 2. MAX622/MAX623 Quiescent Supply-Current Test Circuits

## High-Side Power Supplies

(Figure 3). The switch is turned on by applying  $V_{BATT}$  to the ON/OFF input and turned off by pulling it to GND.

### One MAX622 Drives Six High-Side Switches

Multiple subsystems or modules can be turned on and off using a single MAX622 and an open-drain hex buffer such as the 74C906 (Figure 4). The drains of all buffer outputs are pulled up through resistors to the MAX622's  $V_{OUT}$ . The pull-up resistance depends on the number of channels being used with the MAX622/MAX623 and power-dissipation limitations. The minimum pull-up resistor value is determined by the number of channels paralleled on each high-side power supply and the high-side output current from the MAX622/MAX623 at a given supply voltage, calculated as follows:

$$R_{MIN} = \frac{V_{OUT} \times (\text{number of channels})}{I_{OUT}}$$

where  $V_{OUT}$  is the high-side output voltage and  $I_{OUT}$  is the output current of the MAX622.

For example, assuming an output current of 1mA and six channels, as in Figure 4, the minimum pull-up resistor value that will not excessively load the MAX622 is about 100k $\Omega$ , assuming all six channels are pulled low at the same time. The value of the pull-up resistor also affects the turn-on time of each FET, and hence the amount of

energy dissipated in the FET during turn on. The rate of rise of  $V_{GS}$  is limited by the RC time constant of the pull-up resistor and FET gate capacitance; waste power will be dissipated in the FET equal to  $(I_{LOAD})^2 \times r_{DS}$  during the RC time period.

### H-Bridge Motor Driver

An H-bridge motor driver is shown in Figure 5. The motor direction can be controlled by toggling between IN1 and IN2 of the DG303 analog switch. Each switch section turns on the appropriate FET pair which passes current through the motor in the desired direction.

### Battery-Load Controller

In Figure 6, a MAX8211 undervoltage detector detects the battery's end-of-life, and a MAX622 high-side power supply turns the power FET switch on. During normal operation, the MAX8211 Hysteresis pin powers the MAX622, providing gate-drive to keep the FET off. When the battery reaches its discharge threshold (end-of-life), the MAX8211 output pulls the FET gate low, cutting off current to the load. At the same time, the Hysteresis pin goes low, turning off the MAX622. As a result, supply current is approximately 10 $\mu$ A in the load-disconnected condition.

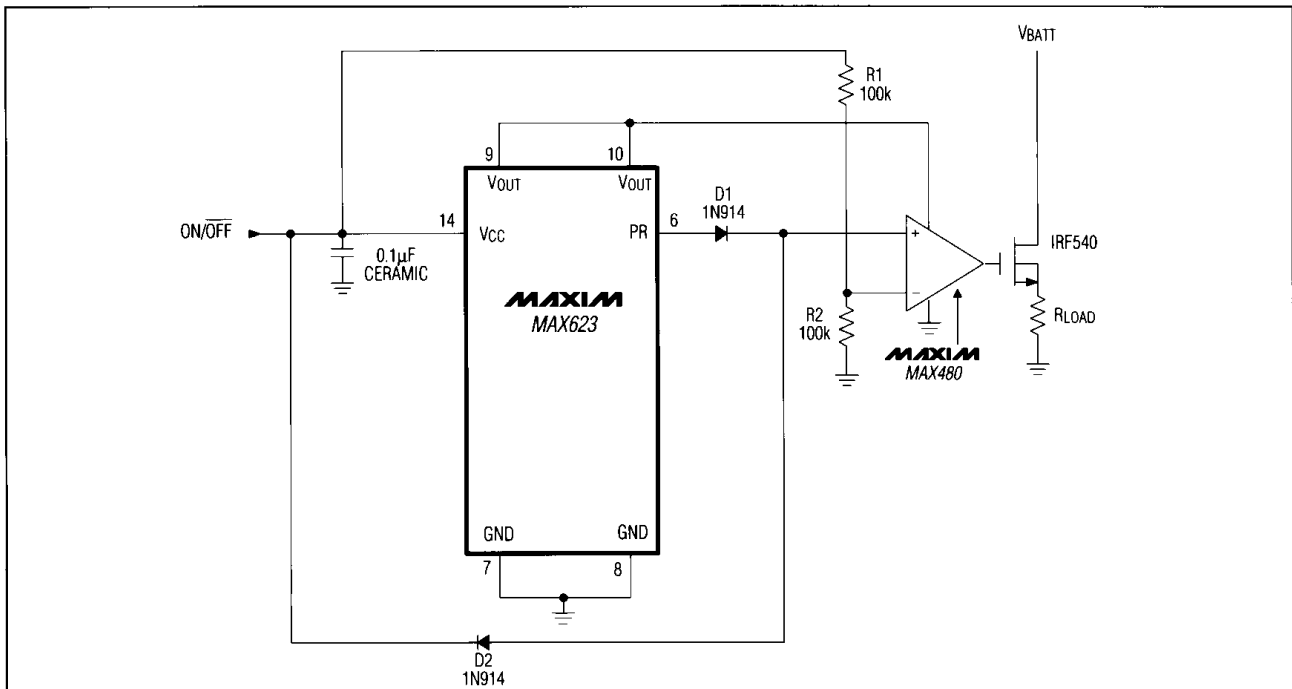

Figure 3. Single-Load Switch



# High-Side Power Supplies

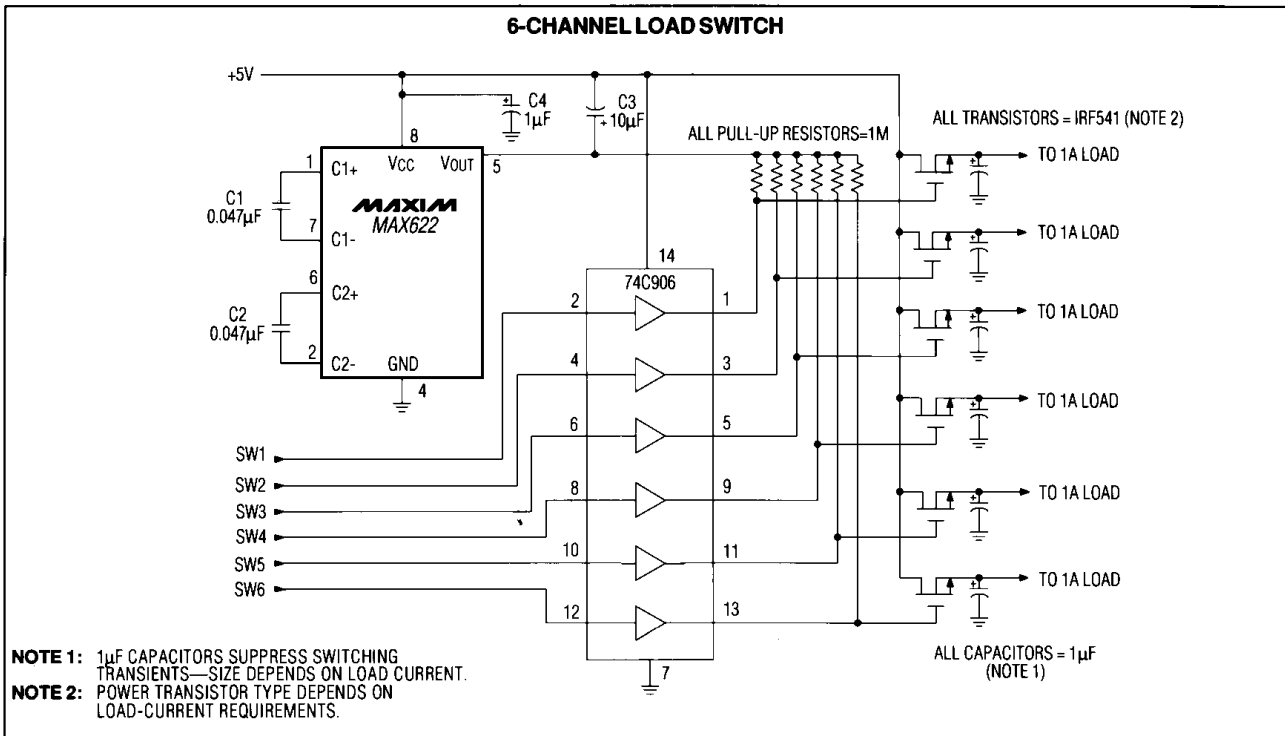

Figure 4. A Single MAX622 Drives Six High-Side Switches

## 4-Channel Load Switch With No Pull-Up Resistors

Multiple high-side switches can be driven from a single MAX622/MAX623 high-side power supply with no pull-up resistors on the FET gates. In Figure 7, a MAX622 supplies high-side voltage to a MAX333 quad analog switch to control any one of four high-side switches. The FET gates are normally connected to ground when the MAX333 logic inputs are low.

## Low-Dropout Regulator

In Figure 8, a MAX622 high-side power supply powers an LM10 reference and op-amp combination, providing sufficient gate drive to turn on the FET. This allows the regulator to achieve less than 70mV dropout at 1A load using an IRF541, and just under 20mV for a SMP60N06.

The 200mV reference section is configured for a gain of 25 (e.g. 200mV x 25 = 5V) and connects to the noninverting input of the op amp; the regulator's output connects directly to the inverting input. The op amp amplifies the error between its inputs and varies the gate drive to the FET, regulating the output. Capacitor C6 reduces transients due to load changes; its size depends on the

magnitude of the load change in the application and can be reduced or eliminated if the load remains relatively constant. With C6 = 1000µF, the output transient to a 1A load pulsed at 20Hz is typically less than 150mV. The regulator is turned on by applying VBATT to the Enable/Shutdown input and turned off by pulling this input to ground.

The regulator output voltage, VOUT, is set by the ratio of R1 to R2, calculated as follows:

$$R2 = R1 \left( \frac{V_{OUT}}{0.2} - 1 \right)$$

If the application does not require logic shutdown, connect the MAX622 VCC pin directly to the battery and eliminate D2.

# High-Side Power Supplies

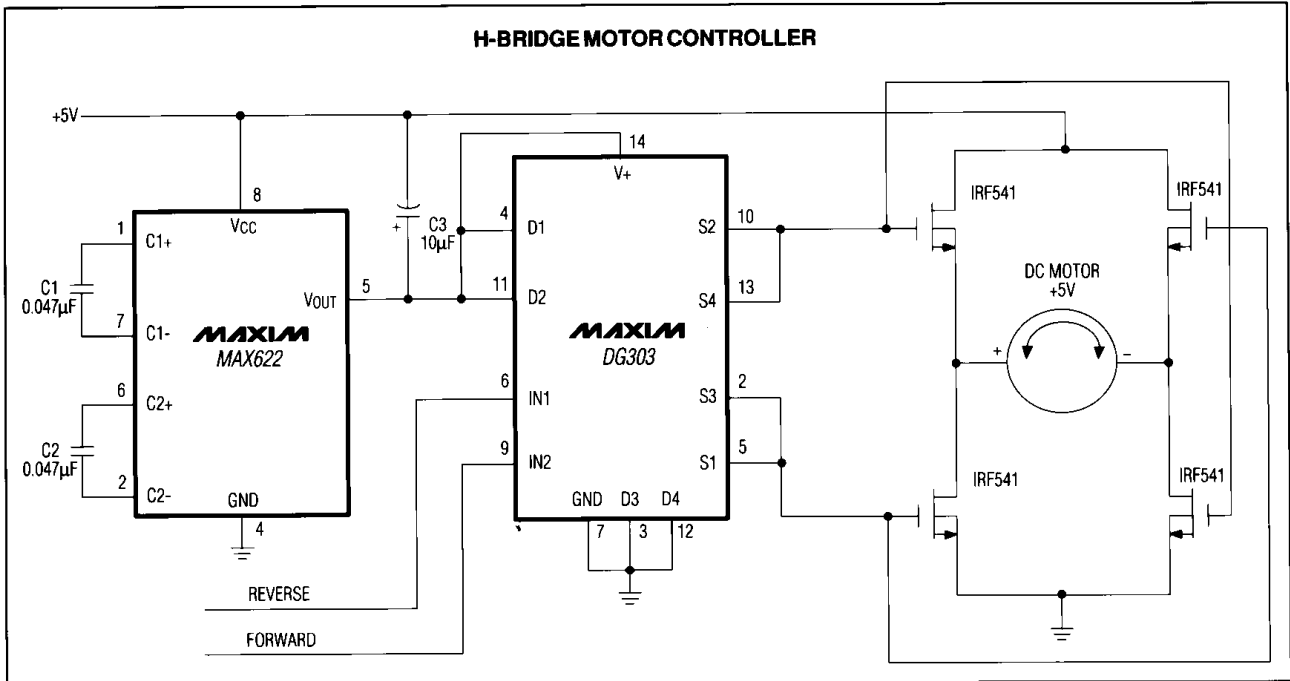

Figure 5. H-Bridge Motor Controller

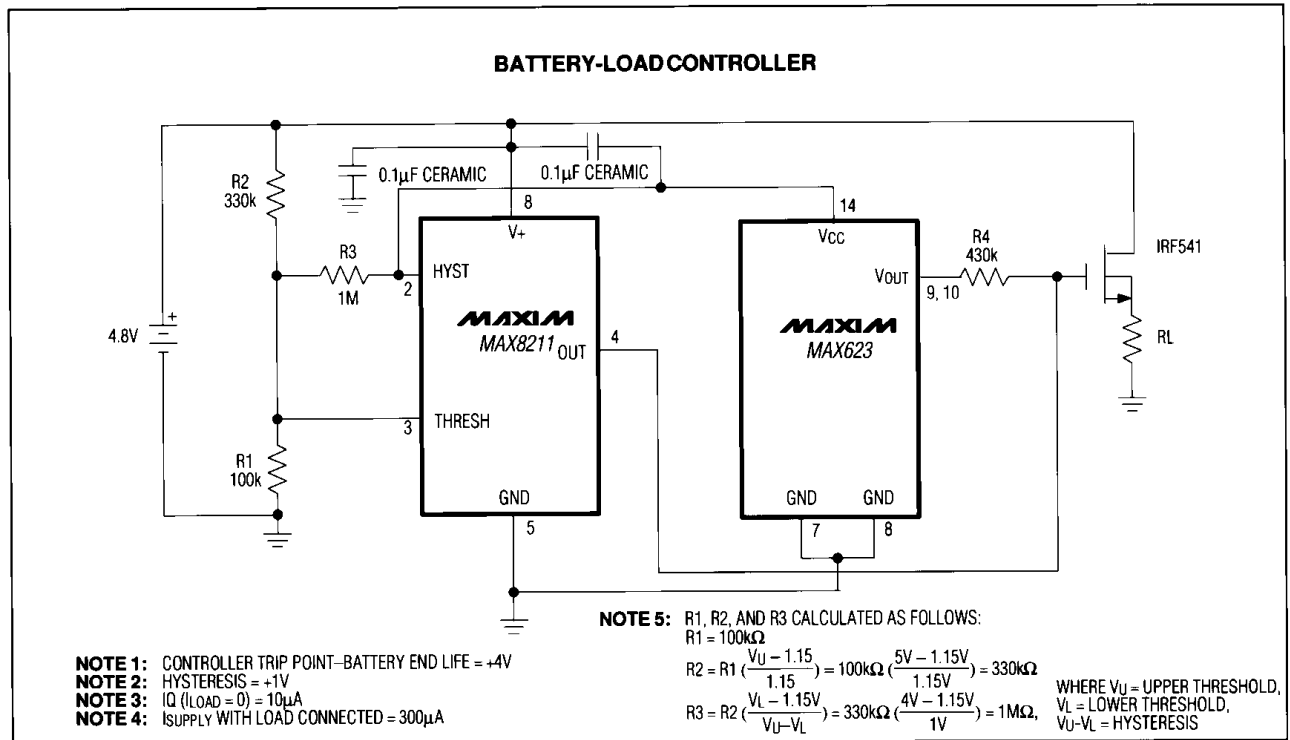

Figure 6. Battery-Load Controller Prevents Excessive Load at Battery End-of-Life

# High-Side Power Supplies

MAX622/MAX623

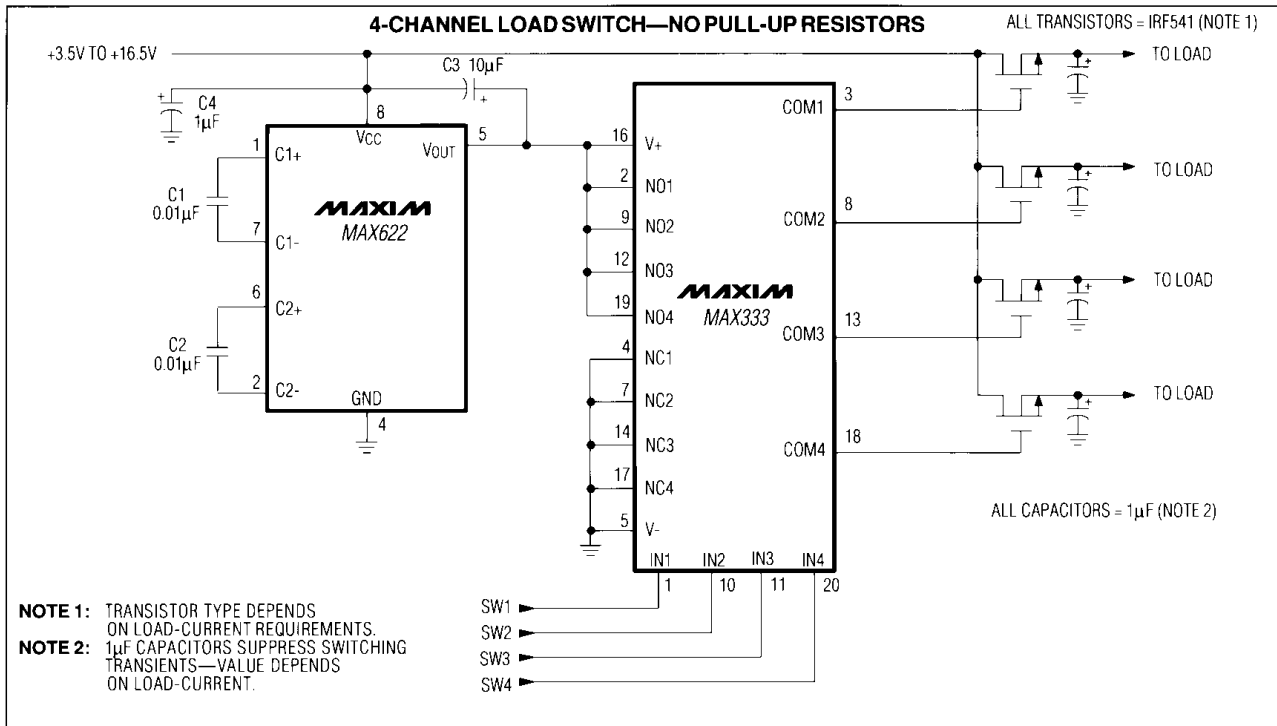

Figure 7. A MAX622 Powers a MAX333 Quad Analog Switch, Realizing a 4-Channel Load Switch with No Pull-Up Resistors

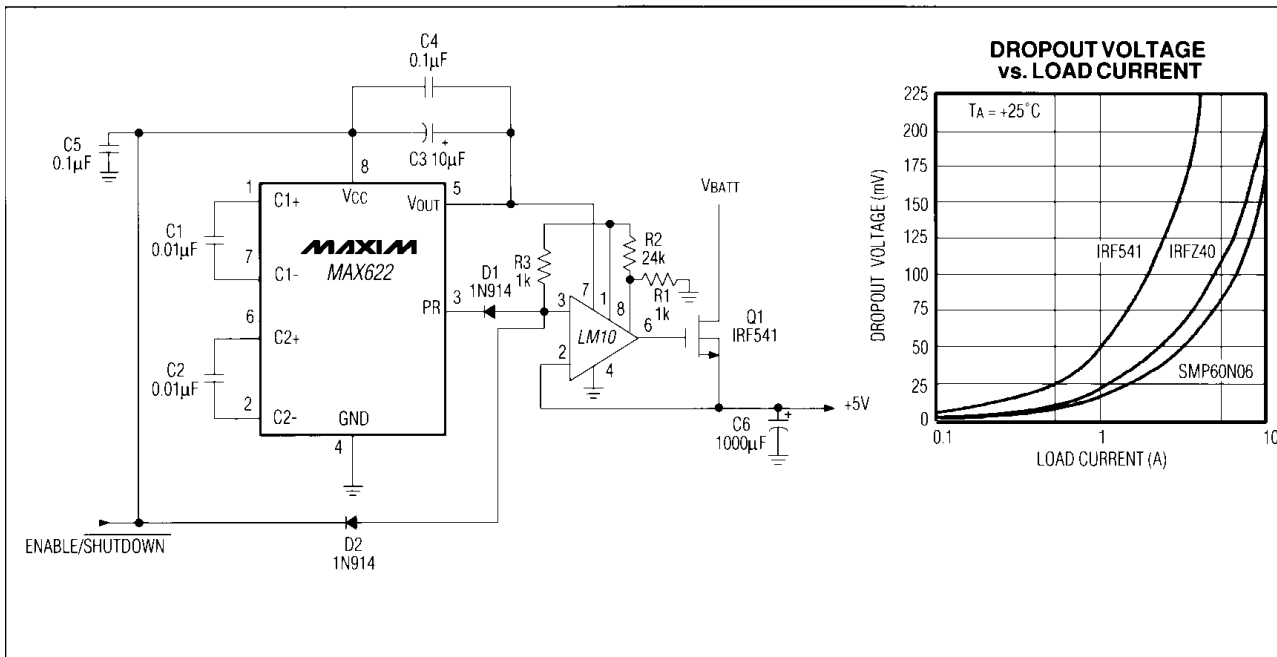
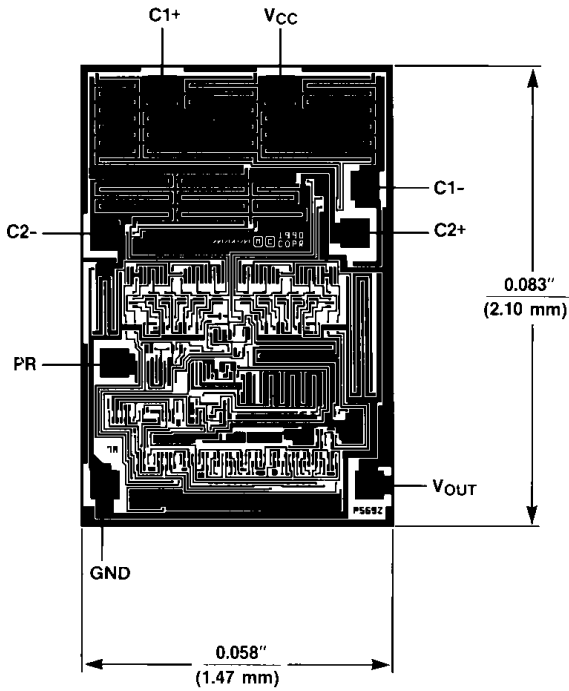

Figure 8. Ultra-Low Dropout Positive Voltage Regulator with Logic-Controlled Enable/Shutdown

# High-Side Power Supplies

## Chip Topography



**NOTE:** Connect substrate to V<sub>OUT</sub>.

MAX622/MAX623 Transistor Count: 158

Maxim cannot assume responsibility for use of any circuitry other than circuitry entirely embodied in a Maxim product. No circuit patent licenses are implied. Maxim reserves the right to change the circuitry and specifications without notice at any time.

12 **Maxim Integrated Products, 120 San Gabriel Drive, Sunnyvale, CA 94086 (408) 737-7600**

© 1991 Maxim Integrated Products

Printed USA

**MAXIM** is a registered trademark of Maxim Integrated Products.