



Precision Shunt Regulators with Reset in SOT23-3

MAX6330/MAX6331

General Description

The MAX6330/MAX6331 combine a precision shunt regulator with a power-on reset function in a single SOT23-3 package. They offer a low-cost method of operating small microprocessor (μ P)-based systems from high-voltage sources, while simultaneously protecting μ Ps from power-up, power-down, and brownout conditions.

Both active-low (MAX6330) and active-high (MAX6331) push/pull output versions are available. The output voltage has $\pm 1.5\%$ tolerance. The MAX6330/MAX6331 operate over a wide shunt current range from 100 μ A to 50mA, and offer very good transient immunity.

A 3-pin SOT23 package allows for a significant reduction in board space and improves reliability compared to multiple-IC/discrete solutions. These devices have a minimum order increment of 2,500 pieces.

Applications

- Controllers
- Household Appliances
- Intelligent Instruments
- Critical μ P and μ C Power Monitoring
- Portable/Size-Sensitive Equipment
- Automotive

Typical Operating Circuit

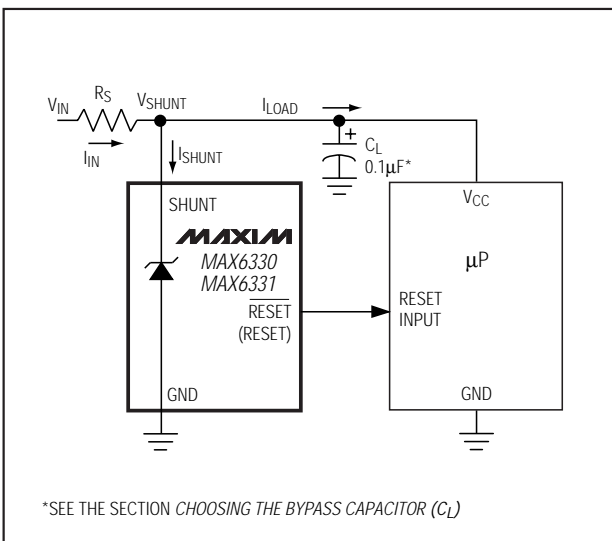

Features

- ◆ 100 μ A to 50mA Shunt Current Range
- ◆ Low Cost
- ◆ 3-Pin SOT23 Package
- ◆ $\pm 1.5\%$ Tolerance on Output Voltage
- ◆ Three Shunt Voltages Available: 5V, 3.3V, 3.0V
- ◆ Precision Power-On Reset Threshold:
 - 1.5% Tolerance Available with Either RESET (MAX6331) or $\overline{\text{RESET}}$ (MAX6330) Outputs
- ◆ 140ms Reset Timeout Period—No External Components Required

Ordering Information

PART*	TEMP. RANGE	PIN-PACKAGE
MAX6330_UR-T	-40°C to +85°C	3 SOT23-3
MAX6331_UR-T	-40°C to +85°C	3 SOT23-3

*Insert the desired suffix letter (from the table below) into the blank to complete the part number. These devices have a minimum order increment of 2,500 pieces.

SUFFIX	RESET THRESHOLD (V)	SHUNT REGULATOR VOLTAGE (V)	SOT TOP MARK	
			MAX6330	MAX6331
L	4.63	5.0	EKAA	ELAA
T	3.06	3.3	EMAA	ENAA
S	2.78	3.0	EDAA	EPAA

Pin Configuration

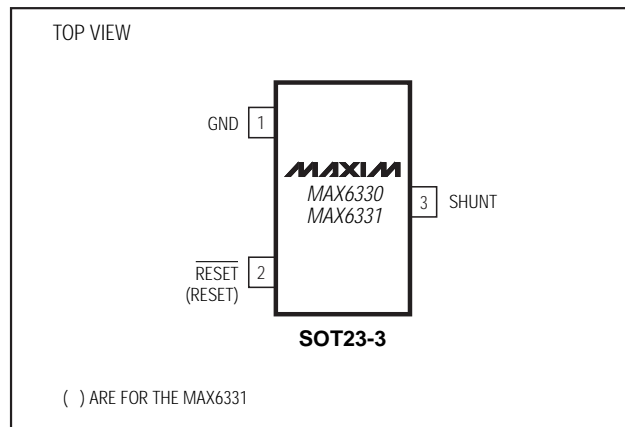

Precision Shunt Regulators with Reset in SOT23-3

ABSOLUTE MAXIMUM RATINGS

Terminal Voltage (with respect to GND),
All Pins Except SHUNT-0.3V to (V_{SHUNT} + 0.3V)
Input Current (I_{SHUNT})60mA
Output Current (RESET/RESET)20mA
Short-Circuit DurationContinuous

Continuous Power Dissipation
SOT23-3 (derate 4mW/°C above +70°C)320mW
Operating Temperature Range-40°C to +85°C
Storage Temperature Range-65°C to +160°C
Lead Temperature (soldering, 10sec)+300°C

Stresses beyond those listed under "Absolute Maximum Ratings" may cause permanent damage to the device. These are stress ratings only, and functional operation of the device at these or any other conditions beyond those indicated in the operational sections of the specifications is not implied. Exposure to absolute maximum rating conditions for extended periods may affect device reliability.

ELECTRICAL CHARACTERISTICS

(I_{SHUNT} = 1mA, C_L = 0.1µF, T_A = -40°C to +85°C, unless otherwise noted. Typical values are at T_A = +25°C.)

PARAMETER	SYMBOL	CONDITIONS		MIN	TYP	MAX	UNITS	
V _{SHUNT} Regulation Voltage (Note 1)	V _{SHUNT}	I _{SHUNT} = 0.1mA to 50mA	MAX633_L	T _A = +25°C	4.93	5.0	5.07	V
				T _A = -40°C to +85°C	4.85		5.15	
			MAX633_T	T _A = +25°C	3.25	3.3	3.35	
				T _A = -40°C to +85°C	3.20		3.40	
			MAX633_S	T _A = +25°C	2.96	3.0	3.04	
				T _A = -40°C to +85°C	2.91		3.09	
Minimum V _{SHUNT} for which RESET is Valid (MAX6330)			T _A = 0°C to +70°C	1.0			V	
			T _A = -40°C to +85°C	1.2				
V _{SHUNT} Tempco					40		ppm/°C	
Minimum Shunt Current (Note 2)	I _{SHUNT(min)}			100	60		µA	
Maximum Shunt Current (Note 3)	I _{SHUNT(max)}					50	mA	
Reset Threshold Voltage	V _{TH}	MAX633_L	T _A = +25°C	4.56	4.63	4.69	V	
			T _A = -40°C to +85°C	4.50		4.75		
		MAX633_T	T _A = +25°C	3.01	3.06	3.11		
			T _A = -40°C to +85°C	2.97		3.15		
		MAX633_S	T _A = +25°C	2.74	2.78	2.82		
			T _A = -40°C to +85°C	2.70		2.86		
Reset Threshold Tempco					40		ppm/°C	
V _{SHUNT} to Reset Delay			100mV overdrive, C _L = 15pF		20		µs	
Reset Pulse Width				100	140	200	ms	

Precision Shunt Regulators with Reset in SOT23-3

MAX6330/MAX6331

ELECTRICAL CHARACTERISTICS (continued)

($I_{SHUNT} = 1\text{mA}$, $C_L = 0.1\mu\text{F}$, $T_A = -40^\circ\text{C}$ to $+85^\circ\text{C}$, unless otherwise noted. Typical values are at $T_A = +25^\circ\text{C}$.)

PARAMETER	SYMBOL	CONDITIONS	MIN	TYP	MAX	UNITS	
RESET/ $\overline{\text{RESET}}$ Output Voltage Low (Note 4)	V_{OL}	$I_{SINK} = 3.2\text{mA}$	MAX6330L, $V_{TH(\text{min})}$			0.4	V
			MAX6331L, $V_{TH(\text{max})}$				
		$I_{SINK} = 1.2\text{mA}$	MAX6330T/S, $V_{TH(\text{min})}$			0.3	
			MAX6331T/S, $V_{TH(\text{max})}$				
		MAX6330, $V_{SHUNT} = 1\text{V}$, $I_{SINK} = 50\mu\text{A}$, $T_A = 0^\circ\text{C}$ to $+70^\circ\text{C}$			0.3		
MAX6330, $V_{SHUNT} = 1.2\text{V}$, $I_{SINK} = 50\mu\text{A}$, $T_A = -40^\circ\text{C}$ to $+85^\circ\text{C}$			0.3				
RESET/ $\overline{\text{RESET}}$ Output Voltage High (Note 4)	V_{OH}	$I_{SOURCE} = 800\mu\text{A}$	MAX6331L, $V_{TH(\text{min})}$	0.8 x V_{SHUNT}		V	
			MAX6330L, $V_{TH(\text{max})}$				
		$I_{SOURCE} = 500\mu\text{A}$	MAX6331T/S, $V_{TH(\text{min})}$	0.8 x V_{SHUNT}			
			MAX6330T/S, $V_{TH(\text{max})}$				
MAX6331, $1.8\text{V} < V_{SHUNT} < V_{TH(\text{min})}$, $I_{SOURCE} = 150\mu\text{A}$		0.8 x V_{SHUNT}					

Note 1: It is recommended that the regulation voltage be measured using a 4-wire force-sense technique when operating at high shunt currents. For operating at elevated temperatures, the device must be derated based on a $+150^\circ\text{C}$ maximum allowed junction temperature and a maximum thermal resistance of $0.25^\circ\text{C}/\text{mW}$ junction to ambient when soldered on a printed circuit board. The $T_A = +25^\circ\text{C}$ specification over load is measured using a pulse test at 50mA with less than 5ms on time.

Note 2: Minimum shunt current required for regulated V_{SHUNT} .

Note 3: Maximum shunt current required for regulated V_{SHUNT} .

Note 4: In a typical application where SHUNT serves as the system voltage regulator, note that both I_{SOURCE} for V_{OH} and I_{SINK} for V_{OL} come from V_{SHUNT} (see the *Typical Operating Circuit*).

Precision Shunt Regulators with Reset in SOT23-3

Typical Operating Characteristics

(Typical Operating Circuit, $C_L = 0.1\mu\text{F}$, $I_{\text{LOAD}} = 0\text{mA}$, $T_A = +25^\circ\text{C}$, unless otherwise noted.)

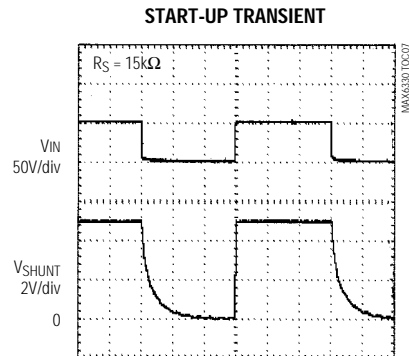
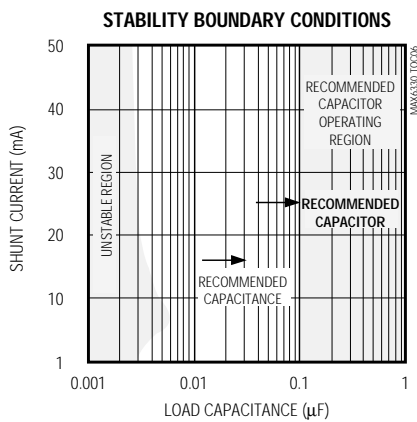
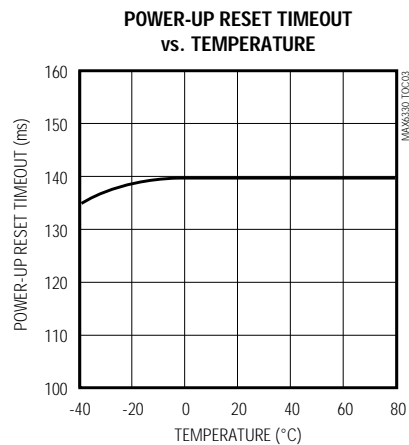
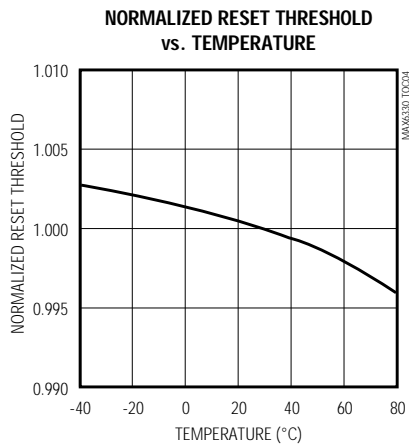
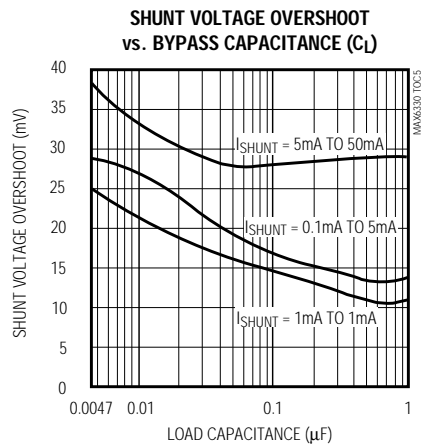
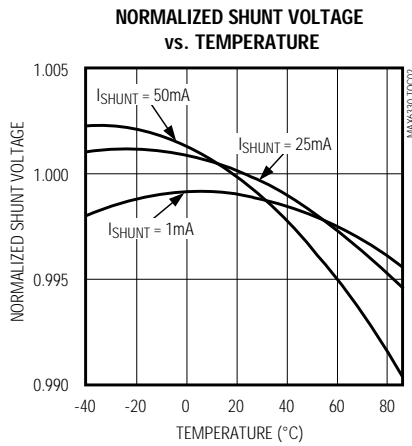
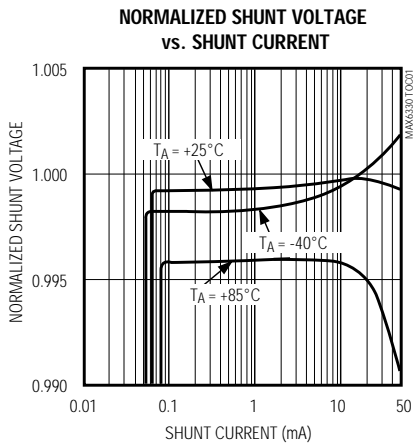

Precision Shunt Regulators with Reset in SOT23-3

Pin Description

MAX6330/MAX6331

PIN		NAME	FUNCTION
MAX6330	MAX6331		
1	1	GND	Ground
2	—	$\overline{\text{RESET}}$	Inverting Reset Output. $\overline{\text{RESET}}$ remains low while V_{SHUNT} is below the reset threshold and for 140ms after V_{SHUNT} rises above the threshold.
—	2	RESET	Noninverting Reset Output. RESET remains high while V_{SHUNT} is below the reset threshold and for 140ms after V_{SHUNT} rises above the threshold.
3	3	SHUNT	Regulated Shunt Voltage (+5V, +3.3V, or +3.0V)

Detailed Description

Reset Output

A microprocessor's (μP 's) reset input starts the μP in a known state. The MAX6330/MAX6331 μP supervisory circuits assert reset to prevent code-execution errors during power-up, power-down, or brownout conditions.

$\overline{\text{RESET}}$ is guaranteed to be a logic low for $V_{\text{SHUNT}} > 1\text{V}$. Once V_{SHUNT} exceeds the reset threshold, an internal timer keeps $\overline{\text{RESET}}$ low for the reset timeout period; after this interval, $\overline{\text{RESET}}$ goes high.

If a brownout condition occurs (V_{SHUNT} dips below the reset threshold), $\overline{\text{RESET}}$ goes low. When V_{SHUNT} falls below the reset threshold, the internal timer resets to zero and $\overline{\text{RESET}}$ goes low. The internal timer starts after V_{SHUNT} returns above the reset threshold, and $\overline{\text{RESET}}$ then remains low for the reset timeout period.

The MAX6331 has an active-high RESET output that is the inverse of the MAX6330's $\overline{\text{RESET}}$ output.

Shunt Regulator

The shunt regulator consists of a pass device and a controlling circuit, as illustrated in Figure 1. The pass device allows the regulator to sink current while regulating the desired output voltage within a $\pm 1.5\%$ tolerance. The shunt current range (I_{SHUNT}) is $100\mu\text{A}$ to 50mA .

The pass transistor in the MAX6330/MAX6331 maintains a constant output voltage (V_{SHUNT}) by sinking the necessary amount of shunt current. When I_{LOAD} (see *Typical Operating Circuit*) is at a maximum, the shunt current is at a minimum, and vice versa:

$$I_{\text{IN}} = I_{\text{SHUNT}} + I_{\text{LOAD}} = (V_{\text{IN}} - V_{\text{SHUNT}}) / R_{\text{S}}$$

Consider the following information when choosing the external resistor R_{S} :

- 1) The input voltage range, (V_{IN})
- 2) The regulated voltage, (V_{SHUNT})
- 3) The output current range, (I_{LOAD})

Choose R_{S} as follows:

$$(V_{\text{IN}(\text{max})} - V_{\text{SHUNT}(\text{min})}) / (50\text{mA} + I_{\text{LOAD}(\text{min})}) \leq R_{\text{S}} \leq (V_{\text{IN}(\text{min})} - V_{\text{SHUNT}(\text{max})}) / (100\mu\text{A} + I_{\text{LOAD}(\text{max})})$$

Choose the largest nominal resistor value for R_{S} that gives the lowest current consumption. Provide a safety margin to incorporate the worst-case tolerance of the

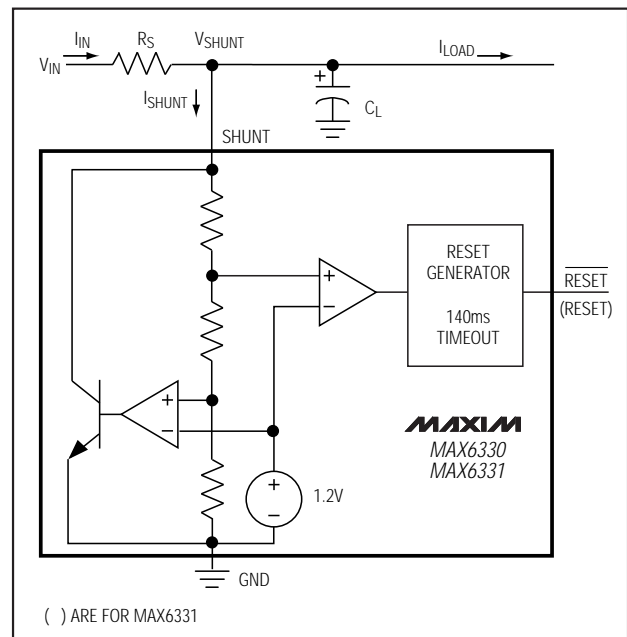

Figure 1. Functional Diagram

Precision Shunt Regulators with Reset in SOT23-3

resistor used. Ensure that the resistor's power rating is adequate, using the following general power equation:

$$\begin{aligned}
 P_R &= I_{IN}(V_{IN(max)} - V_{SHUNT}) \\
 &= I_{IN}^2 R_S \\
 &= (V_{IN(max)} - V_{SHUNT})^2 / R_S
 \end{aligned}$$

Applications Information

Negative-Going V_{SHUNT} Transients

In addition to issuing a reset to the μP during power-up, power-down, and brownout conditions, the MAX6330/MAX6331 are relatively immune to short-duration negative-going V_{SHUNT} transients (glitches). Additional bypass filter capacitance mounted close to the SHUNT pin provides additional transient immunity.

Choosing the Bypass Capacitor, C_L

The bypass capacitor (C_L) on the SHUNT pin can significantly affect the device's load-transient response, so choose it carefully. When a load transient occurs, the current for this load is diverted from the shunt regulator.

The maximum load current that can be diverted from the regulator is:

$$\begin{aligned}
 I_{LOAD} \text{ (diverted from regulator)} &= I_{SHUNT(max)} - I_{SHUNT(min)} \\
 &= 50\text{mA} - 100\mu\text{A} \\
 &= 49.9\text{mA}
 \end{aligned}$$

The shunt regulator has a finite response to this transient. The instantaneous requirements of the load change are met by the charge on C_L , resulting in overshoot/undershoot on V_{SHUNT} . The magnitude of this overshoot/undershoot increases with I_{SHUNT} and decreases with C_L . When V_{SHUNT} undershoots, the shunt current decreases to where it will only draw quiescent current (I_Q), and the shunt element turns off. At this point, V_{SHUNT} will slew toward V_{IN} at the following rate:

$$\Delta V_{SHUNT} / \Delta t = (I_{IN} - I_{LOAD} - 60\mu\text{A}) / C_L$$

As V_{SHUNT} rises, it will turn on the shunt regulator when it can sink $100\mu\text{A}$ of current. A finite response time for the shunt regulator to start up will result in a brief overshoot of V_{SHUNT} before it settles into its regulation voltage. Therefore, I_{LOAD} should always be $100\mu\text{A}$ or more below I_{IN} , or V_{SHUNT} will not recover to its regulation point. To prevent this condition, be sure to select the correct series-resistor R_S value (see the *Shunt Regulator* section).

Figures 2, 3, and 4 show load-transient responses for different choices of bypass capacitors on V_{SHUNT} . These photos clearly illustrate the benefits and drawbacks of the capacitor options. A smaller bypass

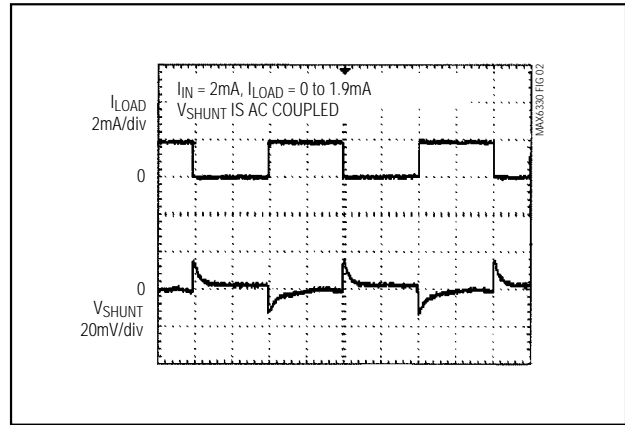

Figure 2. Load-Transient Response with $C_L = 0.22\mu\text{F}$

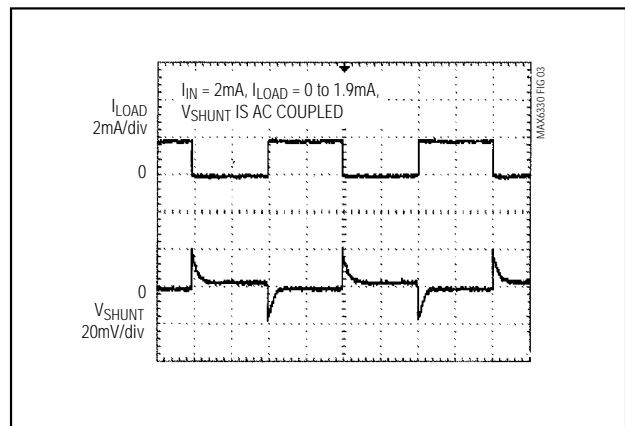

Figure 3. Load-Transient Response with $C_L = 0.033\mu\text{F}$

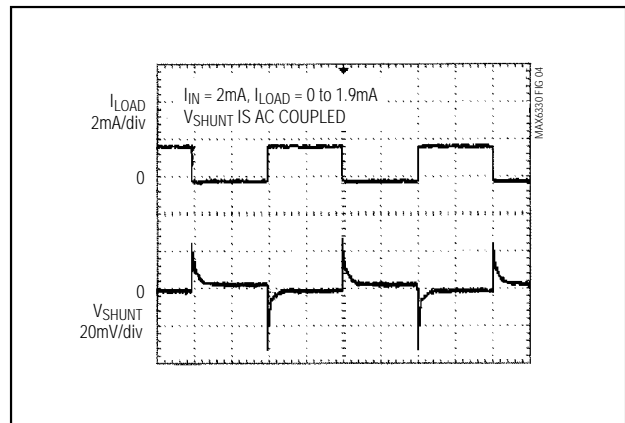

Figure 4. Load-Transient Response with $C_L = 0.0047\mu\text{F}$

Precision Shunt Regulators with Reset in SOT23-3

capacitor allows a sharper drop in V_{SHUNT} when the load transient occurs, and will suffer from a steeper overshoot when the device re-enters regulation. On the other hand, the increased compensation on a larger bypass capacitor will lead to a longer recovery time to regulation. The *Typical Operating Characteristics* graph Overshoot vs. Bypass Capacitance (C_L) illustrates this trade-off.

If the compensation of the bypass capacitor chosen is insufficient, the output (V_{SHUNT}) can oscillate. Before choosing a bypass capacitor for the desired shunt current, observe the stability boundary conditions indicated in the *Typical Operating Characteristics*. The minimum output capacitance is $0.03\mu\text{F}$ to ensure stability over the full load-current range.

Adding Hysteresis

In certain circumstances, the MAX6330 can be trapped in a state that forces it to enter into and exit from a reset condition indefinitely. This usually occurs in systems where V_{SHUNT} is just below the device's trip threshold and the system draws less quiescent current under reset conditions than when operating out of reset. The difference in supply current when the device is in or out of reset can translate to a significant change in the voltage drop across R_S , which the MAX6330's built-in hysteresis may not overcome. A $100\text{k}\Omega$ pull-up resistor will overcome this condition and add hysteresis (Figure 5).

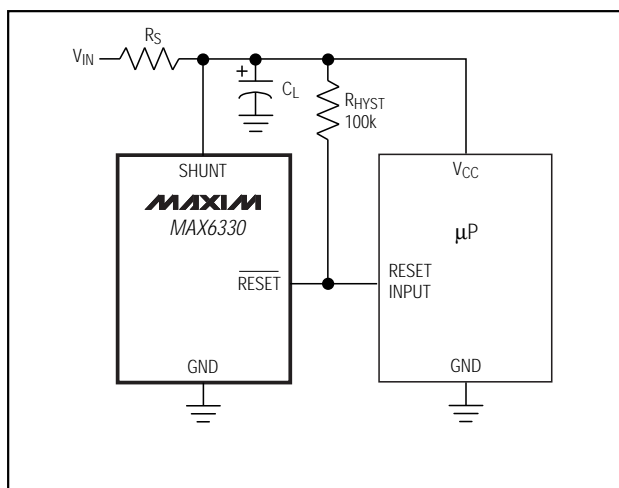

Figure 5. Adding Hysteresis to the MAX6330

Note that adding this pull-up resistor to the MAX6330 will render $\overline{\text{RESET}}$ invalid with $V_{SHUNT} < 1\text{V}$, since this output loses sinking capability at this point, and the pull-up resistor would invalidate the signal. This does not present a problem in most applications, since most μPs and other circuitry are inoperative when V_{SHUNT} is below 1V .

Interfacing to μPs with Bidirectional Reset Pins

Microprocessors with bidirectional reset pins (such as the Motorola 68HC11 series) can contend with MAX6330's reset output. If, for example, the MAX6330's $\overline{\text{RESET}}$ output is asserted high and the μP wants to pull it low, indeterminate logic levels may result. To correct this, connect a $4.7\text{k}\Omega$ resistor between the $\overline{\text{RESET}}$ output and the μP reset I/O (Figure 6). Buffer the $\overline{\text{RESET}}$ output to other system components. Also, R_S must be sized to compensate for additional current drawn by the μP during the fault condition.

Shunt Current Effects on V_{SHUNT} and V_{TH}

When sinking large shunt currents, power dissipation heats the die to temperatures greater than ambient. This may cause the V_{SHUNT} and V_{TH} tolerances to approach $\pm 3\%$ at high ambient temperatures and high shunt currents. Limit the die temperature to less than $+150^\circ\text{C}$ using $\theta_{JA} = 0.25^\circ\text{C}/\text{mW}$.

Chip Information

TRANSISTOR COUNT: 283

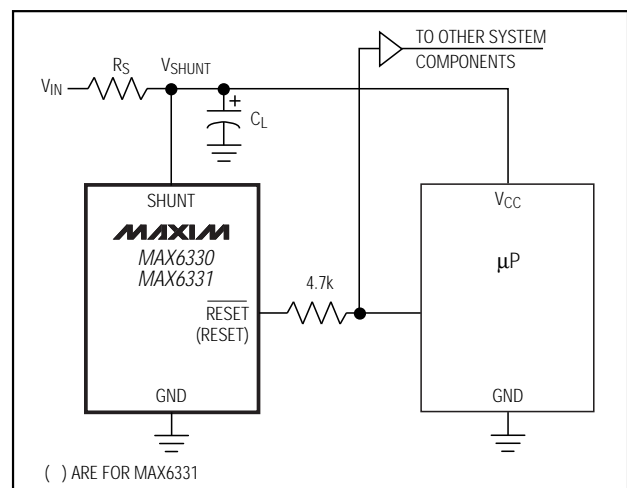

Figure 6. Interfacing to μPs with Bidirectional Reset I/O

Precision Shunt Regulators with Reset in SOT23-3

Package Information

NOTES:

1. D&E DO NOT INCLUDE MOLD FLASH.
2. MOLD FLASH OR PROTRUSIONS NOT TO EXCEED .15mm (.006")
3. CONTROLLING DIMENSION: MILLIMETER

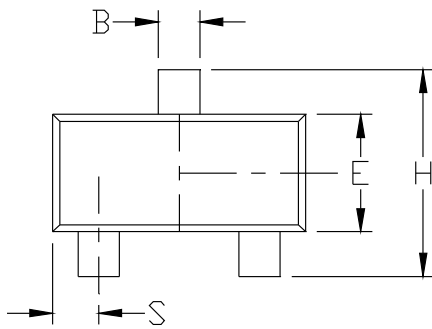

DIM	INCHES		MILLIMETERS	
	MIN	MAX	MIN	MAX
A	0.031	0.047	0.787	1.194
A1	0.001	0.005	0.025	0.127
B	0.014	0.022	0.356	0.559
C	0.0034	0.006	0.086	0.152
D	0.105	0.120	2.667	3.048
E	0.047	0.055	1.194	1.397
e	0.070	0.080	1.778	2.032
H	0.082	0.098	2.083	2.489
L	0.004	0.012	0.102	0.305
S	0.017	0.022	0.432	0.559
α	0°	8°	0°	8°

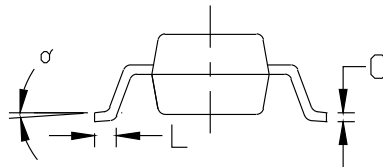
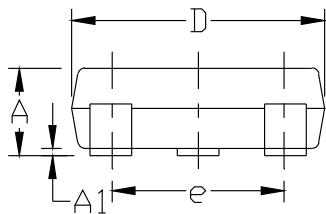

MAXIM			
<small>PROPRIETARY INFORMATION</small>			
<small>TITLE:</small>			
PACKAGE OUTLINE, SOT-23, 3L			
<small>APPROVAL</small>	<small>DOCUMENT CONTROL NO.</small>	<small>REV</small>	<small>1/1</small>
	21-0051	C	

SOT23-3LEFS

Maxim cannot assume responsibility for use of any circuitry other than circuitry entirely embodied in a Maxim product. No circuit patent licenses are implied. Maxim reserves the right to change the circuitry and specifications without notice at any time.

8 Maxim Integrated Products, 120 San Gabriel Drive, Sunnyvale, CA 94086 408-737-7600

© 1998 Maxim Integrated Products

Printed USA

MAXIM is a registered trademark of Maxim Integrated Products.