



Full-Featured μ P Supervisory Circuit with $\pm 1.5\%$ Reset Accuracy

General Description

The MAX807 microprocessor (μ P) supervisory circuit reduces the complexity and number of components needed to monitor power-supply and battery-control functions in μ P systems. A $70\mu\text{A}$ supply current makes the MAX807 ideal for use in portable equipment, while a 2ns chip-enable propagation delay and 250mA output current capability (20mA in battery-backup mode) make it suitable for larger, higher-performance equipment.

The MAX807 comes in 16-pin DIP and SO packages, and provides the following functions:

- 1) μ P reset. The active-low RESET output is asserted during power-up, power-down, and brownout conditions, and is guaranteed to be in the correct state for V_{CC} down to 1V.
- 2) Active-high RESET output.
- 3) Manual-reset input.
- 4) Two-stage power-fail warning. A separate low-line comparator compares V_{CC} to a threshold 52mV above the reset threshold. This low-line comparator is more accurate than those in previous μ P supervisors.
- 5) Backup-battery switchover for CMOS RAM, real-time clocks, μ Ps, or other low-power logic.
- 6) Write protection of CMOS RAM or EEPROM.
- 7) 2.275V threshold detector—provides for power-fail warning and low-battery detection, or monitors a power supply other than +5V.
- 8) BATT OK status flag indicates that the backup-battery voltage is above 2.275V.
- 9) Watchdog-fault output—asserted if the watchdog input has not been toggled within a preset timeout period.

Applications

Computers
 Controllers
 Intelligent Instruments
 Critical μ P Power Monitoring
 Portable/Battery-Powered Equipment

Features

- ◆ Precision 4.675V (MAX807L) or 4.425V (MAX807M), or 4.575V (MAX807N) Voltage Monitoring
- ◆ 200ms Power OK / Reset Time Delay
- ◆ RESET and RESET Outputs
- ◆ Independent Watchdog Timer
- ◆ 1 μ A Standby Current
- ◆ Power Switching:
 250mA in V_{CC} Mode
 20mA in Battery-Backup Mode
- ◆ On-Board Gating of Chip-Enable Signals:
 2ns CE Gate Propagation Delay
- ◆ MaxCap™ and SuperCap™ Compatible
- ◆ Voltage Monitor for Power-Fail
- ◆ Backup-Battery Monitor
- ◆ Guaranteed RESET Valid to $V_{CC} = 1\text{V}$
- ◆ $\pm 1.5\%$ Low-line Threshold Accuracy 52mV above Reset Threshold

MAX807L/M/N

Pin Configuration

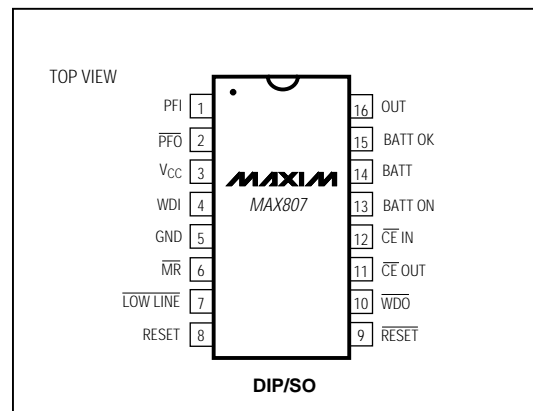

Ordering Information and Typical Operating Circuit appear at end of data sheet.

SuperCap is a trademark of Baknor Industries. MaxCap is a trademark of The Carborundum Corp.



Maxim Integrated Products 1

Call toll free 1-800-998-8800 for free samples or literature.

Full-Featured μ P Supervisory Circuit with $\pm 1.5\%$ Reset Accuracy

MAX807L/M/N

ABSOLUTE MAXIMUM RATINGS

Input Voltages (with respect to GND)

| | |
|-------------------------|------------------------------------|
| V _{CC} | -0.3V to 6V |
| V _{BATT} | -0.3V to 6V |
| All Other Inputs | -0.3V to (V _{OUT} + 0.3V) |

Input Current

| | |
|------------------------------------|-------|
| V _{CC} Peak | 1.0A |
| V _{CC} Continuous | 500mA |
| I _{BATT} Peak | 250mA |
| I _{BATT} Continuous | 50mA |
| GND | 50mA |
| All Other Inputs | 50mA |

Continuous Power Dissipation (T_A = +70°C)

| | |
|---|-------|
| Plastic DIP (derate 10.53mW/°C above +70°C) | 842mW |
| Wide SO (derate 9.52mW/°C above +70°C) | 762mW |
| CERDIP (derate 10.00mW/°C above +70°C) | 800mW |

Operating Temperature Ranges

| | |
|---|-----------------|
| MAX807_C_E | 0°C to +70°C |
| MAX807_E_E | -40°C to +85°C |
| MAX807_MJE | -55°C to +125°C |
| Storage Temperature Range | -65°C to +160°C |
| Lead Temperature (soldering, 10sec) | +300°C |

Stresses beyond those listed under "Absolute Maximum Ratings" may cause permanent damage to the device. These are stress ratings only, and functional operation of the device at these or any other conditions beyond those indicated in the operational sections of the specifications is not implied. Exposure to absolute maximum rating conditions for extended periods may affect device reliability.

ELECTRICAL CHARACTERISTICS

(V_{CC} = 4.60V to 5.5V for the MAX807L, V_{CC} = 4.50V to 5.5V for the MAX807N, V_{CC} = 4.35V to 5.5V for the MAX807M, V_{BATT} = 2.8V, V_{PFI} = 0V, T_A = T_{MIN} to T_{MAX}. Typical values are tested with V_{CC} = 5V and T_A = +25°C, unless otherwise noted.)

| PARAMETER | SYMBOL | CONDITIONS | MIN | TYP | MAX | UNITS |
|---|--|---|--------------------------|--------------------------|-----|-------|
| Operating Voltage Range V _{BATT} , V _{CC} (Note 1) | | | 0 | | 5.5 | V |
| V _{OUT} in Normal Operating Mode | V _{CC} = 4.5V | I _{OUT} = 25mA | V _{CC} - 0.02 | | | V |
| | | I _{OUT} = 250mA, MAX807C/E | V _{CC} - 0.35 | V _{CC} - 0.22 | | |
| | | I _{OUT} = 250mA, MAX807M | V _{CC} - 0.45 | | | |
| | | V _{CC} = 3V, V _{BATT} = 2.8V, I _{OUT} = 100mA | V _{CC} - 0.25 | V _{CC} - 0.12 | | |
| V _{CC} to OUT On-Resistance | | V _{CC} = 4.5V, I _{OUT} = 250mA | MAX807C/E | 1.0 | 1.4 | Ω |
| | | | MAX807M | | 1.8 | |
| | | V _{CC} = 3V, I _{OUT} = 100mA | | 1.2 | 2.5 | |
| V _{OUT} in Battery-Backup Mode | | V _{BATT} = 4.5V, I _{OUT} = 20mA, V _{CC} = 0V | V _{BATT} - 0.17 | | | V |
| | | V _{BATT} = 2.8V, I _{OUT} = 10mA, V _{CC} = 0V | V _{BATT} - 0.25 | V _{BATT} - 0.12 | | |
| | | V _{BATT} = 2.0V, I _{OUT} = 5mA, V _{CC} = 0V | V _{BATT} - 0.20 | V _{BATT} - 0.08 | | |
| BATT to OUT On-Resistance | | V _{BATT} = 4.5V, I _{OUT} = 20mA | 8.5 | | | Ω |
| | | V _{BATT} = 2.8V, I _{OUT} = 10mA | 12 | 25 | | |
| | | V _{BATT} = 2.0V, I _{OUT} = 5mA | 16 | 40 | | |
| Supply Current in Normal Operating Mode (excludes I _{OUT}) | | | | 70 | 110 | μA |
| Supply Current in Battery-Backup Mode (excludes I _{OUT}) (Note 2) | V _{CC} = 0V, V _{BATT} = 2.8V | T _A = +25°C | | 0.4 | 1 | μA |
| | | MAX807C/E | | | 5 | |
| | | MAX807M | | | 50 | |
| BATT Standby Current (Note 3) | V _{BATT} + 0.2V ≤ V _{CC} | T _A = +25°C | -0.1 | | 0.1 | μA |
| | | T _A = T _{MIN} to T _{MAX} | -1.0 | | 1.0 | |
| Battery-Switchover Threshold | V _{BATT} = 2.8V | Power up | V _{BATT} + 0.05 | | | V |
| | | Power down | V _{BATT} | | | |
| Battery-Switchover Hysteresis | | | | 50 | | mV |
| BATT ON Output, Low Voltage | | V _{RST} (max), I _{SINK} = 3.2mA | | 0.1 | 0.4 | V |
| BATT ON Output, High Voltage | | V _{CC} = 0V, I _{SOURCE} = 0.1mA, V _{BATT} = 2.8V | 2 | 2.7 | | V |

Full-Featured μ P Supervisory Circuit with $\pm 1.5\%$ Reset Accuracy

MAX807L/M/N

ELECTRICAL CHARACTERISTICS (continued)

($V_{CC} = 4.60V$ to $5.5V$ for the MAX807L, $V_{CC} = 4.50V$ to $5.5V$ for the MAX807N, $V_{CC} = 4.35V$ to $5.5V$ for the MAX807M, $V_{BATT} = 2.8V$, $V_{PFI} = 0V$, $T_A = T_{MIN}$ to T_{MAX} . Typical values are tested with $V_{CC} = 5V$ and $T_A = +25^\circ C$, unless otherwise noted.)

| PARAMETER | SYMBOL | CONDITIONS | MIN | TYP | MAX | UNITS | |
|--|-----------|---|------------------------------|----------------|-------|---------|---|
| BATT ON Output Short-Circuit Current | | Sink current | | 70 | | mA | |
| | | Source current, $V_{CC} = 0V$, $V_{BATT} = 2.8V$ | | 5 | | | |
| RESET, LOW LINE, AND WATCHDOG TIMER | | | | | | | |
| Reset Threshold | V_{RST} | V_{CC} rising and falling | MAX807L | 4.600 | 4.675 | 4.750 | V |
| | | | MAX807N | 4.500 | 4.575 | 4.650 | |
| | | | MAX807M | 4.350 | 4.425 | 4.500 | |
| Reset Threshold Hysteresis | | | | 13 | | mV | |
| LOW LINE to RESET Threshold Voltage | V_{LR} | V_{CC} falling | 30 | 52 | 70 | mV | |
| LOW LINE Threshold, V_{CC} Rising | V_{LL} | MAX807L | | 4.73 | 4.81 | V | |
| | | MAX807N | | 4.63 | 4.71 | | |
| | | MAX807M | | 4.48 | 4.56 | | |
| V_{CC} to RESET Delay | | V_{CC} falling at $1mV/\mu s$ | | 26 | | μs | |
| V_{CC} to LOW LINE Delay | | V_{CC} falling at $1mV/\mu s$ | | 24 | | μs | |
| RESET Active Timeout Period | t_{RP} | V_{CC} rising | 140 | 200 | 280 | ms | |
| Watchdog Timeout Period | t_{WD} | | 1.12 | 1.6 | 2.24 | sec | |
| Minimum Watchdog Input Pulse Width | | $V_{IL} = 0.8V$, $V_{IH} = 0.75 \times V_{CC}$ | 100 | | | ns | |
| RESET Output Voltage | | $I_{SINK} = 50\mu A$, $V_{BATT} = 0V$, V_{CC} falling | $V_{CC} = 1V$, MAX807_C | | 0.3 | V | |
| | | | $V_{CC} = 1.2V$, MAX807_E/M | | 0.3 | | |
| | | $I_{SINK} = 3.2mA$, $V_{CC} = 4.25V$ | | 0.1 | 0.4 | | |
| | | $I_{SOURCE} = 0.1mA$ | $V_{CC} - 1.5$ | $V_{CC} - 0.1$ | | | |
| RESET Output Short-Circuit Current | I_{SC} | Output sink current, $V_{CC} = 4.25V$ | | 60 | | mA | |
| | | Output source current | | 1.6 | | | |
| RESET Output Voltage | | $I_{SINK} = 3.2mA$ | | | 0.4 | V | |
| | | $I_{SOURCE} = 5mA$ | $V_{CC} - 1.5$ | | | | |
| RESET Output Short-Circuit Current | I_{SC} | Output sink current | | 60 | | mA | |
| | | Output source current, $V_{CC} = 4.25V$ | | 15 | | | |
| LOW LINE Output Voltage | | $I_{SINK} = 3.2mA$, $V_{CC} = 4.25V$ | | | 0.4 | V | |
| | | $I_{SOURCE} = 5mA$ | $V_{CC} - 1.5$ | | | | |
| LOW LINE Output Short-Circuit Current | I_{SC} | Output sink current, $V_{CC} = 4.25V$ | | 28 | | mA | |
| | | Output source current | | 20 | | | |
| WDO Output Voltage | | $I_{SINK} = 3.2mA$ | | | 0.4 | V | |
| | | $I_{SOURCE} = 5mA$ | $V_{CC} - 1.5$ | | | | |
| WDO Output Short-Circuit Current | I_{SC} | Output sink current | | 35 | | mA | |
| | | Output source current | | 20 | | | |
| WDI Threshold Voltage (Note 4) | V_{IH} | | $0.75 \times V_{CC}$ | | | V | |
| | V_{IL} | | | | 0.8 | | |
| WDI Input Current | | Reset deasserted, $WDI = 0V$ | -50 | -10 | | μA | |
| | | Reset deasserted, $WDI = V_{CC}$ | | 16 | 50 | | |

Full-Featured μ P Supervisory Circuit with $\pm 1.5\%$ Reset Accuracy

MAX807L/M/N

ELECTRICAL CHARACTERISTICS (continued)

($V_{CC} = 4.60V$ to $5.5V$ for the MAX807L, $V_{CC} = 4.50V$ to $5.5V$ for the MAX807N, $V_{CC} = 4.35V$ to $5.5V$ for the MAX807M, $V_{BATT} = 2.8V$, $V_{PFI} = 0V$, $T_A = T_{MIN}$ to T_{MAX} . Typical values are tested with $V_{CC} = 5V$ and $T_A = +25^\circ C$, unless otherwise noted.)

| PARAMETER | SYMBOL | CONDITIONS | MIN | TYP | MAX | UNITS |
|--|-----------|--|-------------------------------------|------------------|------------|----------|
| PFI Input Threshold | V_{PFT} | V_{PFI} falling | 2.20 | 2.265 | 2.33 | V |
| | | V_{PFI} rising | 2.22 | 2.285 | 2.35 | |
| PFI Hysteresis | | | | 20 | | mV |
| PFI Leakage Current | | | | ± 0.005 | ± 40 | nA |
| PFI to \overline{PFO} Delay (Note 5) | | $V_{OD} = 30mV$, V_{PFI} falling | | 14 | | μs |
| CHIP-ENABLE GATING | | | | | | |
| \overline{CE} IN Leakage Current | | Disabled mode, $\overline{MR} = 0V$ | | ± 0.00002 | ± 1 | μA |
| \overline{CE} IN to \overline{CE} OUT Resistance (Note 6) | | Enabled mode, $V_{CC} = V_{RST}$ (max) | | 75 | 150 | Ω |
| \overline{CE} OUT Short-Circuit Current (RESET active) | | $V_{CC} = 5V$, disabled mode, \overline{CE} OUT = $0V$, $\overline{MR} = 0V$ | | 17 | | mA |
| \overline{CE} IN to \overline{CE} OUT Propagation Delay (Note 7) | | $V_{CC} = 5V$, $C_{LOAD} = 50pF$, 50Ω source impedance driver | | 2 | 8 | ns |
| \overline{CE} OUT Output Voltage High (RESET active) | | Disabled mode, $\overline{MR} = 0V$ | $V_{CC} = 5V$, $I_{OUT} = 2mA$ | 3.5 | | V |
| | | | $V_{CC} = 0V$, $I_{OUT} = 10\mu A$ | $V_{BATT} - 0.1$ | V_{BATT} | |
| RESET to \overline{CE} OUT Delay | | V_{CC} falling | | 28 | | μs |
| MANUAL RESET INPUT | | | | | | |
| \overline{MR} Minimum Pulse Input | | | 1 | | | μs |
| \overline{MR} -to-RESET Propagation Delay | | | | 170 | | ns |
| \overline{MR} Threshold | V_{IH} | | 2.4 | | | V |
| | V_{IL} | | | | 0.8 | |
| \overline{MR} Pull-Up Current | | $\overline{MR} = 0V$ | 50 | 100 | 200 | μA |
| BATT OK COMPARATOR | | | | | | |
| BATT OK Threshold | V_{BOK} | | 2.200 | 2.265 | 2.350 | V |
| BATT OK Hysteresis | | | | 20 | | mV |
| LOGIC OUTPUTS | | | | | | |
| Output Voltage (\overline{PFO} , BATT OK) | V_{OL} | $I_{SINK} = 3.2mA$ | | 0.4 | | V |
| | V_{OH} | $I_{SOURCE} = 5mA$ | $V_{CC} - 1.5$ | | | |
| Output Short-Circuit Current | I_{SC} | Output sink current | | 35 | | mA |
| | | Output source current | | 20 | | |

Note 1: Either V_{CC} or V_{BATT} can go to $0V$, if the other is greater than $2.0V$.

Note 2: The supply current drawn by the MAX807 from the battery (excluding I_{OUT}) typically goes to $15\mu A$ when $(V_{BATT} - 0.1V) < V_{CC} < V_{BATT}$. In most applications, this is a brief period as V_{CC} falls through this region (see *Typical Operating Characteristics*).

Note 3: "+" = battery discharging current, "-" = battery charging current.

Note 4: WDI is internally connected to a voltage divider between V_{CC} and GND. If unconnected, WDI is driven to $1.8V$ (typical), disabling the watchdog function.

Note 5: Overdrive (V_{OD}) is measured from center of hysteresis band.

Note 6: The chip-enable resistance is tested with $V_{\overline{CE} IN} = V_{CC}/2$, and $I_{\overline{CE} IN} = 1mA$.

Note 7: The chip-enable propagation delay is measured from the 50% point at $\overline{CE} IN$ to the 50% point at $\overline{CE} OUT$.

Full-Featured μP Supervisory Circuit with $\pm 1.5\%$ Reset Accuracy

Typical Operating Characteristics

($V_{CC} = 5\text{V}$, $V_{BATT} = 2.8\text{V}$, $\text{PFI} = 0\text{V}$, no load, $T_A = +25^\circ\text{C}$, unless otherwise noted.)

MAX807L/M/N

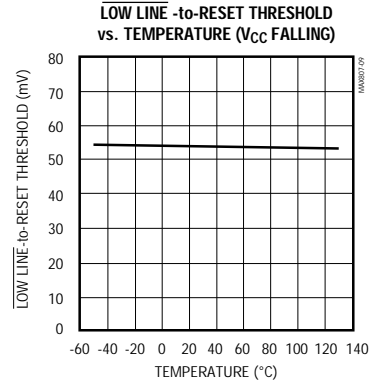
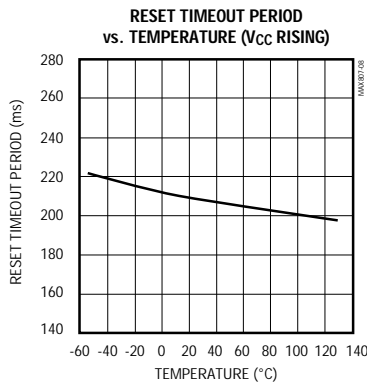
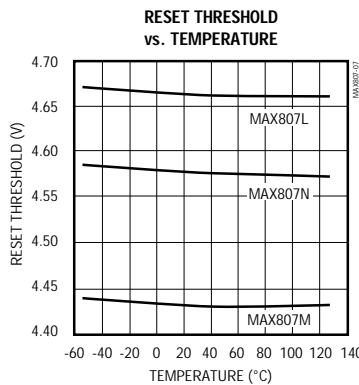
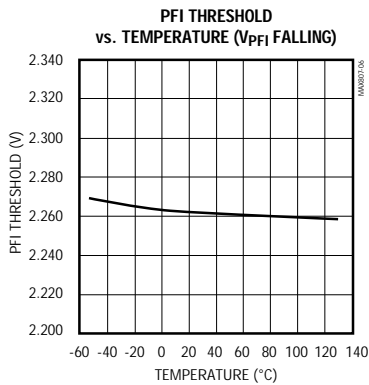
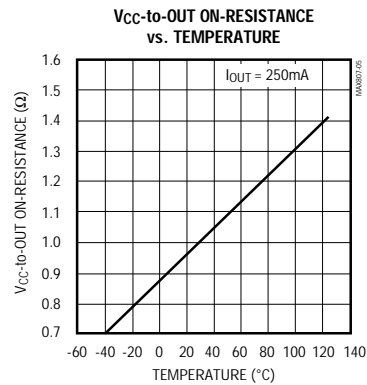
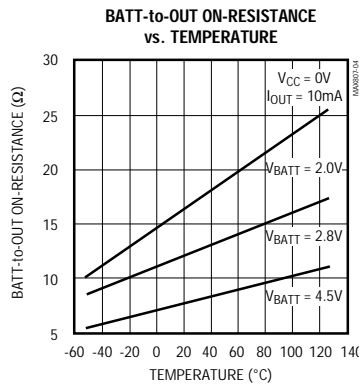
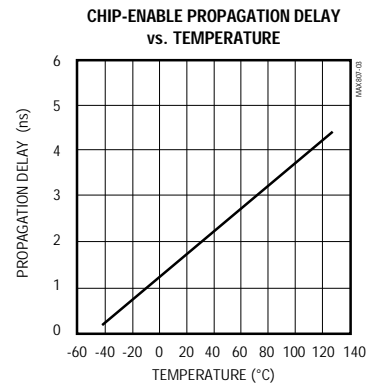
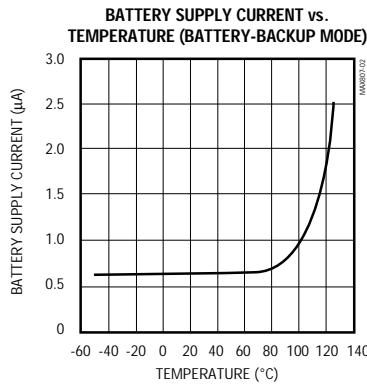
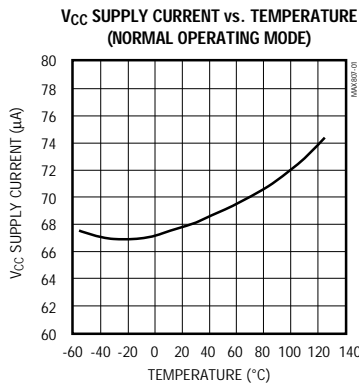

Full-Featured μ P Supervisory Circuit with $\pm 1.5\%$ Reset Accuracy

Typical Operating Characteristics (continued)

($V_{CC} = 5V$, $V_{BATT} = 2.8V$, $PFI = 0V$, no load, $T_A = +25^\circ C$, unless otherwise noted.)

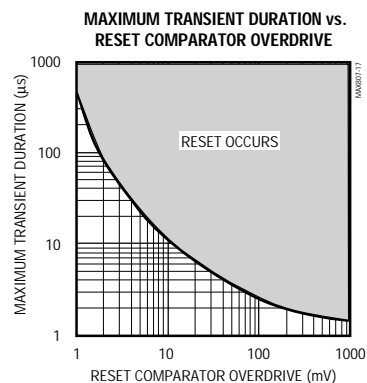
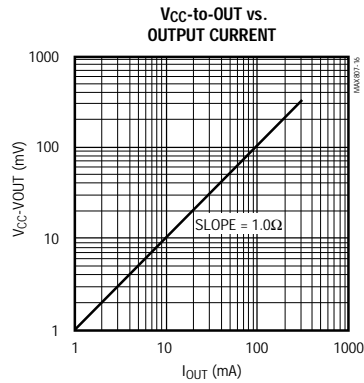
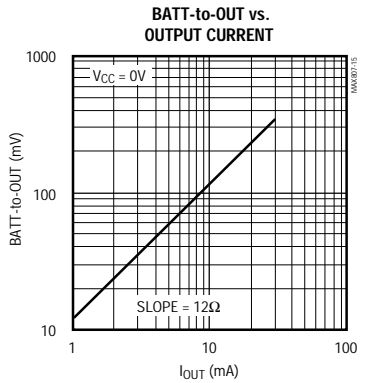
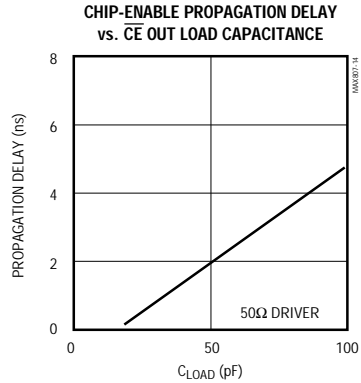
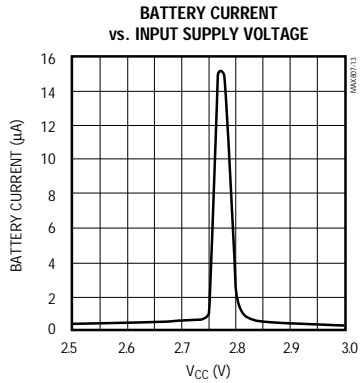
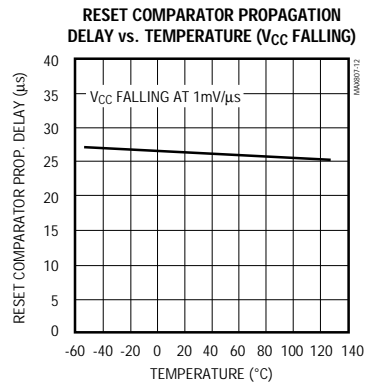
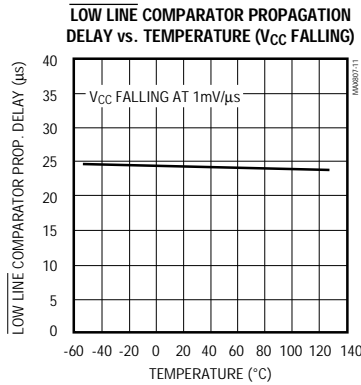
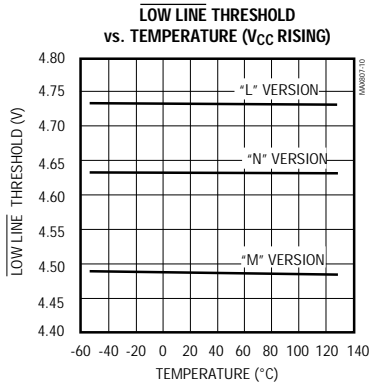

Full-Featured μ P Supervisory Circuit with $\pm 1.5\%$ Reset Accuracy

Pin Description

MAX807L/M/N

| PIN | NAME | FUNCTION |
|-----|-----------------------|---|
| 1 | PFI | Power-Fail Input. When PFI is less than V_{PFT} (2.265V), \overline{PFO} goes low. Connect to ground when unused. |
| 2 | \overline{PFO} | Power-Fail Output. This CMOS-logic output goes low when PFI is less than V_{PFT} (2.265V). Valid for $V_{CC} \geq 4V$. \overline{PFO} swings between V_{CC} and GND. |
| 3 | V_{CC} | Input Supply Voltage, nominally +5V. Bypass with a 0.1 μ F capacitor to GND. |
| 4 | WDI | Watchdog Input. If WDI remains high or low longer than the the watchdog timeout period (1.6sec typical), \overline{WDO} goes low. Leave unconnected to disable the watchdog function. |
| 5 | GND | Ground |
| 6 | \overline{MR} | Manual-Reset Input. A logic low on \overline{MR} asserts reset. Reset remains asserted as long as \overline{MR} remains low and for 200ms after \overline{MR} returns high. \overline{MR} is an active-low input with an internal pull-up to V_{CC} . It can be driven using TTL or CMOS logic, or shorted to ground with a switch. Connect to V_{CC} , or leave unconnected if not used. |
| 7 | $\overline{LOW LINE}$ | Low-Line Comparator Output. This CMOS-logic output goes low when V_{CC} falls to 52mV above the reset threshold. Use this output to generate an NMI to initiate an orderly shutdown routine when V_{CC} is falling. $\overline{LOW LINE}$ swings between V_{CC} and GND. |
| 8 | RESET | Active-High Reset Output. RESET is the inverse of \overline{RESET} . It is a CMOS output that sources and sinks current. RESET swings between V_{CC} and GND. |
| 9 | \overline{RESET} | Active-Low Reset Output. \overline{RESET} is triggered and stays low when V_{CC} is below the reset threshold or when \overline{MR} is low. It remains low 200ms after V_{CC} rises above the reset threshold or \overline{MR} returns high. \overline{RESET} has a strong pull-down but a relatively weak pull-up, and can be wire-OR connected to logic gates. Valid for $V_{CC} \geq 1V$. \overline{RESET} swings between V_{CC} and GND. |
| 10 | \overline{WDO} | Watchdog Output. This CMOS-logic output goes low if WDI remains high or low longer than the watchdog timeout period (t_{WD}), and remains low until the next transition of WDI. \overline{WDO} remains high if WDI is unconnected. \overline{WDO} is high during reset. \overline{WDO} swings between V_{CC} and GND. Connect \overline{WDO} to \overline{MR} to generate resets during watchdog faults. |
| 11 | \overline{CE} OUT | Chip-Enable Output. Output to the chip-enable gating circuit. \overline{CE} OUT is pulled up to the higher of V_{CC} or V_{BATT} , when the chip-enable gate is disabled. |
| 12 | \overline{CE} IN | Chip-Enable Input |
| 13 | BATT ON | Battery On Output. CMOS-logic output/external bypass switch driver. High when OUT is connected to BATT and low when OUT is connected to V_{CC} . Connect the base of a PNP transistor or gate of a PMOS transistor to BATT ON for I_{OUT} requirements exceeding 250mA. BATT ON swings between the higher of V_{CC} and V_{BATT} , and GND. |
| 14 | BATT | Backup-Battery Input. When V_{CC} falls below the reset threshold and V_{BATT} , OUT switches from V_{CC} to BATT. V_{BATT} may exceed V_{CC} . The battery can be removed while the MAX807 is powered-up, provided BATT is bypassed with a 0.1 μ F capacitor to GND. If no battery is used, connect BATT to ground, and connect V_{CC} and OUT together. |
| 15 | BATT OK | Battery OK Signal Output. High in normal operating mode when V_{BATT} exceeds V_{BOK} (2.265V). Valid for $V_{CC} \geq 4V$. |
| 16 | OUT | Output Supply Voltage to CMOS RAM. When V_{CC} exceeds the reset threshold or $V_{CC} > V_{BATT}$, OUT is connected to V_{CC} . When V_{CC} falls below the reset threshold and V_{BATT} , OUT connects to BATT. Bypass OUT with a 0.1 μ F capacitor to GND. |

Full-Featured μ P Supervisory Circuit with $\pm 1.5\%$ Reset Accuracy

Detailed Description

The MAX807 microprocessor (μ P) supervisory circuit provides power-supply monitoring, backup-battery switchover, and program execution watchdog functions in μ P systems (Figure 1). Use of BiCMOS technology results in an improved 1.5% reset-threshold precision, while keeping supply currents typically below 70 μ A. The MAX807 is intended for battery-powered applications that require high reset-threshold precision, allowing a wide power-supply operating range while preventing the system from operating below its specified voltage range.

$\overline{\text{RESET}}$ and RESET Outputs

The MAX807's $\overline{\text{RESET}}$ output ensures that the μ P powers up in a known state, and prevents code execution errors during power-down and brownout conditions. It accomplishes this by resetting the μ P, terminating program execution when V_{CC} dips below the reset threshold or $\overline{\text{MR}}$ is pulled low. Each time $\overline{\text{RESET}}$ is asserted it stays low for the 200ms reset timeout period, which is set by an internal timer to ensure the μ P has adequate time to return to an initial state. Any time V_{CC} goes below the reset threshold before the reset timeout period is completed, the internal timer restarts. The watchdog timer can also initiate a reset if $\overline{\text{WDO}}$ is connected to $\overline{\text{MR}}$. See the *Watchdog Input* section.

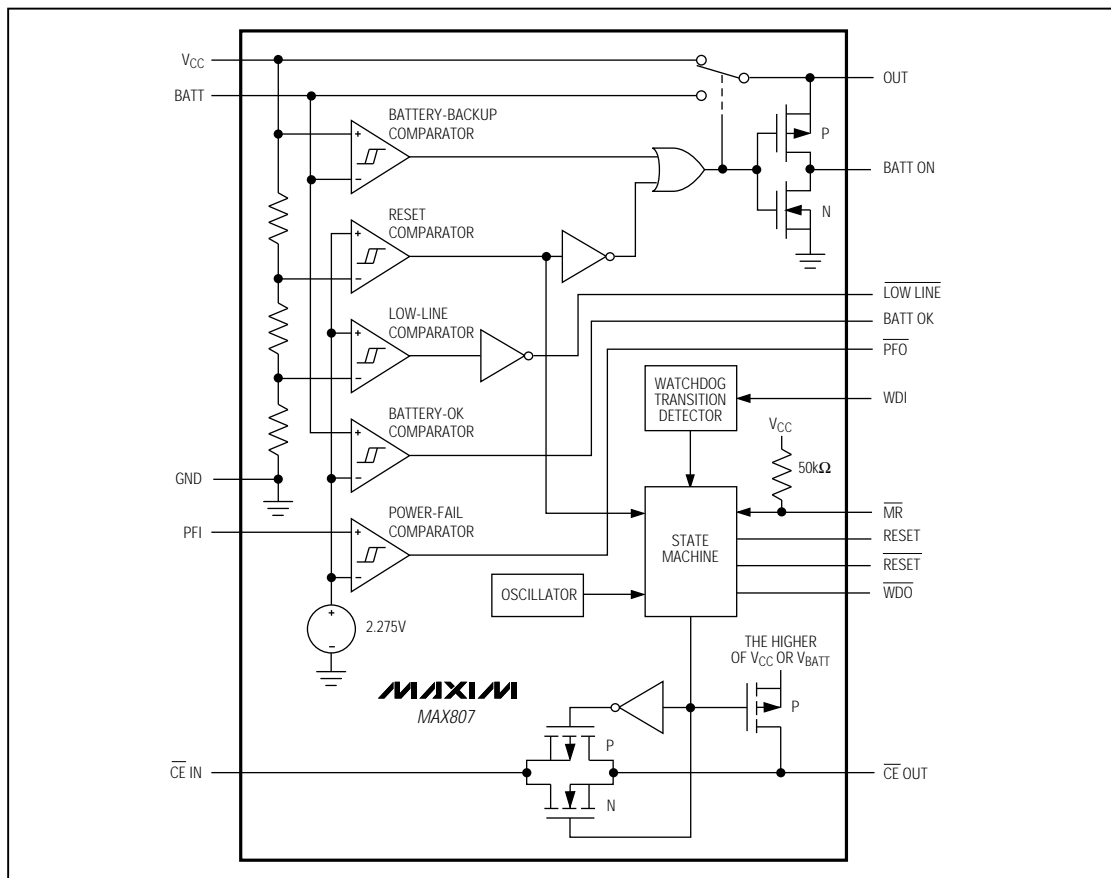

Figure 1. Block Diagram

Full-Featured μP Supervisory Circuit with $\pm 1.5\%$ Reset Accuracy

MAX807L/M/N

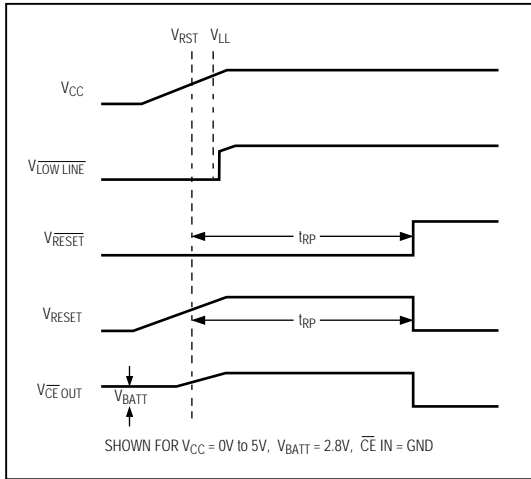

Figure 2a. Timing Diagram, V_{CC} Rising

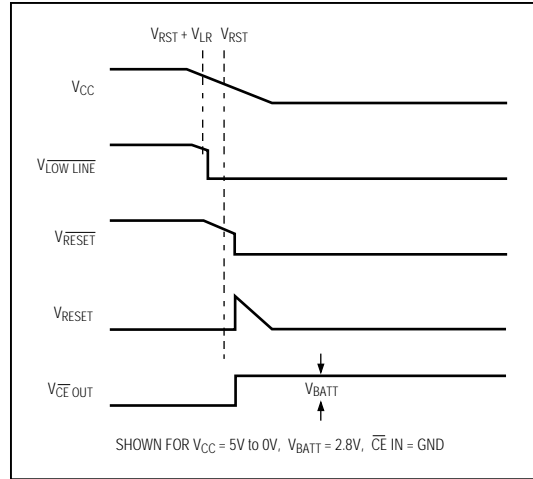

Figure 2b. Timing Diagram, V_{CC} Falling

The $\overline{\text{RESET}}$ output is active low and implemented with a strong pull-down/relatively weak pull-up structure. It is guaranteed to be a logic low for $0V < V_{CC} < V_{RST}$, provided V_{BATT} is greater than 2V. Without a backup battery, $\overline{\text{RESET}}$ is guaranteed valid for $V_{CC} \geq 1$. It typically sinks 3.2mA at 0.1V saturation voltage in its active state.

The $\overline{\text{RESET}}$ output is the inverse of the $\overline{\text{RESET}}$ output; it both sources and sinks current and cannot be wire-OR connected.

Manual Reset Input

Many μP -based products require manual-reset capability to allow an operator or test technician to initiate a reset. The Manual Reset ($\overline{\text{MR}}$) input permits the generation of a reset in response to a logic low from a switch, $\overline{\text{WDO}}$, or external circuitry. Reset remains asserted while $\overline{\text{MR}}$ is low, and for 200ms after $\overline{\text{MR}}$ returns high.

$\overline{\text{MR}}$ has an internal $50\mu A$ to $200\mu A$ pull-up current, so it can be left open if it is not used. $\overline{\text{MR}}$ can be driven with TTL or CMOS-logic levels, or with open-drain/collector outputs. Connect a normally open momentary switch from $\overline{\text{MR}}$ to GND to create a manual-reset function; external debounce circuitry is not required. If $\overline{\text{MR}}$ is driven from long cables or if the device is used in a noisy environment, connect a $0.1\mu F$ capacitor from $\overline{\text{MR}}$ to ground to provide additional noise immunity. As shown in Figure 3, diode-ORed connections can be used to allow manual resets from multiple sources. Figure 4 shows the reset timing.

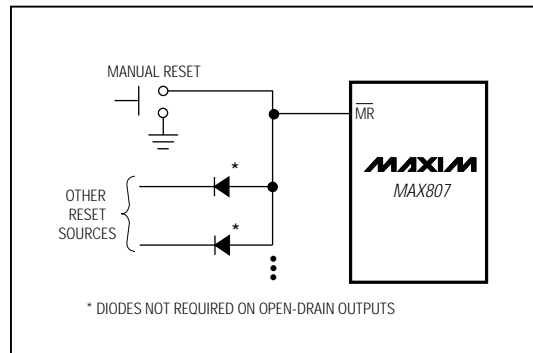

Figure 3. Diode "OR" connections allow multiple reset sources to connect to $\overline{\text{MR}}$.

Watchdog Timer

Watchdog Input

The watchdog circuit monitors the μP 's activity. If the μP does not toggle the watchdog input ($\overline{\text{WDI}}$) within 1.6sec, $\overline{\text{WDO}}$ goes low. The internal 1.6sec timer is cleared and $\overline{\text{WDO}}$ returns high when reset is asserted or when a transition (low-to-high or high-to-low) occurs at $\overline{\text{WDI}}$ while $\overline{\text{RESET}}$ is high. As long as reset is asserted, the timer remains cleared and does not count. As soon as reset is released, the timer starts counting (Figure 5). Supply current is typically reduced by $10\mu A$ when $\overline{\text{WDI}}$ is at a valid logic level.

Full-Featured μ P Supervisory Circuit with $\pm 1.5\%$ Reset Accuracy

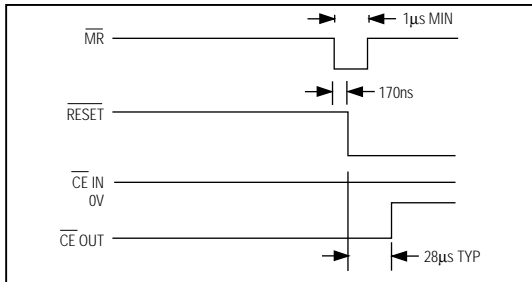

Figure 4. Manual-Reset Timing Diagram

Watchdog Output

\overline{WDO} remains high if there is a transition or pulse at \overline{WDI} during the watchdog timeout period. \overline{WDO} goes low if no transition occurs at \overline{WDI} during the watchdog timeout period. The watchdog function is disabled and \overline{WDO} is a logic high when V_{CC} is below the reset threshold or \overline{WDI} is an open circuit. To generate a system reset on every watchdog fault, simply diode-OR connect \overline{WDO} to \overline{MR} (Figure 6). When a watchdog fault occurs in this mode, \overline{WDO} goes low, which pulls \overline{MR} low, causing a reset pulse to be issued. As soon as reset is asserted, the watchdog timer clears and \overline{WDO} returns high. With \overline{WDO} connected to \overline{MR} , a continuous high or low on \overline{WDI} will cause 200ms reset pulses to be issued every 1.6sec.

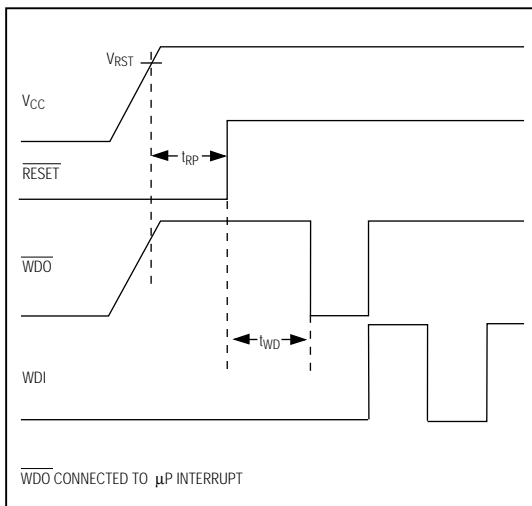

Figure 5. Watchdog Timing Relationship

Chip-Enable Signal Gating

The MAX807 provides internal gating of chip-enable (CE) signals to prevent erroneous data from corrupting the CMOS RAM in the event of a power failure. During normal operation, the CE gate is enabled and passes all CE transitions. When reset is asserted, this path becomes disabled, preventing erroneous data from corrupting the CMOS RAM. The MAX807 uses a series transmission gate from the Chip-Enable Input ($\overline{CE IN}$) to the Chip-Enable Output ($\overline{CE OUT}$) (Figure 1).

The 8ns max chip-enable propagation from $\overline{CE IN}$ to $\overline{CE OUT}$ enables the MAX807 to be used with most μ Ps.

Chip-Enable Input

$\overline{CE IN}$ is high impedance (disabled mode) while \overline{RESET} is asserted. During a power-down sequence when V_{CC} passes the reset threshold, the CE transmission gate disables and $\overline{CE IN}$ becomes high impedance 28 μ s after reset is asserted (Figure 7). During a power-up sequence, $\overline{CE IN}$ remains high impedance (regardless of CE IN activity) until reset is deasserted following the reset-timeout period.

In the high-impedance mode, the leakage currents into this input are $\pm 1\mu$ A max over temperature. In the low-impedance mode, the impedance of $\overline{CE IN}$ appears as a 75 Ω resistor in series with the load at $\overline{CE OUT}$.

The propagation delay through the CE transmission gate depends on both the source impedance of the drive to $\overline{CE IN}$ and the capacitive loading on $\overline{CE OUT}$

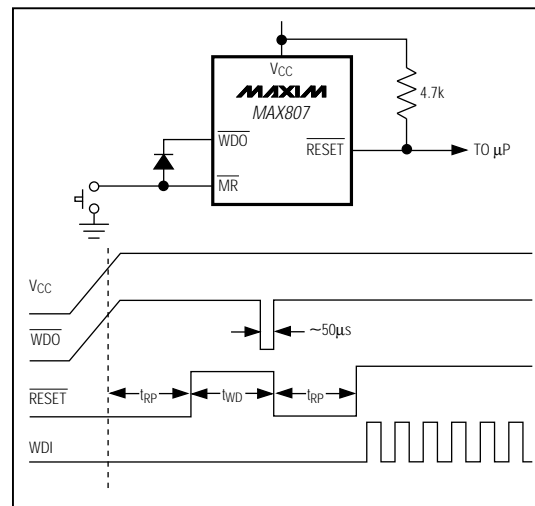

Figure 6. Generating a Reset on Each Watchdog Fault

Full-Featured μP Supervisory Circuit with $\pm 1.5\%$ Reset Accuracy

MAX807L/M/N

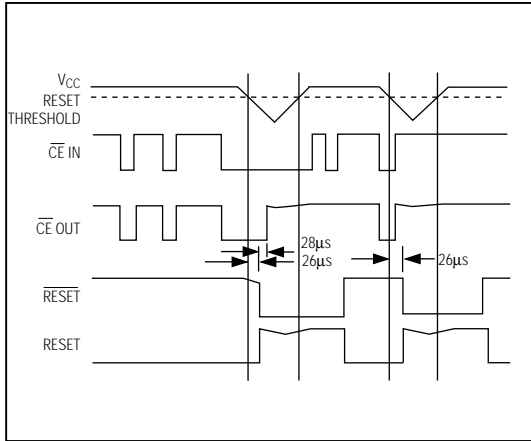

Figure 7. Reset and Chip-Enable Timing

(see the Chip-Enable Propagation Delay vs. CE OUT Load Capacitance graph in the *Typical Operating Characteristics*). The CE propagation delay is production tested from the 50% point on CE IN to the 50% point on CE OUT using a 50 Ω driver and 50pF of load capacitance (Figure 8). For minimum propagation delay, minimize the capacitive load at CE OUT and use a low output-impedance driver.

Chip-Enable Output

In the enabled mode, the impedance of CE OUT is equivalent to 75 Ω in series with the source driving CE IN. In the disabled mode, the 75 Ω transmission gate is off and CE OUT is actively pulled to the higher of VCC or VBATT. This source turns off when the transmission gate is enabled.

Low-Line Comparator

The low-line comparator monitors VCC with a threshold voltage typically 52mV above the reset threshold, with 13mV of hysteresis. Use LOW LINE to provide a non-maskable interrupt (NMI) to the μP when power begins to fall, to initiate an orderly software shutdown routine.

In most battery-operated portable systems, reserve energy in the battery provides ample time to complete the shutdown routine once the low-line warning is encountered, and before reset asserts. If the system must contend with a more rapid VCC fall time—such as when the main battery is disconnected, a DC-DC converter shuts down, or a high-side switch is opened during normal operation—use capacitance on the VCC line to provide time to execute the shutdown routine (Figure 9). First calculate the worst-case time required for the system to perform its shutdown routine. Then, with the

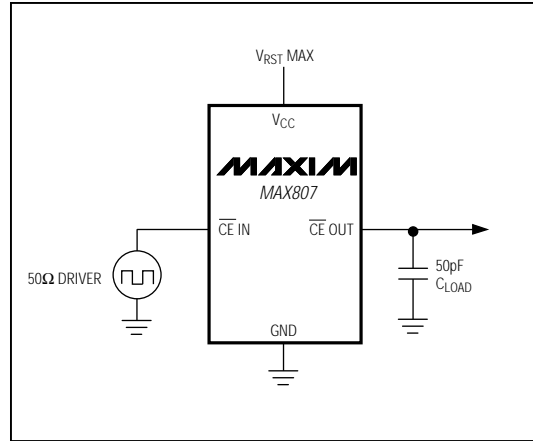

Figure 8. CE Propagation Delay Test Circuit

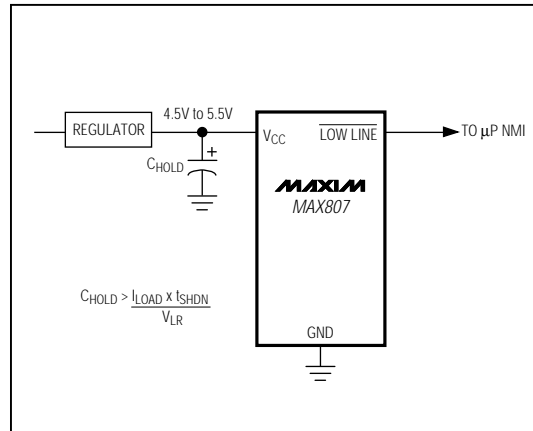

Figure 9. Using LOW LINE to Provide a Power-Fail Warning to the μP

worst-case shutdown time, the worst-case load current, and the minimum low-line to reset threshold ($V_{LR(min)}$), calculate the amount of capacitance required to allow the shutdown routine to complete before reset is asserted:

$$C_{HOLD} = (I_{LOAD} \times t_{SHDN}) / V_{LR} \text{ (min)}$$

where tSHDN is the time required for the system to complete the shutdown routine, and includes the VCC to low-line propagation delay; and where ILOAD is the current being drained from the capacitor, VLR is the low-line to reset threshold.

Full-Featured μ P Supervisory Circuit with $\pm 1.5\%$ Reset Accuracy

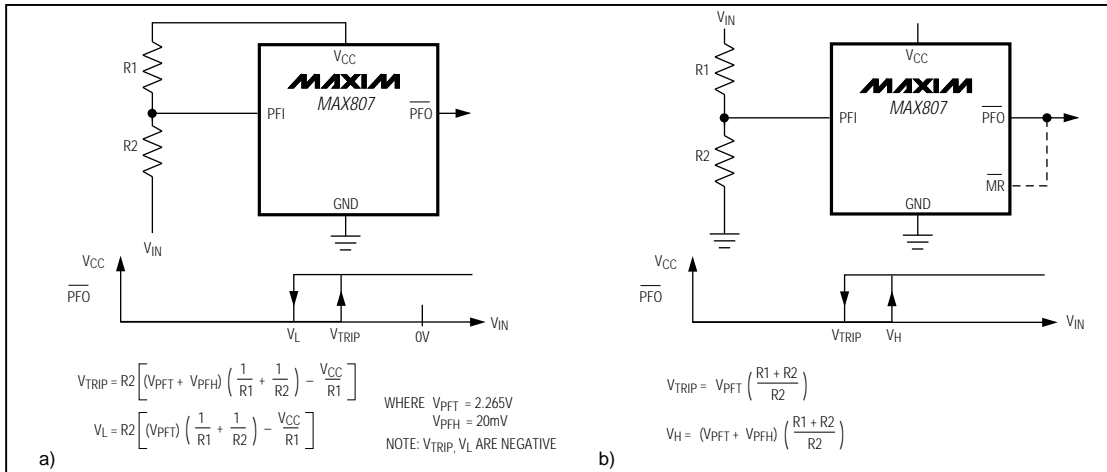

Figure 10. Using the Power-Fail Comparator to Monitor an Additional Power Supply: a) V_{IN} is Negative, b) V_{IN} is Positive

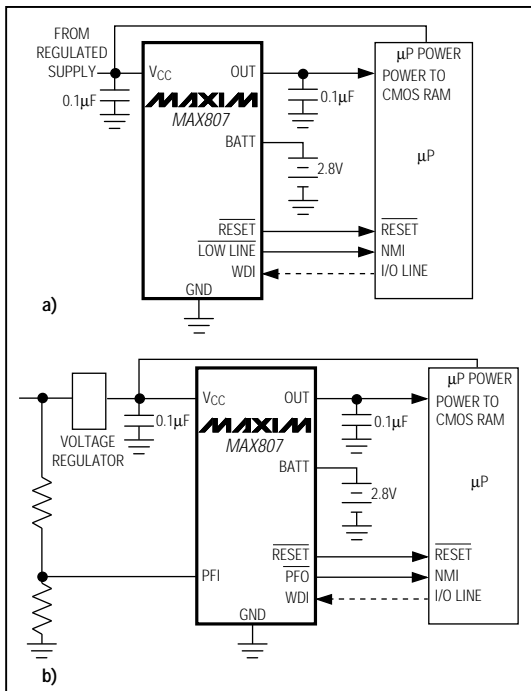

Figure 11. a) If the preregulated supply is inaccessible, **LOW LINE** generates the **NMI** for the μ P. b) Use **PFO** to generate the μ P **NMI** if the preregulated supply is accessible.

Power-Fail Comparator

PFI is the noninverting input to an uncommitted comparator. If PFI is less than V_{PFT} (2.265V), \overline{PFO} goes low. The power-fail comparator is intended to monitor the preregulated input of the power supply, providing an early power-fail warning so software can conduct an orderly shutdown. It can also be used to monitor supplies other than 5V. Set the power-fail threshold with a resistor divider, as shown in Figure 10.

Power-Fail Input

PFI is the input to the power-fail comparator. The typical comparator delay is 14 μ s from V_{IL} to V_{OL} (power failing), and 32 μ s from V_{IH} to V_{OH} (power being restored). If unused, connect this input to ground.

Power-Fail Output

The Power-Fail Output (\overline{PFO}) goes low when PFI goes below V_{PFT} . It typically sinks 3.2mA with a saturation voltage of 0.1V. With PFI above V_{PFT} , \overline{PFO} is actively pulled to V_{CC} . Connecting PFI through a voltage divider to a preregulated supply allows \overline{PFO} to generate an NMI as the preregulated power begins to fall (Figure 11b). If the preregulated supply is inaccessible, use **LOW LINE** to generate the **NMI** (Figure 11a). The **LOW LINE** threshold is typically 52mV above the reset threshold (see *Low-Line Comparator* section).

Full-Featured μP Supervisory Circuit with $\pm 1.5\%$ Reset Accuracy

MAX807L/M/N

Table 1. Input and Output Status in Battery-Backup Mode

| PIN | NAME | FUNCTION |
|-----|-----------------------------|---|
| 1 | PFI | The power-fail comparator remains active in battery-backup mode for $V_{CC} \geq 4V$. |
| 2 | $\overline{\text{PFO}}$ | The power-fail comparator remains active in battery-backup mode for $V_{CC} \geq 4V$. Below 4V, $\overline{\text{PFO}}$ is forced low. |
| 3 | V_{CC} | Battery switchover comparator monitors V_{CC} for active switchover. |
| 4 | WDI | WDI is ignored and goes high impedance. |
| 5 | GND | Ground—0V reference for all signals. |
| 6 | $\overline{\text{MR}}$ | $\overline{\text{MR}}$ is ignored. |
| 7 | $\overline{\text{LOWLINE}}$ | Logic low. |
| 8 | RESET | Logic high; the open-circuit output voltage is equal to V_{CC} . |
| 9 | $\overline{\text{RESET}}$ | Logic low. |
| 10 | WDO | Logic high. The open-circuit output voltage is equal to V_{CC} . |
| 11 | $\overline{\text{CEOUT}}$ | Logic high. The open-circuit output voltage is equal to V_{BATT} . |
| 12 | CE IN | High impedance. |
| 13 | BATT ON | Logic high. The open-circuit output voltage is equal to V_{BATT} . |
| 14 | BATT | Supply current is 1 μA maximum for $V_{BATT} \leq 2.8V$. |
| 15 | BATT OK | Logic high when V_{BATT} exceeds 2.285V. Valid for $V_{CC} \geq 4V$. Below 4V, BATT OK is forced low. |
| 16 | OUT | OUT is connected to BATT through two internal PMOS switches in series. |

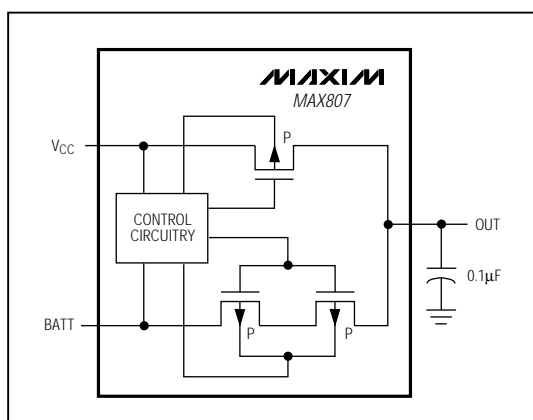

Figure 12. V_{CC} and BATT-to-OUT Switch

Battery-Backup Mode

Battery backup preserves the contents of RAM in the event of a brownout or power failure. With a backup battery installed at BATT, the MAX807 automatically switches RAM to backup power when V_{CC} falls. Two conditions are required for switchover to battery-backup mode: 1) V_{CC} must be below the reset threshold; 2) V_{CC} must be below V_{BATT} . Table 1 lists the status of inputs and outputs during battery-backup mode.

Backup-Battery Input

The BATT input is similar to V_{CC} , except the PMOS switch is much smaller. This input is designed to conduct up to 20mA to OUT during battery backup. The on-resistance of the PMOS switch is approximately 13 Ω . Figure 12 shows the two series pass elements between the BATT input and OUT that facilitates UL approval. V_{BATT} can exceed V_{CC} during normal operation without causing a reset.

Output Supply Voltage

The output supply (OUT) transfers power from V_{CC} or BATT to the μP , RAM, and other external circuitry. At the maximum source current of 250mA, V_{OUT} will typically be 260mV below V_{CC} . Decouple this terminal with a 0.1 μF capacitor.

BATT ON Output

The battery on (BATT ON) output indicates the status of the internal battery switchover comparator, which controls the internal V_{CC} and BATT switches. For V_{CC} greater than V_{BATT} (ignoring the small hysteresis effect), BATT ON typically sinks 3.2mA at 0.4V. In battery-backup mode, this output sources approximately 5mA. Use BATT ON to indicate battery switchover status, or to supply gate or base drive for an external pass transistor for higher current applications (see *Typical Operating Circuit*).

Full-Featured μ P Supervisory Circuit with $\pm 1.5\%$ Reset Accuracy

BATT OK Output

The BATT OK comparator monitors the backup battery voltage, comparing it with a 2.265V reference ($V_{CC} \geq 4V$). BATT OK remains high as long as the backup battery voltage remains above 2.265V, signaling that the backup battery has sufficient voltage to maintain the memory of static RAM. When the battery voltage drops below 2.265V, the BATT OK output drops low, signaling that the backup battery needs to be changed.

Applications Information

The MAX807 is not short-circuit protected. Shorting OUT to ground, other than power-up transients such as charging a decoupling capacitor, may destroy the device. If long leads connect to the IC's inputs, ensure that these lines are free from ringing and other conditions that would forward bias the IC's protection diodes.

There are two distinct modes of operation:

- 1) Normal Operating Mode, with all circuitry powered up. Typical supply current from V_{CC} is $70\mu A$, while only leakage currents flow from the battery.
- 2) Battery-Backup Mode, where V_{CC} is below V_{BATT} and V_{RST} . The supply current from the battery is typically less than $1\mu A$.

Using SuperCaps™ or MaxCaps™ with the MAX807

BATT has the same operating voltage range as V_{CC} , and the battery-switchover threshold voltage is typically V_{BATT} when V_{CC} is decreasing or $V_{BATT} + 0.06V$ when V_{CC} is increasing. This hysteresis allows use of a

SuperCap (e.g., order of 0.47F) and a simple charging circuit as a backup source (Figure 13). Since V_{BATT} can exceed V_{CC} while V_{CC} is above the reset threshold, there are no special precautions when using these μ P supervisors with a SuperCap.

Alternative Chip-Enable Gating

Using memory devices with \overline{CE} and CE inputs allows the MAX807 CE loop to be bypassed. To do this, connect \overline{CE} IN to ground, pull up \overline{CE} OUT to OUT, and connect \overline{CE} OUT to the CE input of each memory device (Figure 14). The CE input of each part then connects directly to the chip-select logic, which does not have to be gated by the MAX807.

Adding Hysteresis to the Power-Fail Comparator

The power-fail comparator has a typical input hysteresis of 20mV. This is sufficient for most applications where a power-supply line is being monitored through an external voltage divider (Figure 10).

Figure 15 shows how to add hysteresis to the power-fail comparator. Select the ratio of R1 and R2 such that PFI sees 2.265V when V_{IN} falls to the desired trip point (V_{TRIP}). Resistor R3 adds hysteresis. It will typically be an order of magnitude greater than R1 or R2. The current through R1 and R2 should be at least $1\mu A$ to ensure that the 25nA (max) PFI input current does not shift the trip point. R3 should be larger than $10k\Omega$ to prevent it from loading down the PFO pin. Capacitor C1 adds additional noise rejection.

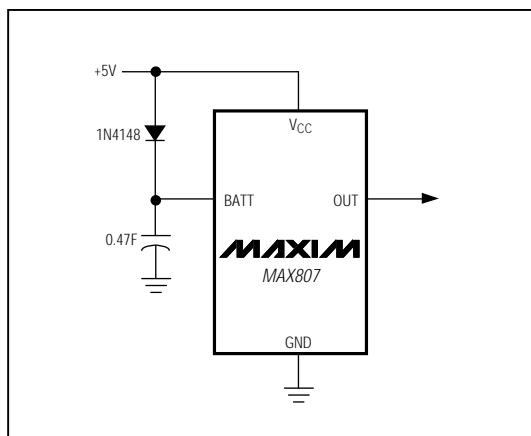

Figure 13. SuperCap or MaxCap on BATT

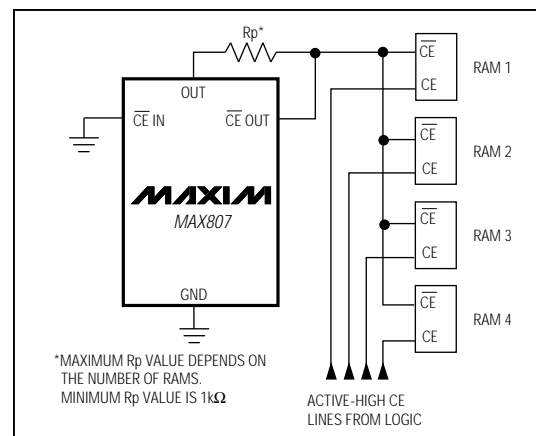

Figure 14. Alternate CE Gating

Full-Featured μP Supervisory Circuit with $\pm 1.5\%$ Reset Accuracy

Backup-Battery Replacement

The backup battery may be disconnected while V_{CC} is above the reset threshold, provided BATT is bypassed with a $0.1\mu F$ capacitor to ground. No precautions are necessary to avoid spurious reset pulses.

Negative-Going V_{CC} Transients

While issuing resets to the μP during power-up, power-down, and brownout conditions, these supervisors are relatively immune to short-duration negative-going V_{CC} transients (glitches). It is usually undesirable to reset the μP when V_{CC} experiences only small glitches.

The *Typical Operating Characteristics* show Maximum Transient Duration vs. Reset Comparator Overdrive, for which reset pulses are not generated. The graph was produced using negative-going V_{CC} pulses, starting at 5V and ending below the reset threshold by the magnitude indicated (reset comparator overdrive). The graph shows the maximum pulse width that a negative-going V_{CC} transient may typically have without causing a reset pulse to be issued. As the amplitude of the transient increases (i.e., goes farther below the reset threshold), the maximum allowable pulse width decreases.

Typically, a V_{CC} transient that goes 40mV below the reset threshold and lasts for 3 μs or less will not cause a reset pulse to be issued.

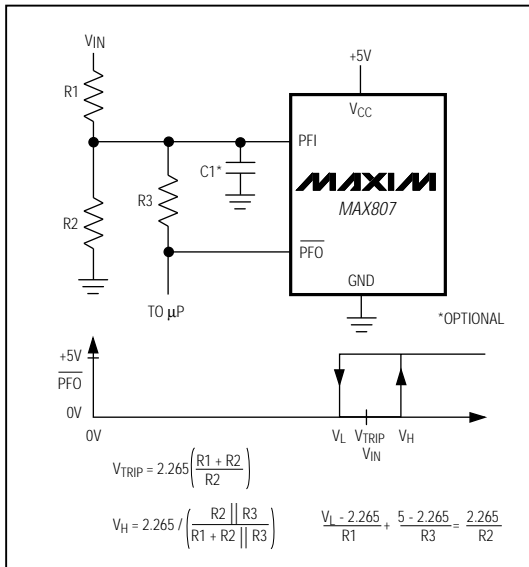

Figure 15. Adding Hysteresis to the Power-Fail Comparator

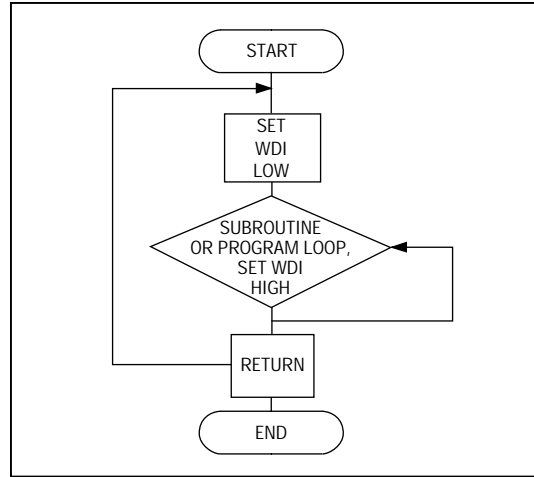

Figure 16. Watchdog Flow Diagram

A $0.1\mu F$ bypass capacitor mounted close to the V_{CC} pin provides additional transient immunity.

Watchdog Software Considerations

To help the watchdog timer keep a closer watch on software execution, you can use the method of setting and resetting the watchdog input at different points in the program, rather than “pulsing” the watchdog input high-low-high or low-high-low. This technique avoids a “stuck” loop where the watchdog timer continues to be reset within the loop, keeping the watchdog from timing out.

Figure 16 shows an example flow diagram where the I/O driving the watchdog input is set high at the beginning of the program, set low at the beginning of every subroutine or loop, then set high again when the program returns to the beginning. If the program should “hang” in any subroutine, the I/O is continually set low and the watchdog timer is allowed to time out, causing a reset or interrupt to be issued.

Maximum V_{CC} Fall Time

The V_{CC} fall time is limited by the propagation delay of the battery switchover comparator and should not exceed $0.03V/\mu s$. A standard rule for filter capacitance on most regulators is on the order of $100\mu F$ per amp of current. When the power supply is shut off or the main battery is disconnected, the associated initial V_{CC} fall rate is just the inverse or $1A / 100\mu F = 0.01V/\mu s$. The V_{CC} fall rate decreases with time as V_{CC} falls exponentially, which more than satisfies the maximum fall-time requirement.

MAX807L/M/N

Full-Featured μ P Supervisory Circuit with $\pm 1.5\%$ Reset Accuracy

MAX807L/M/N

Typical Operating Circuit

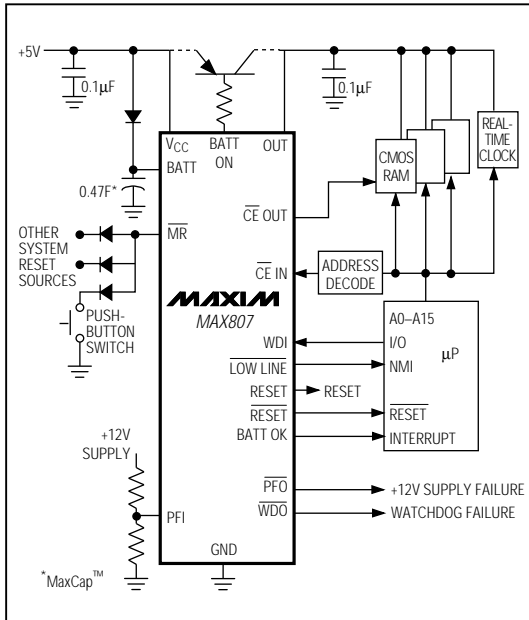

Ordering Information

| PART [†] | TEMP. RANGE | PIN-PACKAGE |
|-------------------|-----------------|----------------|
| MAX807_CPE | 0°C to +70°C | 16 Plastic DIP |
| MAX807_CWE | 0°C to +70°C | 16 Wide SO |
| MAX807_EPE | -40°C to +85°C | 16 Plastic DIP |
| MAX807_EWE | -40°C to +85°C | 16 Wide SO |
| MAX807_MJE | -55°C to +125°C | 16 CERDIP |

[†] This part offers a choice of reset threshold voltage. From the table below, select the suffix corresponding to the desired threshold and insert it into the blank to complete the part number.

| SUFFIX | RESET THRESHOLD (V) | | |
|--------|---------------------|-------|------|
| | MIN | TYP | MAX |
| L | 4.60 | 4.675 | 4.75 |
| N | 4.50 | 4.575 | 4.65 |
| M | 4.35 | 4.425 | 4.50 |

Chip Information

TRANSISTOR COUNT: 984

Maxim cannot assume responsibility for use of any circuitry other than circuitry entirely embodied in a Maxim product. No circuit patent licenses are implied. Maxim reserves the right to change the circuitry and specifications without notice at any time.

16 Maxim Integrated Products, 120 San Gabriel Drive, Sunnyvale, CA 94086 (408) 737-7600

© 1995 Maxim Integrated Products

Printed USA

MAXIM is a registered trademark of Maxim Integrated Products.