

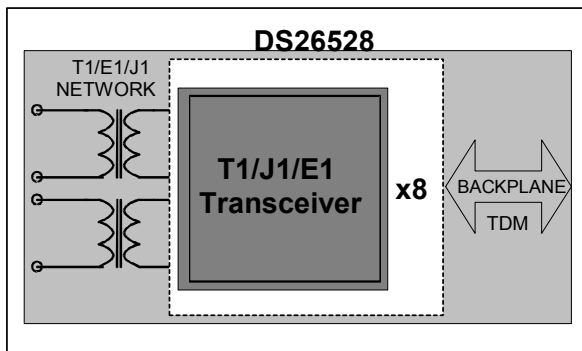
GENERAL DESCRIPTION

The DS26528 is a single-chip 8-port framer and line interface unit (LIU) combination for T1, E1, and J1 applications. Each port is independently configurable, supporting both long-haul and short-haul lines.

APPLICATIONS

Routers
 Channel Service Units (CSUs)
 Data Service Units (DSUs)
 Muxes
 Switches
 Channel Banks
 T1/E1 Test Equipment

FUNCTIONAL DIAGRAM



FEATURES

- Eight Complete T1, E1, or J1 Long-Haul/Short-Haul Transceivers (LIU plus Framer)
- Independent T1, E1, or J1 Selections for Each Transceiver
- Internal Software-Selectable Transmit- and Receive-Side Termination for 100Ω T1 Twisted Pair, 110Ω J1 Twisted Pair, 120Ω E1 Twisted Pair, and 75Ω E1 Coaxial Applications
- Crystal-Less Jitter Attenuators can be Selected for Transmit or Receive Path. The Jitter Attenuator meets ETSI CTR 12/13, ITU G.736, G.742, G.823, and AT&T PUB 62411.
- External Master Clock can be Multiple of 2.048MHz or 1.544MHz for T1/J1 or E1 operation. This Clock is Internally Adapted for T1 or E1 Usage in the Host Mode.
- Receive Signal Level Indication from -2.5dB to -36dB in T1 Mode and -2.5dB to -44dB in E1 Mode in Approximate 2.5dB Increments
- Transmit Open and Short Circuit Detection
- LIU LOS in Accordance with G.775, ETSI 300233, and T1.231
- Transmit Synchronizer
- Flexible Signaling Extraction and Insertion Using Either the System Interface or Microprocessor Port
- Alarm Detection and Insertion
- T1 Framing Formats of D4, SLC-96, and ESF
- J1 Support
- E1 G.704 and CRC-4 Multiframe
- T1 to E1 Conversion

Features continued on in Section 2.

ORDERING INFORMATION

PART	TEMP RANGE	PIN-PACKAGE
DS26528	-40°C to +85°C	256 TE-CSBGA

Note: Some revisions of this device may incorporate deviations from published specifications known as errata. Multiple revisions of any device may be simultaneously available through various sales channels. For information about device errata, click here: www.maxim-ic.com/errata.

TABLE OF CONTENTS

1.	DETAILED DESCRIPTION	8
2.	FEATURE HIGHLIGHTS	9
2.1	GENERAL.....	9
2.2	LINE INTERFACE	9
2.3	CLOCK SYNTHESIZER	9
2.4	JITTER ATTENUATOR	9
2.5	FRAMER/FORMATTER	9
2.6	SYSTEM INTERFACE	10
2.7	HDLC CONTROLLERS	10
2.8	TEST AND DIAGNOSTICS	11
2.9	CONTROL PORT	11
3.	APPLICATIONS	11
4.	SPECIFICATIONS COMPLIANCE	12
5.	ACRONYMS AND GLOSSARY	14
6.	MAJOR OPERATING MODES	15
7.	BLOCK DIAGRAMS	15
8.	PIN DESCRIPTIONS	17
8.1	PIN FUNCTIONAL DESCRIPTION	17
9.	FUNCTIONAL DESCRIPTION	23
9.1	PROCESSOR INTERFACE	23
9.2	CLOCK STRUCTURE.....	23
9.3	RESETS AND POWER-DOWN MODES	25
9.4	INITIALIZATION AND CONFIGURATION	26
9.5	GLOBAL RESOURCES.....	26
9.6	PER-PORT RESOURCES.....	26
9.7	DEVICE INTERRUPTS	27
9.8	SYSTEM BACKPLANE INTERFACE.....	29
9.8.1	<i>Elastic Stores</i>	29
9.8.2	<i>IBO Multiplexer</i>	32
9.8.3	<i>H.100 (CT-Bus) Compatibility</i>	39
9.8.4	<i>Transmit and Receive Channel Blocking Registers</i>	40
9.8.5	<i>Transmit Fractional Support (Gapped Clock Mode)</i>	40
9.8.6	<i>Receive Fractional Support (Gapped Clock Mode)</i>	40
9.9	FRAMERS.....	41
9.9.1	<i>T1 Framing</i>	41
9.9.2	<i>E1 Framing</i>	44
9.9.3	<i>T1 Transmit Synchronizer</i>	46
9.9.4	<i>Signaling</i>	47
9.9.5	<i>T1 Datalink</i>	52
9.9.6	<i>E1 Datalink</i>	54
9.9.7	<i>Maintenance and Alarms</i>	55
9.9.8	<i>E1 Automatic Alarm Generation</i>	58
9.9.9	<i>Error Count Registers</i>	59
9.9.10	<i>DS0 Monitoring Function</i>	61
9.9.11	<i>Transmit Per-Channel Idle Code Insertion</i>	62
9.9.12	<i>Receive Per-Channel Idle Code Insertion</i>	62
9.9.13	<i>Per-Channel Loopback</i>	62
9.9.14	<i>E1 G.706 Intermediate CRC-4 Updating (E1 Mode Only)</i>	62
9.9.15	<i>T1 Programmable In-Band Loop Code Generator</i>	63

9.9.16	<i>Framer Payload Loopbacks</i>	65
9.10	HDLC CONTROLLERS	66
9.10.1	<i>Receive HDLC Controller</i>	66
9.10.2	<i>Transmit HDLC Controller</i>	69
9.10.3	<i>FIFO Information</i>	69
9.10.4	<i>HDLC Transmit Example</i>	69
9.11	LINE INTERFACE UNITS (LIU)	71
9.11.1	<i>LIU Operation</i>	72
9.11.2	<i>Transmitter</i>	73
9.11.3	<i>Receiver</i>	76
9.11.4	<i>Jitter Attenuator</i>	78
9.11.5	<i>LIU Loopbacks</i>	80
9.12	BIT ERROR RATE TEST FUNCTION (BERT)	83
9.12.1	<i>BERT Repetitive Pattern Set</i>	84
9.12.2	<i>BERT Error Counter</i>	84
10.	DEVICE REGISTERS	85
10.1	REGISTER LISTINGS	85
10.1.1	<i>Global Register List</i>	87
10.1.2	<i>Framer Register List</i>	87
10.1.3	<i>LIU and BERT Register List</i>	94
10.2	REGISTER BIT MAPS	95
10.2.1	<i>Global Register Bit Map</i>	95
10.2.2	<i>Framer Register Bit Map</i>	96
10.2.3	<i>LIU Register Bit Map</i>	102
10.2.4	<i>BERT Register Bit Map</i>	103
10.3	GLOBAL REGISTER DEFINITIONS	104
10.4	FRAMER REGISTER DEFINITIONS	118
10.4.1	<i>Receive Register Definitions</i>	118
10.4.2	<i>Transmit Register Definitions</i>	172
10.5	LIU REGISTER DEFINITIONS	207
10.6	BERT REGISTER DEFINITIONS	216
11.	FUNCTIONAL TIMING	224
11.1	T1 RECEIVER FUNCTIONAL TIMING DIAGRAMS	224
11.2	T1 TRANSMITTER FUNCTIONAL TIMING DIAGRAMS	229
11.3	E1 RECEIVER FUNCTIONAL TIMING DIAGRAMS	234
11.4	E1 TRANSMITTER FUNCTIONAL TIMING DIAGRAMS	236
12.	OPERATING PARAMETERS	239
12.1	LINE INTERFACE CHARACTERISTICS	240
13.	AC TIMING CHARACTERISTICS	241
13.1	MICROPROCESSOR BUS AC CHARACTERISTICS	241
13.2	JTAG INTERFACE TIMING	250
13.3	SYSTEM CLOCK AC CHARACTERISTICS	251
14.	JTAG-BOUNDARY SCAN AND TEST ACCESS PORT	252
14.1	INSTRUCTION REGISTER	256
14.2	JTAG ID CODES	257
14.3	TEST REGISTERS	257
14.4	BOUNDARY SCAN REGISTER	257
14.5	BYPASS REGISTER	257
14.6	IDENTIFICATION REGISTER	257
15.	DOCUMENT REVISION HISTORY	261
16.	PACKAGE INFORMATION	262

LIST OF FIGURES

Figure 7-1. Block Diagram	15
Figure 7-2. Detailed Block Diagram	16
Figure 8-1. BGA Pinout	22
Figure 9-1. Backplane Clock Generation	24
Figure 9-2. Device Interrupt Information Flow Diagram	28
Figure 9-3. IBO Multiplexer Equivalent Circuit—4.096MHz	33
Figure 9-4. IBO Multiplexer Equivalent Circuit—8.192MHz	34
Figure 9-5. IBO Multiplexer Equivalent Circuit—16.384MHz	35
Figure 9-6. RSYNC Input In H.100 (Ct-Bus) Mode	39
Figure 9-7. TSSYNCIO(Input Mode) Input In H.100 (CT-Bus) Mode	40
Figure 9-8. CRC-4 Recalculate Method	62
Figure 9-9. Receive HDLC Example	68
Figure 9-10. HDLC Message Transmit Example	70
Figure 9-11. Basic Balanced Network Connections	71
Figure 9-12. Recommended Supply Decoupling	72
Figure 9-13. T1/J1 Transmit Pulse Templates	74
Figure 9-14. E1 Transmit Pulse Templates	75
Figure 9-15. Typical Monitor Application	77
Figure 9-16. Jitter Attenuation	80
Figure 9-17. Analog Loopback	80
Figure 9-18. Local Loopback	81
Figure 9-19. Remote Loopback	81
Figure 9-20. Dual Loopback	82
Figure 10-1. Register Memory Map for the DS26528	86
Figure 11-1. T1 Receive Side D4 Timing	224
Figure 11-2. T1 Receive Side ESF Timing	224
Figure 11-3. T1 Receive Side Boundary Timing (elastic store disabled)	225
Figure 11-4. T1 Receive Side 1.544MHz Boundary Timing (e-store enabled)	225
Figure 11-5. T1 Receive Side 2.048MHz Boundary Timing (e-store enabled)	226
Figure 11-6. T1 Receive Side Interleave Bus Operation, BYTE Mode	227
Figure 11-7. T1 Receive Side Interleave Bus Operation, FRAME Mode	228
Figure 11-8. T1 Transmit Side D4 Timing	229
Figure 11-9. T1 Transmit Side ESF Timing	229
Figure 11-10. T1 Transmit Side Boundary Timing (e-store disabled)	230
Figure 11-11. T1 Transmit Side 1.544MHz Boundary Timing (e-store enabled)	230
Figure 11-12. T1 Transmit Side 2.048MHz Boundary Timing (e-store enabled)	231
Figure 11-13. T1 Transmit Side Interleave Bus Operation, BYTE Mode	232
Figure 11-14. T1 Transmit Interleave Bus Operation, FRAME Mode	233
Figure 11-15. E1 Receive Side Timing	234
Figure 11-16. E1 Receive Side Boundary Timing (elastic store disabled)	234
Figure 11-17. E1 Receive Side 1.544MHz Boundary Timing (e-store enabled)	235
Figure 11-18. E1 Receive Side 2.048MHz Boundary Timing (e-store enabled)	235
Figure 11-19. E1 Transmit Side Timing	236
Figure 11-20. E1 Transmit Side Boundary Timing (elastic store disabled)	236
Figure 11-21. E1 Transmit Side 1.544MHz Boundary Timing (e-store enabled)	237
Figure 11-22. E1 Transmit Side 2.048MHz Boundary Timing (e-store enabled)	237
Figure 11-23. E1 G.802 Timing	238
Figure 13-1. Intel Bus Read Timing (BTS = 0)	242
Figure 13-2. Intel Bus Write Timing (BTS = 0)	242
Figure 13-3. Motorola Bus Read Timing (BTS = 1)	243
Figure 13-4. Motorola Bus Write Timing (BTS = 1)	243
Figure 13-5. Receive Framing Timing—Backplane (T1 Mode)	245
Figure 13-6. Receive Side Timing, Elastic Store Enabled (T1 Mode)	246
Figure 13-7. Receive Framing Timing—Line Side	246
Figure 13-8. Transmit Formatter Timing—Backplane	248
Figure 13-9. Transmit Formatter Timing, Elastic Store Enabled	249

Figure 13-10. Transmit Formatter Timing—Line Side 249
Figure 13-11. JTAG Interface Timing Diagram..... 250
Figure 14-1. JTAG Functional Block Diagram 252
Figure 14-2. Tap Controller State Diagram 255

LIST OF TABLES

Table 4-1. T1-Related Telecommunications Specifications	12
Table 4-2. E1-Related Telecommunications Specifications	13
Table 8-1. Detailed Pin Descriptions	17
Table 9-1. Reset Functions.....	25
Table 9-2. Registers Related to the Elastic Store.....	29
Table 9-3. Elastic Store Delay After Initialization.....	30
Table 9-4. Registers related to the IBO Multiplexer.....	32
Table 9-5. RSER Output Pin Definitions.....	36
Table 9-6. RSIG Output Pin Definitions.....	36
Table 9-7. TSER Input Pin Definitions.....	37
Table 9-8. TSIG Input Pin Definitions.....	37
Table 9-9. RSYNC Input Pin Definitions.....	38
Table 9-10. D4 Framing Mode.....	42
Table 9-11. ESF Framing Mode	42
Table 9-12. SLC-96 Framing	43
Table 9-13. E1 FAS/NFAS Framing	44
Table 9-14. Registers Related to Setting Up the Framer	45
Table 9-15. Registers Related to the Transmit Synchronizer.....	46
Table 9-16. Registers Related to Signaling	47
Table 9-17. Registers Related to SLC96.....	50
Table 9-18. Registers Related to T1 Transmit BOC.....	52
Table 9-19. Registers Related to T1 Receive BOC.....	52
Table 9-20. Registers Related to T1 Transmit FDL.....	53
Table 9-21. Registers Related to T1 Receive FDL.....	54
Table 9-22. Registers Related to Maintenance and Alarms.....	56
Table 9-23. T1 Alarm Criteria	58
Table 9-24. T1 Line Code Violation Counting Options	59
Table 9-25. E1 Line Code Violation Counting Options.....	60
Table 9-26. T1 Path Code Violation Counting Arrangements	60
Table 9-27. T1 Frames Out Of Sync Counting Arrangements.....	61
Table 9-28. Registers Related to DS0 Monitoring	61
Table 9-29. Registers Related to T1 In-Band Loop Code Generator.....	63
Table 9-30. Registers Related to T1 In-Band Loop Code Detection.....	64
Table 9-31. Register Related to Framer Payload Loopbacks	65
Table 9-32. Registers Related to Control of DS26528 LIU.....	72
Table 9-33. The Telecommunications Specification Compliance for DS26528 Transmitters	73
Table 9-34. Transformer Specifications.....	73
Table 9-35. T1.231, G.775, and ETSI 300 233 Loss Criteria Specifications.....	77
Table 9-36. Jitter Attenuator Standards Compliance.....	79
Table 10-1. Register Address Ranges (in Hex).....	85
Table 10-2. Global Register List	87
Table 10-3. Framer Register List.....	87
Table 10-4. LIU Register List.....	94
Table 10-5. BERT Register List.....	94
Table 10-6. Global Register Bit Map.....	95
Table 10-7. Framer Register Bit Map	96
Table 10-8. LIU Register Bit Map	102
Table 10-9. BERT Register Bit Map	103
Table 10-10. Backplane Reference Clock Select.....	107
Table 10-11. Master Clock Input Selection.....	108
Table 10-12. Device ID Codes in this Product Family.....	111
Table 10-13. LIU Register Set	207
Table 10-14. Transmit Load Impedance Selection.....	208
Table 10-15. Transmit Pulse Shape Selection	208
Table 10-16. Receive Level Indication	213
Table 10-17. Receive Impedance Selection.....	214

Table 10-18. Receiver Sensitivity Selection with Monitor Mode Disabled.....	215
Table 10-19. Receiver Sensitivity Selection with Monitor Mode Enabled	215
Table 10-20. BERT Register Set	216
Table 10-21. BERT Pattern Select	218
Table 10-22. BERT Error Insertion Rate.....	219
Table 10-23. BERT Repetitive Pattern Length Select	219
Table 12-1. Transmitter Characteristics	240
Table 12-2. Receiver Characteristics.....	240
Table 13-1. AC Characteristics –Microprocessor Bus Timing	241
Table 13-2. Receiver AC Characteristics	244
Table 13-3. Transmit AC Characteristics.....	247
Table 14-1. Instruction Codes for IEEE 1149.1 Architecture.....	256
Table 14-2. ID Code Structure.....	257
Table 14-3. Boundary Scan Control Bits	257

1. DETAILED DESCRIPTION

The DS26528 is an 8-port monolithic device featuring independent transceivers that can be software configured for T1, E1, or J1 operation. Each transceiver is composed of a line interface unit, framer, HDLC controller, elastic store, and a TDM backplane interface. The DS26528 is controlled via an 8-bit parallel port. Internal impedance matching is provided for both transmit and receive paths, reducing external component count.

The LIU is composed of a transmit interface, receive interface, and a jitter attenuator. The transmit interface is responsible for generating the necessary waveshapes for driving the network and providing the correct source impedance depending on the type of media used. T1 waveform generation includes DSX-1 line build-outs as well as CSU line build-outs of 0dB, -7.5dB, -15dB, and -22.5dB. E1 waveform generation includes G.703 waveshapes for both 75Ω coax and 120Ω twisted cables. The receive interface provides network termination and recovers clock and data from the network. The receive sensitivity adjusts automatically to the incoming signal level and can be programmed for 0dB to -43dB or 0dB to -12dB for E1 applications and 0dB to -15dB or 0dB to -36dB for T1 applications. The jitter attenuator removes phase jitter from the transmitted or received signal. The crystal-less jitter attenuator requires only a T1 or E1 clock rate, or multiple thereof, for both E1 and T1 applications, and can be placed in either transmit or receive data paths.

On the transmit side, clock, data, and frame-sync signals are provided to the framer by the backplane interface section. The framer inserts the appropriate synchronization framing patterns, alarm information, calculates and inserts the CRC codes, and provides the B8ZS/HDB3 (zero code suppression) and AMI line coding. The receive-side framer decodes AMI, B8ZS, and HDB3 line coding, synchronizes to the data stream, reports alarm information, counts framing/coding/CRC errors, and provides clock, data, and frame-sync signals to the backplane interface section.

Both transmit and receive paths have access to an HDLC controller. The HDLC controller transmits and receives data via the framer block. The HDLC controller can be assigned to any time slot, a portion of a time slot or to FDL (T1) or Sa bits (E1). Each controller has 64-byte FIFOs, reducing the amount of processor overhead required to manage the flow of data.

The backplane interface provides a versatile method of sending and receiving data from the host system. Elastic stores provide a method for interfacing to asynchronous systems, converting from a T1/E1 network to a 2.048MHz, 4.096MHz, 8.192MHz, 16.384MHz, or N x 64kHz system backplane. The elastic stores also manage slip conditions (asynchronous interface). An interleave bus option (IBO) is provided to allow up to eight transceivers (single DS26528) to share a high-speed backplane. The DS26528 also contains an internal clock adapter useful for the creation of a synchronous, high-frequency backplane timing source.

The parallel port provides access for configuration and status of all the DS26528's features. Diagnostic capabilities include loopbacks, PRBS pattern generation/detection, and 16-bit loop-up and loop-down code generation and detection.

2. FEATURE HIGHLIGHTS

2.1 General

- 17mm x 17mm, 256-pin TE-CSBGA (1.00mm pitch)
- 3.3V supply with 5V tolerant inputs and outputs
- IEEE 1149.1 JTAG boundary scan
- Development support will include evaluation kit, driver source code, and reference designs

2.2 Line Interface

- Requires a single master clock (MCLK) for both E1 and T1 operation. Master clock can be 1.544MHz, 2.048MHz, 3.088MHz, 4.096MHz, 6.276MHz, 8.192MHz, 12.552MHz, or 16.384MHz.
- Fully software configurable
- Short- and long-haul applications
- Ranges include 0dB to -43dB, 0dB to -30dB, 0dB to 20dB, and 0dB to -12dB for E1; 0dB to -36dB, 0dB to 30dB, 0dB to 20dB, and 0dB to -15dB for T1
- Receiver signal level indication from -2.5dB to -36dB in T1 mode and -2.5dB to -44dB in E1 mode in 2.5dB increments
- Internal receive termination option for 75 \pm , 100 Ω , 110 Ω , and 120 Ω lines
- Monitor application gain settings of 14dB, 20dB, 26dB, and 32dB
- G.703 receive synchronization signal mode
- Flexible transmit waveform generation
- T1 DSX-1 line build-outs
- T1 CSU line build-outs of 0dB, -7.5dB, -15dB, and -22.5dB
- E1 waveforms include G.703 waveshapes for both 75 Ω coax and 120 Ω twisted cables
- Analog loss of signal detection
- AIS generation independent of loopbacks
- Alternating ones and zeros generation
- Receiver power-down
- Transmitter power-down
- Transmitter short-circuit limiter with current limit exceeded indication
- Transmit open-circuit-detected indication

2.3 Clock Synthesizer

- Output frequencies include 2.048MHz, 4.096MHz, 8.192MHz, and 16.384MHz
- Derived from user selected recovered receive clock

2.4 Jitter Attenuator

- 32-bit or 128-bit crystal-less jitter attenuator
- Requires only a 1.544MHz or 2.048MHz master clock or multiple thereof, for both E1 and T1 operation
- Can be placed in either the receive or transmit path or disabled
- Limit trip indication

2.5 Framer/Formatter

- Fully independent transmit and receive functionality
- Full receive and transmit path transparency
- T1 framing formats D4 and ESF per T1.403, and expanded SLC-96 support (TR-TSY-008).
- E1 FAS framing and CRC-4 multiframe per G.704/G.706, and G.732 CAS multiframe
- Transmit side synchronizer
- Transmit midpath CRC recalculate (E1)
- Detailed alarm and status reporting with optional interrupt support

- Large path and line error counters
 - T1:- BPV, CV, CRC6, and framing bit errors
 - E1: BPV, CV, CRC4, E-bit, and frame alignment errors
 - Timed or manual update modes
- DS1 Idle Code Generation on a per-channel basis in both transmit and receive paths
 - User defined
 - Digital Milliwatt
- ANSI T1.403-1999 Support
- G.965 V5.2 link detect
- Ability to monitor one DS0 channel in both the transmit and receive paths
- In-Band Repeating Pattern Generators and Detectors
 - Three independent Generators and Detectors
 - Patterns from 1 to 8 bits or 16 bits in Length
- Bit Oriented Code (BOC) support
- Flexible signaling support
 - Software or hardware based
 - Interrupt generated on change of signaling data
 - Optional receive signaling freeze on loss of frame, loss of signal, or frame slip
 - Hardware pins provided to indicate Loss of Frame (LOF), Loss of Signal (LOS), Loss of Transmit Clock (LOTC), or signaling freeze condition.
- Automatic RAI generation to ETS 300 011 specifications
- RAI-CI and AIS-CI support
- Expanded access to Sa and Si bits
- Option to extend carrier loss criteria to a 1ms period as per ETS 300 233
- Japanese J1 support
- Ability to calculate and check CRC6 according to the Japanese standard
- Ability to generate Yellow Alarm according to the Japanese standard
- T1 to E1 conversion

2.6 System Interface

- Independent two-frame receive and transmit elastic stores
- Independent control and clocking
- Controlled slip capability with status
- Minimum delay mode supported
- Flexible TDM backplane supports bus rates from 1.544MHz to 16.384MHz
- Supports T1 to CEPT (E1) conversion
- Programmable output clocks for fractional T1, E1, H0, and H12 applications
- Interleaving PCM bus operation
- Hardware signaling capability
- Receive signaling reinsertion to a backplane multiframe sync
- Availability of signaling in a separate PCM data stream
- Signaling freezing
- Ability to pass the T1 F-bit position through the elastic stores in the 2.048MHz backplane mode
- User-selectable synthesized clock output

2.7 HDLC Controllers

- One HDLC controller engine for each T1/E1 port
- Independent 64-byte Rx and Tx buffers with interrupt support
- Access FDL, Sa, or single DS0 channel
- Compatible with polled or interrupt driven environments

2.8 Test and Diagnostics

- IEEE 1149.1 Support
- Per-channel programmable on-chip bit error-rate testing (BERT)
- Pseudorandom patterns including QRSS
- User-defined repetitive patterns
- Daly pattern
- Error insertion single and continuous
- Total-bit and errored-bit counts
- Payload error insertion
- Error insertion in the payload portion of the T1 frame in the transmit path
- Errors can be inserted over the entire frame or selected channels
- Insertion options include continuous and absolute number with selectable insertion rates
- F-bit corruption for line testing
- Loopbacks (remote, local, analog, and per-channel loopback)

2.9 Control Port

- 8-bit parallel control port
- Intel or Motorola nonmultiplexed support
- Flexible status registers support polled, interrupt, or hybrid program environments
- Software reset supported
- Hardware reset pin
- Software access to device ID and silicon revision

3. APPLICATIONS

The DS26528 is useful in applications such as:

- Routers
- Channel Service Units (CSUs)
- Data Service Units (DSUs)
- Muxes
- Switches
- Channel Banks
- T1/E1 Test Equipment

4. SPECIFICATIONS COMPLIANCE

The DS26528 LIU meets all the latest relevant telecommunications specifications. [Table 4-1](#) provides the T1 and E1 specifications and relevant sections that are applicable to the DS26528.

Table 4-1. T1-Related Telecommunications Specifications

ANSI T1.102- Digital Hierarchy Electrical Interface.
AMI Coding.
B8ZS Substitution Definition.
DS1 Electrical Interface. Line rate +/- 32ppm; Pulse Amplitude between 2.4 to 3.6 V peak; Power Level between 12.6 to 17.9dbm; The T1 pulse mask is provided that we comply. DSX-1 for cross connects the return loss is greater than -26dB. The DSX-1 cable is restricted up to 655 feet.
This specification also provides cable characteristics of DSX-Cross Connect cable ---22 AVG cables of 1000 feet.
ANSI T1.231- Digital Hierarchy- Layer 1 in Service Performance Monitoring
BPV Error Definition; Excessive Zero Definition; LOS description; AIS definition.
ANSI T1.403- Network and Customer Installation Interface- DS1 Electrical Interface
Description of the Measurement of the T1 Characteristics—100Ω. Pulse shape and template compliance according to T1.102; Power level 12.4 to 19.7dbm when all ones is transmitted.
LBO for the Customer Interface (CI) is specified as 0dB, -7.5dB and -15dB. Line rate is +/-32 ppm. Pulse Amplitude is 2.4 to 3.6V.
AIS generation as unframed all ones is defined.
The total cable attenuation is defined as 22dB. The DS26528 will function with up to -36dB cable loss.
Note that the pulse template defined by T1.403 and T1.102 are different --- specifically at Times .61, -.27, -34 and .77. The DS26528 is complaint to both templates.
Pub 62411
This specification has tighter jitter tolerance and transfer characteristics than other specifications. The jitter transfer characteristics are tighter than G.736 and Jitter Tolerance is tighter the G.823.
(ANSI) “Digital Hierarchy – Electrical Interfaces”
(ANSI) “Digital Hierarchy – Formats Specification”
(ANSI) “Digital Hierarchy – Layer 1 In-Service Digital Transmission Performance Monitoring”
(ANSI) “Network and Customer Installation Interfaces – DS1 Electrical Interface”
(AT&T) “Requirements for Interfacing Digital Terminal Equipment to Services Employing the Extended Super frame Format”
(AT&T) “High Capacity Digital Service Channel Interface Specification”
(TTC) “Frame Structures on Primary and Secondary Hierarchical Digital Interfaces”
(TTC) “ISDN Primary Rate User-Network Interface Layer 1 Specification”

Table 4-2. E1-Related Telecommunications Specifications

ITUT G.703 Physical/Electrical Characteristics of G.703 Hierarchical Digital Interfaces
Defines the 2048Kbit/s bit rate—2048 \pm 50ppm; The transmission media are 75 Ω coax or 120 Ω twisted pair; peak to peak space voltage is \pm 0.237V; Nominal pulse width is 244 ns.
Return loss 51 to 102Hz is 6dB, 102 to 3072 Hz is 8dB, 2048 to 3072 Hz is 14dB
Nominal peak voltage is 2.37V for coax and 3V for twisted pair.
The pulse template for E1 is defined in G.703.
ITUT G.736 Characteristics of Synchronous Digital Multiplex Equipment operating at 2048Kbit/s
The peak to peak jitter at 2048Kbit/s has to be less than 0.05 UI at 20 to 100Hz.
Jitter transfer between 2.048 synchronization signal and 2.048 transmission signal is provided.
ITUT G.742 Second Order Digital Multiplex Equipment Operating at 8448Kbit/s
The DS26528 jitter attenuator is complaint with Jitter transfer curve for sinusoidal jitter input.
ITUT G.772
This specification provides the method for using receiver for transceiver 0 as a monitor for the rest of the 7 transmitter/receiver combinations.
ITUT G.775
A LOS detection criterion is defined.
ITUT G.823 The control of jitter and wander within digital networks which are based on 2.048Kbit/s hierarchy
G.823 provides the jitter amplitude tolerance at different frequencies, specifically 20Hz, 2.4kHz, 18kHz, and 100kHz.
ETSI 300 233
This specification provides LOS and AIS signal criteria for E1 mode
Pub 62411
This specification has tighter jitter tolerance and transfer characteristics than other specifications.
The jitter transfer characteristics are tighter than G.736 and Jitter Tolerance is tighter then G.823.
(ITU) "Synchronous Frame Structures used at 1544, 6312, 2048, 8488 and 44736Kbit/s Hierarchical Levels"
(ITU) "Frame Alignment and Cyclic Redundancy Check (CRC) Procedures Relating to Basic Frame Structures Defined in Recommendation G.704"
(ITU) "Characteristics of primary PCM Multiplex Equipment Operating at 2048Kbit/s"
(ITU) Characteristics of a synchronous digital multiplex equipment operating at 2048Kbit/s"
(ITU) "Loss Of Signal (LOS) and Alarm Indication Signal (AIS) Defect Detection and Clearance Criteria"
(ITU) "The Control of Jitter and Wander Within Digital Networks Which are Based on the 2048Kbit/s Hierarchy"
(ITU) "Primary Rate User-Network Interface – Layer 1 Specification"
(ITU) "Error Performance Measuring Equipment Operating at the Primary Rate and Above"
(ITU) "In-service code violation monitors for digital systems"
(ETSI) "Integrated Services Digital Network (ISDN); Primary rate User-Network Interface (UNI); Part 1/ Layer 1 specification"
(ETSI) "Transmission and multiplexing; Physical/electrical characteristics of hierarchical digital interfaces for equipment using the 2048Kbit/s-based plesiochronous or synchronous digital hierarchies"
(ETSI) "Integrated Services Digital Network (ISDN); Access digital section for ISDN primary rate"
(ETSI) "Integrated Services Digital Network (ISDN); Attachment requirements for terminal equipment to connect to an ISDN using ISDN primary rate access"
(ETSI) "Business Telecommunications (BT); Open Network Provision (ONP) technical requirements; 2048 Kbit/s digital unstructured leased lines (D2048U) attachment requirements for terminal equipment interface"
(ETSI) "Business Telecommunications (BTC); 2048 Kbit/s digital structured leased lines (D2048S); Attachment requirements for terminal equipment interface"
(ITU) "Synchronous Frame Structures used at 1544, 6312, 2048, 8488 and 44736Kbit/s Hierarchical Levels"
(ITU) "Frame Alignment and Cyclic Redundancy Check (CRC) Procedures Relating to Basic Frame Structures Defined in Recommendation G.704"

5. ACRONYMS AND GLOSSARY

This data sheet assumes a particular nomenclature of the T1 and E1 operating environment. In each 125 μ s T1 frame, there are 24 8-bit channels plus a framing bit. It is assumed that the framing bit is sent first followed by channel 1. For T1 and E1 each channel is made up of 8 bits, which are numbered 1 to 8. Bit 1, the MSB, is transmitted first. Bit 8, the LSB, is transmitted last.

Locked refers to two clock signals that are phase- or frequency-locked or derived from a common clock (i.e., a 1.544MHz clock can be locked to a 2.048MHz clock if they share the same 8kHz component).

TIME SLOT NUMBERING SCHEMES

TS	0	1	2	3	4	5	6	7	8	9	10	11	12	13	14	15	16	17	18	19	20	21	22	23	24	25	26	27	28	29	30	31
Channel	1	2	3	4	5	6	7	8	9	10	11	12	13	14	15	16	17	18	19	20	21	22	23	24	25	26	27	28	29	30	31	32
Phone Channel		1	2	3	4	5	6	7	8	9	10	11	12	13	14	15	16	17	18	19	20	21	22	23	24	25	26	27	28	29	30	

6. MAJOR OPERATING MODES

The DS26528 has two major modes of operation: T1 mode and E1 mode. The mode of operation for each LIU is configured in the [LTRCR](#) register. The mode of operation for each framer is configured in the [TMMR](#) register. J1 operation is a special case of T1 operating mode.

7. BLOCK DIAGRAMS

Figure 7-1. Block Diagram

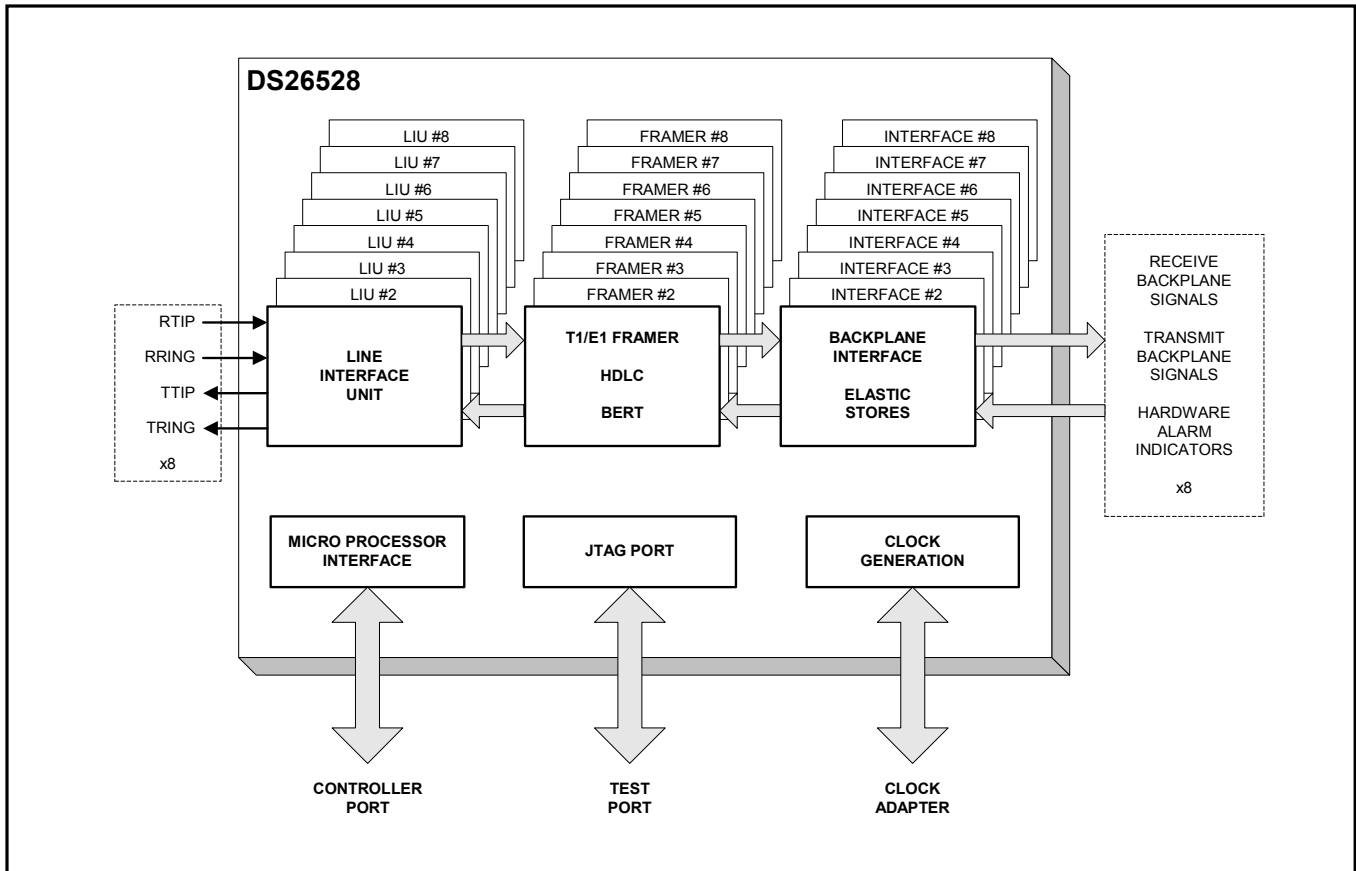
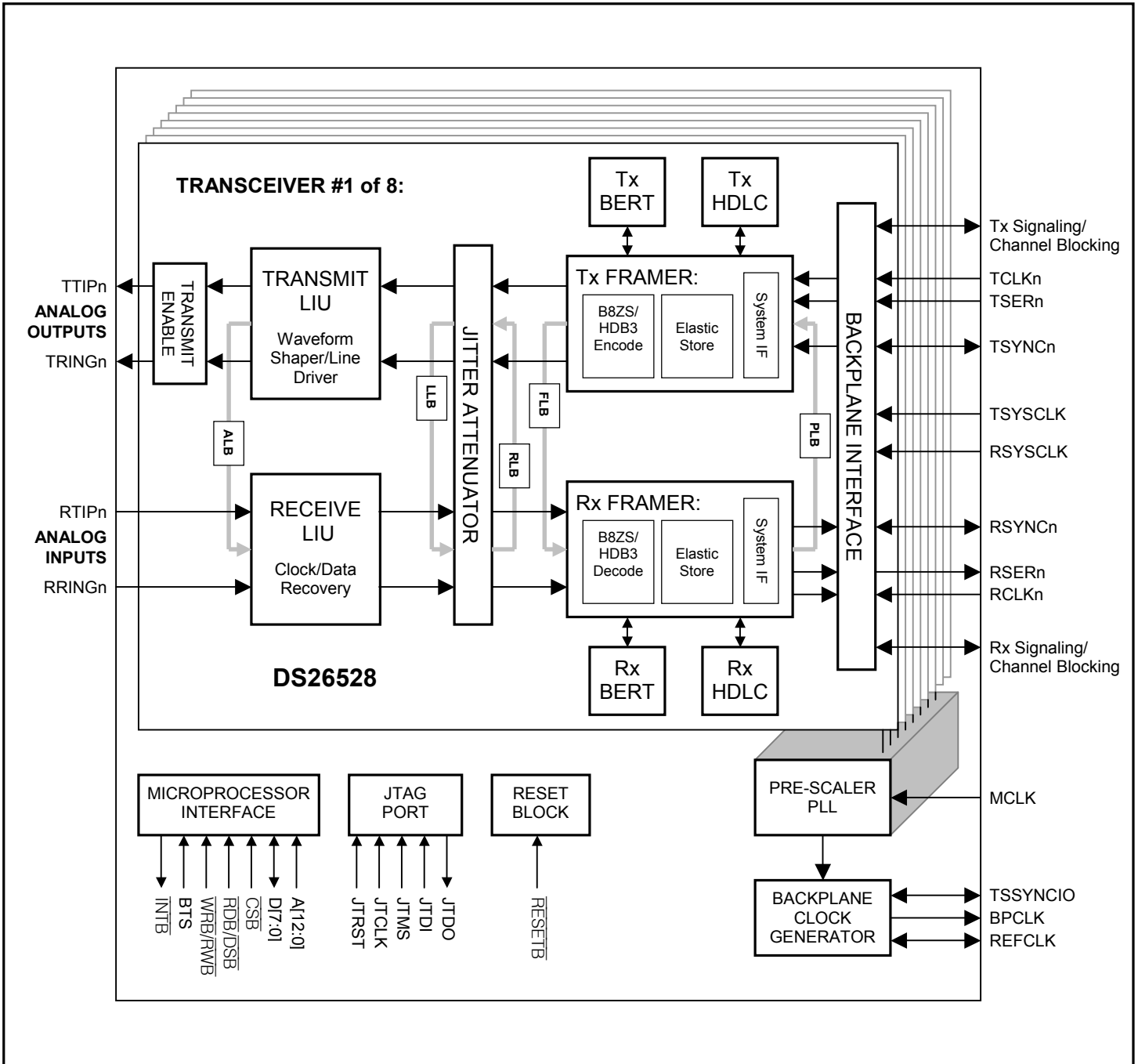


Figure 7-2. Detailed Block Diagram



8. PIN DESCRIPTIONS

8.1 Pin Functional Description

Table 8-1. Detailed Pin Descriptions

NAME	PIN	TYPE	DESCRIPTION
ANALOG TRANSMIT			
TTIP1	A1, A2	Analog Output High-Z	<p>Transmit Bipolar Tip for Transceiver 1 to 8. These pins are differential line driver tip outputs. These pins can be High-Z if:</p> <p>If pin TXENABLE is low the TTIP/TRING will be High-Z. Note that if TXENABLE is low, the register settings for control of the TTIP/TRING are ignored and output is High-Z.</p> <p>The differential outputs of TTIPn and TRINGn can provide internal matched impedance for E1 75Ω, E1 120Ω, T1 100Ω, or J1 110Ω. The user has the option of turning off internal termination.</p>
TTIP2	H1, H2		
TTIP3	J1, J2		
TTIP4	T1, T2		
TTIP5	T15, T16		
TTIP6	J15, J16		
TTIP7	H15, H16		
TTIP8	A15, A16		
TRING1	A3, B3	Analog Output High-Z	<p>Transmit Bipolar Ring for Transceiver 1 to 8. These pins are differential line driver ring outputs. These pins can be High-Z if:</p> <p>If pin TXENABLE is low the TTIP/TRING will be High-Z. Note that if TXENABLE is low, the register settings for control of the TTIP/TRING are ignored and output is High-Z.</p> <p>The differential outputs of TTIPn and TRINGn can provide internal matched impedance for E1 75Ω, E1 120Ω, T1 100Ω, or J1 110Ω. The user has the option of turning off internal termination.</p>
TRING2	G3, H3		
TRING3	J3, K3		
TRING4	R3, T3		
TRING5	R14, T14		
TRING6	J14, K14		
TRING7	G14, H14		
TRING8	A14, B14		
TXENABLE	L13	I	<p>Transmit Enable. If this pin is pulled low, all the transmitter outputs (TTIP and TRING) are High-Z. The register settings for tri-state control of TTIP/TRING are ignored if TXEnable is low. If TXEnable is high, the particular driver can be tri-stated by the register settings.</p>
ANALOG RECEIVE			
RTIP1	C1	Analog Input	<p>Receive Bipolar Tip for Transceiver 1 to 8. The differential inputs of RTIPn and RRINGn can provide internal matched impedance for E1 75Ω, E1 120Ω, T1 100Ω, or J1 110Ω. The user has the option of turning off internal termination via the LIU receive impedance and sensitivity monitor Register.</p>
RTIP2	F1		
RTIP3	L1		
RTIP4	P1		
RTIP5	P16		
RTIP6	L16		
RTIP7	F16		
RTIP8	C16		
RRING1	C2	Analog Input	<p>Receive Bipolar Ring for Transceiver 1 to 8. The differential inputs of RTIPn and RRINGn can provide internal matched impedance for E1 75Ω, E1 120Ω, T1 100Ω, or J1 110Ω. The user has the option of turning off internal termination via the LIU receive impedance and sensitivity monitor register.</p>
RRING2	F2		
RRING3	L2		
RRING4	P2		
RRING5	P15		
RRING6	L15		
RRING7	F15		
RRING8	C15		
TRANSMIT FRAMER			
TSER1	F6	I	<p>Transmit NRZ Serial Data. Sampled on the falling edge of TCLK when the transmit side elastic store is disabled. Sampled on the falling edge of TSYSCLOCK when the transmit side elastic store is enabled.</p> <p>In IBO Mode, data for multiple framers can be used in High Speed Multiplexed Scheme. This is described in Section 9.8.2. The table there presents the combination of framer data for each of the streams.</p> <p>TSYSCLOCK is used as a reference when IBO is invoked. See Table 9-7.</p>
TSER2	E7		
TSER3	R4		
TSER4	N7		
TSER5	M10		
TSER6	L11		
TSER7	F10		
TSER8	D12		
TCLK1	C5	I	<p>Transmit Clock. A 1.544 MHz or a 2.048MHz primary clock. Used to clock data through the transmit side of the transceiver. TSER data is sampled on the falling edge of TCLK. TCLK is used to sample TSER when the elastic store is not enabled or IBO is not used.</p>
TCLK2	D7		
TCLK3	P5		
TCLK4	L8		
TCLK5	L10		
TCLK6	N11		
TCLK7	E10		
TCLK8	B13		

NAME	PIN	TYPE	DESCRIPTION
TSYSCLK	P13	I	Transmit System Clock. 1.544MHz, 2.048MHz, 4.096MHz, 8.192MHz, or 16.384MHz clock. Only used when the transmit-side elastic store function is enabled. Should be tied low in applications that do not use the transmit side elastic store. This is a common clock that is used for all 8 transmitters. The clock can be 4.096MHz, 8.912MHz, or 16.384MHz when IBO mode is used.
TSYNC1	B4	IO	Transmit Synchronization. A pulse at this pin establishes either frame or multiframe boundaries for the transmit side. This signal can also be programmed to output either a frame or multiframe pulse. If this pin is set to output pulses at frame boundaries, it can also be set to output double-wide pulses at signaling frames in T1 mode. The operation of this signal is synchronous with TCLK.
TSYNC2	F7		
TSYNC3	M6		
TSYNC4	M7		
TSYNC5	N10		
TSYNC6	T12		
TSYNC7	B11		
TSYNC8	A13		
TSSYNCIO	N13	I/O	Transmit System Synchronization In. Only used when the transmit-side elastic store is enabled. A pulse at this pin will establish either frame or multiframe boundaries for the transmit side. Note that if the elastic store is enabled, frame or multiframe boundary will be established for all 8 transmitters. Should be tied low in applications that do not use the transmit side elastic store. The operation of this signal is synchronous with TSYSCLK. Transmit System Synchronization Out. If configured as an output, an 8kHz pulse synchronous to the BPCLK will be generated. This pulse in combination with Bpclk can be used as an IBO Master. The BPCLK can be sourced to RSYCLK and TSYSCLK and TSSYNCIO as a source to RSYNC and TSSYNCIO of DS26528 or RSYNC and TSSYNC of other Dallas Semiconductor Parts.
TSIG1	D5	I	Transmit Signaling. When enabled, this input samples signaling bits for insertion into outgoing PCM data stream. Sampled on the falling edge of TCLK when the transmit-side elastic store is disabled. Sampled on the falling edge of TSYSCLK when the transmit-side elastic store is enabled. In IBO mode, the TSIG streams can run up to 16.384MHz. See Table 9-8 .
TSIG2	A6		
TSIG3	T4		
TSIG4	R6		
TSIG5	T10		
TSIG6	R12		
TSIG7	A11		
TSIG8	C13		
TCHBLK/CLK1	A5	O	Transmit Channel Block or Transmit Channel Block Clock. A dual function pin. TCHBLK is a user programmable output that can be forced high or low during any of the channels. Synchronous with TCLK when the transmit side elastic store is disabled. Synchronous with TSYSCLK when the transmit side elastic store is enabled. Useful for blocking clocks to a serial UART or LAPD controller in applications where not all channels are used such as Fractional T1, Fractional E1, 384 KBPS (H0), 768 KBPS or ISDN-PRI. Also useful for locating individual channels in drop-and-insert applications, for external per-channel loopback, and for per-channel conditioning. TCHCLK. TCHCLK is a 192kHz (T1) or 256kHz (E1) clock that pulses high during the LSB of each channel. It can also be programmed to output a gated transmit bit clock controlled by TCHBLK. It is synchronous with TCLK when the transmit-side elastic store is disabled. It is synchronous with TSYSCLK when the transmit-side elastic store is enabled. Useful for parallel-to-serial conversion of channel data.
TCHBLK/CLK2	C7		
TCHBLK/CLK3	L7		
TCHBLK/CLK4	P7		
TCHBLK/CLK5	P9		
TCHBLK/CLK6	P11		
TCHBLK/CLK7	D10		
TCHBLK/CLK8	E11		
RECEIVE FRAMER			
RSER1	E5	O	Received Serial Data. Received NRZ serial data. Updated on rising edges of RCLK when the receive side elastic store is disabled. Updated on the rising edges of RSYCLK when the receive side elastic store is enabled. When IBO mode is used, the RSER pins can output data for multiple framers. The RSER data is synchronous to RSYCLK. This is described in Section 9.8.2 or see Table 9-5 .
RSER2	D6		
RSER3	N4		
RSER4	N6		
RSER5	M11		
RSER6	M12		
RSER7	B12		
RSER8	F11		
RCLK1	F4	O	Receive Clock. A 1.544MHz (T1) or 2.048MHz (E1) clock that is used to clock data through the receive-side framer. This clock is recovered from the signal at RTIP and RRING. RSER data is output on the rising edge of RCLK. RCLK is used to output RSER when the elastic store is not enabled or IBO is not used. When the elastic store is enabled or IBO is used the RSER is clocked by RSYCLK.
RCLK2	G4		
RCLK3	L4		
RCLK4	M4		
RCLK5	K13		
RCLK6	J13		
RCLK7	F13		
RCLK8	E13		

NAME	PIN	TYPE	DESCRIPTION
RSYSCLK	L12	I	Receive System Clock. 1.544MHz, 2.048MHz, 4.096MHz, or 8.192MHz or 16.384MHz receive backplane clock. Only used when the receive side elastic store function is enabled. Should be tied low in applications that do not use the receive side elastic store. Multiple of 2.048MHz is expected when the IBO Mode is used. Note that RSYSCLK is used for all 8 transceivers.
RSYNC1	A4	I/O	Receive Synchronization. If the receive side elastic store is enabled, then this signal is used to input a frame or multiframe boundary pulse if set to output frame boundaries then RSYNC can be programmed to output double-wide pulses on signaling frames in T1 mode. In E1 Mode RSYNC out can be used to indicate CAS and CRC4 Multiframe. The DS26528 also has the facility to accept H.100 compatible synchronization signal.
RSYNC2	B6		
RSYNC3	N5		
RSYNC4	T6		
RSYNC5	R10		
RSYNC6	P12		
RSYNC7	C11		
RSYNC8	D13		
RM/RFSYNC1	C4	O	Receive Multiframe or Frame Synchronization. A dual function pin to indicate Frame or Multiframe Synchronization. RFSYNC is an extracted 8 kHz pulse, one RCLK wide that identifies frame boundaries. RMSYNC is an extracted pulse, one RCLK wide (elastic store disabled) or one RSYSCLK wide (elastic store enabled), which identifies multiframe boundaries. When the receive elastic store is enabled, the RMSYNC signal indicates the multiframe sync on the system (backplane) side of the Elastic Store. In E1 mode, will indicate either the CRC4 or CAS multiframe as determined by the RSMS2 control bit in RIOCR.1 Register.
RM/RFSYNC2	C6		
RM/RFSYNC3	P4		
RM/RFSYNC4	P6		
RM/RFSYNC5	P10		
RM/RFSYNC6	N12		
RM/RFSYNC7	D11		
RM/RFSYNC8	E12		
RSIG1	D4	O	Receive Signaling. Outputs signaling bits in a PCM format. Updated on rising edges of RCLK when the receive side elastic store is disabled. Updated on the rising edges of RSYSCLK when the receive side elastic store is enabled. See Table 9-6 .
RSIG2	E6		
RSIG3	M5		
RSIG4	R5		
RSIG5	R11		
RSIG6	R13		
RSIG7	A12		
RSIG8	F12		
AL/RSIG/ FLOS1	C3	O	Analog Loss or Receive Signaling Freeze or Framer LOS. Analog LOS reflects the LOS (Loss of Signal) detected by the LIU front end and Framer LOS is LOS detection by the corresponding framer; the same pins can reflect Receive Signaling Freeze indications. This selection can be made by settings in Global Transceiver Control Register. If Framer LOS is selected, this pin can be programmed to toggle high when the framer detects a loss of signal condition, or when the signaling data is frozen via either automatic or manual intervention. The indication is used to alert downstream equipment of the condition.
AL/RSIG/ FLOS2	F3		
AL/RSIG/ FLOS3	L3		
AL/RSIG/ FLOS4	P3		
AL/RSIG/ FLOS5	P14		
AL/RSIG/ FLOS6	L14		
AL/RSIG/ FLOS7	F14		
AL/RSIG/ FLOS8	C14		
RLF/LTC1	D3	O	Receive Loss of Frame or Loss of Transmit Clock. This pin can also be programmed to either toggle high when the synchronizer is searching for the frame and multiframe or to toggle high if the TCLK pin has not been toggled for approximately three clock periods.
RLF/LTC2	E3		
RLF/LTC3	M3		
RLF/LTC4	N3		
RLF/LTC5	N14		
RLF/LTC6	M14		
RLF/LTC7	E14		
RLF/LTC8	D14		

NAME	PIN	TYPE	DESCRIPTION
RCHBLK/CLK1	E4	O	<p>Receive Channel Block or Receive Channel Block Clock. Pin can be configured to output either RCHBLK or RCHCLK. RCHBLK is a user-programmable output that can be forced high or low during any of the 24 T1 or 32 E1 channels. Synchronous with RCLK when the receive side elastic store is disabled. Synchronous with RSYSCLK when the receive-side elastic store is enabled. Useful for blocking clocks to a serial UART or LAPD controller in applications where not all channels are used such as fractional service, 384kbps service, 768kbps, or ISDN–PRI. Also useful for locating individual channels in drop-and-insert applications, for external per-channel loopback, and for per-channel conditioning.</p> <p>RCHCLK is a 192 kHz (T1) or 256kHz (E1) clock that pulses high during the LSB of each channel. Synchronous with RCLK when the receive-side elastic store is disabled. Synchronous with RSYSCLK when the receive-side elastic store is enabled. Useful for parallel-to-serial conversion of channel data.</p>
RCHBLK/CLK2	B5		
RCHBLK/CLK3	L6		
RCHBLK/CLK4	T5		
RCHBLK/CLK5	T11		
RCHBLK/CLK6	T13		
RCHBLK/CLK7	C12		
RCHBLK/CLK8	G13		
BPCLK	E8	O	<p>Backplane Clock. Programmable clock output that can be set to 2.048MHz, 4.096MHz, 8.192MHz, or 16.384MHz. The reference for this clock can be RCLK from any of the LIU, 1.544MHz or 2.048MHz frequency derived from MCLK or an external reference clock. This allows for the IBO clock to reference from external source or T1J1E1 recovered clock or the MCLK oscillator.</p>
MICROPROCESSOR INTERFACE			
A12	C8	I	<p>Address12 to Address0. This bus selects a specific register in the DS26528 during read/write access. A12 is the MSB and A0 is the LSB.</p>
A11	A8		
A10	B8		
A9	F8		
A8	B9		
A7	A9		
A6	C9		
A5	D9		
A4	E9		
A3	F9		
A2	B10		
A1	A10		
A0	C10		
D7	T9	I/O	<p>Data7 to Data0. This 8-bit, bidirectional data bus is used for read/write access of the DS26528 information and control registers. D7 is the MSB and D0 is the LSB.</p>
D6	N9		
D5	M9		
D4	R8		
D3	T8		
D2	P8		
D1	L9		
D0	N8		
$\overline{\text{CSB}}$	T7	I	<p>Chip Select Bar. This active-low signal is used to qualify register read/write accesses. The $\overline{\text{RDDSb}}$ and $\overline{\text{WRB}}$ signals are qualified with $\overline{\text{CSB}}$.</p>
$\overline{\text{RDB/DSB}}$	M8	I	<p>Read Bar Data or Strobe Bar. This active-low signal along with $\overline{\text{CSB}}$ qualifies read access to one of the DS26528 registers. The DS26528 drives the data bus with the contents of the addressed register while $\overline{\text{RDB}}$ and $\overline{\text{CSB}}$ are both low.</p>
$\overline{\text{WRB/RWB}}$	R7	I	<p>Write Bar/Read-Write Bar. This active-low signal along with $\overline{\text{CSB}}$ qualifies write access to one of the DS26528 registers. Data at D[7/0] is written into the addressed register at the rising edge of $\overline{\text{WRB}}$ while $\overline{\text{CSB}}$ is low.</p>
$\overline{\text{INTB}}$	R9	U	<p>Interrupt Bar. This active-low, open-drain output is asserted when an unmasked interrupt event is detected. $\overline{\text{INTB}}$ will be deasserted when all interrupts have been acknowledged and serviced. Extensive Mask bits are provided at the global level, framer, LIU, and BERT level.</p>
BTS	M13	I	<p>Bus Type Select. Set high to select Motorola bus timing, low to select Intel bus timing. This pin controls the function of the $\overline{\text{RDDSb}}$, and $\overline{\text{WRB}}$ pins.</p>
SYSTEM INTERFACE			
MCLK	B7	I	<p>Master Clock. This is an independent free-running clock whose input can be a multiple of 2.048MHz ± 50ppm or 1.544MHz ± 50ppm. The clock selection is available by bits MPS0 and MPS1 and FREQSEL. Multiple of 2.048MHz can be internally adapted to 1.544MHz. Multiple of 1.544MHz can be adapted to 2.048MHz. Note that TCLK has to be 2.048MHz for E1 and 1.544MHz for T1/J1 operation. See Table 10-11.</p>

NAME	PIN	TYPE	DESCRIPTION
$\overline{\text{RESETB}}$	J12	I	Reset Bar. Active-low reset. This input forces the complete DS26528 reset. This includes reset of the registers, framers, and LIUs.
REFCLKIO	A7	I/O	Reference Clock Input/Output Input: A 2.048MHz or 1.544MHz clock input. This clock can be used to generate the backplane clock. This allows for the users to synchronize the system backplane with the reference clock. The other options for the backplane clock reference are LIU-received clocks or MCLK. Output: This signal can also be used to output a 1.544MHz or 2.048MHz reference clock. This allows for multiple DS26528 to share the same reference for generation of the backplane clock. Hence, in a system consisting of multiple DS26528s, one can be a master and others a slave using the same Reference Clock.
TEST			
DIGIOEN	D8	I Pullup	Digital Enable. When this pin and JTRST are pulled low all Digital I/O pins are placed in a high-impedance state. If this pin is High the Digital I/O pins operate normally. This pin has to be connected to V_{DD} for normal operation.
JTRST	L5	I Pullup	JTAG Reset. JTRST is used to asynchronously reset the test access port controller. After power up, JTRST must be toggled from low to high. This action will set the device into the JTAG DEVICE ID mode. Pulling JTRST low restores normal device operation. JTRST is pulled HIGH internally via a 10k Ω resistor operation. If boundary scan is not used, this pin should be held low.
JTMS	K4	I Pullup	JTAG Mode Select. This pin is sampled on the rising edge of JTCLK and is used to place the test access port into the various defined IEEE 1149.1 states. This pin has a 10k pull up resistor.
JTCLK	F5	I	JTAG Clock. This signal is used to shift data into JTDI on the rising edge and out of JTDO on the falling edge.
JTDI	H4	I Pullup	JTAG Data In. Test instructions and data are clocked into this pin on the rising edge of JTCLK. This pin has a 10k Ω pullup resistor.
JTDO	J4	O High-Z	JTAG Data Out. Test instructions and data are clocked out of this pin on the falling edge of JTCLK. If not used, this pin should be left unconnected.
POWER SUPPLIES			
ATVDD	B1, B16, G1, G16, K1, K16, R1, R16	—	3.3V Analog Transmit Power Supply. These V_{DD} inputs are used for the transmit LIU sections of the DS26528.
ATVSS	B2, B15, G2, G15, K2, K15, R2, R15	—	Analog Transmit V_{SS}. These pins are used for transmit analog V_{SS} .
ARVDD	D1, D16, E1, E16, M1, M16, N1, N16	—	3.3 V Analog Receive Power Supply. This V_{DD} inputs are used for the Receive LIU sections of the DS26528.
ARVSS	D2, D15, E2, E15, M2, M15, N2, N15	—	Analog Receive V_{SS}. These pins are used for analog V_{SS} for the receivers.
ACVDD	H7	—	Analog Clock Conversion V_{DD}. This V_{DD} inputs are used for the clock conversion unit of the DS26528.
ACVSS	J7	—	Analog Clock V_{SS}. This pin is used for clock converter analog V_{SS} .
DVDD	G5–G12, H8, H9	—	3.3V Power Supply for Digital Framers
DVDDIO	H5, H6, H10, H11	—	3.3V Power Supply for I/Os
DVSS	H12, H13, J8, J9, K5– K12	—	Digital Ground for the Framers
DVSSIO	J5, J6, J10, J11	—	Digital Ground for the I/Os

Figure 8-1. BGA Pinout

	1	2	3	4	5	6	7	8	9	10	11	12	13	14	15	16	
A	TTIP1	TTIP1	TRING1	RSYNC1	TCHBLK1	TSIG2	REFCLKIO	A11	A7	A1	TSIG7	RSIG7	TSYNC8	TRING8	TTIP8	TTIP8	
B	ATVDD	ATVSS	TRING1	TSYNC1	RCHBLK2	RSYNC2	MCLK	A10	A8	A2	TSYNC7	RSER7	TCLK8	TRING8	ATVSS	ATVDD	
C	RTIP1	RRING1	ALRSIGF1	RMRFSYNC1	TCLK1	RMRFSYNC2	TCHBLK2	A12	A6	A0	RSYNC7	RCHBLK7	TSIG8	ALRSIGF8	RRING8	RTIP8	
D	ARVDD	ARVSS	RLFLTC1	RSIG1	TSIG1	RSER2	TCLK2	DIGIOEN	A5	TCHBLK7	RMRFSYNC7	TSER8	RSYNC8	RLFLTC8	ARVSS	ARVDD	
E	ARVDD	ARVSS	RLFLTC2	RCHBLK1	RSER1	RSIG2	TSER2	BCLK	A4	TCLK7	TCHBLK8	RMFSYC8	RCLK8	RLFLTC7	ARVSS	ARVDD	
F	RTIP2	RRING2	ALRSIGF2	RCLK1	JTCLK	TSER1	TSYNC2	A9	A3	TSER7	RSER8	RSIG8	RCLK7	ALRSIGF7	RRING7	RTIP7	
G	ATVDD	ATVSS	TRING2	RCLK2	DVDD	DVDD	DVDD	DVDD	DVDD	DVDD	DVDD	DVDD	DVDD	RCHBLK8	TRING7	ATVSS	ATVDD
H	TTIP2	TTIP2	TRING2	JTDI	DVDDIO	DVDDIO	ACVDD	DVDD	DVDD	DVDDIO	DVDDIO	DVSS	DVSS	TRING7	TTIP7	TTIP7	
J	TTIP3	TTIP3	TRING3	JTDO	DVSSIO	DVSSIO	ACVSS	DVSS	DVSS	DVSSIO	DVSSIO	$\overline{\text{RESETB}}$	RCLK6	TRING6	TTIP6	TTIP6	
K	ATVDD	ATVSS	TRING3	JTMS	DVSS	DVSS	DVSS	DVSS	DVSS	DVSS	DVSS	DVSS	RCLK5	TRING6	ATVSS	ATVDD	
L	RTIP3	RRING3	ALRSIGF3	RCLK3	JTRST	RCHBLK3	TCHBLK3	TCLK4	D1	TCLK5	TSER6	RSYSCLK	TXENABLE	ALRSIGF6	RRING6	RTIP6	
M	ARVDD	ARVSS	RLFLTC3	RCLK4	RSIG3	TSYNC3	TSYNC4	$\overline{\text{RDB/DSB}}$	D5	TSER5	RSER5	RSER6	BTS	RLFLTC6	ARVSS	ARVDD	
N	ARVDD	ARVSS	RLFLTC4	RSER3	RSYNC3	RSER4	TSER4	D0	D6	TSYNC5	TCLK6	RMRFSYNC6	TSSYNCIO	RLFLTC5	ARVSS	ARVDD	
P	RTIP4	RRING4	ALRSIGF4	RMRFSYNC3	TCLK3	RMRFSYNC4	TCHBLK4	D2	TCHBLK5	RMRFSYNC5	TCHBLK6	RSYNC6	TSYSCLK	ALRSIGF5	RRING5	RTIP5	
R	ATVDD	ATVSS	TRING4	TSER3	RSIG4	TSIG4	$\overline{\text{WRB/RWB}}$	D4	$\overline{\text{INTB}}$	RSYNC5	RSIG5	TSIG6	RSIG6	TRING5	ATVSS	ATVDD	
T	TTIP4	TTIP4	TRING4	TSIG3	RCHBLK4	RSYNC4	$\overline{\text{CSB}}$	D3	D7	TSIG5	RCHBLK5	TSYNC6	RCHBLK6	TRING5	TTIP5	TTIP5	

9. FUNCTIONAL DESCRIPTION

9.1 Processor Interface

Microprocessor control of the DS26528 is accomplished through the 28 hardware pins of the microprocessor port. The 8-bit parallel data bus can be configured for Intel or Motorola modes of operation with the Bus Type Select (BTS) pin. When the BTS pin is a logic 0, bus timing is in Intel mode, as shown in [Figure 13-1](#) and [Figure 13-2](#). When the BTS pin is a logic 1, bus timing is in Motorola mode, as shown in [Figure 13-3](#) and [Figure 13-4](#). The address space is mapped through the use of 13 address lines, A0–A12. Multiplexed Mode is not supported on the processor interface.

The Chip Select Bar ($\overline{\text{CSB}}$) pin must be brought to a logic low level to gain read and write access to the microprocessor port. With Intel timing selected, the Read Bar ($\overline{\text{RDB}}$) and Write Bar ($\overline{\text{WRB}}$) pins are used to indicate read and write operations and latch data data through the interface. With Motorola timing selected, the Read-Write Bar ($\overline{\text{RWB}}$) pin is used to indicate read and write operations while the Data Strobe Bar ($\overline{\text{DSB}}$) pin is used to latch data through the interface.

The interrupt output pin ($\overline{\text{INTB}}$) is an open-drain output that will assert a logic-low level upon a number of software maskable interrupt conditions. This pin is normally connected to the microprocessor interrupt input.

The device has a bulk write mode that allows a microprocessor to write all eight internal transceivers with each bus write cycle. By setting the BWE bit ([GTCCR1.2](#)), each port write cycle will write to all eight framers, LIUs, or BERTs at the same time. The BWE bit must be cleared before normal write operation is resumed. This function is useful for device initialization.

The register map is shown in [Figure 10-1](#).

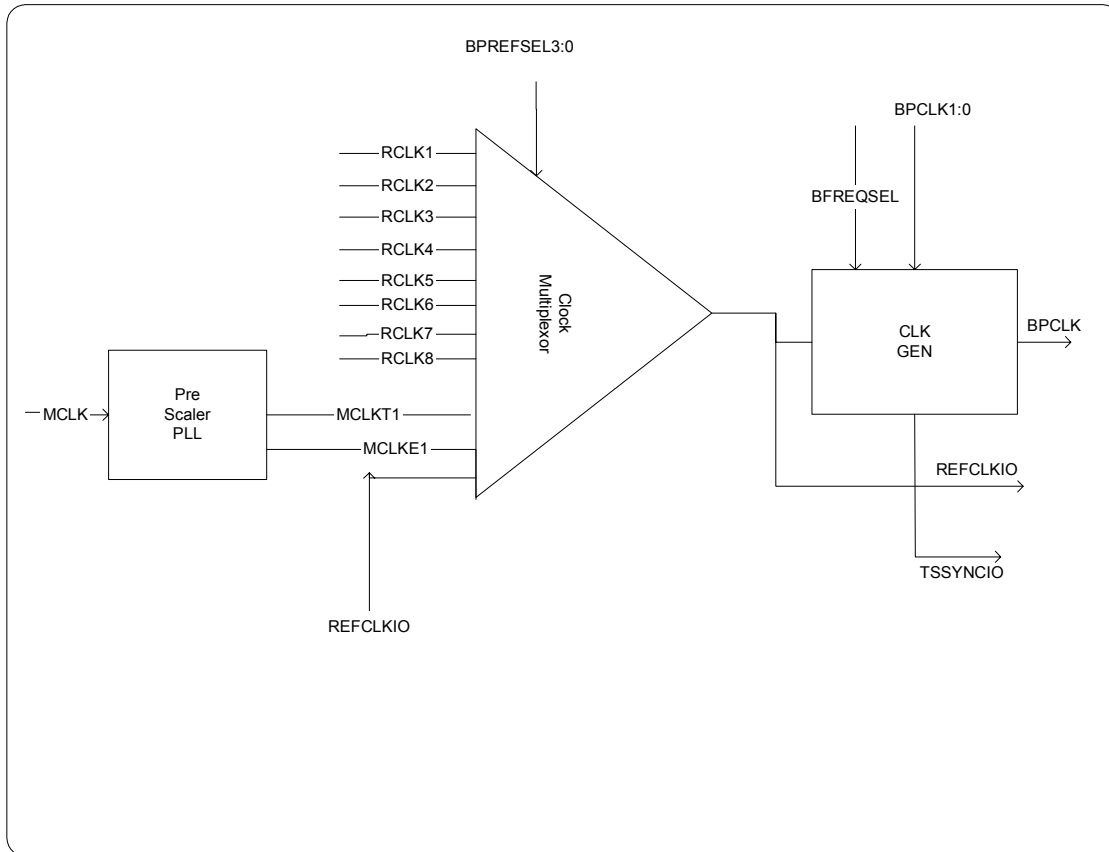
9.2 Clock Structure

The user should provide a system clock to the MCLK input of 2.048MHz, 1.544MHz, or a multiple of up to 8x the T1 and E1 frequencies. To meet many specifications, the MCLK source should have ± 50 ppm accuracy.

9.2.1.1 Backplane Clock Generation

The DS26528 provides facility for provision of BPCLK at 2.048MHz, 4.096MHz, 8.192MHz, 16.384MHz (see [Figure 9-1](#)). The Global Transceiver Control Register ([GTCCR](#)) is used to control the backplane clock generation. This register is also used to program REFCLKIO as an input or output. REFCLKIO can be an output sourcing MCLKT1 or MCLKE1 as shown in [Figure 9-1](#).

This backplane clock and frame pulse (TSSYNCIO) can be used by the DS26528 and other IBO equipped devices as an “IBO Bus Master.” Hence the DS26528 will provide the 8 KHZ Sync Pulse and 4,8,16MHz clock. This can be used by the link layer devices and frames connected to the IBO Bus.

Figure 9-1. Backplane Clock Generation

The reference clock for the Backplane Clock generator can be:

- External Master Clock. A pre-scaler can be used to generate T1 or E1 Frequency
- External Reference Clock REFCLKIO. This allows for multiple DS26528 to use the Backplane Clock from a common reference.
- Internal LIU recovered RCLKs 1 to 8.
- The Clock Generator can be used to generate BCLK of 2.048MHz, 4.096MHz, 8.192MHz, 16.384MHz for the IBO.
- If MCLK or RCLKs are used as a reference, REFCLKIO can be used to provide a 2.048MHz or 1.544MHz clock for external use.

9.3 Resets and Power-Down Modes

A hardware reset is issued by forcing the $\overline{\text{RESETB}}$ pin to logic low. The $\overline{\text{RESETB}}$ input pin resets all framers, LIUs, and BERTs. Note that not all registers are cleared to 00h on a reset condition. **The register space must be reinitialized to appropriate values after a hardware or software reset has occurred.** This includes writing reserved locations to 00h.

Table 9-1. Reset Functions

RESET FUNCTION	LOCATION	COMMENTS
Hardware Device Reset	RESETB Pin	Transition to a logic 0 level resets the DS26528.
Hardware JTAG Reset	JTRST Pin	Resets the JTAG test port.
Global Framer and BERT Resets	GFSRR .0 - .7	Writing to these bits resets the associated Framer and BERT (transmit & receive).
Global LIU Resets	GLSRR .0 - .7	Writing to these bits resets the associated Line Interface Unit.
Framer Receive Reset	RMMR .1	Writing to this bit resets the Receive Framer.
Framer Transmit Reset	TMMR .1	Writing to this bit resets the Transmit Framer.
HDLC Receive Reset	RHC .6	Writing to this bit resets the Receive HDLC controller.
HDLC Transmit Reset	THC 1.5	Writing to this bit resets the Transmit HDLC controller.
Elastic Store Receive Reset	RESCR .2	Writing to this bit resets the Receive Elastic Store.
Elastic Store Transmit Reset	TESCR .2	Writing to this bit resets the Transmit Elastic Store.
Bit Oriented Code Receive Reset	T1RBOCC .7	Writing to this bit resets the Receive BOC controller.
Loop Code Integration Reset	T1RDNCD 1, T1RUPCD 1	Writing to these registers resets the programmable in-band code integration period.
Spare Code Integration Reset	T1RSCD 1	Writing to this register resets the programmable in-band code integration period.

The DS26528 has several features included to reduce power consumption. The individual LIU transmitters can be powered down by setting the TPDE bit in the LIU maintenance control register ([LMCR](#)). Note that powering down the transmit LIU results in a High-Z state for the corresponding TTIP and TRING pins, and reduced operating current. The RPDE in the [LMCR](#) register can be used to power down the LIU receiver.

The TE (Transmit Enable) bit in the [LMCR](#) register can be used to disable the TTIP and TRING outputs and place them in a high-impedance mode, while keeping the LIU in an active state (powered up). This is useful for equipment protection switching applications.

9.4 Initialization and Configuration

EXAMPLE DEVICE INITIALIZATION SEQUENCE:

STEP 1: Reset the device by pulling the $\overline{\text{RESETB}}$ pin low, applying power to the device, or by using the software reset bits outlined in Section 9.3. Clear all reset bits. Allow time for the reset recovery.

STEP 2: Check the Device ID in the IDR register

STEP 3: Write the [GTCCR](#) register to correctly configure the system clocks. If supplying a 1.544MHz MCLK follows this write with at least a 300ns delay in order to allow the clock system to properly adjust.

STEP 4: Write the entire remainder of the register space for each port with 00h, including reserved register locations.

STEP 5: Choose T1/J1 or E1 operation for the framers by configuring the T1/E1 bit in the [TMMR](#) and [RMMR](#) registers for each framer. Set the FRM_EN bit to 1 in the [TMMR](#) and [RMMR](#) registers. If using Software Transmit Signaling in E1 mode, program the [E1TAF](#) and [E1TNAF](#) registers as required. Configure the framer Transmit Control Registers (TCR1 – TCR4). Configure the framer Receive Control Registers (RCR1 – RCR3). Configure other framer features as appropriate.

STEP 6: Choose T1/J1 or E1 operation for the LIUs by configuring the T1J1E1S bit in the [LTRCR](#) register. Configure the Line Build Out for each LIU. Configure other LIU features as appropriate. Set the TE (Transmit Enable) bit to turn on the TTIP and TRING outputs.

STEP 7: Configure the Elastic Stores, HDLC Controller, and BERT as needed.

STEP 8: Set the INIT_DONE bit in the [TMMR](#) and [RMMR](#) registers for each framer.

9.5 Global Resources

All eight framers share a common microprocessor port. All ports share a common MCLK, and there is a common software configurable BPCLK output. A set of Global registers are located at 0F0h–0FFh and include Global resets, global interrupt status, interrupt masking, clock configuration, and the Device ID registers. See the Global Register Definitions in [Table 10-6](#). A common JTAG controller is used for all ports.

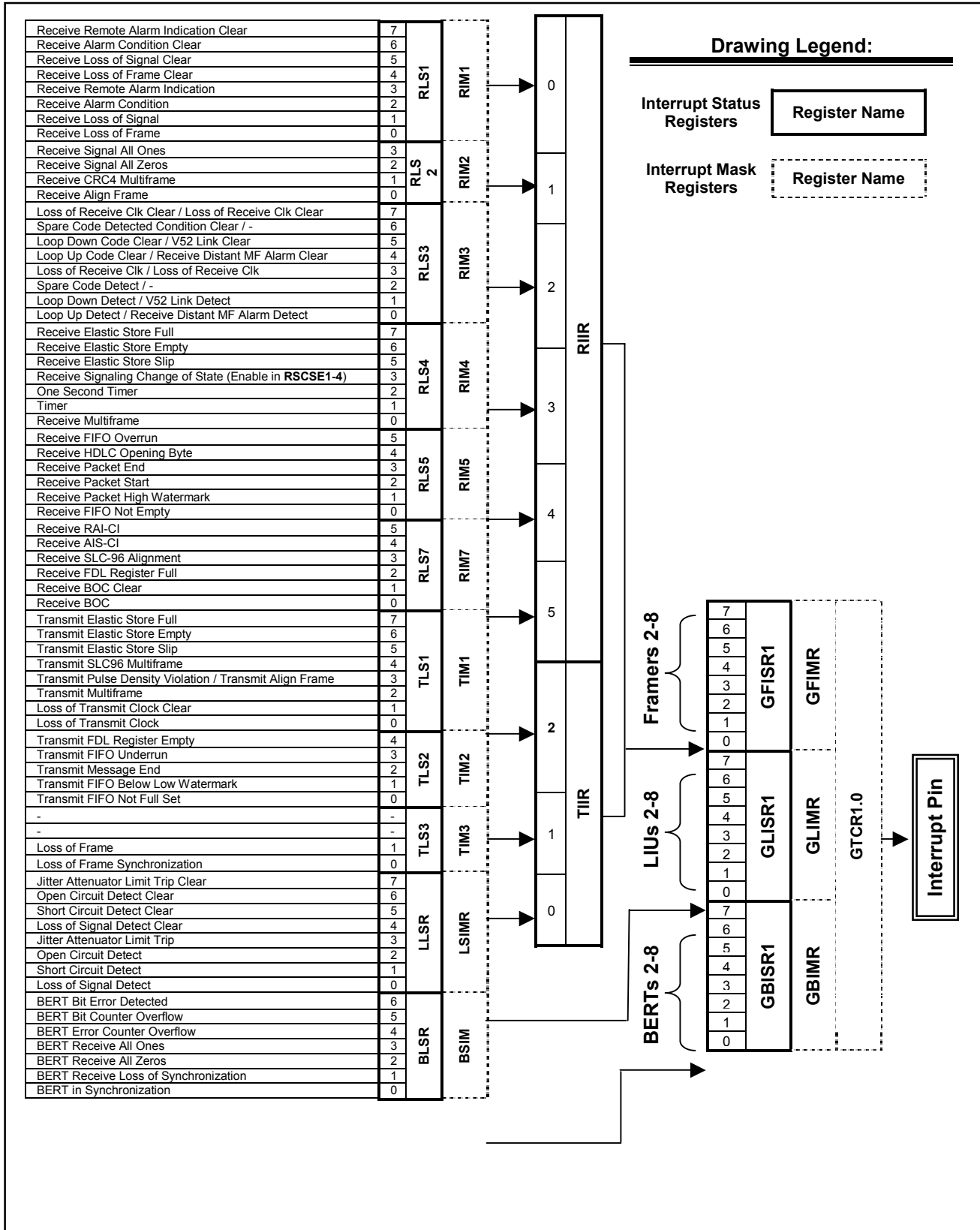
9.6 Per-Port Resources

Each port has an associated Framer, LIU, BERT, Jitter Attenuator, and Transmit/Receive HDLC controller. Each of the per-port functions has its own register space.

9.7 Device Interrupts

[Figure 9-2](#) diagrams the flow of interrupt conditions from their source status bits through the multiple levels of information registers and mask bits to the interrupt pin. When an interrupt occurs, the host can read the Global Interrupt Information registers GFISR, GLISR, and GBISR to quickly identify which of the eight transceivers is(are) causing the interrupt(s). The host can then read the specific transceiver's Interrupt Information registers (TIIR, RIIR) and the Latched Status Registers (LLSR, [BLSR](#)) to further identify the source of the interrupt(s). If TIIR or RIIR is the source, the host will then read Transmit Latched Status or the Receive Latched Status Registers for the source of the interrupt. All Interrupt Information Register bits are real-time bits that will clear once the appropriate interrupt has been serviced and cleared, as long as no additional, un-masked interrupt condition is present in the associated status register. All Latched Status bits must be cleared by the host writing a "1" to the bit location of the interrupt condition that has been serviced. Latched Status bits that have been masked via Interrupt Mask registers will be masked from the Interrupt Information Registers. The Interrupt Mask register bits prevent individual Latched Status conditions from generating an interrupt, but they do not prevent the Latched Status bits from being set. Therefore, when servicing interrupts, the user should XOR the Latched Status with the associated Interrupt Mask in order to exclude bits for which the user wished to prevent interrupt service. This architecture allows the application host to periodically poll the latched status bits for non-interrupt conditions, while using only one set of registers.

Figure 9-2. Device Interrupt Information Flow Diagram



9.8 System Backplane Interface

The DS26528 provides a versatile Backplane interface that can be configured to:

- Transmit and Receive 2 Frame Elastic Stores
- Mapping of T1 channels into a 2.048MHz backplane
- IBO mode for multiple framers to share the backplane signals
- Transmit and receive channel blocking capability
- Fractional T1/E1/J1 support
- Hardware-based (through the backplane interface) or processor-based signaling
- Flexible backplane clock providing frequencies of 2.048MHz, 4.096MHz, 8.192MHz, 16.384MHz
- Backplane clock and frame pulse (TSSYNIO) generator

9.8.1 Elastic Stores

The DS26528 contains dual, two-frame elastic stores for each framer; one for the receive direction, and one for the transmit direction. Both elastic stores are fully independent. The transmit and receive side elastic stores can be enabled/disabled independently of each other. Also, the transmit or receive elastic store can interface to either a 1.544MHz or 2.048/4.096/8.192/16.384MHz backplane without regard to the backplane rate for the other elastic store. Since the DS26528 has a common TSYCLK and RSYCLK for all eight ports, the backplane signals in each direction must be synchronous for all ports on which the elastic stores are enabled. However, the transmit and receive signals are not required to be synchronous to each other. The TIOCR and RIOCR settings should be identical for all ports on which the elastic stores are enabled.

The elastic stores have two main purposes. First, they can be used for rate conversion. When the DS26528 is in the T1 mode, the elastic stores can rate convert the T1 data stream to a 2.048MHz backplane. In E1 mode the elastic store can rate convert the E1 data stream to a 1.544MHz backplane. Secondly, they can be used to absorb the differences in frequency and phase between the T1 or E1 data stream and an asynchronous (i.e., not locked) backplane clock (which can be 1.544MHz or 2.048MHz). In this mode, the elastic stores will manage the rate difference and perform controlled slips, deleting or repeating frames of data in order to manage the difference between the network and the backplane.

If the elastic store is enabled while in E1 mode, then either CAS or CRC4 multiframe boundaries will be indicated via the RMSYNC output as controlled by the RSMS2 control bit ([RIOCR.1](#)). If the user selects to apply a 1.544MHz clock to the RSYCLK pin, then the RBCS registers will determine which channels of the received E1 data stream will be deleted. In this mode an F-bit location is inserted into the RSER data and set to one. Also, in 1.544MHz applications, the RCHBLK output will not be active in Channels 25 through 32 (or in other words, RCBR4 is not active). If the two-frame elastic buffer either fills or empties, a controlled slip will occur. If the buffer empties, then a full frame of data will be repeated at RSER and the [RLS4.5](#) and [RLS4.6](#) bits will be set to a one. If the buffer fills, then a full frame of data will be deleted and the [RLS4.5](#) and [RLS4.7](#) bits will be set to a one.

The elastic stores can also be used to multiplex T1 or E1 data streams into higher backplane rates. This is the Interleave Bus Option (IBO), which is discussed in Section [9.8.2](#). The registers related to the Elastic Stores are shown in the following table.

Table 9-2. Registers Related to the Elastic Store

REGISTER	FRAMER 1 ADDRESSES	FUNCTION
Receive I/O Configuration Register (RIOCR)	084	Sync and Clock Selection for the Receiver
Receive Elastic Store Control Register (RESCLR)	085	Receive Elastic Store Control
Receive Latched Status Register 4 (RLS4)	093	Receive Elastic Store Empty full status
Receive Interrupt Mask Register 4(RIM4)	0A3	Receive Interrupt Mask for Elastic Store
Transmit Elastic Store Control Register (TESCLR)	185	Transmit elastic control such as minimum mode
Transmit Latched Status Register 1 (TLS1)	190	Transmit Elastic Store Latched Status
Transmit Interrupt Mask Register 1 (TIM1)	1A0	Transmit Elastic Store Interrupt Mask

Note: The addresses shown above are for Framer 1. Addresses for Framers 2 to 8 can be calculated using the following: Framer N = (Framer 1 address + (n - 1) x 200hex), where n = 2 to 8 for Framers 2 to 8.

9.8.1.1 Elastic Stores Initialization

There are two elastic store initializations that may be used to improve performance in certain applications, Elastic Store Reset and Elastic Store Align. Both of these involve the manipulation of the elastic store's read and write pointers and are useful primarily in synchronous applications (RSYSCLK/TSYSCLK are locked to RCLK/TCLK respectively). The elastic store reset is used to minimize the delay through the elastic store. The elastic store align bit is used to 'center' the read/write pointers to the extent possible.

Table 9-3. Elastic Store Delay After Initialization

INITIALIZATION	REGISTER BIT	DELAY
Receive Elastic Store Reset	RESCR.2	N bytes < Delay < 1 Frame + N bytes
Transmit Elastic Store Reset	TESCR.2	N bytes < Delay < 1 Frame + N bytes
Receive Elastic Store Align	RESCR.3	½ Frame < Delay < 1 ½ Frames
Transmit Elastic Store Align	TESCR.3	½ Frame < Delay < 1 ½ Frames

N = 9 for RSZS = 0

N = 2 for RSZS = 1

9.8.1.2 Minimum Delay Mode

Elastic store minimum delay mode may be used when the elastic store's system clock is locked to its network clock (i.e., RCLK locked to RSYSCLK for the receive side and TCLK locked to TSYSCLK for the transmit side). RESCR.1 enable the receive elastic store minimum delay mode. When enabled the elastic stores will be forced to a maximum depth of 32 bits instead of the normal two-frame depth. This feature is useful primarily in applications that interface to a 2.048MHz bus. Certain restrictions apply when minimum delay mode is used. In addition to the restriction mentioned above, RSYNC must be configured as an output when the receive elastic store is in minimum delay mode and TSYNC must be configured as an output when transmit minimum delay mode is enabled. In this mode the SYNC outputs are always in frame mode (multiframe outputs are not allowed). In a typical application RSYSCLK and TSYSCLK are locked to RCLK, and RSYNC (frame output mode) is connected to TSSYNCIO (frame input mode). The slip zone select bit (RSZS at RESCR.4) must be set to '1'. All of the slip contention logic in the framer is disabled (since slips cannot occur). On power-up after the RSYSCLK and TSYSCLK signals have locked to their respective network clock signals, the elastic store reset bit (RESCR.2) should be toggled from a zero to a one to insure proper operation

9.8.1.3 Additional Receive Elastic Store Information

If the receive side elastic store is enabled, then the user must provide either a 1.544MHz or 2.048MHz clock at the RSYSCLK pin. For higher rate system clock applications, see Section 9.8.2. The user has the option of either providing a frame/multiframe sync at the RSYNC pin or having the RSYNC pin provide a pulse on frame/multiframe boundaries. If Signaling Reinsertion is enabled, the robbed-bit signaling data is realigned to the multiframe sync input on RSYNC. Otherwise, a multiframe sync input on RSYNC is treated as a simple frame boundary by the elastic store. The framer will always indicate frame boundaries on the network side of the elastic store via the RFSYNC output whether the elastic store is enabled or not. Multiframe boundaries will always be indicated via the RMSYNC output. If the elastic store is enabled, then RMSYNC will output the multiframe boundary on the backplane side of the elastic store. When the device is receiving T1 and the backplane is enabled for 2.048MHz operation, the RMSYNC signal will output the T1 multiframe boundaries as delayed through the elastic store. When the device is receiving E1 and the backplane is enabled for 1.544MHz operation, the RMSYNC signal will output the E1 multiframe boundaries as delayed through the elastic store.

If the user selects to apply a 2.048MHz clock to the RSYSCLK pin, then they can use the backplane blank channel select registers (RBCS1-4) to determine which channels will have the data output at RSER forced to all ones.

9.8.1.4 Receiving Mapped T1 Channels from a 2.048MHz Backplane

Setting the TSCLKM bit in TIOCR.4 will enable the transmit elastic store to operate with a 2.048MHz backplane (32 time slots / frame). In this mode the user can chose which of the backplane channels on TSER will be mapped into the T1 data stream by programming the Transmit Blank Channel Select registers (TBCS1-4). A logic '1' in the associated bit location will force the transmit elastic store to ignore backplane data for that channel. Typically the

user will want to program eight channels to be ignored. The default (power-up) configuration will ignore channels 25 to 32, so that the first 24 backplane channels are mapped into the T1 transmit data stream.

For example, if the user desired to transmit data from the 2.048MHz backplane channels 2-16 and 18-26, the TBCS registers should be programmed as follows:

```
TBCS1 = 01h :: ignore backplane channel 1 ::
TBCS2 = 00h
TBCS3 = 01h :: ignore backplane channel 17 ::
TBCS4 = FCh :: ignore backplane channels 27-32 ::
```

9.8.1.5 Mapping T1 Channels Onto a 2.048MHz Backplane

Setting the RSCLKM bit in RIOCR.4 will enable the receive elastic store to operate with a 2.048MHz backplane (32 time slots/frame). In this mode the user can chose which of the backplane channels on RSER receive the T1 data by programming the Receive Blank Channel Select registers

([RBCS1-4](#)). A logic '1' in the associated bit location will force RSER high for that backplane channel. Typically the user will want to program eight channels to be 'blanked.' The default (power-up) configuration will blank channels 25 to 32, so that the 24 T1 channels are mapped into the first 24 channels of the 2.048MHz backplane. If the user chooses to blank channel 1 (TS0) by setting RBCS1.0 = 1, then the F-bit will be passed into the MSB of TS0 on RSER.

For example, if:

```
RBCS1 = 01h
RBCS2 = 00h
RBCS3 = 01h
RBCS4 = FCh
```

Then on RSER:

```
channel 1 (MSB) = F-bit
channel 1 (bits 1-7) = all ones
channels 2-16 = T1 channels 1-15
channel 17 = all ones
channels 18-26 = T1 channels 16-24
channels 27-32 = all ones
```

Note that when two or more sequential channels are chosen to be blanked, the receive slip zone select bit should be set to zero. If the blank channels are distributed (such as 1, 5, 9, 13, 17, 21, 25, 29) then the RSZS bit can be set to one, which may provide a lower occurrence of slips in certain applications.

If the two-frame elastic buffer either fills or empties, a controlled slip will occur. If the buffer empties, then a full frame of data will be repeated at RSER and the RLS4.5 and RLS4.6 bits will be set to a one. If the buffer fills, then a full frame of data will be deleted and the RLS4.5 and RLS4.7 bits will be set to a one

9.8.1.6 Receiving Mapped E1 Transmit Channels from a 1.544MHz Backplane

The user can use the TSCLKM bit in TIOCR.4 to enable the transmit elastic store to operate with a 1.544MHz backplane (24 channels / frame + F-bit). In this mode the user can chose which of the E1 time slots will have all ones data inserted by programming the Transmit Blank Channel Select registers (E1TBCS1-4). A logic '1' in the associated bit location will cause the elastic store to force all ones at the outgoing E1 data for that channel. Typically the user will want to program eight channels to be 'blanked'. The default (power-up) configuration will blank channels 25 to 32, so that the first 24 E1 channels are mapped from the 24 channels of the 1.544MHz backplane.

9.8.1.7 Mapping E1 Channels onto a 1.544MHz Backplane

The user can use the RSCLKM bit in [RIOCR.4](#) to enable the receive elastic store to operate with a 1.544MHz backplane (24 channels / frame + F-bit). In this mode the user can chose which of the E1 time slots will be ignored (not transmitted onto RSER) by programming the Receive Blank Channel Select registers ([RBCS1-4](#)). A logic '1' in the associated bit location will cause the elastic store to ignore the incoming E1 data for that channel. Typically, the user will want to program eight channels to be 'ignored'. The default (power-up) configuration will ignore channels

25 to 32, so that the first 24 E1 channels are mapped into the 24 channels of the 1.544MHz backplane. In this mode the F-bit location at RSER is always set to 1.

For example, if the user wants to ignore E1 time slots 0 (channel 1) and TS 16 (channel 17), the RBCS registers would be programmed as follows:

```
RBCS1 = 01h
RBCS2 = 00h
RBCS3 = 01h
RBCS4 = FCh
```

9.8.2 IBO Multiplexer

The IBO (Interleaved Bus Operation) multiplexer is used in conjunction with the IBO function located within each framer/formatter block (controlled by the RIBOC and TIBOC registers). When enabled, the IBO multiplexer simplifies user interface by connecting bus signals internally. The IBO multiplexer eliminates the need for ganged external wiring and tri-state output drivers on the RSER and RSIG pins. This option provides a more controlled, cleaner, and lower power mode of operation.

Note that the channel block signals TCHBLK and RCHBLK are output at the rate of the of IBO selection. Hence a 4.096MHz IBO would have the channel blocks (if programmed active at the rate of 4.096MHz). Hence the particular blocking channel would be active for a duration of the channel if programmed.

The DS26528 will also support the traditional mode of IBO operation by allowing complete access to individual framers, and tri-stating the RSER and RSIG pins at the appropriate times for external bus wiring. This mode of operation is enabled per framer in the associated RIBOC and TIBOC registers, while leaving the IBO multiplexer is disabled (IBOMS0 = 0 and IBOMS1 = 0).

Figures show the equivalent internal circuit for each IBO mode. [Table 9-4](#) describes the pin function changes for each mode of the IBO multiplexer.

Table 9-4. Registers related to the IBO Multiplexer

REGISTER	FRAMER 1 ADDRESSES	FUNCTION
Global Transceiver Control Register 1 (GTCR1)	00F0	This is a Global Register for all 8 Framers. It can be used to specify Ganged Operation for the IBO
Receive Interleave Bus Operation Control Register (RIBOC)	88H	This register can be used for control of how many Framers and the corresponding Speed for the IBO links for the Receiver.
Transmit Interleave Bus Operation Control Register (TIBOC)	188H	This register can be used for control of how many Framers and the corresponding Speed for the IBO links for the Transmitter.

Note: The addresses shown above are for Framer 1. Addresses for Framers 2 to 8 can be calculated using the following: Framer N = (Framer 1 address + (n - 1) x 200hex), where n = 2 to 8 for Framers 2 to 8.

Figure 9-3. IBO Multiplexer Equivalent Circuit—4.096MHz

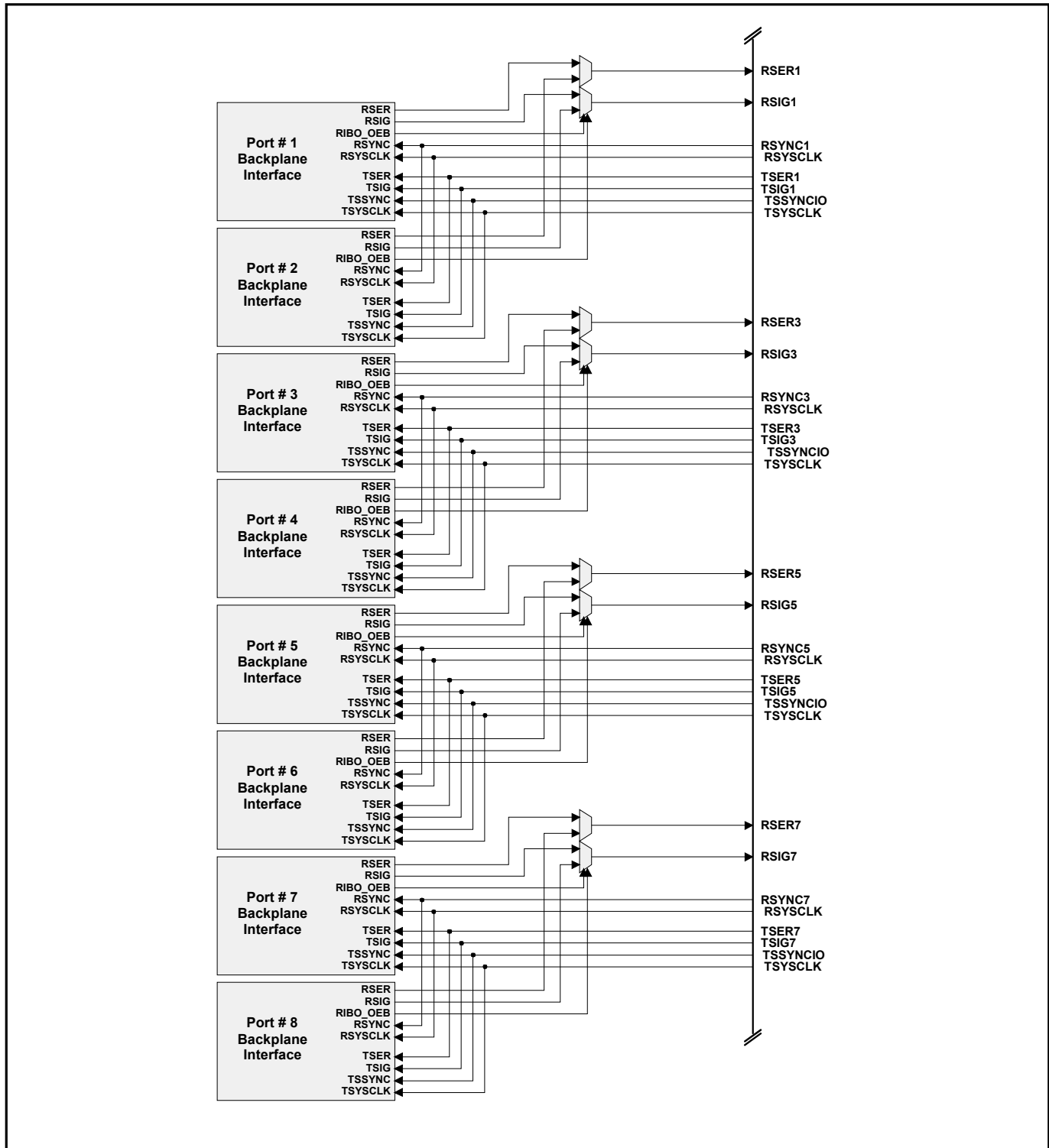


Figure 9-4. IBO Multiplexer Equivalent Circuit—8.192MHz

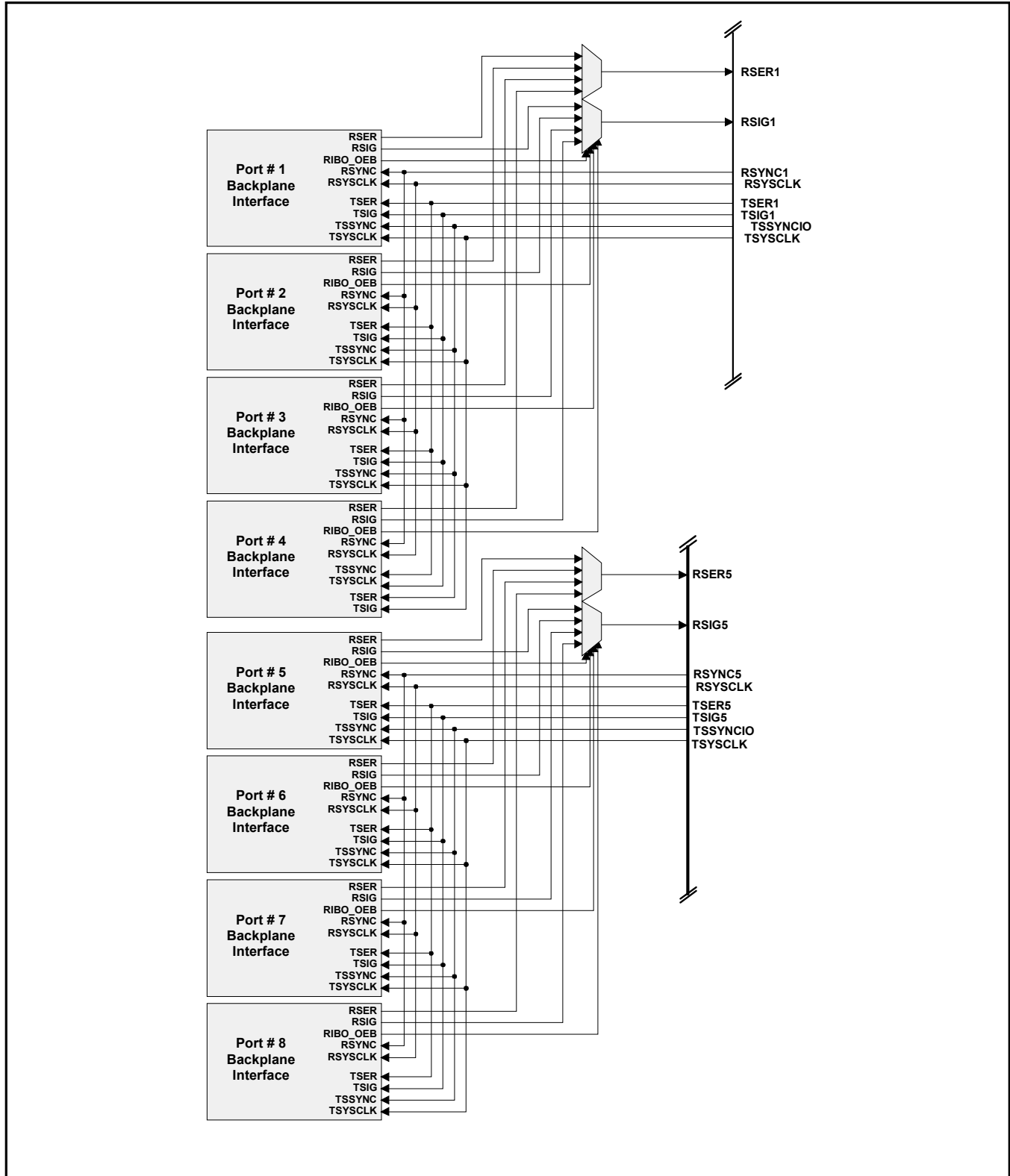


Figure 9-5. IBO Multiplexer Equivalent Circuit—16.384MHz

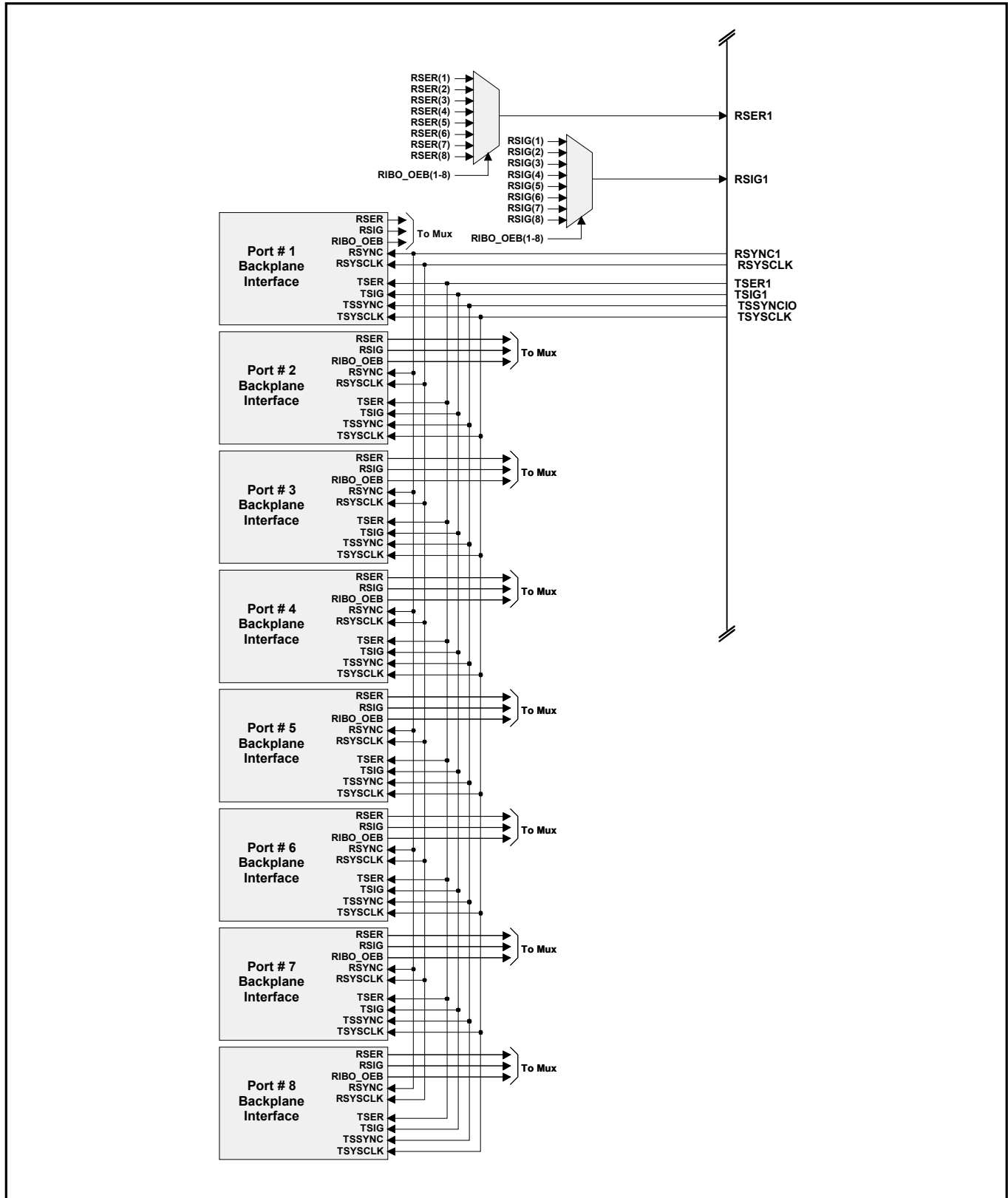


Table 9-5. RSER Output Pin Definitions

PIN NAME	NORMAL USE	4.096MHz IBO	8.192MHz IBO	16.384MHz IBO
RSER1	Rx Serial Data for Port # 1	Combined Rx Serial Data for Ports 1 & 2	Combined Rx Serial Data for Ports 1, 2, 3, & 4	Rx Serial Data for Ports 1, 2, 3, 4, 5, 6, 7, & 8
RSER2	Rx Serial Data for Port # 2	Reserved	Unused	Unused
RSER3	Rx Serial Data for Port # 3	Combined Rx Serial Data for Ports 3 & 4	Unused	Unused
RSER4	Rx Serial Data for Port # 4	Unused	Unused	Unused
RSER5	Rx Serial Data for Port # 5	Combined Rx Serial Data for Ports 5 & 6	Combined Rx Serial Data for Ports 5, 6, 7, & 8	Unused
RSER6	Rx Serial Data for Port # 6	Unused	Unused	Unused
RSER7	Rx Serial Data for Port # 7	Combined Rx Serial Data for Ports 7 & 8	Unused	Unused
RSER8	Rx Serial Data for Port # 8	Unused	Unused	Unused

Table 9-6. RSIG Output Pin Definitions

PIN NAME	NORMAL USE	4.096MHz IBO	8.192MHz IBO	16.384MHz IBO
RSIG1	Rx Signaling Data for Port # 1	Combined Rx Signaling Data for Ports 1 & 2	Combined Rx Signaling Data for Ports 1, 2, 3, & 4	Rx Signaling Data for Ports 1, 2, 3, 4, 5, 6, 7, & 8
RSIG2	Rx Signaling Data for Port # 2	Unused	Unused	Unused
RSIG3	Rx Signaling Data for Port # 3	Combined Rx Signaling Data for Ports 3 & 4	Unused	Unused
RSIG4	Rx Signaling Data for Port # 4	Unused	Unused	Unused
RSIG5	Rx Signaling Data for Port # 5	Combined Rx Signaling Data for Ports 5 & 6	Combined Rx Signaling Data for Ports 5, 6, 7, & 8	Unused
RSIG6	Rx Signaling Data for Port # 6	Unused	Unused	Unused
RSIG7	Rx Signaling Data for Port # 7	Combined Rx Signaling Data for Ports 7 & 8	Unused	Unused
RSIG8	Rx Signaling Data for Port # 8	Unused	Unused	Unused

Table 9-7. TSER Input Pin Definitions

PIN NAME	NORMAL USE	4.096MHz IBO	8.192MHz IBO	16.384MHz IBO
TSER1	Tx Serial Data for Port # 1	Combined Tx Serial Data for Ports 1 & 2	Combined Tx Serial Data for Ports 1, 2, 3, & 4	Tx Serial Data for Ports 1, 2, 3, 4, 5, 6, 7, & 8
TSER2	Tx Serial Data for Port # 2	Unused	Unused	Unused
TSER3	Tx Serial Data for Port # 3	Combined Tx Serial Data for Ports 3 & 4	Unused	Unused
TSER4	Tx Serial Data for Port # 4	Unused	Unused	Unused
TSER5	Tx Serial Data for Port # 5	Combined Tx Serial Data for Ports 5 & 6	Combined Tx Serial Data for Ports 5, 6, 7, & 8	Unused
TSER6	Tx Serial Data for Port # 6	Unused	Unused	Unused
TSER7	Tx Serial Data for Port # 7	Combined Tx Serial Data for Ports 7 & 8	Unused	Unused
TSER8	Tx Serial Data for Port # 8	Unused	Unused	Unused

Table 9-8. TSIG Input Pin Definitions

PIN NAME	NORMAL USE	4.096MHz IBO	8.192MHz IBO	16.384MHz IBO
TSIG1	Tx Signaling Data for Port # 1	Combined Tx Signaling Data for Ports 1 & 2	Combined Tx Signaling Data for Ports 1, 2, 3, & 4	Tx Signaling Data for Ports 1, 2, 3, 4, 5, 6, 7, & 8
TSIG2	Tx Signaling Data for Port # 2	Unused	Unused	Unused
TSIG3	Tx Signaling Data for Port # 3	Combined Tx Signaling Data for Ports 3 & 4	Unused	Unused
TSIG4	Tx Signaling Data for Port # 4	Unused	Unused	Unused
TSIG5	Tx Signaling Data for Port # 5	Combined Tx Signaling Data for Ports 5 & 6	Combined Tx Signaling Data for Ports 5, 6, 7, & 8	Unused
TSIG6	Tx Signaling Data for Port # 6	Unused	Unused	Unused
TSIG7	Tx Signaling Data for Port # 7	Combined Tx Signaling Data for Ports 7 & 8	Unused	Unused
TSIG8	Tx Signaling Data for Port # 8	Unused	Unused	Unused

Table 9-9. RSYNC Input Pin Definitions

PIN NAME	NORMAL USE	4.096MHz IBO	8.192MHz IBO	16.384MHz IBO
RSYNC1	Rx Frame Pulse for port # 1	Rx Frame Pulse for Ports 1 & 2	Rx Frame Pulse for Ports 1, 2, 3, & 4	Rx Frame Pulse for Ports 1, 2, 3, 4, 5, 6, 7, & 8
RSYNC2	Rx Frame Pulse for port # 2	Unused	Unused	Unused
RSYNC3	Rx Frame Pulse for port # 3	Rx Frame Pulse for Ports 3 & 4	Unused	Unused
RSYNC4	Rx Frame Pulse for port # 4	Unused	Unused	Unused
RSYNC5	Rx Frame Pulse for port # 5	Rx Frame Pulse for Ports 5 & 6	Rx Frame Pulse for Ports 5, 6, 7, & 8	Unused
RSYNC6	Rx Frame Pulse for port # 6	Unused	Unused	Unused
RSYNC7	Rx Frame Pulse for port # 7	Rx Frame Pulse for Ports 7 & 8	Unused	Unused
RSYNC8	Rx Frame Pulse for port # 8	Unused	Unused	Unused

9.8.3 H.100 (CT-Bus) Compatibility

The registers used for controlling the H.100 Backplane are [RIOCR](#) and [TIOCR](#).

The H.100 (or CT Bus) is a synchronous, bit-serial, TDM transport bus operating at 8.192MHz. The H.100 standard also allows compatibility modes to operate at 2.048MHz, 4.096MHz, or 8.192MHz. The control bit H100EN ([RIOCR.5](#)), when combined with RSYNCINV and TSSYNCINV allows the DS26528 to accept a CT-Bus-compatible frame sync signal (/CT_FRAME) at the RSYNC and TSSYNCIO (input mode) inputs. The following rules apply to the H100EN control bit:

1. The H100EN bit controls the sampling point for the RSYNC (input mode) and TSSYNCIO (input Mode) only (the RSYNC output and other sync signals are not affected).
2. The H100EN bit would always be used in conjunction with the receive and transmit elastic store buffers.
3. The H100EN bit would typically be used with 8.192MHz IBO mode, but could also be used with 4.096MHz IBO mode or 2.048MHz backplane operation.
4. The H100EN bit in RIOCR controls both RSYNC and TSSYNCIO (i.e., there is no separate control bit for the TSSYNCIO).
5. The H100EN bit does NOT invert the expected signal; RSYNCINV ([RIOCR](#)) and TSSYNCINV ([TIOCR](#)) must be set 'high' to invert the inbound sync signals.

Figure 9-6. RSYNC Input In H.100 (Ct-Bus) Mode

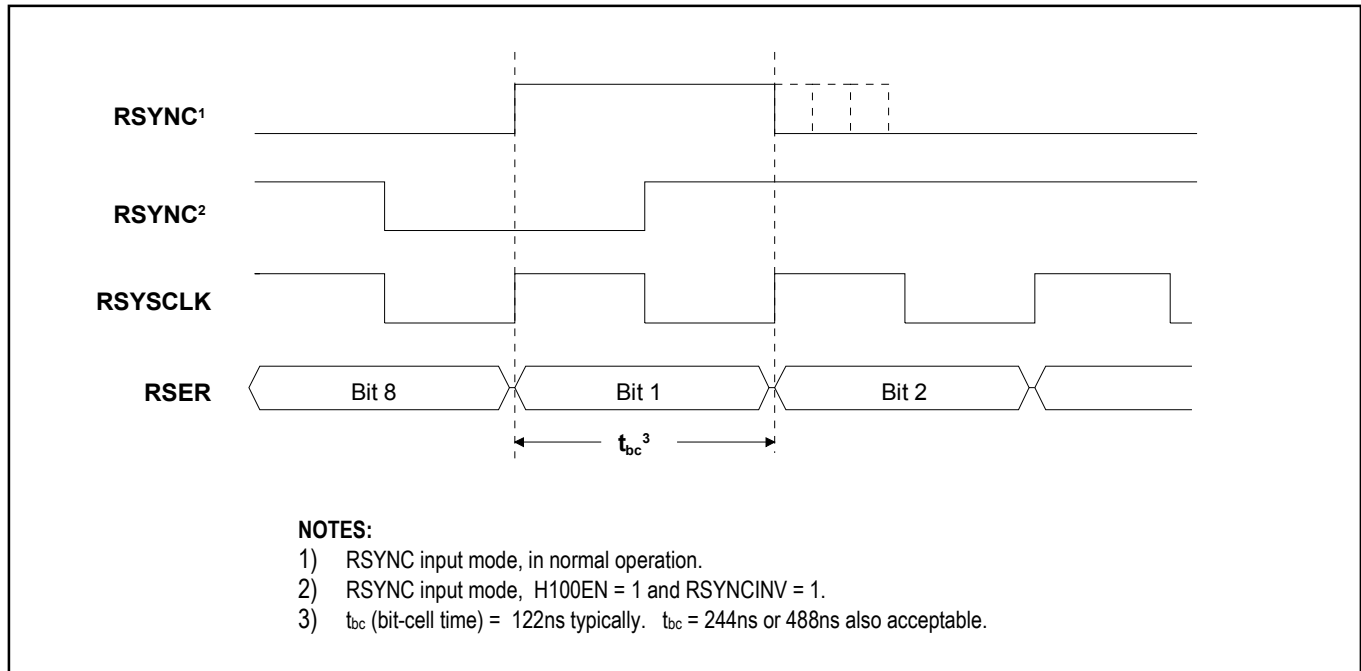
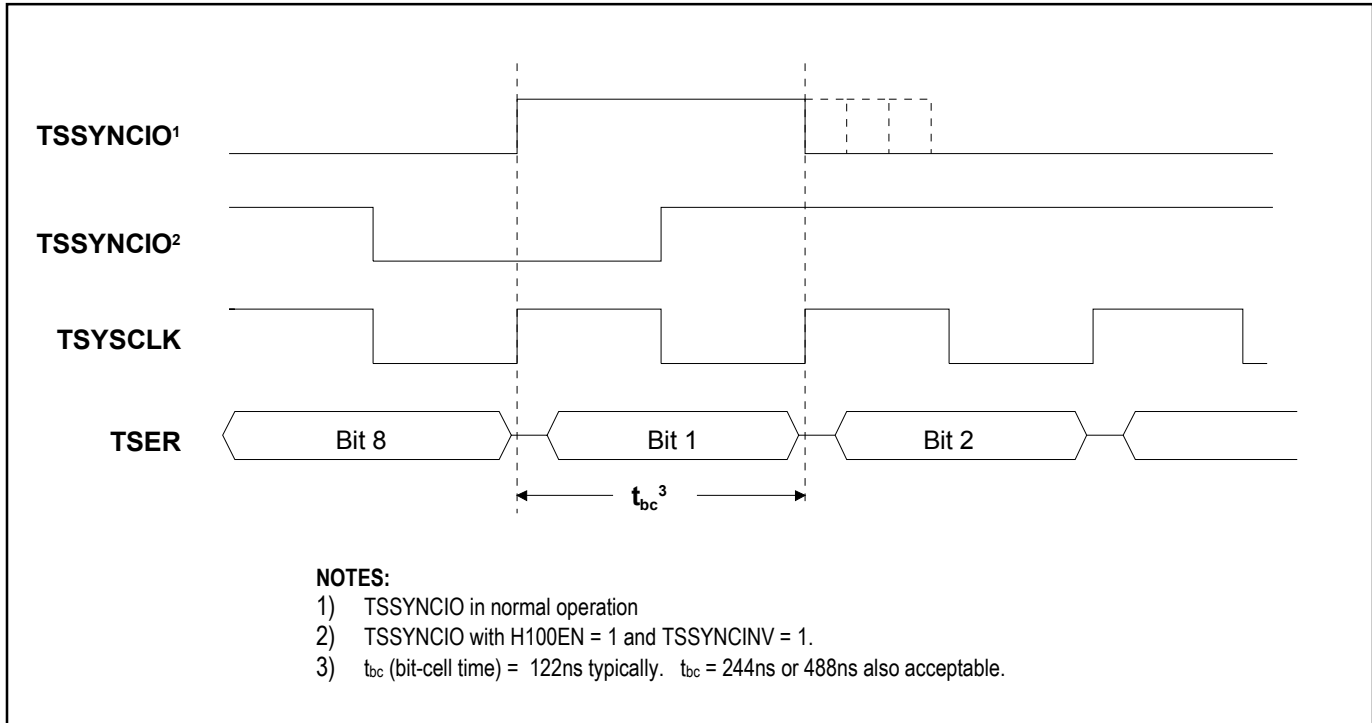


Figure 9-7. TSSYNCIO (Input Mode) Input In H.100 (CT-Bus) Mode

9.8.4 Transmit and Receive Channel Blocking Registers

The Receive Channel Blocking Registers ([RCBR1](#)/[RCBR2](#)/[RCBR3](#)/[RCBR4](#)) and the Transmit Channel Blocking Registers ([TCBR1](#)/[TCBR2](#)/[TCBR3](#)/[TCBR4](#)) control RCHBLK and TCHBLK pins respectively. The RCHBLK and TCHBLK pins are user programmable outputs that can be forced either high or low during individual channels. These outputs can be used to block clocks to a USART or LAPD controller in ISDN–PRI applications. When the appropriate bits are set to a one, the RCHBLK and TCHBLK pin will be held high during the entire corresponding channel time. When used with a T1 (1.544MHz) backplane, only TCBR1 to TCBR3 will be used. TCBR4 is included to support an E1 (2.048MHz) backplane when the elastic store is configured for T1 to E1 rate conversion ([Elastic Store](#)).

9.8.5 Transmit Fractional Support (Gapped Clock Mode)

The DS26528 can be programmed to output gapped clocks for selected channels in the receive and transmit paths to simplify connections into a USART or LAPD controller in Fractional T1/E1 or ISDN–PRI applications. When the gapped clock feature is enabled, a gated clock is output on the TCHCLK signal. The channel selection is controlled via the transmit gapped clock channel select registers ([TGCCS1](#)–[TGCCS4](#)). The transmit path is enabled for gapped clock mode with the TGCLKEN bit (TESCR.6). Both 56KBps and 64KBps channel formats are supported as determined by TESCR.7. When 56KBps mode is selected, the clock corresponding to the Data/Control bit in the channel is omitted (only the seven most significant bits of the channel have clocks).

9.8.6 Receive Fractional Support (Gapped Clock Mode)

The DS26528 can be programmed to output gapped clocks for selected channels in the receive and transmit paths to simplify connections into a USART or LAPD controller in Fractional T1/E1 or ISDN–PRI applications. When the gapped clock feature is enabled, a gated clock is output on the RCHCLK signal. The channel selection is controlled via the receive gapped clock channel select registers ([RGCCS1](#)–[RGCCS4](#)). The receive path is enabled for gapped clock mode with the RGCLKEN bit (RESR.6). Both 56KBps and 64KBps channel formats are supported as determined by RESR.7. When 56KBps mode is selected, the clock corresponding to the Data/Control bit in the channel is omitted (only the seven most significant bits of the channel have clocks).

9.9 Framers

The DS26528 framer cores are software selectable for T1, J1, or E1. The receive framer locates the frame and multiframe boundaries and monitors the data stream for alarms. It is also used for extracting and inserting signaling data, T1 FDL data, and E1 Si, and Sa bit information. The receive side framer decodes AMI, B8ZS line coding, synchronizes to the data stream, reports alarm information, counts framing/coding and CRC errors, and provides clock/data and frame sync signals to the backplane interface section. Diagnostic capabilities include loopbacks, and 16-bit loop-up and loop-down code detection. The device contains a set of internal registers for host access and control of the device.

On the transmit side, clock data and frame sync signals are provided to the framer by the backplane interface section. The framer inserts the appropriate synchronization framing patterns, alarm information, calculates and inserts the CRC codes, and provides the B8ZS (zero code suppression) and AMI line coding.

Both the transmit and receive path have an HDLC controller. The HDLC controller transmits and receives data via the framer block. The HDLC controller may be assigned to any time slot, portion of a time slot, or to FDL (T1). The HDLC controller has separate 64-byte Tx and Rx FIFO to reduce the amount of processor overhead required to manage the flow of data.

The backplane interface provides a versatile method of sending and receiving data from the host system. Elastic stores provide a method for interfacing to asynchronous systems, converting from a T1/E1 network to a 2.048MHz, 4.096MHz, 8.192MHz or N x 64kHz system backplane. The elastic stores also manage slip conditions (asynchronous interface). An IBO (Interleave Bus Option) is provided to allow multiple framers in the DS26528 to share a high-speed backplane.

9.9.1 T1 Framing

DS1 trunks contain 24 bytes of serial voice/data channels bundled with an overhead bit, the F-bit. The F-bit contains a fixed pattern for the receiver to delineate the frame boundaries. The F-bit is inserted once per frame at the beginning of the transmit frame boundary. The frames are further grouped into bundles of frames 12 for D4 and 24 for ESF.

The D4 and ESF framing modes are outlined in [Table 9-10](#) and [Table 9-11](#). In the D4 Mode, framing bit for Frame 12 is ignored if Japanese Yellow is selected.

Table 9-10. D4 Framing Mode

FRAME NUMBER	Ft	Fs	SIGNALING
1	1		
2		0	
3	0		
4		0	
5	1		
6		1	A
7	0		
8		1	
9	1		
10		1	
11	0		
12		0	B

Table 9-11. ESF Framing Mode

FRAME NUMBER	FRAMING	FDL	CRC	SIGNALING
1		√		
2			CRC1	
3		√		
4	0			
5		√		
6			CRC2	√
7		√		
8	0			
9		√		
10			CRC3	
11		√		
12				√
13		√		
14			CRC4	
15		√		
16	0			
17		√		√
18			CRC5	
19		√		
20	1			
21		√		
22			CRC6	
23		√		
24	1			√

Table 9-12. SLC-96 Framing

FRAME NUMBER	Ft	Fs	SIGNALING
1	1		
2		0	
3	0		
4		0	
5	1		
6		1	A
7	0		
8		1	
9	1		
10		1	
11	0		
12		0	B
13	1		
14		0	
15	0		
16		0	
17	1		
18		1	C
19	0		
20		1	
21	1		
22		1	
23	0		
24		C1 (concentrator bit)	D
25	1		
26		C2 (concentrator bit)	
27	0		
28		C3 (concentrator bit)	
29	1		
30		C4 (concentrator bit)	A
31	0		
32		C5 (concentrator bit)	
33	1		
34		C6 (concentrator bit)	
35	0		
36		C7 (concentrator bit)	B
37	1		
38		C8 (concentrator bit)	
39	0		
40		C9 (concentrator bit)	
41	1		
42		C10 (concentrator bit)	C
43	0		
44		C11 (concentrator bit)	
45	1		
46		0 (spoiler Bit)	
47	0		D
48		1 (Spoiler Bit)	
49	1		
50		0 (Spoiler Bit)	
51	0		
52		M1 (Maintenance Bit)	
53	1		
54		M2 (Maintenance Bit)	A
55	0		
56		M3 (Maintenance Bit)	
57	1		
58		A1 (Alarm Bit)	

FRAME NUMBER	Ft	Fs	SIGNALING
59	0		
60		A2 (Alarm Bit)	B
61	1		
62		S1 (Switch Bit)	
63	0		
64		S2 (Switch Bit)	
65	1		C
66		S3 (Switch Bit)	
67	0		
68		S4 (Switch Bit)	
69	1		
70		1(Spoiler Bit)	
71	0		
72		0	D

9.9.2 E1 Framing

The E1 Framing consists of FAS, NFAS detection as shown in the following table.

Table 9-13. E1 FAS/NFAS Framing

CRC-4 FRAME #	TYPE	1	2	3	4	5	6	7	8
0	FAS	C1	0	0	1	1	0	1	1
1	NFAS	0	1	A	Sa4	Sa5	Sa6	Sa7	Sa8
2	FAS	C2	0	0	1	1	0	1	1
3	NFAS	0	1	A	Sa4	Sa5	Sa6	Sa7	Sa8
4	FAS	C3	0	0	1	1	0	1	1
5	NFAS	1	1	A	Sa4	Sa5	Sa6	Sa7	Sa8
6	FAS	C4	0	0	1	1	0	1	1
7	NFAS	0	1	A	Sa4	Sa5	Sa6	Sa7	Sa8
8	FAS	C1	0	0	1	1	0	1	1
9	NFAS	1	1	A	Sa4	Sa5	Sa6	Sa7	Sa8
10	FAS	C2	0	0	1	1	0	1	1
11	NFAS	1	1	A	Sa4	Sa5	Sa6	Sa7	Sa8
12	FAS	C3	0	0	1	1	0	1	1
13	NFAS	E1	1	A	Sa4	Sa5	Sa6	Sa7	Sa8
14	FAS	C4	0	0	1	1	0	1	1
15	NFAS	E2	1	A	Sa4	Sa5	Sa6	Sa7	Sa8

C — C bits are the CRC-4 remainder.

A — Alarm bits.

Sa — Bits for Datalink.

Registers that are related to setting up the framing are shown in the following table.

Table 9-14. Registers Related to Setting Up the Framer

REGISTER	FRAMER 1 ADDRESSES	FUNCTION
Transmit Master Mode Register (TMMR)	180	T1E1 Mode
Transmit Control Register 1 (TCR1)	181	Source of the F-Bit
Transmit Control Register 2 (TCR2)	182	F-Bit Corruption, Selection of SLC96
Transmit Control Register 3 (TCR3)	183	ESF or D4 Mode Selection
Receive Master Mode Register (RMMR)	080	T1/E1 Selection for Receiver
Receive Control Register 1 (RCR1)	081	Resynchronization Criteria for the Framer
T1 Receive Control Register 2 (T1RCR2)	014	T1 Remote Alarm and OOF Criteria
E1 Receive Control Register 2 (E1RCR2)	082	E1 Receive Loss of Signal Criteria Selection
Receive Latched Status Register 1 (RLS1)	90	Receive Latched Status 1
Receive Interrupt Mask Register 1 (RIM1)	A0	Receive Interrupt Mask 1
Receive Latched Status Register 2 (RLS2)	91	Receive Latched Status 2
Receive Interrupt Mask Register 2 (RIM2)	A1	Receive Interrupt Mask 2
Receive Latched Status Register 4 (RLS4)	93	Receive Latched Status 4
E1 Receive Interrupt Mask Register 4 (RIM4)	A3	Receive Interrupt Mask 4
Frames Out Of Sync Count Register 1 (FOSCR1)	54	Framer Out of Sync Register 1
Frames Out Of Sync Count Register 2 (FOSCR2)	55	Framer Out of Sync Register 2
E1 Receive Align Frame Register (E1RAF)	64	RAF Byte
E1 Receive Non-Align Frame Register (E1RNAF)	65	RNAF Byte
Transmit SLC96 Control Register (T1TSLC1)	164	Transmit SLC96 Bits
Transmit SLC96 Control Register (T1TSLC2)	165	Transmit SLC96 Bits
Transmit SLC96 Control Register (T1TSLC3)	166	Transmit SLC96 Bits
Receive SLC96 Control Register 1 (T1RSLC1)	064	Receive SLC96 Bits
Receive SLC96 Control Register 1(T1RSLC2)	065	Receive SLC96 Bits
Receive SLC96 Control Register 1 (T1RSLC3)	066	Receive SLC96 Bits

Note: The addresses shown above are for Framer 1. Addresses for Framers 2 – 8 can be calculated using the following: Framer N = (Framer 1 address + (n-1) x 200hex); where n = 2 to 8 for Framers 2 to 8.

9.9.3 T1 Transmit Synchronizer

The DS26528 transmitter has the ability to identify the D4 or ESF frame boundary, as well as the CRC multiframe boundaries within the incoming NRZ data stream at TSER. The TFM (TCR3.2) control bit determines whether the transmit synchronizer searches for the D4 or ESF multiframe. Additional control signals for the transmit synchronizer are located in the [TSYNCC](#) Register. The latched status bit [TLS3.0](#) (LOFD) is provided to indicate that a Loss of Frame synchronization has occurred, and a real-time bit (LOF) which is set high when the synchronizer is searching for frame/multiframe alignment. The LOFD bit can be enabled to cause an interrupt condition on INTB.

Note that when the transmit synchronizer is used, the TSYNC signal should be set as an output

(TSIO = 1) and the recovered frame sync pulse will be output on this signal. The recovered CRC4 multi-frame sync pulse will be output if enabled with TIOCR.0 (TSM = 1).

Other key points concerning the E1 transmit synchronizer:

1. The Tx synchronizer is not operational when the transmit elastic store is enabled, including IBO modes.
2. The Tx synchronizer does not perform CRC6 alignment verification (ESF mode) and does not verify CRC4 codewords.

The Tx synchronizer does not have the ability to search for the CAS multiframe.

The registers related to the Transmit Synchronizer are shown in the following table.

Table 9-15. Registers Related to the Transmit Synchronizer

REGISTER	FRAMER 1 ADDRESSES	FUNCTION
Transmit Synchronizer Control Register (TSYNCC)	18E	Resynchronization Control for the Transmit Synchronizer
Transmit Control Register 3 (TCR3)	183	TFM Bit Selects Between D4 and ESF for the Transmit Synchronizer
Transmit Latched Status Register 3 (TLS3)	192	Provides Latched Status for the Transmit Synchronizer
Transmit Interrupt Mask Register 3 (TIM3)	1A2	Provides Mask Bits for the TLS3 Status
Transmit I/O Configuration Register (TIOCR)	184	TSYNC Should Be Set as an Output

Note: The addresses shown above are for Framer 1. Addresses for Framers 2 – 8 can be calculated using the following:
 Framer N = (Framer 1 address + (n-1) x 200hex); where n = 2 to 8 for Framers 2 to 8.

9.9.4 Signaling

The DS26528 supports both software and hardware based Signaling. Interrupts can be generated on changes of signaling data. The DS26528 is also equipped with receive signaling freeze on loss of synchronization (OOF), carrier loss or change of frame alignment. The DS26528 also has hardware pins to indicate signaling freeze.

- Flexible signaling support
 - Software or hardware based
 - Interrupt generated on change of signaling data
 - Receive signaling freeze on loss of frame, loss of signal, or change of frame alignment.
- Hardware pins for carrier loss and signaling freeze indication.

Table 9-16. Registers Related to Signaling

REGISTER	FRAMER 1 ADDRESSES	FUNCTION
Transmit Signaling Registers (TS1 to TS16)	140 to 14B (T1/J1) 140 to 14F (E1 CAS)	Transmit ABCD Signaling
Software Signaling Insertion Enable Registers (SSIE1 to SSIE4)	118, 119, 11A, 11B	When Enabled, Signaling is Inserted for the Channel
Transmit Hardware Signaling Channel Select Registers (THSCS1 to THSCS4)	1C8, 1C9, 1CA, 1CB	Bits Determine which Channels will have Signaling Inserted in Hardware Signaling Mode
Receive Signaling Control Register (RSIGC)	013	Freeze Control for Receive Signaling
Receive Signaling All-Ones Insertion Registers (T1RSAOI1 to T1RSAOI3)	038 to 03A	Registers for All-Ones Insertion (T1 Mode Only)
Receive Signaling Registers (RS1 to RS16)	040 to 04B (T1/J1) 040 to 04F (E1)	Receive Signaling Bytes
RSS1 to RSS4	098 to 09A (T1/J1) 98 to 9F (E1)	Receive Signaling Change of Status Bits
RSCSE1 to RSCSE4	A8, A9, AA, AB	Receive Signaling Change of State Interrupt Enable
RLS4	93	Receive Signaling Change of State Bit
RIM4	A3	Receive Signaling Change of State Interrupt Mask Bit
RSI1 to RSI4	0C8 to 0CB	Registers for Signaling Reinsertion

Note: The addresses shown above are for Framer 1. Addresses for Framers 2 – 8 can be calculated using the following: Framer N = (Framer 1 address + (n-1) x 200hex); where n = 2 to 8 for Framers 2 to 8.

9.9.4.1 Transmit Signaling Operation

There are two methods to provide transmit signaling data. These are processor based (i.e., software based) or hardware based. Processor-based refers to access through the transmit signaling registers, [TS1](#) –TS16, while hardware based refers to using the TSIG pins. Both methods may be used simultaneously.

9.9.4.1.1 Processor-Based Signaling

In processor-based mode, signaling data is loaded into the Transmit Signaling registers ([TS1](#) –TS16) via the host interface. On multiframe boundaries, the contents of these registers are loaded into a shift register for placement in the appropriate bit position in the outgoing data stream. The user can utilize the Transmit Multiframe Interrupt in Latched Status Register 1 (TLS1.2) to know when to update the signaling bits. The user need not update any transmit signaling register for which there is no change of state for that register.

Each Transmit Signaling Register contains the Robbed Bit signaling (TCR1.4 in T1 mode) or TS16 CAS signaling (TCR1.6 in E1 mode) for one time slot that will be inserted into the outgoing stream. Signaling data can be sourced from the TS registers on a per-channel basis by utilizing the Software Signaling Insertion Enable registers, [SSIE1](#) through SSIE4.

In T1 ESF framing mode, there are four signaling bits per channel (A, B, C, and D). TS1 – TS12 contain a full multiframe of signaling data. In T1 D4 framing mode, there are only two signaling bits per channel (A and B). In T1 D4 framing mode, the framer uses A and B bit positions for the next multiframe. The C and D bit positions become 'don't care' in D4 mode.

In E1 mode, TS16 carries the signaling information. This information can be in either CCS (Common Channel Signaling) or CAS (Channel Associated Signaling) format. The 32 time slots are referenced by two different channel number schemes in E1. In "Channel" numbering, TS0 through TS31 are labeled channels 1 through 32. In "Phone Channel" numbering TS1 through TS15 are labeled channel 1 through channel 15 and TS17 through TS31 are labeled channel 15 through channel 30.

TIME SLOT NUMBERING SCHEMES

TS	0	1	2	3	4	5	6	7	8	9	10	11	12	13	14	15	16	17	18	19	20	21	22	23	24	25	26	27	28	29	30	31
Channel	1	2	3	4	5	6	7	8	9	10	11	12	13	14	15	16	17	18	19	20	21	22	23	24	25	26	27	28	29	30	31	32
Phone Channel		1	2	3	4	5	6	7	8	9	10	11	12	13	14	15		16	17	18	19	20	21	22	23	24	25	26	27	28	29	30

9.9.4.1.2 Hardware-Based Signaling

In Hardware Based mode, signaling data is input via the TSIG pin. This signaling PCM stream is buffered and inserted to the data stream being input at the TSER pin.

Signaling data may be input via the Transmit Hardware Signaling Channel Select ([THSCS1](#)) function, the framer can be set up to take the signaling data presented at the TSIG pin and insert the signaling data into the PCM data stream that is being input at the TSER pin. The user can control which channels are to have signaling data from the TSIG pin inserted into them on a per-channel basis. The signaling insertion capabilities of the framer are available whether the transmit side elastic store is enabled or disabled. If the elastic store is enabled, the backplane clock (TSYSCLK) can be either 1.544MHz or 2.048MHz.

9.9.4.2 Receive Signaling Operation

There are two methods to access receive signaling data and provide transmit signaling data. These are processor based (i.e., software based) or hardware based. Processor-based refers to access through the transmit and receive signaling registers, [RS1](#)-RS16. Hardware based refers to the RSIG pin. Both methods may be used simultaneously.

9.9.4.2.1 Processor-Based Signaling

Signaling information is sampled from the receive data stream and copied into the receive signaling registers, [RS1](#) through RS16. The signaling information in these registers is always updated on multiframe boundaries. This function is always enabled.

9.9.4.2.2 Change Of State

In order to avoid constantly monitoring of the receive signaling registers the DS26528 can be programmed to alert the host when any specific channel or channels undergo a change of their signaling state. [RSCSE1](#) through RSCSE4 are used to select which channels can cause a change of state indication. The change of state is indicated in Latched Status Register 4 (RLS4.3). If signaling integration is enabled then the new signaling state must be constant for 3 multiframes before a change of state indication is indicated. The user can enable the INT pin to toggle low upon detection of a change in signaling by setting the Interrupt Mask bit RIM4.3. The signaling integration mode is global and cannot be enabled on a channel-by-channel basis.

The user can identify which channels have undergone a signaling change of state by reading the Receive Signaling Status ([RSS1](#) through RSS4) registers. The information from these registers will tell the user which RSx register to read for the new signaling data. All changes are indicated in the RSS1–RSS4 registers regardless of the [RSCSE1](#)–RSCSE4 registers.

9.9.4.2.3 Hardware-Based Receive Signaling

In hardware based signaling the signaling data is can be obtained from the RSER pin or the RSIG pin. RSIG is a signaling PCM stream output on a channel by channel basis from the signaling buffer. The T1 robbed bit or E1 TS16 signaling data is still present in the original data stream at RSER. The signaling buffer provides signaling data to the RSIG pin and also allows signaling data to be reinserted into the original data stream in a different alignment that is determined by a multiframe signal from the RSYNC pin. In this mode, the receive elastic store may be enabled or disabled. If the receive elastic store is enabled, then the backplane clock (RSYSCLK) can be either 1.544MHz or 2.048MHz. In the ESF framing mode, the ABCD signaling bits are output on RSIG in the lower nibble of each channel. The RSIG data is updated once a multiframe (3ms for T1 ESF, 1.5ms for T1 D4, 2ms for E1 CAS) unless a signaling freeze is in effect. In the D4 framing mode, the AB signaling bits are output twice on RSIG in the lower nibble of each channel. Hence, bits 5 and 6 contain the same data as bits 7 and 8, respectively, in each channel.

9.9.4.2.4 Receive Signaling Reinsertion at RSER

In this mode, the user will provide a multiframe sync at the RSYNC pin and the signaling data will be reinserted based on this alignment. In T1 mode, this results in two copies of the signaling data in the RSER data stream. The original signaling data based on the Fs/ESF frame positions and the realigned data based on the user supplied multiframe sync applied at RSYNC. In voice channels this extra copy of signaling data is of little consequence. Reinsertion can be avoided in data channels since this feature is activated on a per-channel basis. For reinsertion, the elastic store must be enabled and for T1, the backplane clock can be either 1.544MHz or 2.048MHz. E1 signaling information cannot be reinserted into a 1.544MHz backplane.

Signaling reinsertion mode is enabled, on a per-channel basis by setting the Receive Signaling Reinsertion Channel Select bit high in the RSI register. The channels that are to have signaling reinserted are selected by writing to the RSI1-RSI4 registers. In E1 mode, the user will generally select all channels or none for reinsertion.

9.9.4.2.5 Force Receive Signaling All Ones

In T1 mode, the user can on a per-channel basis force the robbed bit signaling bit positions to a one. This is done by using the T1RSAOI registers ([T1RSAOI1](#) to 3). The user sets the Channel Select bit in the RSAOI1–RSAOI3 registers to select the channels that are to have the signaling forced to one.

9.9.4.2.6 Receive Signaling Freeze

The signaling data in the four multiframe signaling buffers will be frozen in a known good state upon either a loss of synchronization (OOF event), carrier loss, or change of frame alignment. In T1 mode, this action meets the requirements of BellCore TR-TSY-000170 for signaling freezing. To allow this freeze action to occur, the RSFE control bit (RSIGC.1) should be set high. The user can force a freeze by setting the RSFF control bit (RSIGC.2) high. The RSIGF output pin provides a hardware indication that a freeze is in effect. The four multiframe buffer provides a three multiframe delay in the signaling bits provided at the RSIG pin (and at the RSER pin if Receive Signaling Reinsertion is enabled). When freezing is enabled (RSFE = 1), the signaling data will be held in the last known good state until the corrupting error condition subsides. When the error condition subsides, the signaling data will be held in the old state for at least an additional 9ms (4.5ms in D4 framing mode, 6ms for E1 mode) before being allowed to be updated with new signaling data.

The Receive Signaling Registers are frozen and not updated during a loss of sync condition. They will contain the most recent signaling information before the LOF occurred.

9.9.4.3 Transmit SLC-96 Operation (T1 Mode Only)

In a SLC-96 based transmission scheme, the standard Fs bit pattern is robbed to make room for a set of message fields. The SLC-96 multiframe is made up of six D4 superframes, hence it is 72 frames long. In the 72-frame SLC-96 multiframe, 36 of the framing bits are the normal Ft pattern and the other 36 bits are divided into alarm, maintenance, spoiler, and concentrator bits as well as 12-bits of the normal Fs pattern. Additional SLC-96 information can be found in BellCore document TR-TSY-000008. Registers related to the Transmit FDL are shown in the following table.

Table 9-17. Registers Related to SLC96

REGISTER	FRAMER 1 ADDRESSES	FUNCTION
Transmit FDL (T1TFDL)	162	For sending Messages in Transmit SLC-96 Ft/Fs Bits
TSCL Registers (T1TSLC1)	164, 165, 166	Registers that Control the SLC-96 Overhead Values
Transmit Control Register 2 (TCR2)	182	Transmit Control for Data Selection Source for the Ft/Fs Bits
Transmit Latched Status 1(TLS1)	190	Status Bit for Indicating Transmission of Data Link Buffer
Receive SLC 96 Register (T1RSLC1)	64, 64, 66	
Receive Latched Status 7 (RLS7)	96	Receive SLC-96 Alignment Event

Note: The addresses shown above are for Framer 1. Addresses for Framers 2 – 8 can be calculated using the following:
Framer N = (Framer 1 address + (n-1) x 200hex); where n = 2 to 8 for Framers 2 to 8.

The TFDL register is used to insert the SLC-96 message fields. To insert the SLC-96 message using the TFDL register, the user should configure the DS26528 as shown below:

- TCR2.6 (TSLC96) = 1 Enable Transmit SLC-96
- TCR2.7 (TFDLS) = 0 Source FS bits via TFDL or SLC96 formatter
- TCR3.2 (TFM) = 1 D4 framing Mode
- TCR1.6 (TFPT) = 0 Do not 'pass through' TSER F-bits.

The DS26528 will automatically insert the 12-bit alignment pattern in the Fs bits for the SLC96 data link frame. Data from the TSLC1–TSLC3 will be inserted into the remaining Fs bit locations of the SLC96 multiframe. The status bit TSLC96 located at TLS1.4 will set to indicate that the SLC-96 data link buffer has been transmitted and that the user should write new message data into TSLC1–TSLC3. The host will have 9ms after the assertion of TLS1.4 to write the registers TSLC1–TSLC3. If no new data is provided in these registers, the previous values will be retransmitted.

9.9.4.4 Receive SLC-96 Operation (T1 Mode Only)

In a SLC-96-based transmission scheme, the standard Fs bit pattern is robbed to make room for a set of message fields. The SLC-96 multiframe is made up of six D4 superframes, hence it is 72 frames long. In the 72-frame SLC-96 multiframe, 36 of the framing bits are the normal Ft pattern and the other 36-bits are divided into alarm, maintenance, spoiler, and concentrator bits as well as 12-bits of the normal Fs pattern. Additional SLC-96 information can be found in BellCore document TR-TSY-000008.

To enable the DS26528 to synchronize onto a SLC-96 pattern, the following configuration should be used:

- [RCR1.5](#) (RFM) = 1 Set to D4 framing mode
- [RCR1.3](#) (SYNCC) = 1 Set to cross-couple Ft and Fs bits
- [T1RCR2.4](#) (RSLC96) = 1 Enable SLC-96 synchronizer
- [RCR1.7](#) (SYNCT) = 0 Set to minimum sync time

The SLC-96 message bits can be extracted via the RSLC1-3 registers. The status bit RSLC96 located at RLS7.3 is useful for retrieving SLC-96 message data. The RSLC96 bit will indicate when the framer has updated the data link registers RSLC1-RSLC3 with the latest message data from the incoming data stream. Once the RSLC96 bit is set, the user will have 9ms (or until the next RSLC96 interrupt) to retrieve the most recent message data from the RSLC1/2/3 registers. Note that RSLC96 will not set if the DS26528 is unable to detect the 12-bit SLC-96 alignment pattern.

9.9.5 T1 Datalink

9.9.5.1 T1 Transmit Bit Oriented Code (BOC) Transmit Controller

The DS26528 contains a BOC generator on the transmit side and a BOC detector on the receive side. The BOC function is available only in T1 mode. The registers related to the Transmit Bit Oriented Code are shown in the following table.

Table 9-18. Registers Related to T1 Transmit BOC

REGISTER	FRAMER 1 ADDRESSES	FUNCTION
Transmit Bit Oriented Register (T1TBOC)	163	Transmit Bit Oriented Message Code Register
Transmit HDLC Control Register 2 (THC2)	113	Bit to enable Sending of Transmit BOC
Transmit Control Register 1 (TCR1)	181	Determines the Sourcing of the F-Bit

Note: The addresses shown above are for Framer 1. Addresses for Framers 2 – 8 can be calculated using the following: Framer N = (Framer 1 address + (n-1) x 200hex); where n = 2 to 8 for Framers 2 to 8.

Bits 0 through 5 in the TBOC register contain the BOC message to be transmitted. Setting SBOC = 1 ([THC2.6](#)) causes the transmit BOC controller to immediately begin inserting the BOC sequence into the FDL bit position. The transmit BOC controller automatically provides the abort sequence. BOC messages will be transmitted as long as SBOC is set. Note that the TFPT([TCR1.6](#)) control bit must be set to 'zero' for the BOC message to overwrite F-bit information being sampled on TSER.

To Transmit a BOC

1. Write 6-bit code into the TBOC register.
2. Set SBOC bit in THC2 = 1.

9.9.5.2 Receive Bit Oriented Code (BOC) Controller

The DS26528 Framers contains a BOC generator on the transmit side and a BOC detector on the receive side. The BOC function is available only in T1, ESF Mode in the Data link Bits. The following table shows the registers related to the Receive BOC operation.

Table 9-19. Registers Related to T1 Receive BOC

REGISTER	FRAMER 1 ADDRESSES	FUNCTION
Receive Bit Oriented Control (T1RBOCC)	015	Controls the Receive BOC Function
Receive Bit Oriented Control (T1RBOC)	063	Receive Bit Oriented Message
Receive Latched Status 7(RLS7)	096	Indicates Changes to the Receive Bit Oriented Messages
Receive Interrupt Mask 7 (RIM7)	0A6	Mask Bits for RBOC for Generation of Interrupts

Note: The addresses shown above are for Framer 1. Addresses for Framers 2 – 8 can be calculated using the following: Framer N = (Framer 1 address + (n-1) x 200hex); where n = 2 to 8 for Framers 2 to 8.

In ESF mode, the DS26528 continuously monitors the receive message bits for a valid BOC message. The BOC Detect (BD) status bit at RLS7.0 will be set once a valid message has been detected for time determined by the Receive BOC Filter bits RBF0 and RBF1 in the RBOCC register. The 6-bit BOC message will be available in the RBOC register. Once the user has cleared the BD bit, it will remain clear until a new BOC is detected (or the same BOC is detected following a BOC Clear event). The BOC Clear (BC) bit at RLS7.1 is set when a valid BOC is no longer being detected for a time determined by the Receive BOC Disintegration bits RBD0 and RBD1 in the RBOCC register.

The BD and BC status bits can create a hardware interrupt on the INTB signal as enabled by the associated interrupt mask bits in the RIM7 register.

9.9.5.3 Legacy T1 Transmit FDL

It is recommended that the DS26528's built-in BOC or HDLC controllers be used for most applications requiring access to the FDL. The registers related to control of the Transmit FDL are presented in the following table.

Table 9-20. Registers Related to T1 Transmit FDL

REGISTER	FRAMER 1 ADDRESSES	FUNCTION
Transmit FDL (T1TFDL)	162	FDL Code Used to Insert Transmit FDL
Transmit Control 2 (TCR2)	182	Defines the Source of the FDL
Transmit Latched Status 2(TLS2)	191	Transmit FDL Empty Bit
Transmit Interrupt Mask 2 (TIM2)	1A1	Mask Bit for TFDL Empty

Note: The addresses shown above are for Framer 1. Addresses for Framers 2 – 8 can be calculated using the following:
Framer N = (Framer 1 address + (n-1) x 200hex); where n = 2 to 8 for Framers 2 to 8.

When enabled with TCR2.7, the transmit section will shift out into the T1 data stream, either the FDL (in the ESF framing mode) or the Fs bits (in the D4 framing mode) contained in the Transmit FDL register (TFDL). When a new value is written to the TFDL, it will be multiplexed serially (LSB first) into the proper position in the outgoing T1 data stream. After the full eight bits has been shifted out, the framer will signal the host controller that the buffer is empty and that more data is needed by setting the TLS2.4 bit to a one. The INT will also toggle low if enabled via TIM2.4. The user has 2ms to update the TFDL with a new value. If the TFDL is not updated, the old value in the TFDL will be transmitted once again. Note that in this mode, no zero stuffing will be applied to the FDL data. It is strongly suggested that the HDLC controller be used for FDL messaging applications.

In the D4 framing mode, the framer uses the TFDL register to insert the Fs framing pattern. To accomplish this the TFDL register must be programmed to '1C'h and TCR2.7 should be set to '0' (source Fs data from the TFDL register)

The Transmit FDL Register (TFDL) contains the Facility Data Link (FDL) information that is to be inserted on a byte basis into the outgoing T1 data stream. The LSB is transmitted first. In D4 mode, only the lower six bits are used.

9.9.5.4 Legacy T1 Receive FDL

It is recommended that the DS26528's built-in BOC or HDLC controllers be used for most applications requiring access to the FDL. The registers related to the Receive FDL are shown in the following table.

Table 9-21. Registers Related to T1 Receive FDL

REGISTER	FRAMER 1 ADDRESSES	FUNCTION
Receive FDL (T1RFDL)	162	FDL Code Used to Insert Transmit FDL
Receive Latched Status 7(RLS7)	96	Receive FDL Full Bit is in this Register
Receive Interrupt Mask 7(RIM7)	1A1	Mask Bit for RFDL Full

Note: The addresses shown above are for Framer 1. Addresses for Framers 2 – 8 can be calculated using the following:
Framer N = (Framer 1 address + (n-1) x 200hex); where n = 2 to 8 for Framers 2 to 8.

In the receive section, the recovered FDL bits or Fs bits are shifted bit-by-bit into the Receive FDL register (RFDL). Since the RFDL is 8 bits in length, it will fill up every 2ms (8 times 250µs). The framer will signal an external controller that the buffer has filled via the RLS7.2 bit. If enabled via RIM7.2, the INTB pin will toggle low indicating that the buffer has filled and needs to be read. The user has 2ms to read this data before it is lost. Note that no zero de-stuffing is applied to the for the data provided through the RFDL register. The Receive FDL Register (RFDL) reports the incoming Facility Data Link (FDL) or the incoming Fs bits. The LSB is received first. In D4 framing mode, RFDL updates on multiframe boundaries and reports only the Fs bits.

9.9.6 E1 Datalink

The registers related to E1 Datalink is shown in the following table:

REGISTER	FRAMER 1 ADDRESSES	FUNCTION
E1RAF	64	Receive Frame Alignment Register
E1RNAF	65	Receive Non-Frame Alignment Register
E1RsiAF	66	Receive Si Bits of the Frame Alignment Frames
E1RSiNAF	67	Receive Si Bits of the Non-Frame Alignment Frames
E1RSa4 to RSA8	69 to 6D	Receive Sa Bits
E1TAF	164	Transmit Align Frame Register
E1TNAF	165	Transmit Non-Align Frame Register
E1TSiAF	166	Transmit Si Bits of the Frame Alignment Frames
E1TSiNAF	167	Transmit Si Bits of the Non-Frame Alignment Frames
E1TSa4 to TSA8	169 to 16D	Transmit Sa4 to Sa8
E1TSACR	114	Transmit Source3 of Sa Control

Note: The addresses shown above are for Framer 1. Addresses for Framers 2 – 8 can be calculated using the following:
Framer N = (Framer 1 address + (n-1) x 200hex); where n = 2 to 8 for Framers 2 to 8.

9.9.6.1 Additional E1 Receive Sa and Si Bit Receive Operation (E1 Mode)

The DS26528, when operated in the E1 mode, provides for access to both the Sa and the Si bits via two methods. The first involves using the internal [E1RAF/E1RNAF](#) and [E1TAF/E1TNAF](#) registers. The second method involves an expanded version of the first method.

9.9.6.1.1 Internal Register Scheme Based On Double-Frame (Method 1)

On the receive side, the [E1RAF](#) and [E1RNAF](#) registers will always report the data as it received in the Sa and Si bit locations. The [E1RAF](#) and [E1RNAF](#) registers are updated on align frame boundaries. The setting of the Receive Align Frame bit in Latched Status Register 2 (RLS2.0) will indicate that the contents of the RAF and RNAF have been updated. The host can use the RLS2.0 bit to know when to read the [E1RAF](#) and [E1RNAF](#) registers. The host has 250µs to retrieve the data before it is lost.

9.9.6.1.2 Internal Register Scheme Based On CRC4 Multiframe

On the receive side, there is a set of eight registers ([E1RsiAF](#), [E1RSiNAF](#), [E1RRA](#), [E1RSa4](#) to [E1RSa8](#)) that report the Si and Sa bits as they are received. These registers are updated with the setting of the Receive CRC4 Multiframe bit in Latched Status Register 2 (RLS2.1). The host can use the RLS2.1 bit to know when to read these registers. The user has 2 ms to retrieve the data before it is lost. See the following register descriptions for additional information.

9.9.6.2 Internal Register Scheme Based On CRC4 Multiframe

On the transmit side there is a set of eight registers ([E1TSiAF](#), [E1TSiNAF](#), [E1TRA](#), [E1TSa4](#) to [E1TSa8](#)) that via the Transmit Sa Bit Control Register ([E1TSACR](#)), can be programmed to insert both Si and Sa data. Data is sampled from these registers with the setting of the Transmit Multiframe bit in Status Register 1 (TLS1.3). The host can use the TLS1.3 bit to know when to update these registers. It has 2ms to update the data or else the old data will be retransmitted. See the register descriptions below.

9.9.7 Maintenance and Alarms

The DS26528 provides extensive functions for alarm detection and generation. It also provides diagnostic functions for monitoring of performance and sending of diagnostic information:

- Real-time and latched status bits, interrupts and interrupt mask for transmitter and receiver
- LOS detection
- RIA detection and generation
- PDV Violation detection
- Error counters
- DS0 Monitoring
- Milliwatt generation and detection
- Slip Buffer Status for Transmit and Receive

Some of the Registers related to Maintenance and Alarms are as follows:

Table 9-22. Registers Related to Maintenance and Alarms

REGISTER	FRAMER 1 ADDRESSES	FUNCTION
Receive Real-Time Status Register 1 (RRTS1)	0B0	Real-Time Receive Status 1
Receive Interrupt Mask 1(RIM1)	0A0	Real-Time Interrupt Mask 1
Receive Latched Status Register 2 (RLS2)	91	Real-Time Latched Status 2
Receive Real-Time Status Register 3 (RRTS3)	0B2	Real-Time Receive Status 2
Receive Latched Status Register 3 (RLS3)	92	Real-Time Latched Status 3
Receive Interrupt Mask Register 3 (RIM3)	A2	Real-Time Interrupt Mask 3
Receive Interrupt Mask Register 4 (RIM4)	A3	Real-Time Interrupt Mask 3
Rx Latched Status 7 (RLS7)	96	Real-Time Latched Status 7
Rx Interrupt Mask Reg 7 (RIM7)	A6	Real-Time Interrupt Mask 7
Tx Latched Status 1 (TLS1)	190	Loss of Transmit Clock Status, TPDV, etc.
Tx Latched Status 3 (SYNC)(TLS3)	192	Loss of Frame Status
Rx DS0 Monitor (RDS0M)	060	Receive DS0 Monitor
Rx Error Count Configuration (ERCNT)	086	Configuration of the Error Counters
Line Code Violation Count Register 1 (LCVCR1)	050	Line Code Violation Counter
Line Code Violation Count Register 2 (LCVCR2)	051	Line Code Violation Counter
Path Code Violation Count Register 1 (PCVCR1)	052	Receive Path Code Violation Counter 1
Path Code Violation Count Register 2 (PCVCR2)	053	Receive Path Code Violation Counter 2
Frames Out Of Sync Count Register 1 (FOSCR1)	054	Receive Frame Out of Sync Counter 1
Frames Out Of Sync Count Register 2 (FOSCR2)	055	Receive Frame Out of Sync Counter 2

Note: The addresses shown above are for Framer 1. Addresses for Framers 2 – 8 can be calculated using the following: Framer N = (Framer 1 address + (n-1) x 200hex); where n = 2 to 8 for Framers 2 to 8.

9.9.7.1 Status and Information Bit Operation

When a particular event has occurred (or is occurring), the appropriate bit in one of these registers will be set to a one. Status bits may operate in either a latched or real-time fashion. Some latched bits may be enabled to generate a hardware interrupt via the INTB signal.

Real-Time Bits

Some status bits operate in a real-time fashion. These bits are read-only and indicate the present state of an alarm or a condition. Real-time bits will remain stable, and valid during the host read operation. The current value of the internal status signals can be read at any time from the real-time status registers without changing any the latched status register bits

Latched Bits

When an event or an alarm occurs and a latched bit is set to a one, it will remain set until cleared by the user. These bits typically respond on a 'change-of-state' for an alarm, condition, or event; and operate in a read-then-write fashion. The user should read the value of the desired status bit, and then write a '1' to that particular bit location in order to clear the latched value (write a '0' to locations not to be cleared). Once the bit is cleared, it will not be set again until the event has occurred again.

Mask Bits

Some of the alarms and events can be either masked or unmasked from the interrupt pin via the Interrupt Mask Registers (RIMx). When unmasked, the INTB signal will be forced low when the enabled event or condition occurs. The INTB pin will be allowed to return high (if no other unmasked interrupts are present) when the user reads then clears (with a write) the alarm bit that caused the interrupt to occur. Note that the latched status bit and the INTB pin will clear even if the alarm is still present.

Note that some conditions may have multiple status indications. For example, Receive Loss of Frame (RLOF) provides the following indications:

RRTS1.0 (RLOF)	Real-time indication that the receiver is not synchronized with incoming data stream. Read-only bit that remains high as long as the condition is present.
RLS1.0 (RLOFD)	Latched indication that the receiver has loss synchronization since the bit was last cleared. Bit will clear when written by the user, even if the condition is still present (rising edge detect of RRTS1.0).
RLS1.4 (RLOFC)	Latched indication that the receiver has reacquired synchronization since the bit was last cleared. Bit will clear when written by the user, even if the condition is still present (falling edge detect of RRTS1.0).

Table 9-23. T1 Alarm Criteria

ALARM	SET CRITERIA	CLEAR CRITERIA
AIS (Blue Alarm) (see note 1 below)	when over a 3 ms window, 5 or less zeros are received	when over a 3 ms window, 6 or more zeros are received
RAI (Yellow Alarm) 1. D4 bit 2 mode (T1RCR2.0 = 0) 2. D4 12th F-bit mode (T1RCR2.0 = 1; this mode is also referred to as the “Japanese Yellow Alarm”) 3. ESF mode	when bit 2 of 256 consecutive channels is set to zero for at least 254 occurrences when the 12th framing bit is set to one for two consecutive occurrences when 16 consecutive patterns of 00FF appear in the FDL	when bit 2 of 256 consecutive channels is set to zero for less than 254 occurrences when the 12th framing bit is set to zero for two consecutive occurrences when 14 or less patterns of 00FF hex out of 16 possible appear in the FDL
LOS Loss of Signal (this alarm is also referred to as Receive Carrier Loss (RCL))	when 192 consecutive zeros are received	when 14 or more ones out of 112 possible bit positions are received starting with the first one received

NOTES:

- The definition of the Alarm Indication Signal (Blue Alarm) is an unframed all ones signal. AIS detectors should be able to operate properly in the presence of a $10E-3$ error rate and they should not falsely trigger on a framed all ones signal. The AIS alarm criteria in the DS26528 has been set to achieve this performance. It is recommended that the RAIS bit be qualified with the RLOF bit.
- The following terms are equivalent:
RAIS = Blue Alarm
RLOS = RCL
RLOF = Loss of Frame (conventionally RLOS for Dallas Semiconductor devices)
RRAI = Yellow Alarm

9.9.8 E1 Automatic Alarm Generation

The device can be programmed to automatically transmit AIS or Remote Alarm. When automatic AIS generation is enabled ([TCR2.6](#) = 1), the device monitors the receive side framer to determine if any of the following conditions are present/ loss of receive frame synchronization, AIS alarm (all one’s) reception, or loss of receive carrier (or signal). If any one (or more) of the above conditions is present, then the framer will either force an AIS.

When automatic RAI generation is enabled ([TCR2.5](#) = 1), the framer monitors the receive side to determine if any of the following conditions are present/ loss of receive frame synchronization, AIS alarm (all one’s) reception, or loss of receive carrier (or signal) or if CRC4 multiframe synchronization cannot be found within 128ms of FAS synchronization (if CRC4 is enabled). If any one (or more) of the above conditions is present, then the framer will transmit a RAI alarm. RAI generation conforms to ETS 300 011 and ITU G.706 specifications.

Note: It is an illegal state to have both automatic AIS generation and automatic Remote Alarm generation enabled at the same time.

9.9.8.1 Receive AIS-CI and RAI-CI Detection

AIS-CI is a repetitive pattern of 1.26 seconds. It consists of 1.11 seconds of an unframed all ones pattern and 0.15 seconds of all ones modified by the AIS-CI signature. The AIS-CI signature is a repetitive pattern 6176 bits in length in which, if the first bit is numbered bit 0, bits 3088, 3474 and 5790 are logical zeros and all other bits in the pattern are logical ones ([T1.403](#)). AIS-CI is an unframed pattern, so it is defined for all T1 framing formats. The RAIS-CI bit is set when the AIS-CI pattern has been detected and RAIS ([RRTS1.2](#)) is set. RAIS-CI is a latched bit that should be cleared by the host when read. RAIS-CI will continue to set approximately every 1.2 seconds that the condition is present. The host will need to ‘poll’ the bit, in conjunction with the normal AIS indicators to determine when the condition has cleared.

RAI-CI is a repetitive pattern within the ESF data link with a period of 1.08 seconds. It consists of sequentially interleaving 0.99 seconds of “00000000 11111111” (right-to-left) with 90 ms of “00111110 11111111”. The RRAI-CI bit is set when a bit oriented code of “00111110 11111111” is detected while RRAI ([RRTS1.3](#)) is set. The RRAI-CI detector uses the receive BOC filter bits (RBF0 & RBF1) located in RBOCC to determine the integration time for RAI-CI detection. Like RAIS-CI, the RRAI-CI bit is latched and should be cleared by the host when read. RRAI-CI will continue to set approximately every 1.1 seconds that the condition is present. The host will need to ‘poll’ the bit, in conjunction with the normal RAI indicators to determine when the condition has cleared. It may be useful to enable the 200ms ESF RAI integration time with the RAIE control bit ([T1RCR2.1](#)) in networks that utilize RAI-CI.

9.9.8.2 T1 Receive Side Digital Milliwatt Code Generation

Receive side digital milliwatt code generation involves using the Receive Digital Milliwatt Registers (RDMR1/2/3) to determine which of the 24 T1 channels of the T1 line going to the backplane should be overwritten with a digital milliwatt pattern. The digital milliwatt code is an 8-byte repeating pattern that represents a 1kHz sine wave (1E/0B/0B/1E/9E/8B/8B/9E). Each bit in the RDMRx registers, represents a particular channel. If a bit is set to a one, then the receive data in that channel will be replaced with the digital milliwatt code. If a bit is set to zero, no replacement occurs.

9.9.9 Error Count Registers

The DS26528 contains four counters that are used to accumulate line coding errors, path errors and synchronization errors. Counter update options include one second boundaries, 42ms (T1 mode only), 62.5ms (E1 mode only) or manually. See Error Counter Configuration Register ([ERCNT](#)). When updated automatically, the user can use the interrupt from the timer to determine when to read these registers. All four counters will saturate at their respective maximum counts and they will not rollover (note: only the Line Code Violation Count Register has the potential to over-flow but the bit error would have to exceed 10E-2 before this would occur).

The DS26528 can share the one-second timer from port #1 across all ports. All DS26528 error/performance counters can be configured to update on the shared one-second source, or a separate manual update signal input. See the [ERCNT](#) register for more information. By allowing multiple framer cores to synchronously latch their counters, the host software can be streamlined to read and process performance information from multiple spans in a more controlled manner.

9.9.9.1 Line Code Violation Count Register (LCVCR)

Either bipolar violations or code violations can be counted. Bipolar violations are defined as consecutive marks of the same polarity. In T1 mode, if the B8ZS mode is set for the receive side, then B8ZS codewords are not counted as BPVs. In E1 mode, if the HDB3 mode is set for the receive side, then HDB3 codewords are not counted as BPVs. If [ERCNT.0](#) is set, then the LVC counts code violations as defined in ITU O.161. Code violations are defined as consecutive bipolar violations of the same polarity. In most applications, the framer should be programmed to count BPVs when receiving AMI code and to count CVs when receiving B8ZS or HDB3 code. This counter increments at all times and is not disabled by loss of sync conditions. The counter saturates at 65,535 and will not rollover. The bit error rate on an E1 line would have to be greater than 10E-2 before the VCR would saturate. See the following table for details of exactly what the LCVCRs count.

Table 9-24. T1 Line Code Violation Counting Options

COUNT EXCESSIVE ZEROS? (ERCNT.0)	B8ZS ENABLED? (RCR1.6)	WHAT IS COUNTED IN THE LCVCR1 , LCVCR2
no	no	BPVs
yes	no	BPVs + 16 consecutive zeros
no	yes	BPVs (B8ZS/HDB3 codewords not counted)
yes	yes	BPVs + 8 consecutive zeros

Table 9-25. E1 Line Code Violation Counting Options

E1 CODE VIOLATION SELECT (ERCNT.0)	WHAT IS COUNTED IN THE LCVCRs
0	BPVs
1	CVs

9.9.9.2 Path Code Violation Count Register (PCVCR)

In T1 operation, the Path Code Violation Count Register records either Ft, Fs, or CRC6 errors. When the receive side of a framer is set to operate in the T1 ESF framing mode, PCVCR will record errors in the CRC6 codewords. When set to operate in the T1 D4 framing mode, PCVCR will count errors in the Ft framing bit position. Via the [ERCNT.2](#) bit, a framer can be programmed to also report errors in the Fs framing bit position. The PCVCR will be disabled during receive loss of synchronization (RLOF = 1) conditions. See [Table 9-26](#) for a detailed description of exactly what errors the PCVCR counts in T1 operation.

In E1 operation, the Path Code Violation Count register records CRC4 errors. Since the maximum CRC4 count in a one second period is 1000, this counter cannot saturate. The counter is disabled during loss of sync at either the FAS or CRC4 level; it will continue to count if loss of multiframe sync occurs at the CAS level.

The Path Code Violation Count Register 1 ([PCVCR1](#)) is the most significant word and [PCVCR2](#) is the least significant word of a 16-bit counter that records path violations (PVs).

Table 9-26. T1 Path Code Violation Counting Arrangements

FRAMING MODE	COUNT Fs ERRORS?	WHAT IS COUNTED IN THE PCVCRs?
D4	no	errors in the Ft pattern
D4	yes	errors in both the Ft & Fs patterns
ESF	don't care	errors in the CRC6 codewords

9.9.9.3 Frames Out Of Sync Count Register (FOSCR)

The FOSCR is used to count the number of multiframes that the receive synchronizer is out of sync. This number is useful in ESF applications needing to measure the parameters Loss Of Frame Count (LOFC) and ESF Error Events as described in AT&T publication TR54016. When the FOSCR is operated in this mode, it is not disabled during receive loss of synchronization (RLOF = 1) conditions. The FOSCR has alternate operating mode whereby it will count either errors in the Ft framing pattern (in the D4 mode) or errors in the FPS framing pattern (in the ESF mode). When the FOSCR is operated in this mode, it is disabled during receive loss of synchronization (RLOF = 1) conditions. See [Table 9-27](#) for a detailed description of what the FOSCR is capable of counting.

In E1 mode, The FOSCR counts word errors in the Frame Alignment Signal in time slot 0. This counter is disabled when RLOF is high. FAS errors will not be counted when the framer is searching for FAS alignment and/or synchronization at either the CAS or CRC4 multiframe level. Since the maximum FAS word error count in a one second period is 4000, this counter cannot saturate.

The Frames Out of Sync Count Register 1 ([FOSCR1](#)) is the most significant word and [FOSCR2](#) is the least significant word of a 16-bit counter that records frames out of sync.

Table 9-27. T1 Frames Out Of Sync Counting Arrangements

FRAMING MODE (RCR1.5)	COUNT MOS OR F-BIT ERRORS (ERCNT.1)	WHAT IS COUNTED IN THE FOSCR1 and FOSCR2
D4	MOS	number of multiframes out of sync
D4	F-Bit	errors in the Ft pattern
ESF	MOS	number of multiframes out of sync
ESF	F-Bit	errors in the FPS pattern

9.9.9.4 E-Bit Counter (EBCR)

This counter is only available in E1 mode. E-bit Count Register 1 ([E1EBCR1](#)) is the most significant word and [E1EBCR2](#) is the least significant word of a 16-bit counter that records Far End Block Errors (FEBE) as reported in the first bit of frames 13 and 15 on E1 lines running with CRC4 multiframe. These count registers will increment once each time the received E-bit is set to zero. Since the maximum E-bit count in a one second period is 1000, this counter cannot saturate. The counter is disabled during loss of sync at either the FAS or CRC4 level; it will continue to count if loss of multiframe sync occurs at the CAS level.

9.9.10 DS0 Monitoring Function

The DS26528 can monitor one DS0 (64kbps) channel in the transmit direction and one DS0 channel in the receive direction at the same time. The registers related to the control of transmit and receive DS0 are shown in the following table.

Table 9-28. Registers Related to DS0 Monitoring

REGISTER	FRAMER 1 ADDRESSES	FUNCTION
TDS0SEL	189	Transmit Channel to be Monitored
TDS0M	1BB	The Monitored Data
RDS0SEL	012H	Receive Channel to be Monitored
RDS0M	060H	The Monitored Data

Note: The addresses shown above are for Framer 1. Addresses for Framers 2 – 8 can be calculated using the following: Framer N = (Framer 1 address + (n-1) x 200hex); where n = 2 to 8 for Framers 2 to 8.

In the transmit direction the user will determine which channel is to be monitored by properly setting the TCM0 to TCM4 bits in the TDS0SEL register. In the receive direction, the RCM0 to RCM4 bits in the RDS0SEL register need to be properly set. The DS0 channel pointed to by the TCM0 to TCM4 bits will appear in the Transmit DS0 Monitor (TDS0M) register and the DS0 channel pointed to by the RCM0 to RCM4 bits will appear in the Receive DS0 (RDS0M) register. The TCM4 to TCM0 and RCM4 to RCM0 bits should be programmed with the decimal decode of the appropriate T1 or E1 channel. T1 channels 1 through 24 map to register values 0 through 23. E1 channels 1 through 32 map to register values 0 through 31. For example, if DS0 channel 6 in the transmit direction and DS0 channel 15 in the receive direction needed to be monitored, then the following values would be programmed into TDS0SEL and RDS0SEL:

TCM4 = 0	RCM4 = 0
TCM3 = 0	RCM3 = 1
TCM2 = 1	RCM2 = 1
TCM1 = 0	RCM1 = 1
TCM0 = 1	RCM0 = 0

9.9.11 Transmit Per-Channel Idle Code Insertion

Channel data can be replaced by an idle code on a per-channel basis in the transmit and receive directions.

The Transmit Idle Definition Registers ([TIDR1](#)-[TIDR32](#)) are provided to set the 8-bit idle code for each channel. The Transmit Channel Idle Code Enable registers ([TCICE1](#)-4) are used to enable idle code replacement on a per channel basis.

9.9.12 Receive Per-Channel Idle Code Insertion

Channel data can be replaced by an idle code on a per-channel basis in the transmit and receive directions. The Receive Idle Definition Registers ([RIDR1](#)-[RIDR32](#)) are provided to set the 8-bit idle code for each channel. The Receive Channel Idle Code Enable registers ([RCICE1](#)-4) are used to enable idle code replacement on a per-channel basis.

9.9.13 Per-Channel Loopback

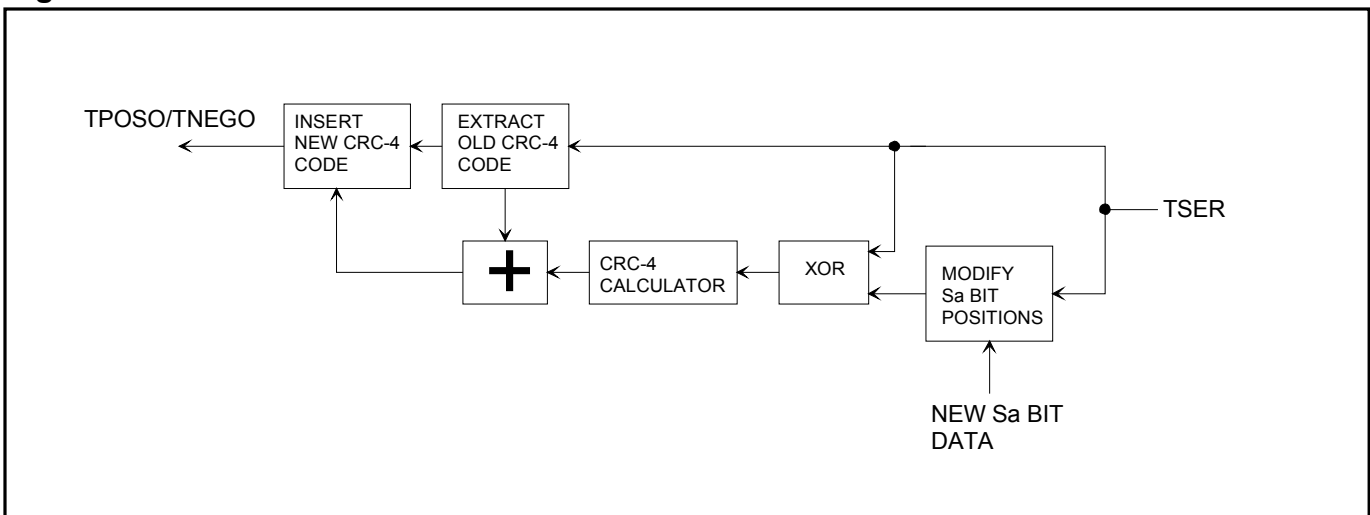
The Per-Channel Loopback Registers ([PCL1](#) to [PCL4](#)) determine which channels (if any) from the backplane should be replaced with the data from the receive side or in other words, off of the T1 or E1 line. If this loopback is enabled, then transmit and receive clocks and frame syncs must be synchronized. One method to accomplish this would be to tie RCLK to TCLK and RFSYNC to TSYNC. There are no restrictions on which channels can be looped back or on how many channels can be looped back.

Each of the bit positions in the Per-Channel Loopback Registers ([PCL1](#)/[PCLR2](#)/[PCLR3](#)/ [PCLR4](#)) represent a DS0 channel in the outgoing frame. When these bits are set to a one, data from the corresponding receive channel will replace the data on TSER for that channel.

9.9.14 E1 G.706 Intermediate CRC-4 Updating (E1 Mode Only)

The DS26528 can implement the G.706 CRC-4 recalculation at intermediate path points. When this mode is enabled, the data stream presented at TSER will already have the FAS/NFAS, CRC multiframe alignment word and CRC-4 checksum in time slot 0. The user can modify the Sa bit positions and this change in data content will be used to modify the CRC-4 checksum. This modification however will not corrupt any error information the original CRC-4 checksum may contain. In this mode of operation, TSYNC must be configured to multiframe mode. The data at TSER must be aligned to the TSYNC signal. If TSYNC is an input then the user must assert TSYNC aligned at the beginning of the multiframe relative to TSER. If TSYNC is an output, the user must multiframe align the data presented to TSER. This mode is enabled with the [TCR3.0](#) control bit (CRC4R). Note that the E1 transmitter must already be enabled for CRC insertion with the [TCR1.0](#) control bit (TCRC4).

Figure 9-8. CRC-4 Recalculate Method



9.9.15 T1 Programmable In-Band Loop Code Generator

The DS26528 can generate and detect a repeating bit pattern from one to eight bits or 16 bits in length. **This function is available only in T1 mode.**

Table 9-29. Registers Related to T1 In-Band Loop Code Generator

REGISTER	FRAMER 1 ADDRESSES	FUNCTION
T1TCD1	1AC	Pattern to be sent for Loop Code
T1TCD2	1AD	Length of the pattern to be sent
TCR3	183	TLOOP bit for control of number of patterns being sent
TCR4	186	Length of the code being sent

Note: The addresses shown above are for Framer 1. Addresses for Framers 2 – 8 can be calculated using the following: Framer N = (Framer 1 address + (n-1) x 200hex); where n = 2 to 8 for Framers 2 to 8.

To transmit a pattern, the user will load the pattern to be sent into the Transmit Code Definition registers (TCD1&TCD2) and select the proper length of the pattern by setting the TC0 and TC1 bits in Transmit Control Register 4 (TCR4). When generating a 1-, 2-, 4-, 8-, or 16-bit pattern both transmit code definition registers (TCD1&TCD2) must be filled with the proper code. Generation of a 3-, 5-, 6-, and 7-bit pattern only requires TCD1 to be filled. Once this is accomplished, the pattern will be transmitted as long as the TLOOP control bit (TCR3.0) is enabled. Normally (unless the transmit formatter is programmed to not insert the F-bit position) the framer will overwrite the repeating pattern once every 193 bits to allow the F-bit position to be sent.

As an example, to transmit the standard “loop up” code for Channel Service Units (CSUs), which is a repeating pattern of ...10000100001..., set TCD1 = 80h, TC0=0, TC1=0, and TCR3.0 = 1.

9.9.15.1 T1 Programmable In-Band Loop Code Detection

The DS26528 can generate and detect a repeating bit pattern from one to eight bits or 16 bits in length. **This function is available only in T1 mode.**

Table 9-30. Registers Related to T1 In-Band Loop Code Detection

REGISTERS RELATED T1 IN-BAND LOOP CODE DETECTION	FRAMER 1 ADDRESSES	FUNCTION
Receive In-Band Code Control Register (T1RIBCC)	82	Used for Selecting Length of Receive In-Band Loop Code Register
Receive Up Code Definition Register 1 (T1RUPCD1)	AC	Receive Up Code Definition Register 1
Receive Up Code Definition Register 2 (T1RUPCD2)	AD	Receive Up Code Definition Register 2
Receive Down Code Definition Register 1 (T1RDNCD1)	AE	Receive Down Code Definition Register 1
Receive Down Code Definition Register 2 (T1RDNCD2)	AF	Receive Up Code Definition Register 2
Receive Spare Code Register 1 (T1RSCD1)	9C	Receive Spare Code Register
Receive Spare Code Register 2 (T1RSCD2)	9D	Receive Spare Code Register
Receive Real-Time Status Register 3 (RRTS3)	B2	Real-Time Loop Code Detect
Receive Latched Status Register 3 (RLS3)	B3	Latched Loop Code Detect Bits
Receive Interrupt Mask Register 3 (RIM3)	B4	Mask for Latched Loop Code Detect Bits

Note: The addresses shown above are for Framer 1. Addresses for Framers 2 – 8 can be calculated using the following: Framer N = (Framer 1 address + (n-1) x 200hex); where n = 2 to 8 for Framers 2 to 8.

The framer has three programmable pattern detectors. Typically, two of the detectors are used for “loop up” and “loop down” code detection. The user will program the codes to be detected in the Receive Up Code Definition (RUPCD1 and RUPCD2) registers and the Receive Down Code Definition (RDNCD1 and RDNCD2) registers and the length of each pattern will be selected via the RIBCC register. There is a third detector (Spare) and it is defined and controlled via the RSPCD1/RSPCD2 and RSCC registers. When detecting a 16-bit pattern both receive code definition registers are used together to form a 16-bit register. For 8-bit patterns both receive code definition registers will be filled with the same value. Detection of a 1-, 2-, 3-, 4-, 5-, 6-, and 7-bit pattern only requires the first receive code definition register to be filled. The framer will detect repeating pattern codes in both framed and unframed circumstances with bit error rates as high as $10E-2$. The detectors are capable of handling both F-bit inserted and F-bit overwrite patterns. Writing the least significant byte of receive code definition register resets the integration period for that detector. The code detector has a nominal integration period of 48ms. Hence, after about 48ms of receiving a valid code, the proper status bit (LUP, LDN, and LSP) will be set to a one. Note that real-time status bits, as well as latched set and clear bits are available for LUP, LDN and LSP (RRTS3 and RLS3). Normally codes are sent for a period of 5 seconds. It is recommend that the software poll the framer every 50ms to 100ms until 5 seconds has elapsed to ensure that the code is continuously present.

9.9.16 Framer Payload Loopbacks

The framer, payload and remote loopbacks are controlled by [RCR3](#).

Table 9-31. Register Related to Framer Payload Loopbacks

RECEIVE CONTROL REGISTER 3 (RCR3)	FRAMER 1 ADDRESSES	FUNCTION
Framer Loopback	083	Transmit data output from the framer is looped back to the receiver
Payload Loopback	083	The 192-bit payload data is looped back to the Transmitter
Remote Loopback	083	Data recovered by the Receiver is looped back to the transmitter

Note: The addresses shown above are for Framer 1. Addresses for Framers 2 – 8 can be calculated using the following: Framer N = (Framer 1 address + (n-1) x 200hex); where n = 2 to 8 for Framers 2 to 8.

9.10 HDLC Controllers

9.10.1 Receive HDLC Controller

This device has an enhanced HDLC controller that can be mapped into a single time slot, or Sa4 to Sa8 bits (E1 Mode) or the FDL (T1 Mode). The HDLC controller has 64-byte FIFO buffer in both the transmit and receive paths. The user can select any specific bits within the time slot(s) to assign to the HDLC controller, as well as specific Sa bits (E1 Mode)

The HDLC controller performs all the necessary overhead for generating and receiving Performance Report Messages (PRM) as described in ANSI T1.403 and the messages as described in AT&T TR54016. The HDLC controller automatically generates and detects flags, generates and checks the CRC check sum, generates and detects abort sequences, stuffs and de-stuffs zeros, and byte aligns to the data stream. The 64-byte buffers in the HDLC controller are large enough to allow a full PRM to be received or transmitted without host intervention. The registers related to the HDLC are displayed in the following table.

REGISTER	FRAMER 1 ADDRESSES	FUNCTION
Receive HDLC Control Register (RHC)	010	Mapping of the HDLC to DS0 or FDL
Receive HDLC Bit Suppress Register (RHBSE)	011	Receive HDLC bit suppression Register
Receive HDLC FIFO Control (RHFC)	087	Determines the length of the Receive HDLC FIFO
Receive HDLC Packet Bytes Available Register (RHPBA)	0B5	Tells the user how many bytes are available in the Receive HDLC FIFO
Receive HDLC FIFO Register (RHF)	0B6	The actual FIFO data
Receive Real-Time Status Register 5 (RRTS5)	0B4	Indicates the FIFO status
Receive Latched Status Register 5 (RLS5)	094	Latched Status
Receive Interrupt Mask 5 (RIM5)	0A4	Interrupt Mask for interrupt generation for the Latched Status
Transmit HDLC Control 1 (THC1)	110	Misc Transmit HDLC Control
Transmit HDLC Bit Suppress (THBSE)	111	Transmit HDLC Bit Suppress for bits not to be used
Transmit HDLC Control 2 (THC2)	113	HDLC to DS0 channel selection and other control
Transmit HDLC FIFO Control (THFC)	187	Used to control the Transmit HDLC FIFO
Transmit HDLC Status (TRTS2)	1B1	Indicates the Real-Time Status of the Transmit HDLC FIFO
Transmit HDLC Latched Status (TLS2)	191	Indicates the FIFO status
Transmit Interrupt Mask Register 2 (TIM2)	1A1	Interrupt Mask for the Latched Status
Transmit HDLC FIFO Buffer Available (TFBA)	1B3	Indicates the number of bytes that can be written into the Transmit FIFO
Transmit HDLC FIFO (THF)	1B4	Transmit HDLC FIFO

Note: The addresses shown above are for Framer 1. Addresses for Framers 2 – 8 can be calculated using the following: Framer N = (Framer 1 address + (n-1) x 200hex); where n = 2 to 8 for Framers 2 to 8.

9.10.1.1 HDLC FIFO Control

Control of the transmit and receive FIFOs is accomplished via the Receive HDLC FIFO Control ([RHFC](#)) and Transmit HDLC FIFO Control ([THFC](#)) registers. The FIFO Control registers set the watermarks for the FIFO.

When the receive FIFO fills above the high watermark, the RHWB bit ([RRTS5.1](#)) will be set. RHWB and THRM are real-time bits and will remain set as long as the FIFO's write pointer is above the watermark. When the transmit FIFO empties below the low watermark, the TLWB bit in the [TRTS2](#) register will be set. TLWB is a real-time bit

and will remain set as long as the transmit FIFO's write pointer is below the watermark. If enabled, this condition can also cause an interrupt via the INTB pin.

If the receive HDLC FIFO does overrun the current packet being processed is dropped. The receive FIFO is emptied. The packet status bit in [RRTS5](#) and [RLS5](#).5 (ROVR) indicate an overrun.

9.10.1.2 Receive Packet Bytes Available

The lower 7 bits of the Receive Packet Bytes Available register indicates the number of bytes (0 through 64) that can be read from the receive FIFO. The value indicated by this register informs the host as to how many bytes can be read from the receive FIFO without going past the end of a message. This value will refer to one of four possibilities, the first part of a packet, the continuation of a packet, the last part of a packet, or a complete packet. After reading the number of bytes indicated by this register the host then checks the HDLC Status registers for detailed message status.

If the value in the [RHPBA](#) register refers to the beginning portion of a message or continuation of a message then the MSB of the RHPBA register will return a value of 1. This indicates that the host may safely read the number of bytes returned by the lower 7 bits of the RHPBA register but there is no need to check the information register since the packet has not yet terminated (successfully or otherwise).

9.10.1.3 HDLC Status And Information

[RRTS5](#), [RLS5](#), and [TLS2](#) provide status information for the HDLC controller. When a particular event has occurred (or is occurring), the appropriate bit in one of these registers will be set to a one. Some of the bits in these registers are latched and some are real-time bits that are not latched. This section contains register descriptions that list which bits are latched and which are real-time. With the latched bits, when an event occurs and a bit is set to a one, it will remain set until the user reads and clears that bit. The bit will be cleared when a '1' is written to the bit and it will not be set again until the event has occurred again. The real-time bits report the current instantaneous conditions that are occurring and the history of these bits is not latched.

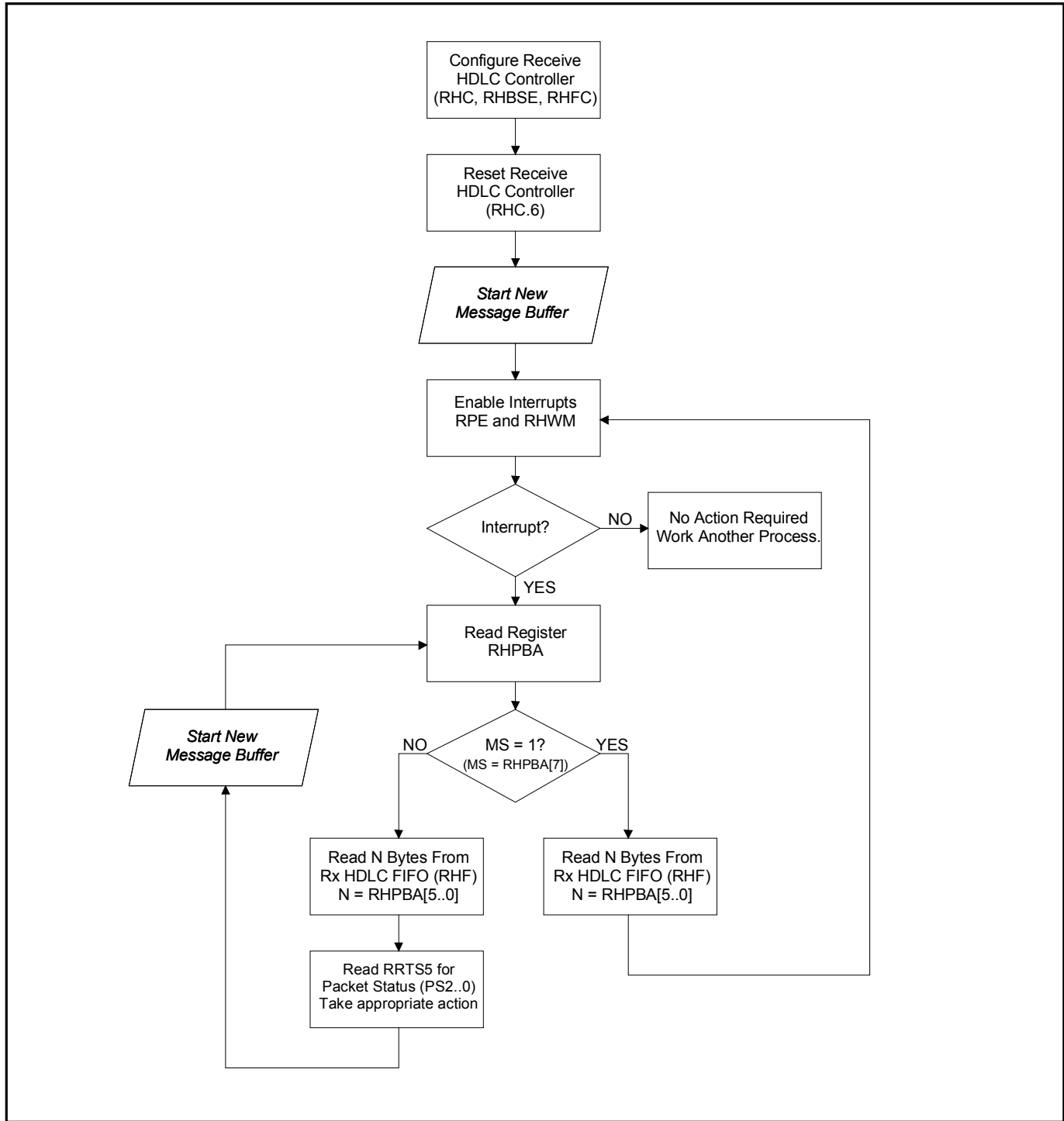
Like the other latched status registers, the user will follow a read of the status bit with a write. The byte written to the register will inform the device which of the latched bits the user wishes to clear (the real-time bits are not affected by writing to the status register). The user will write a byte to one of these registers, with a one in the bit positions he or she wishes to clear and a zero in the bit positions he or she does not wish to clear.

The HDLC status registers [RLS5](#) and [TLS2](#) have the ability to initiate a hardware interrupt via the INTB output signal. Each of the events in this register can be either masked or unmasked from the interrupt pin via the HDLC Interrupt Mask Registers [RIM5](#) and [TIM2](#). Interrupts will force the INTB signal low when the event occurs. The INTB pin will be allowed to return high (if no other interrupts are present) when the user reads the event bit that caused the interrupt to occur.

9.10.1.4 HDLC Receive Example

The HDLC status registers in the DS26528 allow for flexible software interface to meet the user's preferences. When receiving HDLC messages, the host can chose to be interrupt driven, or to poll to desired status registers, or a combination of polling and interrupt processes may be used. An example routine for using the DS26528 HDLC receiver is given in the following figure.

Figure 9-9. Receive HDLC Example



9.10.2 Transmit HDLC Controller

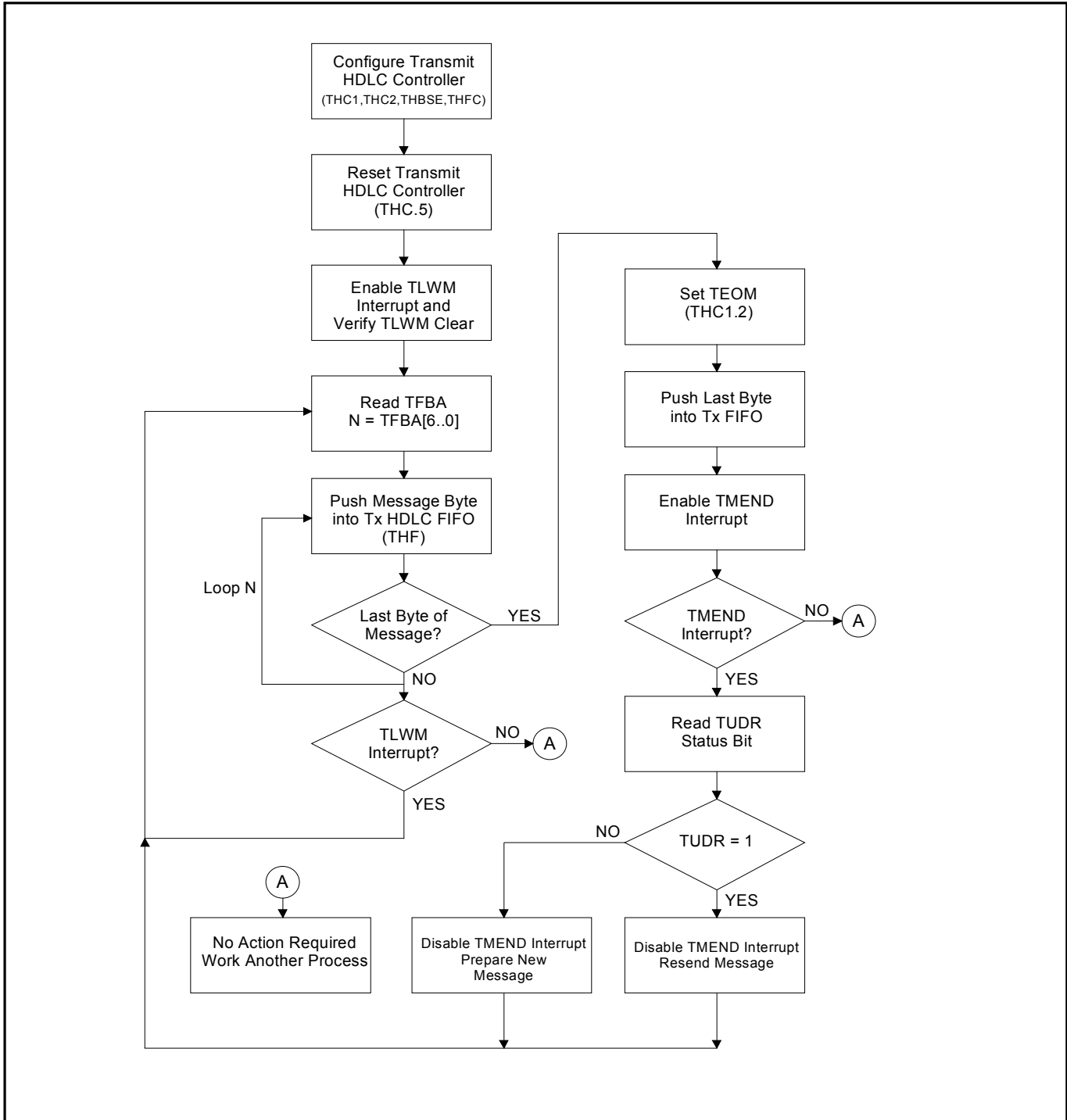
9.10.3 FIFO Information

The Transmit FIFO Buffer Available register ([TFBA](#)) indicates the number of bytes that can be written into the transmit FIFO. The count from this register informs the host as to how many bytes can be written into the transmit FIFO without overflowing the buffer. This is a real-time register. The count shall remain valid and stable during the read cycle.

9.10.4 HDLC Transmit Example

The HDLC status registers in the DS26528 allow for flexible software interface to meet the user's preferences. When transmitting HDLC messages, the host can choose to be interrupt driven, or to poll to desired status registers, or a combination of polling and interrupt processes may be used. An example routine for using the DS26528 HDLC receiver is given in the following figure.

Figure 9-10. HDLC Message Transmit Example



9.11 Line Interface Units (LIU)

The DS26528 has eight identical LIU transmit and receive front ends for each of the eight framers. Each LIU contains three sections: the transmitter, which waveshapes and drives the network line; the receiver, which handles clock and data recovery; and the jitter attenuator. The DS26528 LIUs can switch between T1 or E1 networks without changing any external components on either the transmit or receive side. [Figure 9-11](#) shows basic balanced network connections using minimal components. In this configuration the device can connect to 100 Ω T1 twisted pair, 110 Ω J1 twisted pair, 75 Ω or 120 Ω E1 twisted pair without additional component changes. Other components may be added to this configuration in order to meet safety and network protection requirements. The signals between the framer and LIU are not accessible by the user, thus the framer and LIU cannot be separated. The transmitters have fast High-Z capability and can be individually powered down.

The DS26528's transmit waveforms meet the corresponding G.703 and T1.102 specifications. Internal software-selectable transmit termination is provided for 100 Ω T1 twisted pair, 110 Ω J1 twisted pair, 120 Ω E1 twisted pair and 75 Ω E1 coaxial applications. The receiver can connect to 100 Ω T1 twisted pair, 110 Ω J1 twisted pair, 120 Ω E1 twisted pair, and 75 Ω E1 coaxial. The receive LIU can function with a receive signal attenuation of up to 36dB for T1 mode and 43dB for E1 mode. The receiver sensitivity is programmable from 12dB to 43dB of cable loss. Also a monitor gain setting can be enabled to provide 14, 20, 26 and 32dB of resistive gain.

Figure 9-11. Basic Balanced Network Connections

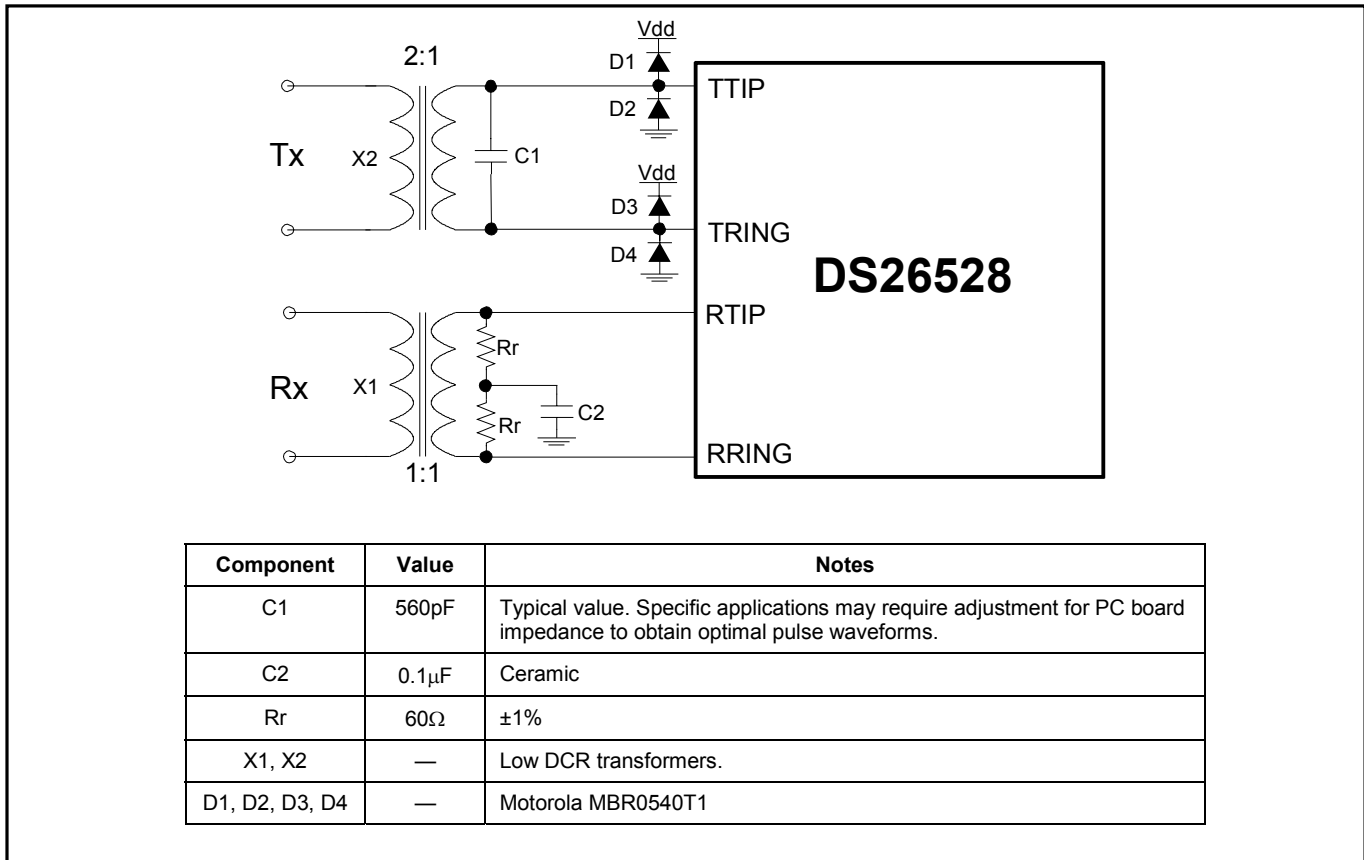


Figure 9-12. Recommended Supply Decoupling

SUPPLY PINS	DECOUPLING CAPACITANCE	NOTES
DVDD / DVSS	0.1 μ F + 0.1 μ F + 1 μ F + 10 μ F	
DVDDIO / DVSSIO	0.1 μ F + 0.1 μ F + 1 μ F + 10 μ F	
ATVDD / ATVSS	(0.1 μ F + 1 μ F + 10 μ F) x 4	Place set of three capacitors on each side of the device.
ARVDD / ARVSS	(0.1 μ F + 1 μ F + 10 μ F) x 4	Place set of three capacitors on each side of the device.
ACVDD / ACVSS	0.1 μ F + 1 μ F + 10 μ F	

9.11.1 LIU Operation

The analog AMI/HDB3 waveforms off of the E1 lines or the AMI/B8ZS waveform off of the T1 lines are transformer coupled into the RTIP and RRING pins of the DS26528. The user has the option to use internal termination, software selectable for 75 Ω /100 Ω /110 Ω /120 Ω applications, or external termination. The LIU recovers clock and data from the analog signal and passes it through the jitter attenuation mux. The DS26528 contains an active filter that reconstructs the analog received signal for the nonlinear losses that occur in transmission. The receive circuitry also is configurable for various monitor applications. The device has a usable receive sensitivity of 0dB to -43dB for E1 and 0dB to -36dB for T1, which allows the device to operate on 0.63mm (22AWG) cables up to 2.5km (E1) and 6k feet (T1) in length. Data input to the transmit side of the LIU is sent via the jitter attenuation MUX to the wave shaping circuitry and line driver. The DS26528 will drive the E1 or T1 line from the TTIP and TRING pins via a coupling transformer. The line driver can handle both CEPT 30/ISDN-PRI lines for E1 and long-haul (CSU) or short-haul (DSX-1) lines for T1. The registers that control the LIU operation are shown in [Table 9-32](#).

Table 9-32. Registers Related to Control of DS26528 LIU

REGISTER	ADDRESS (HEX)	FUNCTION
GTCR2 - Global Transceiver Control Register 2	00F2	Global Transceiver Control
GTCCR Global Transceiver Clock Control Register	00F3	MPS Selections, Backplane Clock Selections
GLSRR Global LIU Reset Register Control	00F5	Software reset control for the LIU
GLISR Global LIU Interrupt Status Register	00FB	Interrupt Status bit for each of the 8 LIUs
GLIMR Global LIU Interrupt Mask Register	00FE	Interrupt Mask Register for the LIU
LTRCR LIU Transmit Receive Control Register	1000, 1020, 1040, 1060, 1080, 10A0, 10C0, 10E0	T1J1 E1 selection, Output Tri-state, Loss Criteria
LTITSR LIU Transmit Impedance Selection Register	1001, 1021, 1041, 1061, 1081, 10A1, 10C1, 10E1	Transmit Pulse Shape and Impedance Selection
LMCR LIU Maintenance Register	1002, 1022, 1042, 1062, 1082, 10A2, 10C2, 10E2	Trans Maintenance and Jitter Attenuation Control Register
LRSR LIU Real Status Register	1003, 1023, 1043, 1063, 1083, 10A3, 10C3, 10E3	LIU Real-Time Status Register
LSIMR LIU Status Interrupt Mask Register	1004, 1024, 1044, 1064, 1084, 10A4, 10C4, 10E4	LIU Mask Registers based on Latched Status Bits
LLSR LIU Latched Status Register	1005, 1025, 1045, 1065, 1085, 10A5, 10C5, 10E5	LIU latched status bits related to loss, Open circuit, etc.
LRSL LIU Receive Signal Level	1006, 1026, 1046, 1066, 1086, 10A6, 10C6, 10E6	LIU Receive Signal Level Indicator
LRISMR LIU Receive Impedance and Sensitivity Monitor Register	1007, 1027, 1047, 1067, 1087, 10A7, 10C7, 10E7	LIU Impedance Match and Sensitivity Monitor

9.11.2 Transmitter

NRZ data arrives from the framer transmitter; the data is encoded with HDB3 or B8ZS or AMI. The encoded data passes through a jitter attenuator if it is enabled for the transmit path. A digital sequencer and DAC are used to generate transmit waveforms compliant with T1.102 and G.703 pulse templates.

A line driver is used to drive an internal matched impedance circuit for provision of 75 Ω , 100 Ω , 110 Ω , and 120 Ω terminations. The transmitter couples to the E1 or T1 transmit twisted pair (or coaxial cable in some E1 applications) via a 1:2 step-up transformer. In order for the device to create the proper waveforms, the transformer used must meet the specifications listed in [Table 9-34](#). The transmitter requires a transmit clock of 2.048MHz for E1 or 1.544MHz for T1/J1 operation.

The DS26528 drivers have a short circuit and open circuit detection driver fail monitor. There is a TXEnable pin that can High-Z the transmitter outputs for protection switching. The individual transmitters can also be placed in High-Z through register settings. The DS26528 also has functionality for powering down the transmitters individually. The relevant telecommunications specification compliance is shown in [Table 9-33](#).

Table 9-33. The Telecommunications Specification Compliance for DS26528 Transmitters

TRANSMITTER FUNCTION	TELECOMMUNICATIONS COMPLIANCE
T1 Telecom Pulse Template Compliance	ANSI T1.403
T1 Telecom Pulse Template Compliance	ANSI T1.102
Transmit Electrical Characteristics for E1 Transmission and Return Loss Compliance	ITU G.703

Table 9-34. Transformer Specifications

SPECIFICATION	RECOMMENDED VALUE
Turns Ratio 3.3V Applications	1:1 (receive) and 1:2 (transmit) $\pm 2\%$
Primary Inductance	600 μ H minimum
Leakage Inductance	1.0 μ H maximum
Intertwining Capacitance	40pF maximum
Transmit Transformer DC Resistance Primary (Device Side) Secondary	1.0 Ω maximum 2.0 Ω maximum
Receive Transformer DC Resistance Primary (Device Side) Secondary	1.2 Ω maximum 1.2 Ω maximum

9.11.2.1 Transmit Line Pulse Shapes

The DS26528 transmitters can be selected individually to meet the pulse templates for E1 and T1/J1 modes. The T1/J1 pulse template is shown in [Figure 9-13](#). The E1 pulse template is shown in [Figure 9-14](#). The transmit pulse shape can be configured for each LIU on an individual basis. The LIU transmit impedance selection registers can be used to select an internal transmit terminating impedance of 100Ω for T1, 110Ω for J1 mode, 75Ω or 120Ω for E1 mode or no internal termination for E1 or T1 mode. The transmit pulse shape and terminating impedance is selected by [LTITSR](#) registers. The pulse shapes will be compliant to T1.102 and G.703. Pulse shapes are measured for compliance at the appropriate network interface (NI). For T1 long haul and E1, the pulse shape is measured at the far end. For T1 short haul, the pulse shape is measured at the near end.

Figure 9-13. T1/J1 Transmit Pulse Templates

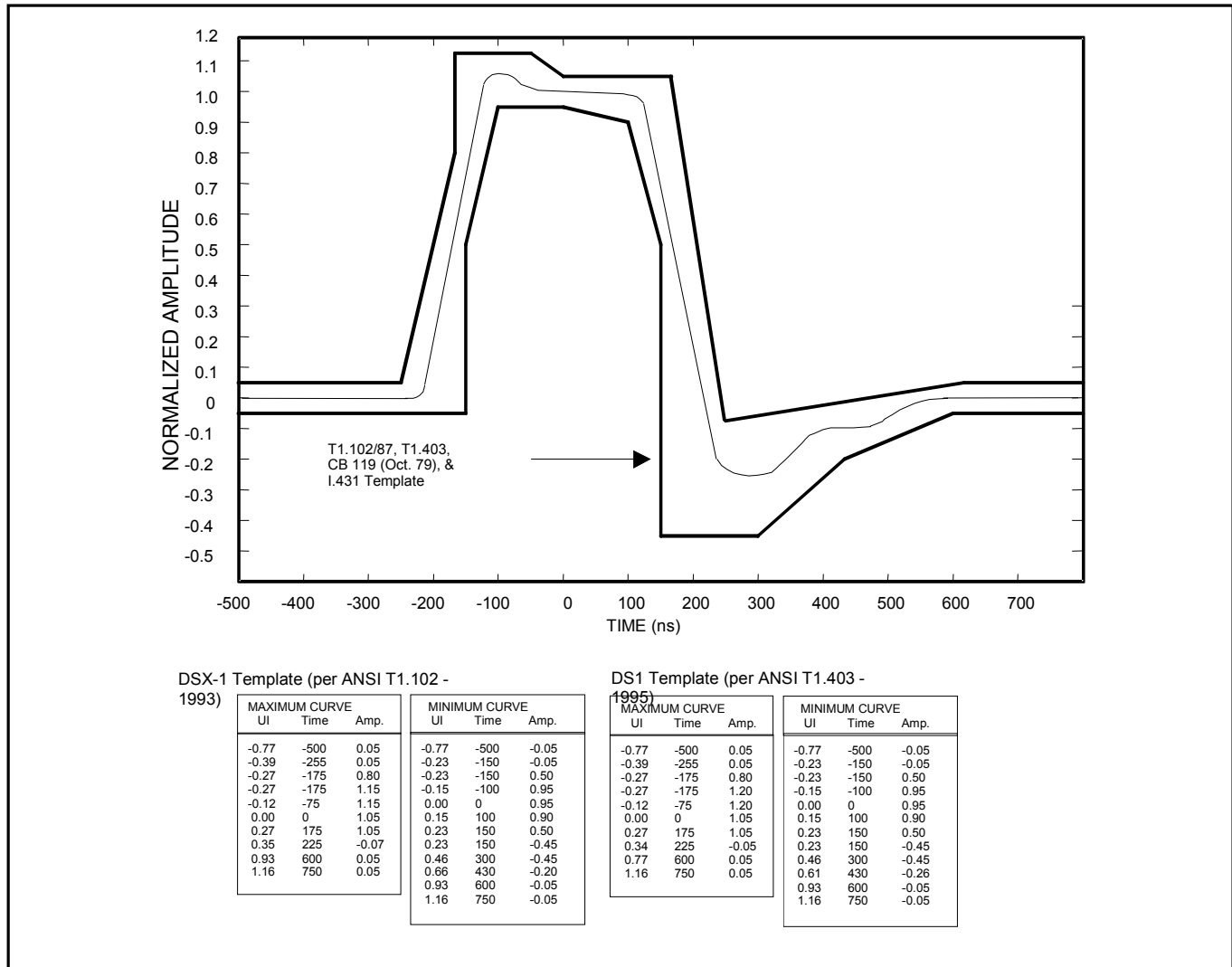
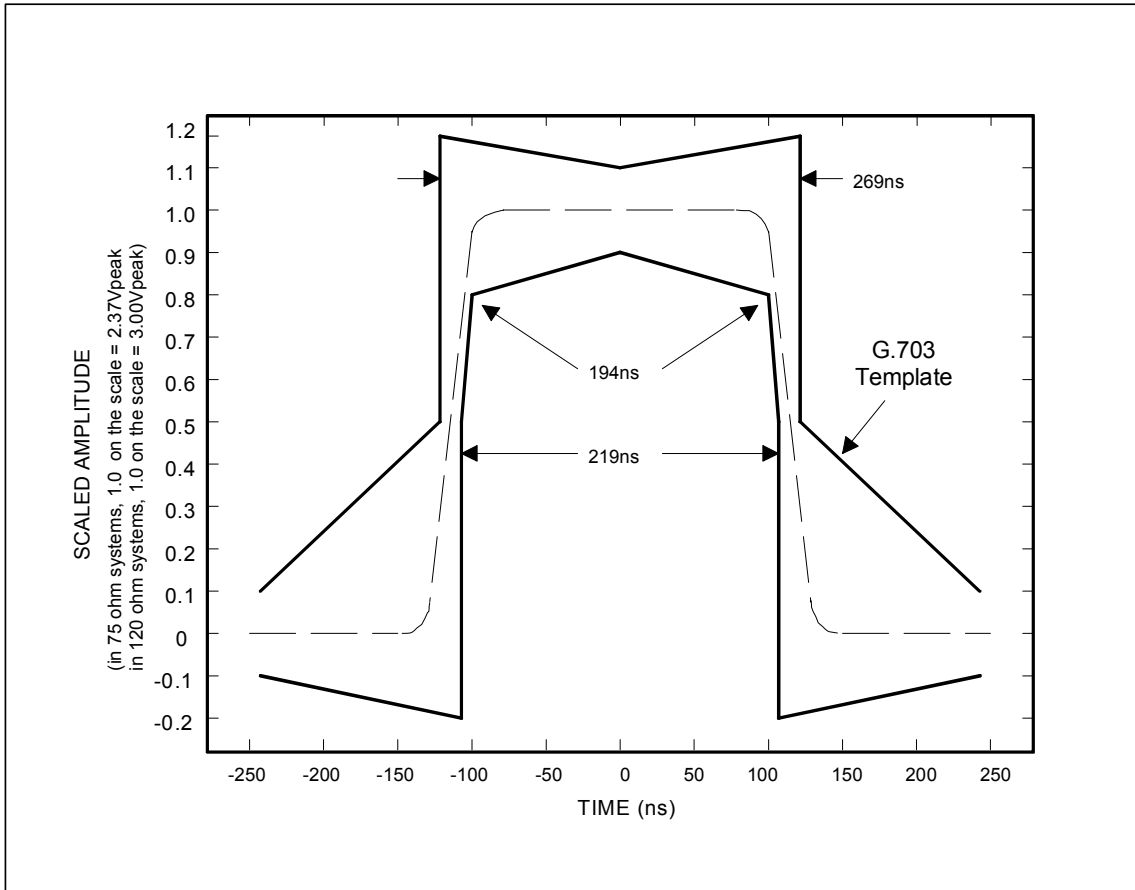


Figure 9-14. E1 Transmit Pulse Templates

9.11.2.2 Transmit Power-Down

The individual transmitters can be powered down by setting the TPDE bit in the LIU maintenance control register ([LMCR](#)). Note that powering down the transmit LIU results in a High-Z state for the corresponding TTIP and TRING pins.

When Transmit all ones (AIS) is invoked, continuous ones are transmitted using MCLK as the timing reference. Data input from the framer is ignored. AIS can be sent by setting a bit in the LIU maintenance control register ([LMCR](#)). Transmit all ones will also be sent if the corresponding receiver goes into LOS state and the ATAIS bit is set in the LIU maintenance control register.

9.11.2.3 Transmit Short-Circuit Detector/Limiter

Each transmitter has an automatic short-circuit current limiter that activates when the load resistance is approximately 25Ω or less. SCS ([LRSR](#)) provides a real-time indication of when the current limiter is activated. LIU Latched Status Register ([LLSR](#)) provides a latched versions of the information, which can be used to activate an interrupt when enable via the [LSIMR](#) register.

9.11.2.4 Transmit Open-Circuit Detector

The DS26528 can also detect when the TTIP or TRING outputs are open circuited. OCS ([LRSR](#)) will provide a real-time indication of when an open circuit is detected. Register [LLSR](#) provides latched versions of the information, which can be used to activate an interrupt when enabled via the [LSIMR](#) register.

9.11.3 Receiver

The DS26528 contains eight identical receivers. All receivers are designed to be fully software-selectable for E1, T1, and J1 without the need to change any external resistors. The device couples to the receive E1 or T1 twisted pair (or coaxial cable in 75Ω E1 applications) via a 1:1 or 2:1 transformer. See [Table 9-34](#) for transformer details. Receive termination and sensitivity are user configurable. Receive termination is configurable for 75Ω, 100Ω, 110Ω, or 120Ω termination by setting the appropriate RIMPM[1:0] bits ([LRISMR](#)). When using the internal termination feature, the resistors labeled Rr in [Figure 9-11](#) should be 60Ω each. If external termination is required, the resistors will need to be 37.5Ω, 50Ω, or 60Ω each depending on the line impedance. Receive sensitivity is configurable by setting the appropriate RSMS[1:0] bits ([LRISMR](#)).

The DS26528 uses a digital clock recovery system. The resultant E1, T1 or J1 clock derived from MCLK is multiplied by 16 via an internal PLL and fed to the clock recovery system. The clock recovery system uses the clock from the PLL circuit to form a 16 times over-sampler, which is used to recover the clock and data. This over-sampling technique offers outstanding performance to meet jitter tolerance specifications shown in [Table 9-16](#).

Normally, the clock that is output at the RCLK pin is the recovered clock from the E1 AMI/HDB3 or T1 AMI/B8ZS waveform presented at the RTIP and RRING inputs. If the jitter attenuator ([LTRCR](#)) is placed in the receive path (as is the case in most applications), the jitter attenuator restores the RCLK to an approximate 50% duty cycle. If the jitter attenuator is either placed in the transmit path or is disabled, the RCLK output can exhibit slightly shorter high cycles of the clock. This is due to the highly over-sampled digital clock recovery circuitry. See the [Receiver AC Characteristics](#) section for more details. When no signal is present at RTIP and RRING, a receive carrier loss (RCL) condition will occur and the RCLK will be derived from the JACLK source

9.11.3.1 Receive Level Indicator

The DS26528 will report the signal strength at RTIP and RRING in approximately 2.5dB increments via RSL3-RSL0 located in the LIU receive signal level register ([LRSL](#)). This feature is helpful when trouble shooting line performance problems.

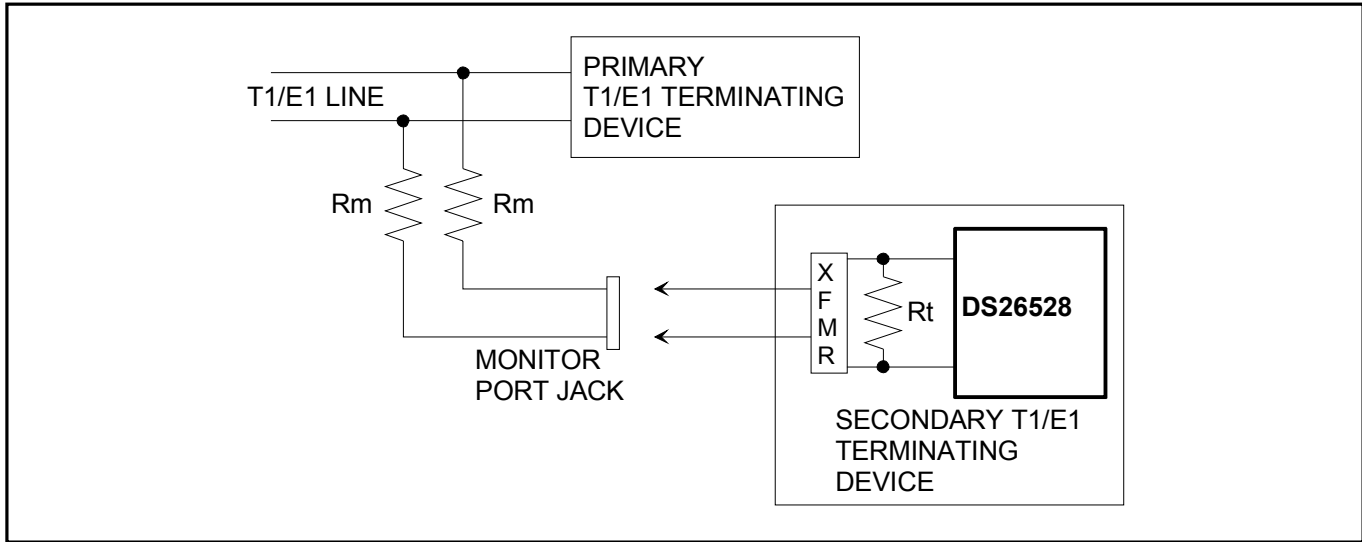
9.11.3.2 Receive G.703 Section 10 Synchronization Signal

The DS26528 is capable of receiving a 2.048MHz square-wave synchronization clock as specified in Section 10 of ITU G.703. In order to use this mode, set the Receive G.703 Clock Enable found in LIU Receive Impedance and Sensitivity Monitor Register ([LRISMR](#)).

9.11.3.3 Receiver Monitor Mode

The receive equalizer is equipped with a monitor mode function that is used to overcome the signal attenuation caused by the resistive bridge used in monitoring applications. This function allows for a resistive gain of up to 32dB along with cable attenuation of 12dB to 30dB as shown in LIU Receive Impedance and Sensitivity Monitor Register ([LRISMR](#)).

Figure 9-15. Typical Monitor Application



9.11.3.4 Loss of Signal

The DS26528 uses both the digital and analog loss detection method in compliance with the latest T1.231 for T1/J1 and ITU G.775 or ETSI 300 233 for E1 mode of operation.

LOS is detected if the receiver level falls below a threshold analog voltage for certain duration. Alternatively, this can be termed as having received “zeros” for a certain duration. The signal level and timing duration are defined in accordance with the T1.231 or G.775 or ETSI 300 233 specifications.

For short haul mode, the loss detection thresholds are based on cable loss of 12dB to 18dB for both T1/J1 and E1 modes. The loss thresholds are selectable based on [Table 10-18](#). For long-haul mode, the LOS Detection threshold is based on cable loss of 30dB to 38dB for T1/J1 and 30dB to 45dB for E1 mode. Note there is no explicit bit called short haul mode selection. Loss declaration level is set at 3dB lower than the maximum sensitivity setting programmed in [Table 10-18](#).

The loss state is exited when the receiver detects a certain ones density at the maximum sensitivity level or higher, which is 3dB higher than the loss detection level. The loss detection signal level and loss reset signal level are defined with hysteresis to prevent the receiver from bouncing between “LOS” and “no LOS” states. [Table 9-35](#) outlines the specifications governing the loss function.

Table 9-35. T1.231, G.775, and ETSI 300 233 Loss Criteria Specifications

CRITERIA	STANDARD		
	T1.231	ITU G.775	ETSI 300 233
Loss Detection	No pulses are detected for 175 ±75 bits.	No pulses are detected for duration of 10 to 255 bit periods.	No pulses are detected for a duration of 2048 bit periods or 1ms
Loss Reset	Loss is terminated if a duration of 12.5% ones are detected over duration of 175 ±75 bits. Loss is not terminated if 8 consecutive zeros are found if B8ZS encoding is used. If B8ZS is not used loss is not terminated if 100 consecutive pulses are zero.	The incoming signal has transitions for duration of 10 to 255 bit periods.	Loss reset criteria is not defined.

9.11.3.5 ANSI T1.231 for T1 and J1 Modes

For short haul mode, loss is declared if the received signal level is 3dB lower from the programmed value (based on [Table 10-18](#)) for a duration of 192-bit periods. Hence if the sensitivity is programmed to be 12dB, loss will be declared at 15dB.

LOS is reset if all of the following criteria are met:

- 24 or more ones are detected in 192-bit period with a programmed sensitivity level measured at RTIP and RRING.
- During the 192 bits less than 100 consecutive zeros are detected.

For long haul mode, loss is detected if the received signal level is 3dB lower from the programmed value (based on [Table 10-18](#)) for a duration of 192-bit periods. Hence, if the sensitivity is programmed at 30dB, loss declaration level will be 33dB.

LOS is reset if all of the following criteria are met:

- 24 or more ones are detected in 192-bit period with a programmed sensitivity level measured at RTIP and RRING.
- During the 192 bits less than 100 consecutive zeros are detected.

9.11.3.6 ITU G.775 for E1 Modes

For short haul mode, loss is declared if the received signal level is 3dB lower from the programmed value (based on [Table 10-18](#)) for a duration of 192-bit periods. Hence, if the sensitivity is programmed to be 12dB, loss will be declared at 15dB.

LOS is reset if the receive signal level is greater than or equal to the programmed sensitivity level for a duration of 192-bit periods.

For long haul mode, loss is detected if the received signal level is 3dB lower from the programmed value (based on [Table 10-18](#)) for a duration of 192-bit periods. Hence, if the sensitivity is programmed at 30dB, loss declaration level will be 33dB.

LOS is reset if the receive signal level is greater than or equal to the programmed sensitivity level for a duration of 192-bit periods.

9.11.3.7 ETSI 200 233 for E1 Modes

For short haul mode, loss is declared if the received signal level is 3dB lower from the programmed value (based on [Table 10-18](#)) continuous duration of 2048-bit periods (1ms). LOS is reset if the receive signal level is greater than or equal to programmed sensitivity level for a duration of 192-bit periods.

For long haul mode, loss is declared if the received signal level is 3dB lower from the programmed value (based on [Table 10-18](#)) continuous duration of 2048 bit periods (1ms). LOS is reset if the receive signal level is greater than or equal to the programmed sensitivity level for a duration of 192-bit periods.

9.11.4 Jitter Attenuator

The DS26528 contains a jitter attenuator that can be set to a depth of 32 or 128-bits via the JADS bit in LIU Transmit and Receive Control Register ([LTRCR](#)).

The 128-bit mode is used in applications where large excursions of wander are expected. The 32-bit mode is used in delay sensitive applications. The characteristics of the attenuation are shown in [Figure 9-16](#). The jitter attenuator can be placed in either the receive path, the transmit path or disabled by appropriately setting the JAPS1 and JAPS0 bits in LIU Transmit and Receive Control Register ([LTRCR](#)).

For the jitter attenuator to operate properly, a 2.048MHz, 1.544MHz, or a multiple of up to 8x clock must be applied at MCLK. See the Global Transceiver Clock Control Register ([GTCCR](#)) for MCLK options. ITU specification G.703 requires an accuracy of ± 50 ppm for both T1/J1 and E1 applications. TR62411 and ANSI specs require an accuracy of ± 32 ppm for T1/J1 interfaces. Circuitry adjusts either the recovered clock from the clock/data recovery block or the clock applied at the TCLK pin to create a smooth jitter-free clock, which is used to clock data out of the jitter attenuator FIFO. It is acceptable to provide a gapped/bursty clock at the TCLK pin if the jitter attenuator is placed in

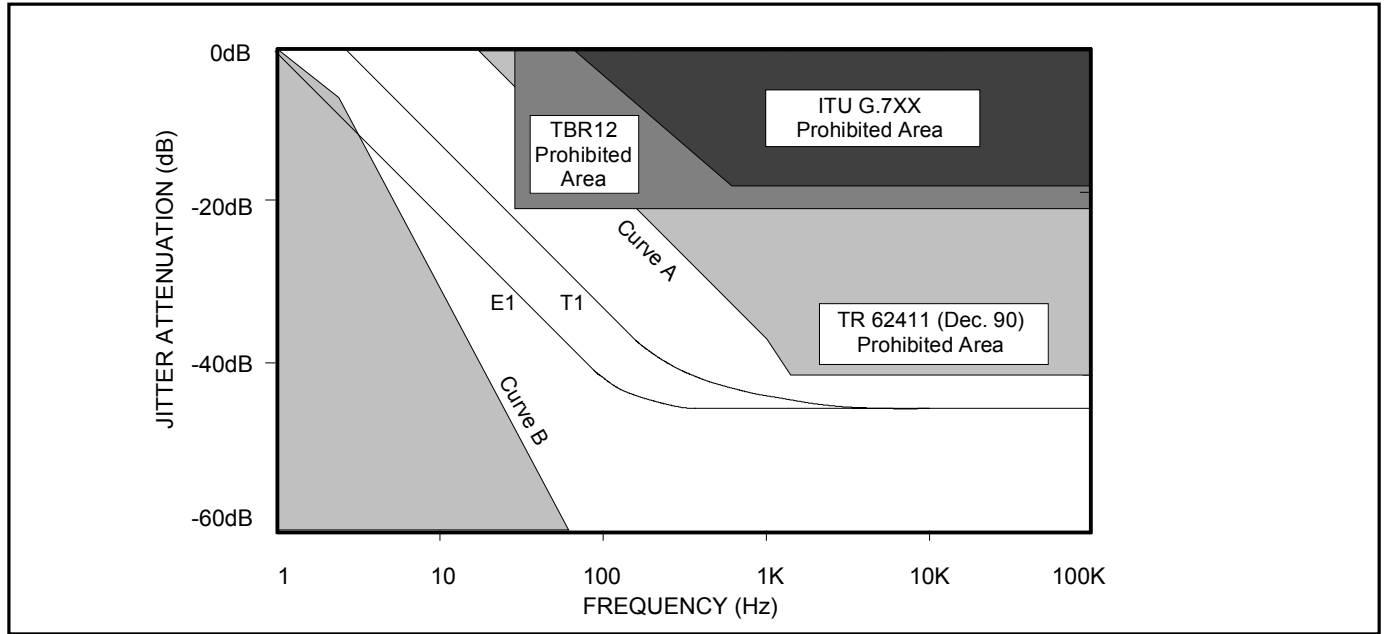
the transmit side. If the incoming jitter exceeds either $120U_{I_{P-P}}$ (buffer depth is 128-bits) or $28U_{I_{P-P}}$ (buffer depth is 32 bits), then the DS26528 will set the jitter attenuator limit trip (JALTS) bit in the LIU latched status register ([LLSR](#)). In T1/J1 mode, the jitter attenuator corner frequency is 3.75Hz and in E1 Mode it is 0.6Hz.

The DS26528 jitter attenuator is compliant with the following specifications:

Table 9-36. Jitter Attenuator Standards Compliance

Standard
ITU-T I.431, G.703, G.736, G.823,
ETSI 300011, TBR 12/12
AT&T TR62411, TR43802
TR-TSY 009, TR-TSY 253, TR-TSY 499

Figure 9-16. Jitter Attenuation



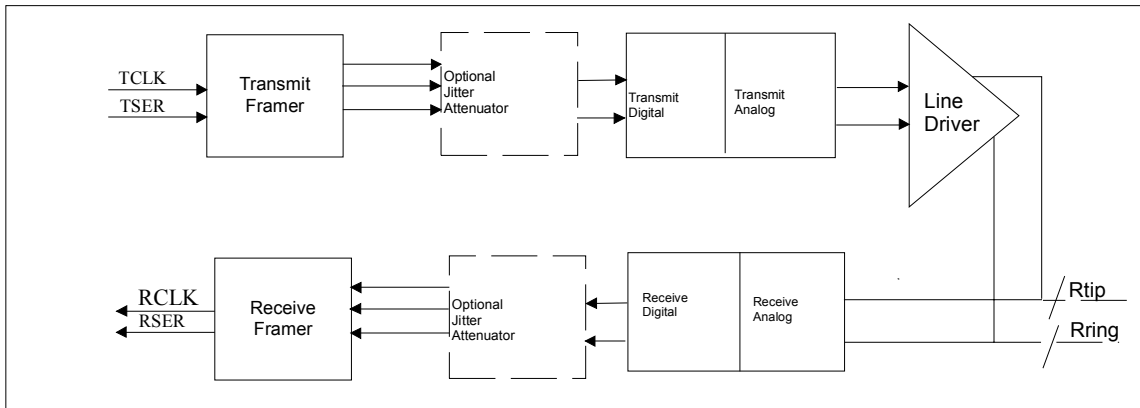
9.11.5 LIU Loopbacks

The DS26528 provides four LIU loopbacks for diagnostic purposes: analog loopback, local loopback, remote loopback and dual loopback. In the “loopback diagrams” that follow, the TSER, TCLK and RSER and RCLK are inputs/outputs from the framer. Note that the framer input/output can be in IBO mode where a single TSER/RSER can be shared by up to eight framers.

9.11.5.1 Analog Loopback

The analog output of the transmitter TTIP and TRING is looped back to RTIP and RRING of the receiver. Data at RTIP and RRING is ignored in analog loopback. This is shown in the following figure.

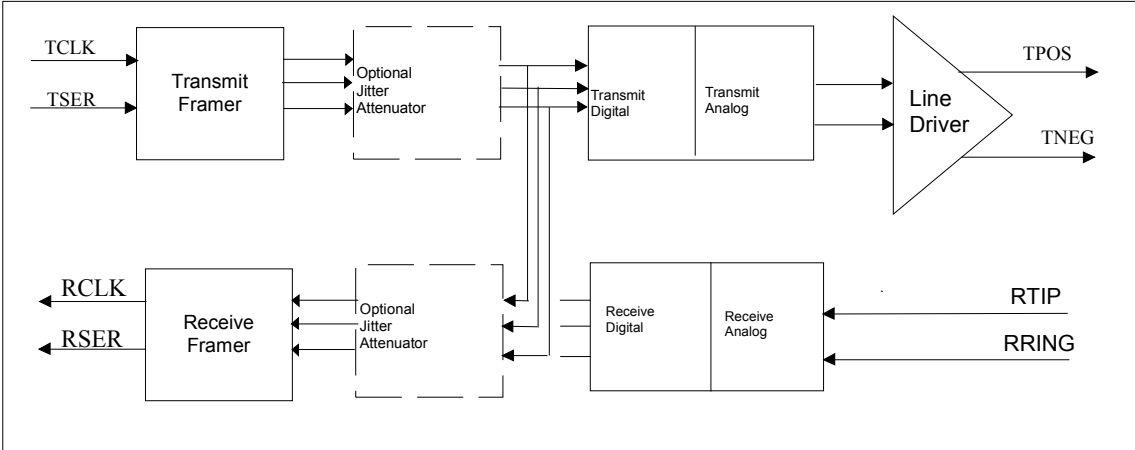
Figure 9-17. Analog Loopback



9.11.5.2 Local Loopback

The transmit system data TPOS and TNEG and TCLK will be looped back to output on RCLK, RPOS and RNEG. The data input at TPOS and TNEG will encode and output on TTIP and TRING. Signals at RTIP and RRING will be ignored. This loopback is conceptually shown in following figure.

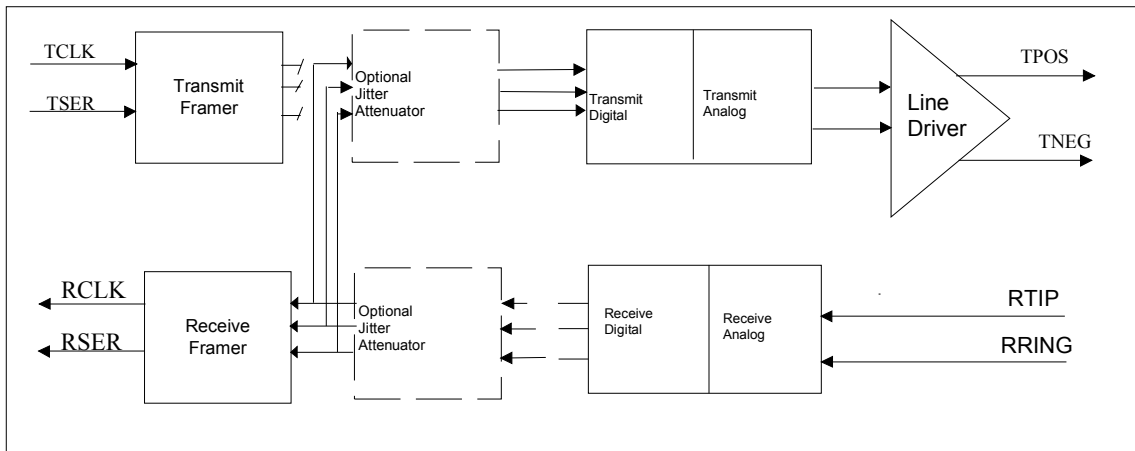
Figure 9-18. Local Loopback



9.11.5.3 Remote Loopback

The outputs decoded from the receive LIU are looped back to the transmit LIU. The inputs from the transmit framer are ignored during a remote loopback. This loopback is conceptually shown in [Figure 9-19](#).

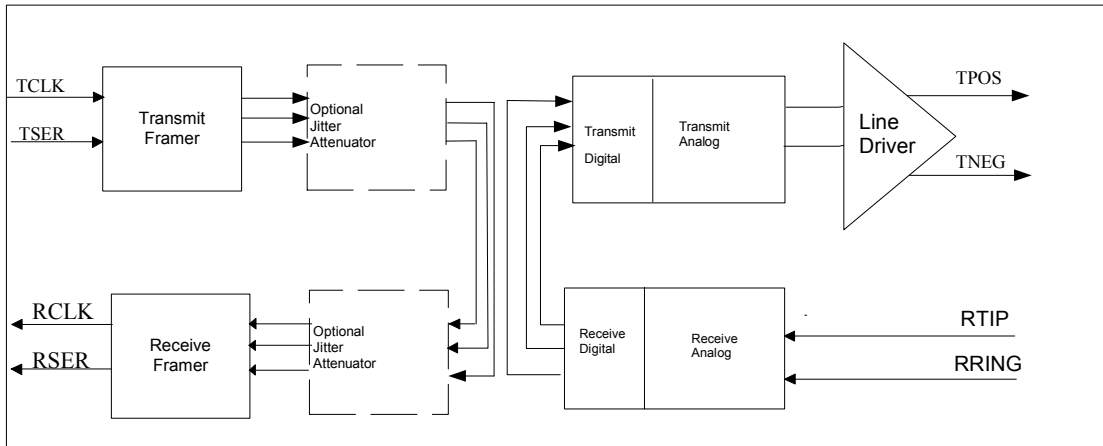
Figure 9-19. Remote Loopback



9.11.5.4 Dual Loopback

The inputs decoded from the receive LIU are looped back to the transmit LIU. The inputs from the transmit framer are looped back to the receiver with the optional jitter attenuator. This loopback is invoked if RLB and LLB are both set in the LIU Maintenance Control Register ([LMCR](#)). This loopback is conceptually shown in [Figure 9-20](#).

Figure 9-20. Dual Loopback



9.12 Bit Error Rate Test Function (BERT)

The BERT (Bit Error Rate Tester) block can generate and detect both pseudo-random and repeating-bit patterns. It is used to test and stress data-communication links. BERT functionality is dedicated for each of the Transceivers. The registers related to the configure, control and status of the BERT are shown in the following table:

REGISTER	FRAMER 1 ADDRESSES	FUNCTION
GBISR	0FA	Global BERT Interrupt Register. When any of the 8 BERTs issue an interrupt, a bit will be set.
GBIMR	0FD	Global BERT Interrupt Mask Register. When any of the 8 BERTs issue an interrupt, a bit will be set.
RXPC	8A	Enable for the Receiver BERT
RBPBS	8B	Bit Suppression for the Receive BERT
RBPCS1-4	D4, D5, D6, D7	Channels to be enabled for the Framer to accept data from the BERT pattern generator
TXPC	18A	Enable for the Transmitter BERT
TBPBS	18B	Bit Suppression for the Transmit BERT
TBPCS1-4	1D4, 1D5, 1D6, 1D7	Channels to be enabled for the Framer to accept data from the Transmit BERT pattern generator
BAWC	1100	BERT Alternating Pattern Count Register
BRP1	1101	BERT Repetitive Pattern Set Register 1
BRP2	1102	BERT Repetitive Pattern Set Register 2
BRP3	1103	BERT Repetitive Pattern Set Register 3
BRP4	1104	BERT Repetitive Pattern Set Register 4
BC1	1105	Pattern Selection and Misc Control
BC2	1106	BERT Bit Pattern Length Control
BBC1	1107	BERT Bit Counter—Increments for BERT Bit clocks
BBC2	1108	BERT Bit Counter
BBC3	1109	BERT Bit Counter
BBC4	110A	BERT Bit Counter
BEC1	110B	BERT Error Counter
BEC2	110C	BERT Error Counter
BEC3	110D	BERT Error Counter
BLSR	110E	BERT Status Registers—Denotes Synchronization Loss and Other Status
BSIM	110F	BERT Interrupt Mask

Note: The addresses shown above are for Framer 1. Addresses for Framers 2 – 8 can be calculated using the following: Framer N = (Framer 1 address + (n-1) x 200hex); where n = 2 to 8 for Framers 2 to 8.

The BERT block can generate and detect the following patterns:

- The pseudo-random patterns 2E7-1, 2E9-1, 2E11-1, 2E15-1, and QRSS
- A repetitive pattern from 1 to 32 bits in length
- Alternating (16-bit) words that flip every 1 to 256 words
- Daly pattern

The BERT function must be enabled and configured in the [TXPC](#) and [RXPC](#) registers for each port. The BERT can then be assigned on a per-channel basis for both the transmitter and receiver, using the special per-channel function in the [TBPCS1-4](#) and [RBCS1-4](#) registers. Individual bit positions within the channels can be suppressed with the [TBPBS](#) and [RBPBS](#) registers. Using combinations of these functions, the BERT pattern can be transmitted and/or received in single or across multiple DS0s, contiguous or broken. Transmit and receive bandwidth assignments are independent of each other.

The BERT receiver has a 32-bit bit counter and a 24-bit error counter. The BERT receiver can generate interrupts on: a change in receive-synchronizer status, receive all zeros, receive all ones, error counter overflow, bit counter

overflow, and bit error detection. Interrupts from each of these events can be masked within the BERT function via the BERT Status Interrupt Mask Register ([BSIM](#)). If the software detects that the BERT has reported an event, then the software must read the BERT Latched Status Register ([BLSR](#)) to determine which event(s) has occurred.

9.12.1 BERT Repetitive Pattern Set

These registers must be properly loaded for the BERT to generate and synchronize to a repetitive pattern, a pseudo-random pattern, alternating word pattern, or a Daly pattern. For a repetitive pattern that is less than 32 bits, the pattern should be repeated so that all 32 bits are used to describe the pattern. For example, if the pattern was the repeating 5-bit pattern ...01101... (where the right-most bit is the one sent first and received first) then BRP1 should be loaded with ADh, BRP2 with B5h, BRP3 with D6h, and BRP4 should be loaded with 5Ah. For a pseudo-random pattern, all four registers should be loaded with all ones (i.e., FFh). For an alternating word pattern, one word should be placed into BRP1 and BRP2 and the other word should be placed into BRP3 and BRP4. For example, if the DDS stress pattern "7E" is to be described, the user would place 00h in BRP1, 00h in BRP2, 7Eh in BRP3, and 7Eh in BRP4, and the alternating word counter would be set to 50 (decimal) to allow 100 bytes of 00h followed by 100 bytes of 7Eh to be sent and received.

9.12.2 BERT Error Counter

Once BERT has achieved synchronization, this 24-bit counter will increment for each data bit received in error. Toggling the LC control bit in BC1 can clear this counter. This counter saturates when full and will set the BECO status bit in the [BLSR](#) register.

10. DEVICE REGISTERS

Thirteen address bits are used to control the settings of the registers. The address map is compatible with the Maxim/Dallas Semiconductor octal framer product, DS26401.

The registers control functions of the framers, LIUs, and BERTs within the DS26528. The map is divided into eight framers, followed by eight LIUs and eight BERTs. Global Registers (applicable to all eight transceivers and BERTs) are located within the address space of Framer 1.

The Bulk Write Mode is a special mode to write all eight transceivers with one write command (see the [GTCR1](#) register). [Figure 10-1](#) shows the register map.

The register details are provided in the following tables. The framer registers bits are provided for Framer 0 and address bits A11 to A8 determine the framer addressed.

10.1 Register Listings

The Framer Registers have an offset of 200 Hex, the LIU Registers have an offset of 20 Hex, and the BERT Registers have an offset of 10 Hex for each transceiver.

Table 10-1. Register Address Ranges (in Hex)

	GLOBAL REGISTERS	RECEIVE FRAMER	TRANSMIT FRAMER	LIU	BERT
	00F0 – 00FF	—	—	—	—
CH1	—	0000 – 00EF	0100 – 01EF	1000 – 101F	1100 – 110F
CH 2	—	0200 – 02EF	0300 – 03EF	1020 – 103F	1110 – 111F
CH 3	—	0400 – 04EF	0500 – 05EF	1040 – 105F	1120 – 112F
CH 4	—	0600 – 06EF	0700 – 07EF	1060 – 107F	1130 – 113F
CH 5	—	0800 – 08EF	0900 – 09EF	1080 – 109F	1140 – 114F
CH 6	—	0A00 – 0AEF	0B00 – 0BEF	10A0 – 10BF	1150 – 115F
CH 7	—	0C00 – 0CEF	0D00 – 0DEF	10C0 – 10DF	1160 – 116F
CH 8	—	0E00 – 0EEF	0F00 – 0FEF	10E0 – 10FF	1170 – 117F

Figure 10-1. Register Memory Map for the DS26528

Adrs = 0000 0000 0000	Framer 1 Rx Regs 240 Regs	000
Adrs = 0000 1111 0000	Global Registers	0EF 0F0
Adrs = 0001 0000 0000	Framer 1 Tx Regs 240 Regs	0FF 100
Adrs = 0001 1111 0000	Reserved	1EF 1F0
Adrs = 0010 0000 0000	Framer 2 Regs	1FF 200
Adrs = 0100 0000 0000	Framer 3 Regs	3FF 400
Adrs = 0101 1111 1111 Adrs = 0110 0000 0000	Framer 4 Regs	5FF 600
Adrs = 0111 1111 1111 Adrs = 1000 0000 0000	Framer 5 Regs	7FF 800
Adrs = 01001 1111 1111 Adrs = 01010 0000 0000	Framer 6 Regs	9FF A00
Adrs = 01011 1111 1111 Adrs = 01100 0000 0000	Framer 7 Regs	BFF C00
Adrs = 01101 1111 1111 Adrs = 01110 0000 0000	Framer 8 Regs	DFF E00
Adrs = 01111 1111 1111 Adrs = 10000 0000 0000	LIU Regs	FFF 1000
Adrs = 10000 1111 1111 Adrs = 10001 0000 0000	BERT	10FF 1100
Adrs = 10001 0111 1111	Reserved	117F
Adrs = 11111 1111 1111	Reserved	1FFF

10.1.1 Global Register List

Table 10-2. Global Register List

GLOBAL REGISTER LIST			
ADDR	ABBR	DESCRIPTION	R/W
00F0	GTCR1	Global Transceiver Control Register 1	R/W
00F1	GFCR	Global Framers Control Register	R/W
00F2	GTCR2	Global Transceiver Control Register 2	R/W
00F3	GTCCR	Global Transceiver Clock Control Register	R/W
00F4		Reserved	-
00F5	GLSRR	Global LIU Software Reset Register	R/W
00F6	GFSRR	Global Framers and BERT Software Reset Register	R/W
00F7		Reserved	-
00F8	IDR	Device ID Register	R
00F9	GFISR	Global Framers Interrupt Status Register	R
00FA	GBISR	Global BERT Interrupt Status Register	R
00FB	GLISR	Global LIU Interrupt Status Register	R
00FC	GFIMR	Global Framers Interrupt Mask Register	RW
00FD	GBIMR	Global BERT Interrupt Mask Register	RW
00FE	GLIMR	Global LIU Interrupt Mask Register	RW
001F		Reserved	-

Note 1: Reserved registers should only be written with all zeros.

Note 2: The global registers are located in the framer 1 address space. The corresponding address space for the other seven framers is "Reserved," and should be initialized with all zeros for proper operation.

10.1.2 Framers Register List

Table 10-3. Framers Register List

Note that only Framers 1 Address is presented here. The same set of registers definitions applies for transceiver 2 to 8 in accordance with the DS26528 map offsets. Transceiver offset is $(n-1) \times 200$ hex, where n designates the transceiver in question.

FRAMER REGISTER LIST			
ADDRESS	ABBR	DESCRIPTION	R/W
000 – 00F	-	Reserved	-
010	RHC	Rx HDLC Control	R/W
011	RHBSE	Rx HDLC Bit Suppress	R/W
012	RDS0SEL	Rx DS0 Monitor Select	R/W
013	RSIGC	Rx Signaling Control	R/W
014	T1RCR2	Rx Control 2 (T1 Mode Only)	R/W
015	T1RBOCC	Rx BOC Control (T1 Mode Only)	R/W
016 – 01F	-	Reserved	-
020	RIDR1	Rx Idle Definition 1	R/W
021	RIDR2	Rx Idle Definition 2	R/W
022	RIDR3	Rx Idle Definition 3	R/W
023	RIDR4	Rx Idle Definition 4	R/W
024	RIDR5	Rx Idle Definition 5	R/W
025	RIDR6	Rx Idle Definition 6	R/W
026	RIDR7	Rx Idle Definition 7	R/W
027	RIDR8	Rx Idle Definition 8	R/W
028	RIDR9	Rx Idle Definition 9	R/W
029	RIDR10	Rx Idle Definition 10	R/W
02A	RIDR11	Rx Idle Definition 11	R/W
02B	RIDR12	Rx Idle Definition 12	R/W
02C	RIDR13	Rx Idle Definition 13	R/W
02D	RIDR14	Rx Idle Definition 14	R/W

FRAMER REGISTER LIST			
ADDRESS	ABBR	DESCRIPTION	R/W
02E	RIDR15	Rx Idle Definition 15	R/W
02F	RIDR16	Rx Idle Definition 16	R/W
030	RIDR17	Rx Idle Definition 17	R/W
031	RIDR18	Rx Idle Definition 18	R/W
032	RIDR19	Rx Idle Definition 19	R/W
033	RIDR20	Rx Idle Definition 20	R/W
034	RIDR21	Rx Idle Definition 21	R/W
035	RIDR22	Rx Idle Definition 22	R/W
036	RIDR23	Rx Idle Definition 23	R/W
037	RIDR24	Rx Idle Definition 24	R/W
038	T1RSAO11 E1RIDR25	Rx Sig All Ones Insertion 1 (T1 Mode) Rx Idle Definition 25 (E1 Mode)	R/W
039	T1RSAO12 E1RIDR26	Rx Sig All Ones Insertion 2 (T1 Mode) Rx Idle Definition 26 (E1 Mode)	R/W
03A	T1RSAO13 E1RIDR27	Rx Sig All Ones Insertion 3 (T1 Mode) Rx Idle Definition 27 (E1 Mode)	R/W
03B	E1RIDR28	Rx Idle Definition 28 (E1 Mode)	-
03C	T1RDMWE1 E1RIDR29	Rx Digital Milliwatt Enable 1 (T1 Mode) Rx Idle Definition 29 (E1 Mode)	R/W
03D	T1RDMWE2 E1RIDR30	Rx Digital Milliwatt Enable 2 (T1 Mode) Rx Idle Definition 30 (E1 Mode)	R/W
03E	T1RDMWE3 E1RIDR31	Rx Digital Milliwatt Enable 3 (T1 Mode) Rx Idle Definition 31 (E1 Mode)	R/W
03F	E1RIDR32	Rx Idle Definition 32 (E1 Mode)	-
040	RS1	Rx Signaling 1	R
041	RS2	Rx Signaling 2	R
042	RS3	Rx Signaling 3	R
043	RS4	Rx Signaling 4	R
044	RS5	Rx Signaling 5	R
045	RS6	Rx Signaling 6	R
046	RS7	Rx Signaling 7	R
047	RS8	Rx Signaling 8	R
048	RS9	Rx Signaling 9	R
049	RS10	Rx Signaling 10	R
04A	RS11	Rx Signaling 11	R
04B	RS12	Rx Signaling 12	R
04C	RS13	Rx Signaling 13 (E1 Mode only)	-
04D	RS14	Rx Signaling 14 (E1 Mode only)	-
04E	RS15	Rx Signaling 15 (E1 Mode only)	-
04F	RS16	Rx Signaling 16 (E1 Mode only)	-
050	LCVCR1	Rx Line Code Violation Counter 1	R
051	LCVCR2	Rx Line Code Violation Counter 2	R
052	PCVCR1	Rx Path Code Violation Count 1	R
053	PCVCR2	Rx Path Code Violation Count 2	R
054	FOSCR1	Rx Frames Out of Sync Counter 1	R
055	FOSCR2	Rx Frames Out of Sync Counter 2	R
056	E1EBCR1	E1 Receive E-Bit Counter 1 (E1 Mode Only)	R
057	E1EBCR2	E1 Receive E-Bit Counter 2 (E1 Mode Only)	R
058-05F	-	Reserved	-
060	RDS0M	Rx DS0 Monitor	R
061	-	Reserved	-
062	T1RFDL E1RRTS7	Rx FDL (T1 Mode) E1 Receive Real-Time Status 7 (E1 Mode)	R
063	T1RBOC	Rx BOC (T1 Mode Only)	R

FRAMER REGISTER LIST			
ADDRESS	ABBR	DESCRIPTION	R/W
064	T1RSLC1 E1RAF	Rx SLC96 Data Link 1 (T1 Mode) E1 Receive Align Frame (E1 Mode)	R
065	T1RSLC2 E1RNAF	Rx SLC96 Data Link 2 (T1 Mode) E1 Receive Non-Align Frame (E1 Mode)	R
066	T1RSLC3 E1RsiAF	Rx SLC96 Data Link 3 (T1 Mode) E1 Receive Si Bits for Align Frame (E1 Mode)	R
067	E1RSiNAF	E1 Receive Si Bits for Non-Align Frame (E1 Mode Only)	R
068	E1RNAF	E1 Receive Remote Alarm Bits (E1 Mode Only)	R
069	E1RSa4	E1 Receive Sa4 Bits (E1 Mode Only)	R
06A	E1RSa5	E1 Receive Sa5 Bits (E1 Mode Only)	R
06B	E1RSa6	E1 Receive Sa6 Bits (E1 Mode Only)	R
06C	E1RSa7	E1 Receive Sa7 Bits (E1 Mode Only)	R
06D	E1RSa8	E1 Receive Sa8 Bits (E1 Mode Only)	R
06E-07F	-	Reserved	-
080	RMMR	Rx Master Mode	R/W
081	RCR1	Rx Control 1	R/W
082	T1RIBCC E1RCR2	Rx In-Band Code Control (T1 Mode) E1 Rx Control 2 (E1 Mode)	R/W
083	RCR3	Rx Control 3	R/W
084	RIOCR	Rx I/O Configuration	R/W
085	RESCR	Rx Elastic Store Control	R/W
086	ERCNT	Rx Error Count Configuration	R/W
087	RHFC	Rx HDLC FIFO Control	R/W
088	RIBOC	Rx Interleave Bus Op Control	R/W
089	T1RSCC	Rx Spare Code Control (T1 Mode Only)	R/W
08A	RXPC	Rx eXpansion Port Control Register	R/W
08B	RBPBS	Rx BERT Port Bit Suppress Register	R/W
08C-08F	-	Reserved	-
090	RLS1	Rx Latched Status 1	R/W
091	RLS2	Rx Latched Status 2	R/W
092	RLS3	Rx Latched Status 3	R/W
093	RLS4	Rx Latched Status 4	R/W
094	RLS5	Rx Latched Status 5	R/W
095	-	Reserved	-
096	RLS7	Rx Latched Status 7 (T1 Mode Only)	R/W
097	-	Reserved	-
098	RSS1	Rx Signaling CoS Status 1	R/W
099	RSS2	Rx Signaling CoS Status 2	R/W
09A	RSS3	Rx Signaling CoS Status 3	R/W
09B	RSS4	Rx Signaling CoS Status 4 (E1 Mode Only)	R/W
09C	T1RSCD1	Rx Spare Code Definition 1 (T1 Mode Only)	R/W
09D	T1RSCD2	Rx Spare Code Definition 2 (T1 Mode Only)	R/W
09E	-	Reserved	-
09F	RIIR	Rx Interrupt Information Reg	R/W
0A0	RIM1	Rx Interrupt Mask Reg 1	R/W
0A1	RIM2	E1 Rx Interrupt Mask Reg 2 (E1 Mode Only)	R/W
0A2	RIM3	Rx Interrupt Mask Reg 3	R/W
0A3	RIM4	Rx Interrupt Mask Reg 4	R/W
0A4	RIM5	Rx Interrupt Mask Reg 5	R/W
0A5	-	Reserved	-
0A6	RIM7	Rx Interrupt Mask Reg 7 (T1 Mode Only)	R/W
0A7	-	Reserved	-
0A8	RSCSE1	Rx Sig CoS Interrupt Enable 1	R/W
0A9	RSCSE2	Rx Sig CoS Interrupt Enable 2	R/W

FRAMER REGISTER LIST			
ADDRESS	ABBR	DESCRIPTION	R/W
0AA	RSCSE3	Rx Sig CoS Interrupt Enable 3	R/W
0AB	RSCSE4	Rx Sig CoS Interrupt Enable 4	-
0AC	T1RUPCD1	Rx Up Code Definition 1 (T1 Mode Only)	R/W
0AD	T1RUPCD2	Rx Up Code Definition 2 (T1 Mode Only)	R/W
0AE	T1RDNCD1	Rx Down Code Definition 1 (T1 Mode Only)	R/W
0AF	T1RDNCD2	Rx Down Code Definition 2 (T1 Mode Only)	R/W
0B0	RRTS1	Rx Real-Time Status 1	R
0B1	-	Reserved	-
0B2	RRTS3	Rx Real-Time Status 3	R
0B3	-	Reserved	-
0B4	RRTS5	Rx Real-Time Status 5 (HDLC)	R
0B5	RHPBA	Rx HDLC Packet Bytes Available	R
0B6	RHF	Rx HDLC FIFO	R
0B7-0BF	-	Reserved	-
0C0	RBCS1	Rx Blank Channel Select 1	R/W
0C1	RBCS2	Rx Blank Channel Select 2	R/W
0C2	RBCS3	Rx Blank Channel Select 3	R/W
0C3	RBCS4	Rx Blank Channel Select 4 (E1 Mode Only)	R/W
0C4	RCBR1	Rx Channel Blocking 1	R/W
0C5	RCBR2	Rx Channel Blocking 2	R/W
0C6	RCBR3	Rx Channel Blocking 3	R/W
0C7	RCBR4	Rx Channel Blocking 4 (E1 Mode Only)	R/W
0C8	RSI1	Rx Signaling Insertion 1	R/W
0C9	RSI2	Rx Signaling Insertion 2	R/W
0CA	RSI3	Rx Signaling Insertion 3	R/W
0CB	RSI4	Rx Signaling Insertion 4 (E1 Mode Only)	R/W
0CC	RGCCS1	Rx Gapped Clock Channel Select 1	R/W
0CD	RGCCS2	Rx Gapped Clock Channel Select 2	R/W
0CE	RGCCS3	Rx Gapped Clock Channel Select 3	R/W
0CF	RGCCS4	Rx Gapped Clock Channel Select 4 (E1 Mode Only)	R/W
0D0	RCICE1	Rx Channel Idle Code Enable 1	R/W
0D1	RCICE2	Rx Channel Idle Code Enable 2	R/W
0D2	RCICE3	Rx Channel Idle Code Enable 3	R/W
0D3	RCICE4	Rx Channel Idle Code Enable 4 (E1 Mode Only)	R/W
0D4	RBPCS1	Rx BERT Port Channel Select Register 1	R/W
0D5	RBPCS2	Rx BERT Port Channel Select Register 2	R/W
0D6	RBPCS3	Rx BERT Port Channel Select Register 3	R/W
0D7	RBPCS4	Rx BERT Port Channel Select Register 4 (E1 Mode Only)	R/W
0D8-0EF	-	Reserved	-
0F0-0FF	Global Registers (Section 10.3)	See the Global Register list in Table 10-2 . Note that this space is "Reserved" in Framers 2-8.	R/W
100-10F	-	Reserved	-
110	THC1	Tx HDLC Control 1	R/W
111	THBSE	Tx HDLC Bit Suppress	R/W
112	-	Reserved	-
113	THC2	Tx HDLC Control 2	R/W
114	E1TSACR	E1 Tx Sa Bit Control Register	R/W
115-117	-	Reserved	-
118	SSIE1	Tx Software Signaling Insertion Enable 1	R/W
119	SSIE2	Tx Software Signaling Insertion Enable 2	R/W
11A	SSIE3	Tx Software Signaling Insertion Enable 3	R/W
11B	SSIE4	Tx Software Signaling Insertion Enable 4 (E1 Mode Only)	R/W
11C-11F	Reserved	Reserved	-
120	TIDR1	Tx Idle Definition 1	R/W

FRAMER REGISTER LIST			
ADDRESS	ABBR	DESCRIPTION	R/W
121	TIDR2	Tx Idle Definition 2	R/W
122	TIDR3	Tx Idle Definition 3	R/W
123	TIDR4	Tx Idle Definition 4	R/W
124	TIDR5	Tx Idle Definition 5	R/W
125	TIDR6	Tx Idle Definition 6	R/W
126	TIDR7	Tx Idle Definition 7	R/W
127	TIDR8	Tx Idle Definition 8	R/W
128	TIDR9	Tx Idle Definition 9	R/W
129	TIDR10	Tx Idle Definition 10	R/W
12A	TIDR11	Tx Idle Definition 11	R/W
12B	TIDR12	Tx Idle Definition 12	R/W
12C	TIDR13	Tx Idle Definition 13	R/W
12D	TIDR14	Tx Idle Definition 14	R/W
12E	TIDR15	Tx Idle Definition 15	R/W
12F	TIDR16	Tx Idle Definition 16	R/W
130	TIDR17	Tx Idle Definition 17	R/W
131	TIDR18	Tx Idle Definition 18	R/W
132	TIDR19	Tx Idle Definition 19	R/W
133	TIDR20	Tx Idle Definition 20	R/W
134	TIDR21	Tx Idle Definition 21	R/W
135	TIDR22	Tx Idle Definition 22	R/W
136	TIDR23	Tx Idle Definition 23	R/W
137	TIDR24	Tx Idle Definition 24	R/W
138	TIDR25	Tx Idle Definition 25 (E1 Mode Only)	R/W
139	TIDR26	Tx Idle Definition 26 (E1 Mode Only)	R/W
13A	TIDR27	Tx Idle Definition 27 (E1 Mode Only)	R/W
13B	TIDR28	Tx Idle Definition 28 (E1 Mode Only)	R/W
13C	TIDR29	Tx Idle Definition 29 (E1 Mode Only)	R/W
13D	TIDR30	Tx Idle Definition 30 (E1 Mode Only)	R/W
13E	TIDR31	Tx Idle Definition 31 (E1 Mode Only)	R/W
13F	TIDR32	Tx Idle Definition 32 (E1 Mode Only)	R/W
140	TS1	Tx Signaling 1	R/W
141	TS2	Tx Signaling 2	R/W
142	TS3	Tx Signaling 3	R/W
143	TS4	Tx Signaling 4	R/W
144	TS5	Tx Signaling 5	R/W
145	TS6	Tx Signaling 6	R/W
146	TS7	Tx Signaling 7	R/W
147	TS8	Tx Signaling 8	R/W
148	TS9	Tx Signaling 9	R/W
149	TS10	Tx Signaling 10	R/W
14A	TS11	Tx Signaling 11	R/W
14B	TS12	Tx Signaling 12	R/W
14C	TS13	Tx Signaling 13	R/W
14D	TS14	Tx Signaling 14	R/W
14E	TS15	Tx Signaling 15	R/W
14F	TS16	Tx Signaling 16	R/W
150	TCICE1	Tx Channel Idle Code Enable 1	R/W
151	TCICE2	Tx Channel Idle Code Enable 2	R/W
152	TCICE3	Tx Channel Idle Code Enable 3	R/W
153	TCICE4	Tx Channel Idle Code Enable 4 (E1 Mode Only)	R/W
154-161	-	Reserved	-
162	T1TFDL	Tx FDL (T1 Mode Only)	R/W
163	T1TBOC	Tx BOC (T1 Mode Only)	R/W

FRAMER REGISTER LIST			
ADDRESS	ABBR	DESCRIPTION	R/W
164	T1TSLC1 E1TAF	Tx SLC96 Data Link 1 (T1 Mode) E1 Tx Align Frame (E1 Mode)	R/W
165	T1TSLC2 E1TNAF	Tx SLC96 Data Link 2 (T1 Mode) E1 Tx Non-Align Frame (E1 Mode)	R/W
166	T1TSLC3 E1TSiAF	Tx SLC96 Data Link 3 (T1 Mode) E1 Tx Si bits for Align Frame (E1 Mode)	R/W
167	E1TSiNAF	E1 Tx Si bits for Non-Align Frame (E1 Mode Only)	R/W
168	E1TRA	E1 Tx Remote Alarm (E1 Mode Only)	R/W
169	E1TSa4	E1 Tx Sa4 Bits (E1 Mode Only)	R/W
16A	E1TSa5	E1 Tx Sa5 Bits (E1 Mode Only)	R/W
16B	E1TSa6	E1 Tx Sa6 Bits (E1 Mode Only)	R/W
16C	E1TSa7	E1 Tx Sa7 Bits (E1 Mode Only)	R/W
16D	E1TSa8	E1 Tx Sa8 Bits (E1 Mode Only)	R/W
16E-17F	-	Reserved	-
180	TMMR	Tx Master Mode	R/W
181	TCR1	Tx Control 1	R/W
182	TCR2	Tx Control 2	R/W
183	TCR3	Tx Control 3	R/W
184	TIOCR	Tx I/O Configuration	R/W
185	TESCR	Tx Elastic Store Control	R/W
186	TCR4	Tx Control 4 (T1 Mode Only)	R/W
187	THFC	Tx HDLC FIFO Control	R/W
188	TIBOC	Tx Interleave Bus Op Control	R/W
189	TDS0SEL	Tx DS0 Monitor Select	R/W
18A	TXPC	Tx eXpansion Port Control	R/W
18B	TBPBS	Tx BERT Port Bit Suppress	R/W
18C-18D	-	Reserved	-
18E	TSYNCC	Tx Synchronizer Control	R/W
18F	Reserved	Reserved	-
190	TLS1	Tx Latched Status 1	R/W
191	TLS2	Tx Latched Status 2 (HDLC)	R/W
192	TLS3	Tx Latched Status 3 (SYNC)	R/W
193-19E	-	Reserved	-
19F	TIIR	Tx Interrupt Information Register	R/W
1A0	TIM1	Tx Interrupt Mask Register 1	R/W
1A1	TIM2	Tx Interrupt Mask Register 2 (HDLC)	R/W
1A2	TIM3	Tx Interrupt Mask Register 3 (SYNC)	R/W
1A3-1AB	-	Reserved	-
1AC	T1TCD1	Tx Code Definition 1 (T1 Mode Only)	R/W
1AD	T1TCD2	Tx Code Definition 2 (T1 Mode Only)	R/W
1AE-1B0	-	Reserved	-
1B1	TRTS2	Tx Real-Time Status Register 2 (HDLC)	R
1B2	-	Reserved	-
1B3	TFBA	Tx HDLC FIFO Buffer Available	R
1B4	THF	Tx HDLC FIFO	W
1B5-1BA	-	Reserved	-
1BB	TDS0M	Tx DS0 Monitor	R
1BC-1BF	-	Reserved	-
1C0	TBSC1	Tx Blank Channel Select 1	R/W
1C1	TBSC2	Tx Blank Channel Select 2	R/W
1C2	TBSC3	Tx Blank Channel Select 3	R/W
1C3	TBSC4	Tx Blank Channel Select 4 (E1 Mode Only)	R/W
1C4	TCBR1	Tx Channel Blocking 1	R/W
1C5	TCBR2	Tx Channel Blocking 2	R/W

FRAMER REGISTER LIST			
ADDRESS	ABBR	DESCRIPTION	R/W
1C6	TCBR3	Tx Channel Blocking 3	R/W
1C7	TCBR4	Tx Channel Blocking 4 (E1 Mode Only)	R/W
1C8	THSCS1	Tx Hardware Signaling Channel Select 1	R/W
1C9	THSCS2	Tx Hardware Signaling Channel Select 2	R/W
1CA	THSCS3	Tx Hardware Signaling Channel Select 3	R/W
1CB	THSCS4	Tx Hardware Signaling Channel Select 4 (E1 Mode Only)	R/W
1CC	TGCCS1	Tx Gapped Clock Channel Select 1	R/W
1CD	TGCCS2	Tx Gapped Clock Channel Select 2	R/W
1CE	TGCCS3	Tx Gapped Clock Channel Select 3	R/W
1CF	TGCCS4	Tx Gapped Clock Channel Select 4 (E1 Mode Only)	R/W
1D0	PCL1	Per-Channel Loopback Enable 1	R/W
1D1	PCL2	Per-Channel Loopback Enable 2	R/W
1D2	PCL3	Per-Channel Loopback Enable 3	R/W
1D3	PCL4	Per-Channel Loopback Enable 4 (E1 Mode Only)	R/W
1D4	TBPCS1	Tx BERT Channel Select 1	R/W
1D5	TBPCS2	Tx BERT Channel Select 2	R/W
1D6	TBPCS3	Tx BERT Channel Select 3	R/W
1D7	TBPCS4	Tx BERT Channel Select 4 (E1 Mode Only)	R/W
1D8-1FF	-	Reserved	-

10.1.3 LIU and BERT Register List

Table 10-4. LIU Register List

LIU REGISTER LIST		
ADDRESS	DESCRIPTION	ABBR
1000	LIU Transmit Receive Control Register	LTRCR
1001	LIU Transmit Impedance Selection Register	LTISR
1002	LIU Maintenance and Jitter Attenuator Control Register	LMJCR
1003	LIU Real Status Register	LRSR
1004	LIU Status Interrupt Mask Register	LSIMR
1005	LIU Latched Status Register	LLSR
1006	LIU Receive Signal Level	LRSL
1007	LIU Receive Impedance and Sensitivity Monitor Register	LRISMR
1008-101F	Reserved	

Table 10-5. BERT Register List

BERT REGISTER LIST		
ADDRESS	DESCRIPTION	ABBR
1100	BERT Alternating Word Count Rate	BAWC
1101	BERT Repetitive Pattern Set Register 1	BRP1
1102	BERT Repetitive Pattern Set Register 2	BRP2
1103	BERT Repetitive Pattern Set Register 3	BRP3
1104	BERT Repetitive Pattern Set Register 4	BRP4
1105	BERT Control Register 1	BC1
1106	BERT Control Register 2	BC2
1107	BERT Bit Count Register 1	BBC1
1108	BERT Bit Count Register 2	BBC2
1109	BERT Bit Count Register 3	BBC3
110A	BERT Bit Count Register 4	BBC4
110B	BERT Error Count Register 1	BEC1
110C	BERT Error Count Register 2	BEC2
110D	BERT Error Count Register 3	BEC3
110E	BERT Latched Status Register	BLSR
110F	BERT Status Interrupt Mask Register	BSIMR

10.2 Register Bit Maps

10.2.1 Global Register Bit Map

Table 10-6. Global Register Bit Map

ADDR	NAME	BIT 7	BIT 6	BIT 5	BIT 4	BIT 3	BIT 2	BIT 1	BIT 0
00F0	GTCCR1	--	--	RLOFLTS	GIBO	--	BWE	GCLE	GIPI
00F1	GFCCR	IBOMS1	IBOMS0	BPCLK1	BPCLK0	RFLOSSFS	RFMSS	TCBCS	RCBCS
00F2	GTCCR2	--	--	--	--	--	LOSS	TSSYNIOSEL	--
00F3	GTCCR	BPRFSEL3	BPRFSEL2	BPRFSEL1	BPRFSEL0	BFREQSEL	FREQSEL	MPS1	MPS0
00F4		-	-	-	-	-	-	-	-
00F5	GLSRR	LSRST8	LSRST7	LSRST6	LSRST5	LSRST4	LSRST3	LSRST2	LSRST1
00F6	GFSRR	FSRST8	FSRST7	FSRST6	FSRST5	FSRST4	FSRST3	FSRST2	FSRST1
00F7		-	-	-	-	-	-	-	-
00F8	IDR	ID7	ID6	ID5	ID4	ID3	ID2	ID1	ID0
00F9	GFISR	FIS8	FIS7	FIS6	FIS5	FIS4	FIS3	FIS2	FIS1
00FA	GBISR	BIS8	BIS7	BIS6	BIS5	BIS4	BIS3	BIS2	BIS1
00FB	GLISR	LIS8	LIS7	LIS6	LIS5	LIS4	LIS3	LIS2	LIS1
00FC	GFIMR	FIM8	FIM7	FIM6	FIM5	FIM4	FIM3	FIM2	FIM1
00FD	GBIMR	BIM8	BIM7	BIM6	BIM5	BIM4	BIM3	BIM2	BIM1
00FE	GLIMR	LIM8	LIM7	LIM6	LIM5	LIM4	LIM3	LIM2	LIM1

10.2.2 Framer Register Bit Map

Table 10-7 contains the framer registers of the DS26528. Some registers have dual functionality based on the selection of T1/J1 or E1 operating mode in the RMMR and TMMR registers. These dual-function registers are shown below using two lines of text. The first line of text is the bit functionality for T1/J1 mode. The second line is the bit functionality in E1 mode, in *italics*. Bits that are not used for an operating mode are noted with a single dash “-”. When there is only one set of bit definitions listed for a register, the bit functionality does not change with respect to the selection of T1/J1 or E1 mode. All registers not listed are reserved and should be initialized with a value of 00h for proper operation. The addresses shown are for Framer 1. Addresses for Framers 2 – 8 can be calculated using the following formula: Address for Framer N = (Framer 1 address + (N-1) x 200hex).

Table 10-7. Framer Register Bit Map

ADDR	NAME	BIT 7	BIT 6	BIT 5	BIT 4	BIT 3	BIT 2	BIT 1	BIT 0
0010	RHC	RCRCD	RHR	RHMS	RHCS4	RHCS3	RHCS2	RHCS1	RHCS0
0011	RHBSE	BSE8	BSE7	BSE6	BSE5	BSE4	BSE3	BSE2	BSE1
0012	RDS0SEL	-	-	-	RCM4	RCM3	RCM2	RCM1	RCM0
0013	RSIGC	-	-	-	RFA1 <i>CASMS</i>	-	RSFF <i>RSFF</i>	RSFE <i>RSFE</i>	RSIE <i>RSIE</i>
0014	T1RCR2	-	-	-	RSLC96	OOF2	OOF1	RAIIE	RD4RM
0015	T1RBOCC	RBR	-	RBD1	RBD0	-	RBF1	RBF0	-
0020	RIDR1	C7	C6	C5	C4	C3	C2	C1	C0
0021	RIDR2	C7	C6	C5	C4	C3	C2	C1	C0
0022	RIDR3	C7	C6	C5	C4	C3	C2	C1	C0
0023	RIDR4	C7	C6	C5	C4	C3	C2	C1	C0
0024	RIDR5	C7	C6	C5	C4	C3	C2	C1	C0
0025	RIDR6	C7	C6	C5	C4	C3	C2	C1	C0
0026	RIDR7	C7	C6	C5	C4	C3	C2	C1	C0
0027	RIDR8	C7	C6	C5	C4	C3	C2	C1	C0
0028	RIDR9	C7	C6	C5	C4	C3	C2	C1	C0
0029	RIDR10	C7	C6	C5	C4	C3	C2	C1	C0
002A	RIDR11	C7	C6	C5	C4	C3	C2	C1	C0
002B	RIDR12	C7	C6	C5	C4	C3	C2	C1	C0
002C	RIDR13	C7	C6	C5	C4	C3	C2	C1	C0
002D	RIDR14	C7	C6	C5	C4	C3	C2	C1	C0
002E	RIDR15	C7	C6	C5	C4	C3	C2	C1	C0
002F	RIDR16	C7	C6	C5	C4	C3	C2	C1	C0
0030	RIDR17	C7	C6	C5	C4	C3	C2	C1	C0
0031	RIDR18	C7	C6	C5	C4	C3	C2	C1	C0
0032	RIDR19	C7	C6	C5	C4	C3	C2	C1	C0
0033	RIDR20	C7	C6	C5	C4	C3	C2	C1	C0
0034	RIDR21	C7	C6	C5	C4	C3	C2	C1	C0
0035	RIDR22	C7	C6	C5	C4	C3	C2	C1	C0
0036	RIDR23	C7	C6	C5	C4	C3	C2	C1	C0
0037	RIDR24	C7	C6	C5	C4	C3	C2	C1	C0
0038	T1RSAOI1 <i>RIDR25</i>	CH8 <i>C7</i>	CH7 <i>C6</i>	CH6 <i>C5</i>	CH5 <i>C4</i>	CH4 <i>C3</i>	CH3 <i>C2</i>	CH2 <i>C1</i>	CH1 <i>C0</i>
0039	T1RSAOI2 <i>RIDR26</i>	CH16 <i>C7</i>	CH15 <i>C6</i>	CH14 <i>C5</i>	CH13 <i>C4</i>	CH12 <i>C3</i>	CH11 <i>C2</i>	CH10 <i>C1</i>	CH9 <i>C0</i>
003A	T1RSAOI3 <i>RIDR27</i>	CH24 <i>C7</i>	CH23 <i>C6</i>	CH22 <i>C5</i>	CH21 <i>C4</i>	CH20 <i>C3</i>	CH19 <i>C2</i>	CH18 <i>C1</i>	CH17 <i>C0</i>
003B	RIDR28	- <i>C7</i>	- <i>C6</i>	- <i>C5</i>	- <i>C4</i>	- <i>C3</i>	- <i>C2</i>	- <i>C1</i>	- <i>C0</i>
003C	T1RDMWE1 <i>RIDR29</i>	CH8 <i>C7</i>	CH7 <i>C6</i>	CH6 <i>C5</i>	CH5 <i>C4</i>	CH4 <i>C3</i>	CH3 <i>C2</i>	CH2 <i>C1</i>	CH1 <i>C0</i>
003D	T1RDMWE2 <i>RIDR30</i>	CH16 <i>C7</i>	CH15 <i>C6</i>	CH14 <i>C5</i>	CH13 <i>C4</i>	CH12 <i>C3</i>	CH11 <i>C2</i>	CH10 <i>C1</i>	CH9 <i>C0</i>
003E	T1RDMWE3 <i>RIDR31</i>	CH24 <i>C7</i>	CH23 <i>C6</i>	CH22 <i>C5</i>	CH21 <i>C4</i>	CH20 <i>C3</i>	CH19 <i>C2</i>	CH18 <i>C1</i>	CH17 <i>C0</i>
003F	RIDR32	-	-	-	-	-	-	-	-

ADDR	NAME	BIT 7	BIT 6	BIT 5	BIT 4	BIT 3	BIT 2	BIT 1	BIT 0
		C7	C6	C5	C4	C3	C2	C1	C0
0040	RS1	CH1-A 0	CH1-B 0	CH1-C 0	CH1-D 0	CH13-A X	CH13-B Y	CH13-C X	CH13-D X
0041	RS2	CH2-A CH1-A	CH2-B CH1-B	CH2-C CH1-C	CH2-D CH1-D	CH14-A CH16-A	CH14-B CH16-B	CH14-C CH16-C	CH14-D CH16-D
0042	RS3	CH3-A CH2-A	CH3-B CH2-B	CH3-C CH2-C	CH3-D CH2-D	CH15-A CH17-A	CH15-B CH17-B	CH15-C CH17-C	CH15-D CH17-D
0043	RS4	CH4-A CH3-A	CH4-B CH3-B	CH4-C CH3-C	CH4-D CH3-D	CH16-A CH18-A	CH16-B CH18-B	CH16-C CH18-C	CH16-D CH18-D
0044	RS5	CH5-A CH4-A	CH5-B CH4-B	CH5-C CH4-C	CH5-D CH4-D	CH17-A CH19-A	CH17-B CH19-B	CH17-C CH19-C	CH17-D CH19-D
0045	RS6	CH6-A CH5-A	CH6-B CH5-B	CH6-C CH5-C	CH6-D CH5-D	CH18-A CH20-A	CH18-B CH20-B	CH18-C CH20-C	CH18-D CH20-D
0046	RS7	CH7-A CH6-A	CH7-B CH6-B	CH7-C CH6-C	CH7-D CH6-D	CH19-A CH21-A	CH19-B CH21-B	CH19-C CH21-C	CH19-D CH21-D
0047	RS8	CH8-A CH7-A	CH8-B CH7-B	CH8-C CH7-C	CH8-D CH7-D	CH20-A CH22-A	CH20-B CH22-B	CH20-C CH22-C	CH20-D CH22-D
0048	RS9	CH9-A CH8-A	CH9-B CH8-B	CH9-C CH8-C	CH9-D CH8-D	CH21-A CH23-A	CH21-B CH23-B	CH21-C CH23-C	CH21-D CH23-D
0049	RS10	CH10-A CH9-A	CH10-B CH9-B	CH10-C CH9-C	CH10-D CH9-D	CH22-A CH24-A	CH22-B CH24-B	CH22-C CH24-C	CH22-D CH24-D
004A	RS11	CH11-A CH10-A	CH11-B CH10-B	CH11-C CH10-C	CH11-D CH10-D	CH23-A CH25-A	CH23-B CH25-B	CH23-C CH25-C	CH23-D CH25-D
004B	RS12	CH12-A CH11-A	CH12-B CH11-B	CH12-C CH11-C	CH12-D CH11-D	CH24-A CH26-A	CH24-B CH26-B	CH24-C CH26-C	CH24-D CH26-D
004C	RS13	- CH12-A	- CH12-B	- CH12-C	- CH12-D	- CH27-A	- CH27-B	- CH27-C	- CH27-D
004D	RS14	- CH13-A	- CH13-B	- CH13-C	- CH13-D	- CH28-A	- CH28-B	- CH28-C	- CH28-D
004E	RS15	- CH14-A	- CH14-B	- CH14-C	- CH14-D	- CH29-A	- CH29-B	- CH29-C	- CH29-D
004F	RS16	- CH15-A	- CH15-B	- CH15-C	- CH15-D	- CH30-A	- CH30-B	- CH30-C	- CH30-D
0050	LCVCR1	LCVC15	LCVC14	LCVC13	LCVC12	LCVC11	LCVC10	LCVC9	LCCV8
0051	LCVCR2	LCVC7	LCVC6	LCVC5	LCVC4	LCVC3	LCVC2	LCVC1	LCVC0
0052	PCVCR1	PCVC15	PCVC14	PCVC13	PCVC12	PCVC11	PCVC10	PCVC9	PCVC8
0053	PCVCR2	PCVC7	PCVC6	PCVC5	PCVC4	PCVC3	PCVC2	PCVC1	PCVC0
0054	FOSCR1	FOS15	FOS14	FOS13	FOS12	FOS11	FOS10	FOS9	FOS8
0055	FOSCR2	FOS7	FOS6	FOS5	FOS4	FOS3	FOS2	FOS1	FOS0
0056	E1EBCR1	EB15	EB14	EB13	EB12	EB11	EB10	EB9	EB8
0057	E1EBCR2	EB7	EB6	EB5	EB4	EB3	EB2	EB1	EB0
0060	RDS0M	B1	B2	B3	B4	B5	B6	B7	B8
0061	-	-	-	-	-	-	-	-	-
0062	T1RFDL E1RRTS7	RFDL7 CSC5	RFDL6 CSC4	RFDL5 CSC3	RFDL4 CSC2	RFDL3 CSC0	RFDL2 CRC4SA	RFDL1 CASSA	RFDL0 FASSA
0063	T1RBOC	-	-	RBOC5	RBOC4	RBOC3	RBOC2	RBOC1	RBOC0
0064	T1RSLC1 E1RAF	C8 Si	C7 0	C6 0	C5 1	C4 1	C3 0	C2 1	C1 1
0065	T1RSLC2 E1RNAF	M2 Si	M1 1	S=0 A	S=1 Sa4	S=0 Sa5	C11 Sa6	C10 Sa7	C9 Sa8
0066	T1RSLC3 E1RSiAF	S=1 SiF14	S4 SiF12	S3 SiF10	S2 SiF8	S1 SiF6	A2 SiF4	A1 SiF2	M3 SiF0
0067	E1RSiNAF	- SiF15	- SiF13	- SiF11	- SiF9	- SiF7	- SiF5	- SiF3	- SiF1
0068	E1RNAF	- RRAF15	- RRAF13	- RRAF11	- RRAF9	- RRAF7	- RRAF5	- RRAF3	- RRAF1
0069	E1RSa4	- RSa4F15	- RSa4F13	- RSa4F11	- RSa4F9	- RSa4F7	- RSa4F5	- RSa4F3	- RSa4F1
006A	E1RSa5	- RSa5F15	- RSa5F13	- RSa5F11	- RSa5F9	- RSa5F7	- RSa5F5	- RSa5F3	- RSa5F1
006B	E1RSa6	- RSa6F15	- RSa6F13	- RSa6F11	- RSa6F9	- RSa6F7	- RSa6F5	- RSa6F3	- RSa6F1

ADDR	NAME	BIT 7	BIT 6	BIT 5	BIT 4	BIT 3	BIT 2	BIT 1	BIT 0
006C	E1RSa7	-	-	-	-	-	-	-	-
		<i>RSa7F15</i>	<i>RSa7F13</i>	<i>RSa7F11</i>	<i>RSa7F9</i>	<i>RSa7F7</i>	<i>RSa7F5</i>	<i>RSa7F3</i>	<i>RSa7F1</i>
006D	E1RSa8	-	-	-	-	-	-	-	-
		<i>RSa8F15</i>	<i>RSa8F13</i>	<i>RSa8F11</i>	<i>RSa8F9</i>	<i>RSa8F7</i>	<i>RSa8F5</i>	<i>RSa8F3</i>	<i>RSa8F1</i>
0080	RMMR	FRM_EN	INIT_DONE	-	-	-	-	SFTRST	T1/E1
0081	RCR1	SYNCT	RB8ZS <i>RHDB3</i>	RFM <i>RSIGM</i>	ARC <i>RG802</i>	SYNCC <i>RCRC4</i>	RJC <i>FRC</i>	SYNCE <i>SYNCE</i>	RESYNC <i>RESYNC</i>
0082	T1RIBCC E1RCR2	-	-	RUP2 <i>RSa6S</i>	RUP1 <i>RSa5S</i>	RUP0 <i>RSa4S</i>	RDN2	RDN1	RDN0 <i>RLOSA</i>
		<i>RSa8S</i>	<i>RSa7S</i>						
0083	RCR3	IDF	-	RSERC	-	-	-	PLB	FLB
0084	RIOCR	RCLKINV <i>RCLKINV</i>	RSYNCCINV <i>RSYNCCINV</i>	H100EN <i>H100EN</i>	RSCLKM <i>RSCLKM</i>	RSMS	RSIO <i>RSIO</i>	RSMS2 <i>RSMS2</i>	RSMS1 <i>RSMS1</i>
0085	RESCR	RDATAFMT	RGCLKEN	-	RSZS	RESALGN	RESR	RESMDM	RESE
0086	ERCNT	1SECS <i>1SECS</i>	MCUS <i>MCUS</i>	MECU <i>MECU</i>	ECUS <i>ECUS</i>	EAMS <i>EAMS</i>	FSBE	MOSCRF	LCVCRF <i>LCVCRF</i>
0087	RHFC	-	-	-	-	-	-	RFHWM1	RFHWM0
0088	RIBOC	-	IBS1	IBS0	IBOSEL	IBOEN	DA2	DA1	DA0
0089	T1RSCC	-	-	-	-	-	RSC2	RSC1	RSC0
		-	-	-	-	-	-	-	-
008A	RXPC	RHPBMS	RHPBEN	RHPAMS	RHPAEN	-	RBPDIR <i>RBPDIR</i>	RBPBUS	RBPEN <i>RBPEN</i>
		-	-	-	-	-	-	-	-
008B	RBPBS	BPBSE8	BPBSE7	BPBSE6	BPBSE5	BPBSE4	BPBSE3	BPBSE2	BPBSE1
0090	RLS1	RRAIC	RAISC	RLOSC	RLOFC	RRAID	RAISD	RLOSD	RLOFD
0091	RLS2	RPDV	-	COFA <i>CASRC</i>	8ZD <i>FASRC</i>	16ZD <i>RSA1</i>	SEFE <i>RSa0</i>	B8ZS <i>RCMF</i>	FBE <i>RAF</i>
0092	RLS3	LORCC <i>LORCC</i>	LSPC	LDNC <i>V52LNKC</i>	LUPC <i>RDMAC</i>	LORCD <i>LORCD</i>	LSPD	LDND <i>V52LNKD</i>	LUPD <i>RDMA</i>
0093	RLS4	RESF	RESEM	RSLIP	-	RSCOS	1SEC	TIMER	RMF
0094	RLS5	-	-	ROVR	RHOBT	RPE	RPS	RHWMS	RNES
0096	RLS7	-	-	RRAI-CI	RAIS-CI	RSLC96	RFDLF	BC	BD
		-	-	-	-	-	-	-	-
0097	-	-	-	-	-	-	-	-	-
0098	RSS1	CH8	CH7	CH6	CH5	CH4	CH3	CH2	CH1
0099	RSS2	CH16	CH15	CH14	CH13	CH12	CH11	CH10	CH9
009A	RSS3	CH24	CH23	CH22	CH21	CH20	CH19	CH18	CH17
009B	RSS4	-	-	-	-	-	-	-	-
		<i>CH32</i>	<i>CH31</i>	<i>CH30</i>	<i>CH29</i>	<i>CH28</i>	<i>CH27</i>	<i>CH26</i>	<i>CH25</i>
009C	T1RSCD1	C7	C6	C5	C4	C3	C2	C1	C0
		-	-	-	-	-	-	-	-
009D	T1RSCD2	C7	C6	C5	C4	C3	C2	C1	C0
		-	-	-	-	-	-	-	-
009F	RIIR	-	RLS7	RLS6**	RLS5 <i>RLS5</i>	RLS4 <i>RLS4</i>	RLS3 <i>RLS3</i>	RLS2* <i>RLS2</i>	RLS1 <i>RLS1</i>
		-	-	-	-	-	-	-	-
00A0	RIM1	RRAIC	RAISC	RLOSC	RLOFC	RRAID	RAISD	RLOSD	RLOFD
00A1	RIM2	-	-	-	-	<i>RSA1</i>	<i>RSa0</i>	<i>RCMF</i>	<i>RAF</i>
		-	-	-	-	-	-	-	-
00A2	RIM3	LORCC <i>LORCC</i>	LSPC	LDNC <i>V52LNKC</i>	LUPC <i>RDMAC</i>	LORCD <i>LORCD</i>	LSPD	LDND <i>V52LNKD</i>	LUPD <i>RDMA</i>
00A3	RIM4	RESF	RESEM	RSLIP	-	RSCOS	1SEC	TIMER	RMF
00A4	RIM5	-	-	ROVR	RHOBT	RPE	RPS	RHWMS	RNES
00A6	RIM7	-	-	RRAI-CI	RAIS-CI	RSLC96	RFDLF	BC	BD
00A8	RSCSE1	CH8	CH7	CH6	CH5	CH4	CH3	CH2	CH1
00A9	RSCSE2	CH16	CH15	CH14	CH13	CH12	CH11	CH10	CH9
00AA	RSCSE3	CH24	CH23	CH22	CH21	CH20	CH19	CH18	CH17
00AB	RSCSE4	-	-	-	-	-	-	-	-
		<i>CH32</i>	<i>CH31</i>	<i>CH30</i>	<i>CH29</i>	<i>CH28</i>	<i>CH27</i>	<i>CH26</i>	<i>CH25</i>
00AC	T1RUPCD1	C7	C6	C5	C4	C3	C2	C1	C0
		-	-	-	-	-	-	-	-
00AD	T1RUPCD2	C7	C6	C5	C4	C3	C2	C1	C0
		-	-	-	-	-	-	-	-
00AE	T1RDNCD1	C7	C6	C5	C4	C3	C2	C1	C0

ADDR	NAME	BIT 7	BIT 6	BIT 5	BIT 4	BIT 3	BIT 2	BIT 1	BIT 0
		-	-	-	-	-	-	-	-
00AF	T1RDNCD2	C7	C6	C5	C4	C3	C2	C1	C0
00B0	RRTS1	-	-	-	-	RRAI	RAIS	RLOS	RLOF
00B2	RRTS3	-	-	-	-	LORC LORC	LSP	LDN V52LNK	LUP RDMA
00B4	RRTS5	-	PS2	PS1	PS0	-	-	RHWM	RNE
00B5	RHPBA	MS	RPBA6	RPBA5	RPBA4	RPBA3	RPBA2	RPBA1	RPBA0
00B6	RHF	RHD7	RHD6	RHD5	RHD4	RHD3	RHD2	RHD1	RHD0
0C00	RBCS1	CH8	CH7	CH6	CH5	CH4	CH3	CH2	CH1
00C1	RBCS2	CH16	CH15	CH14	CH13	CH12	CH11	CH10	CH9
00C2	RBCS3	CH24	CH23	CH22	CH21	CH20	CH19	CH18	CH17
00C3	RBCS4	-	-	-	-	-	-	-	-
		<i>CH32</i>	<i>CH31</i>	<i>CH30</i>	<i>CH29</i>	<i>CH28</i>	<i>CH27</i>	<i>CH26</i>	<i>CH25</i>
00C4	RCBR1	CH8	CH7	CH6	CH5	CH4	CH3	CH2	CH1
00C5	RCBR2	CH16	CH15	CH14	CH13	CH12	CH11	CH10	CH9
00C6	RCBR3	CH24	CH23	CH22	CH21	CH20	CH19	CH18	CH17
00C7	RCBR4	-	-	-	-	-	-	-	-
		<i>CH32</i>	<i>CH31</i>	<i>CH30</i>	<i>CH29</i>	<i>CH28</i>	<i>CH27</i>	<i>CH26</i>	<i>CH25:Fbit</i>
00C8	RSI1	CH8	CH7	CH6	CH5	CH4	CH3	CH2	CH1
00C9	RSI2	CH16	CH15	CH14	CH13	CH12	CH11	CH10	CH9
00CA	RSI3	CH24	CH23	CH22	CH21	CH20	CH19	CH18	CH17
00CB	RSI4	-	-	-	-	-	-	-	-
		<i>CH32</i>	<i>CH31</i>	<i>CH30</i>	<i>CH29</i>	<i>CH28</i>	<i>CH27</i>	<i>CH26</i>	<i>CH25</i>
00CC	RGCCS1	CH8	CH7	CH6	CH5	CH4	CH3	CH2	CH1
00CD	RGCCS2	CH16	CH15	CH14	CH13	CH12	CH11	CH10	CH9
00CE	RGCCS3	CH24	CH23	CH22	CH21	CH20	CH19	CH18	CH17
00CF	RGCCS4	-	-	-	-	-	-	-	-
		<i>CH32</i>	<i>CH31</i>	<i>CH30</i>	<i>CH29</i>	<i>CH28</i>	<i>CH27</i>	<i>CH26</i>	<i>CH25:Fbit</i>
00D0	RCICE1	CH8	CH7	CH6	CH5	CH4	CH3	CH2	CH1
00D1	RCICE2	CH16	CH15	CH14	CH13	CH12	CH11	CH10	CH9
00D2	RCICE3	CH24	CH23	CH22	CH21	CH20	CH19	CH18	CH17
00D3	RCICE4	-	-	-	-	-	-	-	-
		<i>CH32</i>	<i>CH31</i>	<i>CH30</i>	<i>CH29</i>	<i>CH28</i>	<i>CH27</i>	<i>CH26</i>	<i>CH25</i>
00D4	RBPCS1	CH8	CH7	CH6	CH5	CH4	CH3	CH2	CH1
00D5	RBPCS2	CH16	CH15	CH14	CH13	CH12	CH11	CH10	CH9
00D6	RBPCS3	CH24	CH23	CH22	CH21	CH20	CH19	CH18	CH17
00D7	RBPCS4	-	-	-	-	-	-	-	-
		<i>CH32</i>	<i>CH31</i>	<i>CH30</i>	<i>CH29</i>	<i>CH28</i>	<i>CH27</i>	<i>CH26</i>	<i>CH25</i>
0110	THC1	NOFS	TEOML	THR	THMS	TFS	TEOM	TZSD	TCRCD
0111	THBSE	TBSE8	TBSE7	TBSE6	TBSE5	TBSE4	TBSE3	TBSE2	TBSE1
0113	THC2	TABT TABT	SBOC -	THCEN THCEN	THCS4 THCS4	THCS3 THCS3	THCS2 THCS2	THCS1 THCS1	THCS0 THCS0
0118	SSIE1	CH8	CH7	CH6	CH5	CH4	CH3	CH2	CH1
0119	SSIE2	CH16	CH15	CH14	CH13	CH12	CH11	CH10	CH9
011A	SSIE3	CH24	CH23	CH22	CH21	CH20	CH19	CH18	CH17
011B	SSIE4	-	-	-	-	-	-	-	-
		<i>CH32</i>	<i>CH31</i>	<i>CH30</i>	<i>CH29</i>	<i>CH28</i>	<i>CH27</i>	<i>CH26</i>	<i>CH25</i>
0120	TIDR1	C7	C6	C5	C4	C3	C2	C1	C0
0121	TIDR2	C7	C6	C5	C4	C3	C2	C1	C0
0122	TIDR3	C7	C6	C5	C4	C3	C2	C1	C0
0123	TIDR4	C7	C6	C5	C4	C3	C2	C1	C0
0124	TIDR5	C7	C6	C5	C4	C3	C2	C1	C0
0125	TIDR6	C7	C6	C5	C4	C3	C2	C1	C0
0126	TIDR7	C7	C6	C5	C4	C3	C2	C1	C0
0127	TIDR8	C7	C6	C5	C4	C3	C2	C1	C0
0128	TIDR9	C7	C6	C5	C4	C3	C2	C1	C0
0129	TIDR10	C7	C6	C5	C4	C3	C2	C1	C0
012A	TIDR11	C7	C6	C5	C4	C3	C2	C1	C0
012B	TIDR12	C7	C6	C5	C4	C3	C2	C1	C0
012C	TIDR13	C7	C6	C5	C4	C3	C2	C1	C0

ADDR	NAME	BIT 7	BIT 6	BIT 5	BIT 4	BIT 3	BIT 2	BIT 1	BIT 0
012D	TIDR14	C7	C6	C5	C4	C3	C2	C1	C0
012E	TIDR15	C7	C6	C5	C4	C3	C2	C1	C0
012F	TIDR16	C7	C6	C5	C4	C3	C2	C1	C0
0130	TIDR17	C7	C6	C5	C4	C3	C2	C1	C0
0131	TIDR18	C7	C6	C5	C4	C3	C2	C1	C0
0132	TIDR19	C7	C6	C5	C4	C3	C2	C1	C0
0133	TIDR20	C7	C6	C5	C4	C3	C2	C1	C0
0134	TIDR21	C7	C6	C5	C4	C3	C2	C1	C0
0135	TIDR22	C7	C6	C5	C4	C3	C2	C1	C0
0136	TIDR23	C7	C6	C5	C4	C3	C2	C1	C0
0137	TIDR24	C7	C6	C5	C4	C3	C2	C1	C0
0138	TIDR25	- C7	- C6	- C5	- C4	- C3	- C2	- C1	- C0
0139	TIDR26	- C7	- C6	- C5	- C4	- C3	- C2	- C1	- C0
013A	TIDR27	- C7	- C6	- C5	- C4	- C3	- C2	- C1	- C0
013B	TIDR28	- C7	- C6	- C5	- C4	- C3	- C2	- C1	- C0
013C	TIDR29	- C7	- C6	- C5	- C4	- C3	- C2	- C1	- C0
013D	TIDR30	- C7	- C6	- C5	- C4	- C3	- C2	- C1	- C0
013E	TIDR31	- C7	- C6	- C5	- C4	- C3	- C2	- C1	- C0
013F	TIDR32	- C7	- C6	- C5	- C4	- C3	- C2	- C1	- C0
0140	TS1	CH1-A 0	CH1-B 0	CH1-C 0	CH1-D 0	CH13-A X	CH13-B Y	CH13-C X	CH13-D X
0141	TS2	CH2-A CH1-A	CH2-B CH1-B	CH2-C CH1-C	CH2-D CH1-D	CH14-A CH16-A	CH14-B CH16-B	CH14-C CH16-C	CH14-D CH16-D
0142	TS3	CH3-A CH2-A	CH3-B CH2-B	CH3-C CH2-C	CH3-D CH2-D	CH15-A CH17-A	CH15-B CH17-B	CH15-C CH17-C	CH15-D CH17-D
0143	TS4	CH4-A CH3-A	CH4-B CH3-B	CH4-C CH3-C	CH4-D CH3-D	CH16-A CH18-A	CH16-B CH18-B	CH16-C CH18-C	CH16-D CH18-D
0144	TS5	CH5-A CH4-A	CH5-B CH4-B	CH5-C CH4-C	CH5-D CH4-D	CH17-A CH19-A	CH17-B CH19-B	CH17-C CH19-C	CH17-D CH19-D
0145	TS6	CH6-A CH5-A	CH6-B CH5-B	CH6-C CH5-C	CH6-D CH5-D	CH18-A CH20-A	CH18-B CH20-B	CH18-C CH20-C	CH18-D CH20-D
0146	TS7	CH7-A CH6-A	CH7-B CH6-B	CH7-C CH6-C	CH7-D CH6-D	CH19-A CH21-A	CH19-B CH21-B	CH19-C CH21-C	CH19-D CH21-D
0147	TS8	CH8-A CH7-A	CH8-B CH7-B	CH8-C CH7-C	CH8-D CH7-D	CH20-A CH22-A	CH20-B CH22-B	CH20-C CH22-C	CH20-D CH22-D
0148	TS9	CH9-A CH8-A	CH9-B CH8-B	CH9-C CH8-C	CH9-D CH8-D	CH21-A CH23-A	CH21-B CH23-B	CH21-C CH23-C	CH21-D CH23-D
0149	TS10	CH10-A CH9-A	CH10-B CH9-B	CH10-C CH9-C	CH10-D CH9-D	CH22-A CH24-A	CH22-B CH24-B	CH22-C CH24-C	CH22-D CH24-D
014A	TS11	CH11-A CH10-A	CH11-B CH10-B	CH11-C CH10-C	CH11-D CH10-D	CH23-A CH25-A	CH23-B CH25-B	CH23-C CH25-C	CH23-D CH25-D
014B	TS12	CH12-A CH11-A	CH12-B CH11-B	CH12-C CH11-C	CH12-D CH11-D	CH24-A CH26-A	CH24-B CH26-B	CH24-C CH26-C	CH24-D CH26-D
014C	TS13	- CH12-A	- CH12-B	- CH12-C	- CH12-D	- CH27-A	- CH27-B	- CH27-C	- CH27-D
014D	TS14	- CH13-A	- CH13-B	- CH13-C	- CH13-D	- CH28-A	- CH28-B	- CH28-C	- CH28-D
014E	TS15	- CH14-A	- CH14-B	- CH14-C	- CH14-D	- CH29-A	- CH29-B	- CH29-C	- CH29-D
014F	TS16	- CH15-A	- CH15-B	- CH15-C	- CH15-D	- CH30-A	- CH30-B	- CH30-C	- CH30-D
0150	TCICE1	CH8	CH7	CH6	CH5	CH4	CH3	CH2	CH1
0151	TCICE2	CH16	CH15	CH14	CH13	CH12	CH11	CH10	CH9
0152	TCICE3	CH24	CH23	CH22	CH21	CH20	CH19	CH18	CH17

ADDR	NAME	BIT 7	BIT 6	BIT 5	BIT 4	BIT 3	BIT 2	BIT 1	BIT 0
0153	TCICE4	- CH32	- CH31	- CH30	- CH29	- CH28	- CH27	- CH26	- CH25
0162	T1TFDL	CH8 -	CH7 -	CH6 -	CH5 -	CH4 -	CH3 -	CH2 -	CH1 -
0163	T1TBOC	- -	- -	TBOC5 -	TBOC4 -	TBOC3 -	TBOC2 -	TBOC1 -	TBOC0 -
0164	T1TSLC1 E1TAF	C8 Si	C7 0	C6 0	C5 1	C4 1	C3 0	C2 1	C1 1
0165	T1TSLC2 E1TNAF	M2 Si	M1 1	S=0 A	S=1 Sa4	S=0 Sa5	C11 Sa6	C10 Sa7	C9 Sa8
0166	T1TSLC3 E1TSiAF	S=1 TSiF14	S4 TSiF12	S3 TSiF10	S2 TSiF8	S1 TSiF6	A2 TSiF4	A1 TSiF2	M3 TSiF0
0167	E1TSiNAF	- TSiF15	- TSiF13	- TSiF11	- TSiF9	- TSiF7	- TSiF5	- TSiF3	- TSiF1
0168	E1TRA	- TRAF15	- TRAF13	- TRAF11	- TRAF9	- TRAF7	- TRAF5	- TRAF3	- TRAF1
0169	E1TSa4	- TSa4F15	- TSa4F13	- TSa4F11	- TSa4F9	- TSa4F7	- TSa4F5	- TSa4F3	- TSa4F1
016A	E1TSa5	- TSa5F15	- TSa5F13	- TSa5F11	- TSa5F9	- TSa5F7	- TSa5F5	- TSa5F3	- TSa5F1
016B	E1TSa6	- TSa6F15	- TSa6F13	- TSa6F11	- TSa6F9	- TSa6F7	- TSa6F5	- TSa6F3	- TSa6F1
016C	E1TSa7	- TSa7F15	- TSa7F13	- TSa7F11	- TSa7F9	- TSa7F7	- TSa7F5	- TSa7F3	- TSa7F1
016D	E1TSa8	- TSa8F15	- TSa8F13	- TSa8F11	- TSa8F9	- TSa8F7	- TSa8F5	- TSa8F3	- TSa8F1
0180	IMMR	FRM_EN	INIT_DONE	-	-	-	-	SFTRST	T1/E1
0181	TCR1	TJC TTPT	TFPT T16S	TCPT TG802	TSSE TSiS	GB7S TSA1	TB8ZS THDB3	TAIS TAIS	TRAI TCRC4
0182	TCR2	TFDLS AEBE	TSLC96 AAIS	- ARA	FBCT2 Sa4S	FBCT1 Sa5S	TD4RM Sa6S	PDE Sa7S	TB7ZS Sa8S
0183	TCR3	ODF ODF	ODM ODM	TCSS1 TCSS1	TCSS0 TCSS0	MFRS MFRS	TFM -	IBPV IBPV	TLOOP CRC4R
0184	TIOCR	TCLKINV TCLKINV	TSYNCINV TSYNCINV	TSSYNCINV TSSYNCINV	TSCLKM TSCLKM	TSSM TSSM	TSIO TSIO	TSDW -	TSM TSM
0185	TESCR	TDATFMT	TGCLKEN	--	TSZS	TESALGN	TESR	TESMDM	TESE
0186	TCR4	- -	- -	- -	- -	TRAIM -	TAISM -	TC1 -	TC0 -
0187	THFC	-	-	-	-	-	-	TFLWM1	TFLWM2
0188	TIBOC	-	IBS1	IBS0	IBOSEL	IBOEN	DA2	DA1	DA0
0189	TDS0SEL	-	-	-	TCM4	TCM3	TCM2	TCM1	TCM0
018A	TXPC	THPBMS	THPBEN	THPAMS	THPAEN	-	TBPDIR	TBPFUS	TBPEN
018B	TBPBS	BPBSE8	BPBSE7	BPBSE6	BPBSE5	BPBSE4	BPBSE3	BPBSE2	BPBSE1
018E	TSYNCC	- -	- -	- -	- -	CRC4 CRC4	TSEN TSEN	SYNCE SYNCE	RESYNC RESYNC
0190	TLS1	TESF TESF	TESEM TESEM	TSLIP TSLIP	TSLC96 -	TPDV TAF	TMF TMF	LOTCC LOTCC	LOTCC LOTCC
0191	TLS2	- -	- -	- -	TFDLE -	TUDR TUDR	TMEND TMEND	TLWMS TLWMS	TNFS TNFS
0192	TLS3	-	-	-	-	-	-	LOF	LOFD
019F	TIIR	-	-	-	-	-	TLS3	TLS2	TLS1
01A0	TIM1	TESF TESF	TESEM TESEM	TSLIP TSLIP	TSLC96 -	TPDV TAF	TMF TMF	LOTCC LOTCC	LOTCC LOTCC
01A1	TIM2	- -	- -	- -	TFDLE -	TUDR TUDR	TMEND TMEND	TLWMS TLWMS	TNFS TNFS
01A2	TIM3	-	-	-	-	-	-	-	LOFD
01AC	T1TCD1	C7 -	C6 -	C5 -	C4 -	C3 -	C2 -	C1 -	C0 -
01AD	T1TCD2	C7 -	C6 -	C5 -	C4 -	C3 -	C2 -	C1 -	C0 -
01B1	IRTS2	-	-	-	-	EMPTY	TFULL	TLWM	TNF

ADDR	NAME	BIT 7	BIT 6	BIT 5	BIT 4	BIT 3	BIT 2	BIT 1	BIT 0
01B3	TFBA	--	TFBA6	TFBA5	TFBA4	TFBA3	TFBA2	TFBA1	TFBA0
01B4	THF	THD7	THD6	THD5	THD4	THD3	THD2	THD1	THD0
01BB	TDS0M	B1	B2	B3	B4	B5	B6	B7	B8
01C0	TBCS1	CH8	CH7	CH6	CH5	CH4	CH3	CH2	CH1
01C1	TBCS2	CH16	CH15	CH14	CH13	CH12	CH11	CH10	CH9
01C2	TBCS3	CH24	CH23	CH22	CH21	CH20	CH19	CH18	CH17
01C3	TBCS4	- <i>CH32</i>	- <i>CH31</i>	- <i>CH30</i>	- <i>CH29</i>	- <i>CH28</i>	- <i>CH27</i>	- <i>CH26</i>	- <i>CH25</i>
01C4	TCBR1	CH8	CH7	CH6	CH5	CH4	CH3	CH2	CH1
01C5	TCBR2	CH16	CH15	CH14	CH13	CH12	CH11	CH10	CH9
01C6	TCBR3	CH24	CH23	CH22	CH21	CH20	CH19	CH18	CH17
01C7	TCBR4	- <i>CH32</i>	- <i>CH31</i>	- <i>CH30</i>	- <i>CH29</i>	- <i>CH28</i>	- <i>CH27</i>	- <i>CH26</i>	- <i>CH25:Fbit</i>
01C8	THSCS1	CH8	CH7	CH6	CH5	CH4	CH3	CH2	CH1
01C9	THSCS2	CH16	CH15	CH14	CH13	CH12	CH11	CH10	CH9
01CA	THSCS3	CH24	CH23	CH22	CH21	CH20	CH19	CH18	CH17
01CB	THSCS4	- <i>CH32</i>	- <i>CH31</i>	- <i>CH30</i>	- <i>CH29</i>	- <i>CH28</i>	- <i>CH27</i>	- <i>CH26</i>	- <i>CH25</i>
01CC	TGCCS1	CH8	CH7	CH6	CH5	CH4	CH3	CH2	CH1
01CD	TGCCS2	CH16	CH15	CH14	CH13	CH12	CH11	CH10	CH9
01CE	TGCCS3	CH24	CH23	CH22	CH21	CH20	CH19	CH18	CH17
01CF	TGCCS4	- <i>CH32</i>	- <i>CH31</i>	- <i>CH30</i>	- <i>CH29</i>	- <i>CH28</i>	- <i>CH27</i>	- <i>CH26</i>	- <i>CH25:Fbit</i>
01D0	PCL1	CH8	CH7	CH6	CH5	CH4	CH3	CH2	CH1
01D1	PCL2	CH16	CH15	CH14	CH13	CH12	CH11	CH10	CH9
01D2	PCL3	CH24	CH23	CH22	CH21	CH20	CH19	CH18	CH17
01D3	PCL4	- <i>CH32</i>	- <i>CH31</i>	- <i>CH30</i>	- <i>CH29</i>	- <i>CH28</i>	- <i>CH27</i>	- <i>CH26</i>	- <i>CH25</i>
01D4	TBPCS1	CH8	CH7	CH6	CH5	CH4	CH3	CH2	CH1
01D5	TBPCS2	CH16	CH15	CH14	CH13	CH12	CH11	CH10	CH9
01D6	TBPCS3	CH24	CH23	CH22	CH21	CH20	CH19	CH18	CH17
01D7	TBPCS4	- <i>CH32</i>	- <i>CH31</i>	- <i>CH30</i>	- <i>CH29</i>	- <i>CH28</i>	- <i>CH27</i>	- <i>CH26</i>	- <i>CH25</i>

10.2.3 LIU Register Bit Map

Table 10-8. LIU Register Bit Map

ADDR	NAME	BIT 7	BIT 6	BIT 5	BIT 4	BIT 3	BIT 2	BIT 1	BIT 0
1000	LTRCR	--	--	--	JADS	JAPS1	JAPS0	T1J1E1S	LSC
1001	LTITSR	--	TIMPTOFF	TIMPL1	TIMPL0	--	TS2	TS1	TS0
1002	LMCR	TAIS	ATAIS	LLB	ALB	RLB	TPDE	RPDE	TXEN
1003	LRSR	--	--	OEQ	UEQ	--	SCS	OCS	LOSS
1004	LSIMR	JALTRSIM	OCSRIM	SCSRIM	LOSRLM	JALTSSIM	OCSSIM	SCSSIM	LOSSIM
1005	LLSR	JFLTRLS	OCRLS	SCRLS	LOSRLS	JALTSLS	OCCLS	SCCLS	LOSSLS
1006	LRSL	RSL3	RSL2	RLS1	RLS0	--	--	--	--
1007	LRISMR	RG703	RIMPOFF	RIMPM1	RIMPM0	RTR	RMONEN	RSMS1	RSMS0

10.2.4 BERT Register Bit Map

Table 10-9. BERT Register Bit Map

ADDR	NAME	BIT 7	BIT 6	BIT 5	BIT 4	BIT 3	BIT 2	BIT 1	BIT 0
1100	BAWC	ACNT7	ACNT6	ACNT5	ACNT4	ACNT3	ACNT2	ACNT1	ACNT0
1101	BRP1	RPAT7	RPAT6	RPAT5	RPAT4	RPAT3	RPAT2	RPAT1	RPAT0
1102	BRP2	RPAT15	RPAT14	RPAT13	RPAT12	RPAT11	RPAT10	RPAT9	RPAT8
1103	BRP3	RPAT23	RPAT22	RPAT21	RPAT20	RPAT19	RPAT18	RPAT17	RPAT16
1104	BRP4	RPAT31	RPAT30	RPAT29	RPAT28	RPAT27	RPAT26	RPAT25	RPAT24
1105	BC1	TC	TINV	RINV	PS2	PS1	PS0	LC	RESYNC
1106	BC2	EIB2	EIB1	EIB0	SBE	RPL3	RPL2	RPL1	RPL0
1107	BBC1	BBC7	BBC6	BBC5	BBC4	BBC3	BBC2	BBC1	BBC0
1108	BBC2	BBC15	BBC14	BBC13	BBC12	BBC11	BBC10	BBC9	BBC8
1109	BBC3	BBC23	BBC22	BBC21	BBC20	BBC19	BBC18	BBC17	BBC16
110A	BBC4	BBC31	BBC30	BBC29	BBC28	BBC27	BBC26	BBC25	BBC24
110B	BEC1	EC7	EC6	EC5	EC4	EC3	EC2	EC1	EC0
110C	BEC2	EC15	EC14	EC13	EC12	EC11	EC10	EC9	EC8
110D	BEC3	EC23	EC22	EC21	EC20	EC19	EC18	EC17	EC16
110E	BLSR	-	BBED	BBCO	BEC0	BRA1	BRA0	BRLOS	BSYNC
110F	BSIM	-	BBED	BBCO	BEC0	BRA1	BRA0	BRLOS	BSYNC

10.3 Global Register Definitions

Functions contained in the global registers include: framer reset, LIU reset, device ID, BERT interrupt status, framer interrupt status, IBO configuration, MCLK configuration, and BPCLK configuration. The global registers bit descriptions are presented below.

Register Name **GTCR1**
 Register Description: **Global Transceiver Control Register 1**
 Register Address: **0F0H**
 Read/Write Function **R/W**

Bit #	7	6	5	4	3	2	1	0
Name	--	--	RLOFLTS	GIBO	--	BWE	GCLE	GIPI
Default	0	0	0	0	0	0	0	0

Bit 5 : Receive Loss Of Frame / Loss of Transmit Clock Indication Select (RLOFLTS).

- 0 = RLOF/LOTcx pins indicate framer receive loss of frame
- 1 = RLOF/LOTcx pins indicate framer loss of transmit clock

Bit 4 : Ganged IBO Enable (GIBO). This bit is used to select either the internal mux for IBO operation or an external “wire-OR” operation. Normally this bit should be set = 0 and the internal mux used.

- 0 = Use internal IBO mux.
- 1 = Externally “wire-OR” TSERs and RSERs for IBO operation.

Bits 2 : Bulk Write Enable (BWE). When this bit is set, a port write to one of the octal ports will be mapped into all eight ports. This applies to the framer, BERT and LIU register sets. It must be cleared before performing a read operation. This bit is useful for device initialization.

- 0 = Normal operation
- 1 = Bulk write is enabled

Bit 1 : Global Counter Latch Enable (GCLE). A low-to-high transition on this bit will, when enabled, latch the framer performance monitor counters. Each framer can be independently enabled to accept this input. This bit must be cleared and set again to perform another counter latch.

Bit 0 : Global Interrupt Pin Inhibit (GIPI).

- 0 = Normal Operation. Interrupt pin (\overline{INT}) will toggle low on an un-masked interrupt condition
- 1 = Interrupt Inhibit. Interrupt pin (\overline{INT}) is forced high (inactive) when this bit is set.

Register Name: **GFCR**
 Description: **Global Framer Control Register**
 Register Address: **0F1H**
 Read/Write Function: **R/W**

Bit #	7	6	5	4	3	2	1	0
Name	IBOMS1	IBOMS0	BPCLK1	BPCLK0	RFLOSSFS	RFMSS	TCBCS	RCBCS
Default	0	0	0	0	0	0	0	0

Bits 7, 6 : Interleave Bus Operation Mode Select 1, 0 (IBOMS[1:0]). These bits determine the configuration of the IBO (interleaved bus) multiplexer. These bits should be used in conjunction with the Rx and Tx IBO control registers within each of the framer units. Additional information concerning the IBO multiplexer is given in Section [9.8.2](#).

IBOMS1	IBOMS0	IBO Mode
0	0	IBO Multiplexer Disabled
0	1	2 devices on bus (4.096MHz)
1	0	4 devices on bus (8.192MHz)
1	1	8 devices on bus (16.384MHz)

Bits 5, 4 : Backplane Clock Select 1, 0 (BPCLK[1:0]). These bits determine the clock frequency output on the BPCLK pin.

BPCLK1	BPCLK0	BPCLK Frequency
0	0	2.048MHz
0	1	4.096MHz
1	0	8.192MHz
1	1	16.384MHz

Bit 3 : Receive Loss of Signal / Signaling Freeze Select (RLOSSFS). This bit controls the function of all eight AL/RSIGF/FLOS pins. The Receive LOS is further selected between Framer LOS and LIU LOS by [GTCR2](#) Bit 2.

0 = AL/RSIGF/FLOS pins output RLOS (1-8) (Receive Loss)

1 = AL/RSIGF/FLOS pins output RSIGF (1-8) (Receive Signaling Freeze)

Bit 2 : Receive Frame/Multiframe Sync Select (RFMSS). This bit controls the function of all eight RM/RFSYNC pins.

0 = RM/RFSYNC pins output RFSYNC (1-8) (Receive Frame Sync)

1 = RM/RFSYNC pins output RMSYNC (1-8) (Receive Multi-Frame Sync)

Bit 1 : Transmit Channel Block/Clock Select (TCBCS). This bit controls the function of all eight TCHBLK/CLK pins.

0 = TCHBLK/CLK pins output TCHBLK (1-8) (Transmit Channel Block)

1 = TCHBLK/CLK pins output TCHCLK (1-8) (Transmit Channel Clock)

Bit 0 : Receive Channel Block/Clock Select (RCBCS). This bit controls the function of all eight RCHBLK/CLK pins.

0 = RCHBLK/CLK pins output RCHBLK (1-8) (Receive Channel Block)

1 = RCHBLK/CLK pins output RCHCLK (1-8) (Receive Channel Clock)

Register Name: **GTCR2**
 Register Description: **Global Transceiver Control Register 2**
 Register Address: **0F2H**
 Read/Write Function: **R/W**

Bit #	7	6	5	4	3	2	1	0
Name	--	--	--	--	--	LOSS	TSSYNIOSEL	--
Default	0	0	0	0	0	0	0	0

Bit 2 : LOS Selection. If this bit is set, the AL/RSIGF/FLOS pins can be driven with LIU Loss and if reset by Framer LOS . The selection of whether to drive AL/RSIGF/FLOS pins with LOS(Analog or Digital) or Signalling Freeze is controlled by [GFCR](#) bit 2. This selection effects all ports

Bit 1 : Transmit System Synchronization I/O Select (TSSYNIOSEL). If this bit is set to a 1 the TSSYNIO is an 8kHz output synchronous to the BPCLK. This “frame pulse” can be used in conjunction with the Backplane clock to provide IBO signals for a System Backplane. If this bit is reset TSSYNIO is an input. An 8kHz frame pulse is required for Transmit Synchronization and IBO operation

Register Name: **GTCCR**
 Register Description: **Global Transceiver Clock Control Register**
 Register Address: **0F3H**
 Read/Write Function: **R/W**

Bit #	7	6	5	4	3	2	1	0
Name	BPREFSEL3	BPREFSEL2	BPREFSEL1	BPREFSEL0	BFREQSEL	FREQSEL	MPS1	MPS0
Default	0	0	0	0	0	0	0	0

Bits 7 to 4 : Backplane Clock Reference Selects (BPREFSEL[3:0]). These bits select which reference clock source will be used for BPCLK generation. The BPCLK can be generated from any of the LIU recovered clocks, an external reference or derivatives of MCLK input. This is shown in [Table 10-10](#). See [Figure 9-1](#) for additional information.

Bit 3 : Backplane Frequency Select. In conjunction with BPRFSEL[3:0] identifies the reference clock frequency used by the DS26528 backplane clock generation circuit. Note that the setting of this bit should match the T1E1 selection for the LIU whose recovered clock is being used to generate the backplane clock. See [Figure 9-1](#) for additional information.

- 0 = Backplane reference clock is 2.048MHz.
- 1 = Backplane reference clock is 1.544MHz.

Bit 2 : Frequency Selection (FREQSEL). In conjunction with the MPS[1:0] bits, selects the external MCLK frequency of the signal input at the MCLK pin of the DS26528.

- 0 = The external master clock is 2.048MHz or multiple thereof.
- 1 = The external master clock is 1.544MHz or multiple thereof.

Bits 1, 0 : Master Period Select 1, 0 (MPS[1:0]). In conjunction with the FREQSEL bit, these bits select the external MCLK frequency of the signal input at the MCLK pin of the DS26528. This is shown in [Table 10-11](#).

Table 10-10. Backplane Reference Clock Select

BPREFSEL3	BPREFSEL2	BPREFSEL1	BPREFSEL0	BFREQSEL	REFERENCE CLOCK SOURCE
0	0	0	0	0	2.048MHz RCLK1
0	0	0	0	1	1.544MHz RCLK1
0	0	0	1	0	2.048MHz RCLK2
0	0	0	1	1	1.544MHz RCLK2
0	0	1	0	0	2.048MHz RCLK3
0	0	1	0	1	1.544MHz RCLK3
0	0	1	1	0	2.048MHz RCLK4
0	0	1	1	1	1.544MHz RCLK4
0	1	0	0	0	2.048MHz RCLK5
0	1	0	0	1	1.544MHz RCLK5
0	1	0	1	0	2.048MHz RCLK6
0	1	0	1	1	1.544MHz RCLK6
0	1	1	0	0	2.048MHz RCLK7
0	1	1	0	1	1.544MHz RCLK7
0	1	1	1	0	2.048MHz RCLK8
0	1	1	1	1	1.544MHz RCLK8
1	0	0	0	1	1.544MHz derived from MCLK. (REFCLKIO is an output)
1	0	0	1	0	2.048MHz derived from MCLK. (REFCLKIO is an output)
1	0	1	0	0	2.048MHz External clock input at REFCLKIO (REFCLKIO is an input)
1	0	1	0	1	1.544MHz External clock input at REFCLKIO (REFCLKIO is an input)

Table 10-11. Master Clock Input Selection

FREQSEL	MPS1	MPS0	MCLK (MHz \pm 50ppm)
0	0	0	2.048
0	0	1	4.096
0	1	0	8.192
0	1	1	16.384
1	0	0	1.544
1	0	1	3.088
1	1	0	6.176
1	1	1	12.352

Register Name: **GLSRR**
 Register Description: **Global LIU Software Reset Register**
 Register Address: **0F5H**
 Read/Write Function: **R/W**

Bit #	7	6	5	4	3	2	1	0
Name	LSRST8	LSRST7	LSRST6	LSRST5	LSRST4	LSRST3	LSRST2	LSRST1
Default	0	0	0	0	0	0	0	0

Bit 7 : Channel 8 LIU Software Reset (LSRST8). LIU logic and registers are reset with a 0-to-1transition in this bit. The reset is released when a zero is written to this bit.

0 = Normal Operation
 1 = Reset LIU

Bit 6: Channel 7 LIU Software Reset (LSRST7). LIU logic and registers are reset with a 0-to-1transition in this bit. The reset is released when a zero is written to this bit.

0 = Normal Operation
 1 = Reset LIU

Bit 5 : Channel 6 LIU Software Reset (LSRST6). LIU logic and registers are reset with a 0-to-1transition in this bit. The reset is released when a zero is written to this bit.

0 = Normal Operation
 1 = Reset LIU

Bit 4 : Channel 5 LIU Software Reset (LSRST5). LIU logic and registers are reset with a 0-to-1transition in this bit. The reset is released when a zero is written to this bit.

0 = Normal Operation
 1 = Reset LIU

Bit 3 : Channel 4 LIU Software Reset (LSRST4). LIU logic and registers are reset with a 0-to-1transition in this bit. The reset is released when a zero is written to this bit.

0 = Normal Operation
 1 = Reset LIU

Bit 2 : Channel 3 LIU Software Reset (LSRST3). LIU logic and registers are reset with a 0-to-1transition in this bit. The reset is released when a zero is written to this bit.

0 = Normal Operation
 1 = Reset LIU

Bit 1 : Channel 2 LIU Software Reset (LSRST2). LIU logic and registers are reset with a 0-to-1transition in this bit. The reset is released when a zero is written to this bit.

0 = Normal Operation
 1 = Reset LIU.

Bit 0 : Channel 1 LIU Software Reset (LSRST1). LIU logic and registers are reset with a 0-to-1transition in this bit. The reset is released when a zero is written to this bit.

0 = Normal Operation
 1 = Reset LIU

Register Name: **GFSRR**
 Register Description: **Global Framer and BERT Software Reset Register**
 Register Address: **0F6H**
 Read/Write Function: **R/W**

Bit #	7	6	5	4	3	2	1	0
Name	FSRST8	FSRST7	FSRST6	FSRST5	FSRST4	FSRST3	FSRST2	FSRST1
Default	0	0	0	0	0	0	0	0

Bit 7 : Channel 8 Framer and BERT Software Reset (FSRST8). Framer logic and registers are reset with a 0-to-1 transition in this bit. The reset is released when a zero is written to this bit.

0 = Normal Operation

1 = Reset Framer and BERT

Bit 6: Channel 7 Framer and BERT Software Reset (FSRST7). Framer logic and registers are reset with a 0-to-1 transition in this bit. The reset is released when a zero is written to this bit.

0 = Normal Operation

1 = Reset Framer and BERT

Bit 5 : Channel 6 Framer and BERT Software Reset (FSRST6). Framer logic and registers are reset with a 0-to-1 transition in this bit. The reset is released when a zero is written to this bit.

0 = Normal Operation

1 = Reset Framer and BERT

Bit 4 : Channel 5 Framer and BERT Software Reset (FSRST5). Framer logic and registers are reset with a 0-to-1 transition in this bit. The reset is released when a zero is written to this bit.

0 = Normal Operation

1 = Reset Framer and BERT

Bit 3 : Channel 4 Framer and BERT Software Reset (FSRST4). Framer logic and registers are reset with a 0-to-1 transition in this bit. The reset is released when a zero is written to this bit.

0 = Normal Operation

1 = Reset Framer and BERT

Bit 2 : Channel 3 Framer and BERT Software Reset (FSRST3). Framer logic and registers are reset with a 0-to-1 transition in this bit. The reset is released when a zero is written to this bit.

0 = Normal Operation

1 = Reset Framer and BERT

Bit 1 : Channel 2 Framer and BERT Software Reset (FSRST2). Framer logic and registers are reset with a 0-to-1 transition in this bit. The reset is released when a zero is written to this bit.

0 = Normal Operation

1 = Reset Framer and BERT

Bit 0 : Channel 1 Framer and BERT Software Reset (FSRST1). Framer logic and registers are reset with a 0-to-1 transition in this bit. The reset is released when a zero is written to this bit.

0 = Normal Operation

1 = Reset Framer and BERT

Register Name: **IDR**
 Register Description: **Device Identification Register**
 Register Address: **0F8H**
 Read/Write Function: **R**

Bit #	7	6	5	4	3	2	1	0
Name	ID7	ID6	ID5	ID4	ID3	ID2	ID1	ID0
Default	0	1	0	1	1	0	0	1

Bits 7 to 3: Device ID (ID3 to ID7). The upper five bits of the IDR are used to display the DS26528 ID.

Table 10-12. Device ID Codes in this Product Family

DEVICE	ID7	ID6	ID5	ID4	ID3
DS26528	0	1	0	1	1
DS26524	0	1	1	0	0
DS26522	0	1	1	0	1
DS26521	0	1	1	1	0

Bits 2 to 0: Silicon Revision Bits (ID0 to ID2). The lower three bits of the IDR are used to display a sequential number denoting the die revision of the chip. The initial silicon revision = "000", and is incremented with each silicon revision. This value is not the same as the two-character device revision on the top brand of the device. This is due to the fact that portions of the device assembly other than the silicon may change, causing the device revision increment on the brand without having a revision of the silicon. ID0 is the LSB of a decimal code that represents the chip revision.

Register Name: **GFISR**
 Register Description: **Global Framer Interrupt Status Register**
 Register Address: **0F9H**
 Read/Write Function: **R**

Bit #	7	6	5	4	3	2	1	0
Name	FIS8	FIS7	FIS6	FIS5	FIS4	FIS3	FIS2	FIS1
Default	0	0	0	0	0	0	0	0

The GFISR register reports the framer interrupt status for each of the 8 T1/E1 framers. A logic one in the associated bit location indicates a framer has set its interrupt signal.

Bit 7 : Framer Interrupt Status 8 (FIS8).

0 = Framer 8 has not issued an interrupt.
 1 = Framer 8 has issued an interrupt.

Bit 6 : Framer Interrupt Status 7 (FIS7).

0 = Framer 7 has not issued an interrupt.
 1 = Framer 7 has issued an interrupt.

Bit 5 : Framer Interrupt Status 6 (FIS6).

0 = Framer 6 has not issued an interrupt.
 1 = Framer 6 has issued an interrupt.

Bit 4 : Framer Interrupt Status 5 (FIS5).

0 = Framer 5 has not issued an interrupt.
 1 = Framer 5 has issued an interrupt.

Bit 3 : Framer Interrupt Status 4 (FIS4).

0 = Framer 4 has not issued an interrupt.
 1 = Framer 4 has issued an interrupt.

Bit 2 : Framer Interrupt Status 3 (FIS3).

0 = Framer 3 has not issued an interrupt.
 1 = Framer 3 has issued an interrupt.

Bit 1 : Framer Interrupt Status 2 (FIS2).

0 = Framer 2 has not issued an interrupt.
 1 = Framer 2 has issued an interrupt.

Bit 0 : Framer Interrupt Status 1(FIS1).

0 = Framer 1 has not issued an interrupt.
 1 = Framer 1 has issued an interrupt.

Register Name: **GBISR**
 Register Description: **Global BERT Interrupt Status Register**
 Register Address: **0FAH**
 Read/Write Function: **R**

Bit #	7	6	5	4	3	2	1	0
Name	BIS8	BIS7	BIS6	BIS5	BIS4	BIS3	BIS2	BIS1
Default	0	0	0	0	0	0	0	0

The GBISR register reports the interrupt status for each of the 8 T1/E1 bit error rate testers (BERT). A logic one in the associated bit location indicates a BERT has set its interrupt signal.

Bit 7 : BERT Interrupt Status 8

0 = BERT 8 has not issued an interrupt.
 1 = BERT 8 has issued an interrupt.

Bit 6 : BERT Interrupt Status 7

0 = BERT 7 has not issued an interrupt.
 1 = BERT 7 has issued an interrupt.

Bit 5 : BERT Interrupt Status 6

0 = BERT 6 has not issued an interrupt.
 1 = BERT 6 has issued an interrupt.

Bit 4 : BERT Interrupt Status 5

0 = BERT 5 has not issued an interrupt.
 1 = BERT 5 has issued an interrupt.

Bit 3 : BERT Interrupt Status 4

0 = BERT 4 has not issued an interrupt.
 1 = BERT 4 has issued an interrupt.

Bit 2 : BERT Interrupt Status 3

0 = BERT 3 has not issued an interrupt.
 1 = BERT 3 has issued an interrupt.

Bit 1 : BERT Interrupt Status 2

0 = BERT 2 has not issued an interrupt.
 1 = BERT 2 has issued an interrupt.

Bit 0 : BERT Interrupt Status 1

0 = BERT 1 has not issued an interrupt.
 1 = BERT 1 has issued an interrupt.

Register Name: **GLISR**
 Register Description: **Global LIU Interrupt Status Register**
 Register Address: **0FBH**
 Read/Write Function: **R**

Bit #	7	6	5	4	3	2	1	0
Name	LIS8	LIS7	LIS6	LIS5	LIS4	LIS3	LIS2	LIS1
Default	0	0	0	0	0	0	0	0

The GLISR register reports the LIU interrupt status for each of the 8 T1/E1 LIUs. A logic one in the associated bit location indicates a LIU has set its interrupt signal.

Bit 7 : LIU Interrupt Status 8

0 = LIU 8 has not issued an interrupt.
 1 = LIU 8 has issued an interrupt.

Bit 6 : LIU Interrupt Status 7

0 = LIU 7 has not issued an interrupt.
 1 = LIU 7 has issued an interrupt.

Bit 5 : LIU Interrupt Status 6

0 = LIU 6 has not issued an interrupt.
 1 = LIU 6 has issued an interrupt.

Bit 4 : LIU Interrupt Status 5

0 = LIU 5 has not issued an interrupt.
 1 = LIU 5 has issued an interrupt.

Bit 3 : LIU Interrupt Status 4

0 = LIU 4 has not issued an interrupt.
 1 = LIU 4 has issued an interrupt.

Bit 2 : LIU Interrupt Status 3

0 = LIU 3 has not issued an interrupt.
 1 = LIU 3 has issued an interrupt.

Bit 1 : LIU Interrupt Status 2

0 = LIU 2 has not issued an interrupt.
 1 = LIU 2 has issued an interrupt.

Bit 0 : LIU Interrupt Status 1

0 = LIU 1 has not issued an interrupt.
 1 = LIU 1 has issued an interrupt.

Register Name: **GFIMR**
 Register Description: **Global Framer Interrupt Mask Register**
 Register Address: **0FCH**
 Read/Write Function: **R/W**

Bit #	7	6	5	4	3	2	1	0
Name	FIM8	FIM7	FIM6	FIM5	FIM4	FIM3	FIM2	FIM1
Default	0	0	0	0	0	0	0	0

Bit 7 : Framer 8 Interrupt Mask (FIM8).

0 = Interrupt masked.
 1 = Interrupt enabled.

Bit 6 : Framer 7 Interrupt Mask (FIM7).

0 = Interrupt masked.
 1 = Interrupt enabled.

Bit 5 : Framer 6 Interrupt Mask (FIM6).

0 = Interrupt masked.
 1 = Interrupt enabled.

Bit 4 : Framer 5 Interrupt Mask (FIM5).

0 = Interrupt masked.
 1 = Interrupt enabled.

Bit 3 : Framer 4 Interrupt Mask (FIM4).

0 = Interrupt masked.
 1 = Interrupt enabled.

Bit 2 : Framer 3 Interrupt Mask (FIM3).

0 = Interrupt masked.
 1 = Interrupt enabled.

Bit 1 : Framer 2 Interrupt Mask (FIM2).

0 = Interrupt masked.
 1 = Interrupt enabled.

Bit 0 : Framer 1 Interrupt Mask (FIM1).

0 = Interrupt masked.
 1 = Interrupt enabled.

Register Name: **GBIMR**
 Register Description: **Global Bert Interrupt Mask Register**
 Register Address: **0FDH**
 Read/Write Function: **R/W**

Bit #	7	6	5	4	3	2	1	0
Name	BIM8	BIM7	BIM6	BIM5	BIM4	BIM3	BIM2	BIM1
Default	0	0	0	0	0	0	0	0

Bit 7 : BERT Interrupt Mask 8

0 = Interrupt masked.
 1 = Interrupt enabled.

Bit 6 : BERT Interrupt Mask 7

0 = Interrupt masked.
 1 = Interrupt enabled.

Bit 5 : BERT Interrupt Mask 6

0 = Interrupt masked.
 1 = Interrupt enabled.

Bit 4 : BERT Interrupt Mask 5

0 = Interrupt masked.
 1 = Interrupt enabled.

Bit 3 : BERT Interrupt Mask 4

0 = Interrupt masked.
 1 = Interrupt enabled.

Bit 2 : BERT Interrupt Mask 3

0 = Interrupt masked.
 1 = Interrupt enabled.

Bit 1 : BERT Interrupt Mask 2

0 = Interrupt masked.
 1 = Interrupt enabled.

Bit 0 : BERT Interrupt Mask 1

0 = Interrupt masked.
 1 = Interrupt enabled.

Register Name: **GLIMR**
 Register Description: **Global LIU Interrupt Mask Register**
 Register Address: **0FEH**
 Read/Write Function: **R/W**

Bit #	7	6	5	4	3	2	1	0
Name	LIM8	LIM7	LIM6	LIM5	LIM4	LIM3	LIM2	LIM1
Default	0	0	0	0	0	0	0	0

Bit 7 : LIU Interrupt Mask 8

0 = Interrupt masked.
 1 = Interrupt enabled.

Bit 6 : LIU Interrupt Mask 7

0 = Interrupt masked.
 1 = Interrupt enabled.

Bit 5 : LIU Interrupt Mask 6

0 = Interrupt masked.
 1 = Interrupt enabled.

Bit 4 : LIU Interrupt Mask 5

0 = Interrupt masked.
 1 = Interrupt enabled.

Bit 3 : LIU Interrupt Mask 4

0 = Interrupt masked.
 1 = Interrupt enabled.

Bit 2 : LIU Interrupt Mask 3

0 = Interrupt masked.
 1 = Interrupt enabled.

Bit 1 : LIU Interrupt Mask 2

0 = Interrupt masked.
 1 = Interrupt enabled.

Bit 0 : LIU Interrupt Mask 1

0 = Interrupt masked.
 1 = Interrupt enabled.

10.4 Framing Register Definitions

10.4.1 Receive Register Definitions

Register Name: **RHC**
 Register Description: **Receive HDLC Control Register**
 Register Address: **010H + (200h x n): where n = 0 to 7, for Ports 1 to 8**

Bit #	7	6	5	4	3	2	1	0
Name	RCRCD	RHR	RHMS	RHCS4	RHCS3	RHCS2	RHCS1	RHCS0
Default	0	0	0	0	0	0	0	0

Bit 7: Receive CRC16 Display (RCRCD).

- 0 = Do not write received CRC16 code to FIFO. (default)
- 1 = Write received CRC16 code to FIFO after last octet of packet.

Bit 6: Receive HDLC Reset (RHR). Will reset the receive HDLC controller and flush the receive FIFO. Note that this bit is a acknowledged reset. The host should set this bit and the DS26528 will clear it once the reset operation is complete. The DS26528 will complete the HDLC reset within 2 frames.

- 0 = Normal operation
- 1 = Reset receive HDLC controller and flush the receive FIFO

Bit 5: Receive HDLC Mapping Select (RHMS).

- 0 = Receive HDLC assigned to channels
- 1 = Receive HDLC assigned to FDL(T1 mode), Sa Bits(E1 mode)

Bit 4 to 0 : Receive HDLC Channel Select 4 to 0 (RHCS[4:0]). These bits determine which DS0 is mapped to the HDLC controller when enabled with RHMS = 0. RHCS0 to RHCS4 = all 0s selects channel 1, RHCS0 to RHCS4 = all 1s selects channel 32 (E1). A change to the receive HDLC channel select is acknowledged only after a Receive HDLC Reset (RHR).

Register Name: **RHBSE**
 Register Description: **Receive HDLC Bit Suppress Register**
 Register Address: **011H + (200h x n); where n = 0 to 7, for Ports 1 to 8**

Bit #	7	6	5	4	3	2	1	0
Name	BSE8	BSE7	BSE6	BSE5	BSE4	BSE3	BSE2	BSE1
Default	0	0	0	0	0	0	0	0

Bit 7 : Receive Channel Bit 8 Suppress (BSE8). MSB of the channel. Set to one to stop this bit from being used.

Bit 6 : Receive Channel Bit 7 Suppress (BSE7). Set to one to stop this bit from being used.

Bit 5 : Receive Channel Bit 6 Suppress (BSE6). Set to one to stop this bit from being used.

Bit 4 : Receive Channel Bit 5 Suppress (BSE5). Set to one to stop this bit from being used.

Bit 3 : Receive Channel Bit 4 Suppress (BSE4). Set to one to stop this bit from being used.

Bit 2 : Receive Channel Bit 3 Suppress (BSE3). Set to one to stop this bit from being used.

Bit 1 : Receive Channel Bit 2 Suppress (BSE2). Set to one to stop this bit from being used.

Bit 0 : Receive Channel Bit 1 Suppress (BSE1). LSB of the channel. Set to one to stop this bit from being used.

Register Name: **RDS0SEL**
 Register Description: **Receive Channel Monitor Select**
 Register Address: **012H + (200h x n): where n = 0 to 7, for Ports 1 to 8**

Bit #	7	6	5	4	3	2	1	0
Name	-	-	-	RCM4	RCM3	RCM2	RCM1	RCM0
Default	0	0	0	0	0	0	0	0

Bits 4 to 0 : Receive Channel Monitor Bits (RCM[4:0]). RCM0 is the LSB of a five bit channel select that determines which receive DS0 channel data will appear in the RDS0M register.

Register Name: **RSIGC**
 Register Description: **Receive Signaling Control Register**
 Register Address: **013H + (200h x n): where n = 0 to 7, for Ports 1 to 8**

Bit #	7	6	5	4	3	2	1	0
Name	-	-	-	RFSA1 CASMS	-	RSFF	RSFE	RSIE
Default	0	0	0	0	0	0	0	0

Bit 4 (T1 Mode): Receive Force Signaling All Ones (RFSA1).

0 = do not force robbed bit signaling to all ones

1 = force signaling bits to all ones on a per-channel basis according to the RSAO11-RSAO13 registers.

Bit 4 (E1 Mode): CAS Mode Select (CASMS).

0 = The DS26528 will initiate a resync when two consecutive multiframe alignment signals have been received with an error.

1 = The DS26528 will initiate a resync when two consecutive multiframe alignment signals have been received with an error, or 1 multiframe has been received with all the bits in time slot 16 in state 0.

Alignment criteria is met when at least one bit in state 1 is present in the time slot 16 preceding the multiframe alignment signal first detected (G.732 alternate criteria).

Bit 2 : Receive Signaling Force Freeze (RSFF). Freezes receive side signaling at RSIG (and RSER if Receive Signaling Reinsertion is enabled); will override Receive Freeze Enable (RFE).

0 = do not force a freeze event

1 = force a freeze event

Bit 1 : Receive Signaling Freeze Enable (RSFE).

0 = no freezing of receive signaling data will occur

1 = allow freezing of receive signaling data at RSIG (and RSER if Receive Signaling Reinsertion is enabled).

Bit 0 : Receive Signaling Integration Enable (RSIE).

0 = signaling changes of state reported on any change in selected channels

1 = signaling must be stable for 3 multiframes in order for a change of state to be reported

Register Name: **T1RCR2**
 Register Description: **Receive Control Register 2**
 Register Address: **014H + (200h x n): where n = 0 to 7, for Ports 1 to 8**

Bit #	7	6	5	4	3	2	1	0
Name	-	-	-	RSLC96	OOF2	OOF1	RAIIE	RD4RM
Default	0	0	0	0	0	0	0	0

Bit 4: Receive SLC-96 Synchronizer Enable (RSLC96). See Section [9.9.4.4](#) for SLC-96 details.

0 = the SLC-96 synchronizer is disabled

1 = the SLC-96 synchronizer is enabled

Bits 3 to 2: Out Of Frame Select Bits (OOF[2:1]).

OOF2	OOF1	OUT OF FRAME CRITERIA
0	0	2/4 frame bits in error
0	1	2/5 frame bits in error
1	0	2/6 frame bits in error
1	1	2/6 frame bits in error

Bit 1: Receive RAI Integration Enable (RAIIE). The ESF RAI indication can be interrupted for a period not to exceed 100ms per interruption (T1.403). In ESF mode, setting RAIIE will cause the RAI status from the DS26528 to be integrated for 200ms.

0 = RAI detects when 16 consecutive patterns of 00FF appear in the FDL.

RAI clears when 14 or less patterns of 00FF hex out of 16 possible appear in the FDL

1 = RAI detects when the condition has been present for greater than 200ms.

RAI clears when the condition has been absent for greater than 200ms.

Bit 0: Receive Side D4 Remote Alarm Select (RD4RM).

0 = zeros in bit 2 of all channels

1 = a one in the S-bit position of frame 12 (J1 Yellow Alarm Mode)

Register Name: **T1RBOCC**
 Register Description: **Receive BOC Control Register**
 Register Address: **015H + (200h x n): where n = 0 to 7, for Ports 1 to 8**

Bit #	7	6	5	4	3	2	1	0
Name	RBR	-	RBD1	RBD0	-	RBF1	RBF0	-
Default	0	0	0	0	0	0	0	0

Bit 7: Receive BOC Reset (RBR). The host should set this bit to force a reset of the BOC circuitry. Note that this is an acknowledged reset – that is the host need only set the bit and the DS26528 will clear it once the reset operation is complete (less than 250us). Modifications to the RBF0, RBF1, RBD0, and RBD1 bits will not be applied to the BOC controller until a BOC reset has been completed.

Bits 5, 4: Receive BOC Disintegration bits (RBD[1:0]). The BOC Disintegration filter sets the number of message bits that must be received without a valid BOC to set the BC bit indicating that a valid BOC is no longer being received.

RBD1	RBD0	CONSECUTIVE MESSAGE BITS FOR BOC CLEAR IDENTIFICATION
0	0	16
0	1	32
1	0	48
1	1	64 ¹

Bits 2, 1: Receive BOC Filter bits (RBF[1:0]). The BOC filter sets the number of consecutive patterns that must be received without error prior to an indication of a valid message.

RBF1	RBF0	CONSECUTIVE BOC CODES FOR VALID SEQUENCE IDENTIFICATION
0	0	None
0	1	3
1	0	5
1	1	7 ¹

Note: The DS26528's BOC controller does not integrate and disintegrate concurrently. Therefore, if the maximum integration time and the maximum disintegration time are used together, BOC messages which repeat fewer than 11 times may not be detected.

Register Name: **RIDR1 to RIDR32**
 Register Description: **Receive Idle Code Definition Registers 1 to 32**
 Register Address: **20H to 3FH + (200h x n): where n = 0 to 7, for Ports 1 to 8**

Bit #	7	6	5	4	3	2	1	0
Name	C7	C6	C5	C4	C3	C2	C1	C0
Default	0	0	0	0	0	0	0	0

Bits 7 to 0: Per-Channel Idle Code Bits (C[7:0]). C0 is the LSB of the Code (this bit is transmitted last). Address 20H is for channel 1. Address 37H is for channel 24. Address 3FH is for channel 32.

Register Name: **T1RSAOI1, T1RSAOI2, T1RSAOI3,**
 Register Description: **Receive Signaling All Ones Insertion Registers**
 Register Address: **038H, 039H, 03AH + (200h x n): where n = 0 to 7, for Ports 1 to 8**

(MSB)							(LSB)	
CH8	CH7	CH6	CH5	CH4	CH3	CH2	CH1	T1RSAOI1
CH16	CH15	CH14	CH13	CH12	CH11	CH10	CH9	T1RSAOI2
CH24	CH23	CH22	CH21	CH20	CH19	CH18	CH17	T1RSAOI3

Setting any of the CH1 through CH24 bits in the RSAOI1 through RSAOI3 registers will cause signaling data to be replaced with logic ones as reported on RSER. The RSIG signal will continue to report received signaling data. Note that this feature must be enabled with control bit RSIGC.4.

Register Name: **T1RDMWE1, T1RDMWE2, T1RDMWE3**
 Register Description: **T1 Receive Digital Milliwatt Enable Registers**
 Register Address: **03CH, 03DH, 03EH + (200h x n): where n = 0 to 7, for Ports 1 to 8**

(MSB)							(LSB)	
CH8	CH7	CH6	CH5	CH4	CH3	CH2	CH1	T1RDMWE1
CH16	CH15	CH14	CH13	CH12	CH11	CH10	CH9	T1RDMWE2
CH24	CH23	CH22	CH21	CH20	CH19	CH18	CH17	T1RDMWE3

Bits 7 to 0: Receive Digital Milliwatt Enable for Channels 1 to 24 (CH1 to CH24).

0 =do not affect the receive data associated with this channel

1 = replace the receive data associated with this channel with digital milliwatt code

Register Name: **RS1 to RS12**
 Register Description: **Receive Signaling Registers**
 Register Address: **040H to 04FH + (200h x n); where n = 0 to 7, for Ports 1 to 8**

T1 Mode:

(MSB)							(LSB)	
CH1-A	CH1-B	CH1-C	CH1-D	CH13-A	CH13-B	CH13-C	CH13-D	RS1
CH2-A	CH2-B	CH2-C	CH2-D	CH14-A	CH14-B	CH14-C	CH14-D	RS2
CH3-A	CH3-B	CH3-C	CH3-D	CH15-A	CH15-B	CH15-C	CH15-D	RS3
CH4-A	CH4-B	CH4-C	CH4-D	CH16-A	CH16-B	CH16-C	CH16-D	RS4
CH5-A	CH5-B	CH5-C	CH5-D	CH17-A	CH17-B	CH17-C	CH17-D	RS5
CH6-A	CH6-B	CH6-C	CH6-D	CH18-A	CH18-B	CH18-C	CH18-D	RS6
CH7-A	CH7-B	CH7-C	CH7-D	CH19-A	CH19-B	CH19-C	CH19-D	RS7
CH8-A	CH8-B	CH8-C	CH8-D	CH20-A	CH20-B	CH20-C	CH20-D	RS8
CH9-A	CH9-B	CH9-C	CH9-D	CH21-A	CH21-B	CH21-C	CH21-D	RS9
CH10-A	CH10-B	CH10-C	CH10-D	CH22-A	CH22-B	CH22-C	CH22-D	RS10
CH11-A	CH11-B	CH11-C	CH11-D	CH23-A	CH23-B	CH23-C	CH23-D	RS11
CH12-A	CH12-B	CH12-C	CH12-D	CH24-A	CH24-B	CH24-C	CH24-D	RS12

E1 MODE:

(MSB)							(LSB)	
0	0	0	0	X	Y	X	X	RS1
CH1-A	CH1-B	CH1-C	CH1-D	CH16-A	CH16-B	CH16-C	CH16-D	RS2
CH2-A	CH2-B	CH2-C	CH2-D	CH17-A	CH17-B	CH17-C	CH17-D	RS3
CH3-A	CH3-B	CH3-C	CH3-D	CH18-A	CH18-B	CH18-C	CH18-D	RS4
CH4-A	CH4-B	CH4-C	CH4-D	CH19-A	CH19-B	CH19-C	CH19-D	RS5
CH5-A	CH5-B	CH5-C	CH5-D	CH20-A	CH20-B	CH20-C	CH20-D	RS6
CH6-A	CH6-B	CH6-C	CH6-D	CH21-A	CH21-B	CH21-C	CH21-D	RS7
CH7-A	CH7-B	CH7-C	CH7-D	CH22-A	CH22-B	CH22-C	CH22-D	RS8
CH8-A	CH8-B	CH8-C	CH8-D	CH23-A	CH23-B	CH23-C	CH23-D	RS9
CH9-A	CH9-B	CH9-C	CH9-D	CH24-A	CH24-B	CH24-C	CH24-D	RS10
CH10-A	CH10-B	CH10-C	CH10-D	CH25-A	CH25-B	CH25-C	CH25-D	RS11
CH11-A	CH11-B	CH11-C	CH11-D	CH26-A	CH26-B	CH26-C	CH26-D	RS12
CH12-A	CH12-B	CH12-C	CH12-D	CH27-A	CH27-B	CH27-C	CH27-D	RS13
CH13-A	CH13-B	CH13-C	CH13-D	CH28-A	CH28-B	CH28-C	CH28-D	RS14
CH14-A	CH14-B	CH14-C	CH14-D	CH29-A	CH29-B	CH29-C	CH29-D	RS15
CH15-A	CH15-B	CH15-C	CH15-D	CH30-A	CH30-B	CH30-C	CH30-D	RS16

In the ESF framing mode, there can be up to four signaling bits per channel (A, B, C, and D). In the D4 framing mode, there are only two signaling bits per channel (A and B). In the D4 framing mode, the framer will repeat the A and B signaling data in the C and D bit locations. Therefore, when the framer is operated in D4 framing mode, the user will need to retrieve the signaling bits every 1.5ms as opposed to 3ms for ESF mode. The Receive Signaling Registers are frozen and not updated during a loss of sync condition. They will contain the most recent signaling information before the "OOF" occurred.

Register Name: **LCVCR1**
 Register Description: **Line Code Violation Count Register 1**
 Register Address: **050H + (200h x n): where n = 0 to 7, for Ports 1 to 8**

Bit #	7	6	5	4	3	2	1	0
Name	LCVC15	LCVC14	LCVC13	LCVC12	LCVC11	LCVC10	LCVC9	LCCV8
Default	0	0	0	0	0	0	0	0

Bits 7 to 0 : Line Code Violation Counter Bits 15 to 8 (LCVC15 to LCVC8). LCV15 is the MSB of the 16-bit code violation count

Register Name: **LCVCR2**
 Register Description: **Line Code Violation Count Register 2**
 Register Address: **051H + (200h x n): where n = 0 to 7, for Ports 1 to 8**

Bit #	7	6	5	4	3	2	1	0
Name	LCVC7	LCVC6	LCVC5	LCVC4	LCVC3	LCVC2	LCVC1	LCVC0
Default	0	0	0	0	0	0	0	0

Bits 7 to 0 : Line Code Violation Counter Bits 7 to 0 (LCVC7 to LCVC0). LCV0 is the LSB of the 16-bit code violation count

Register Name: **PCVCR1**
 Register Description: **Path Code Violation Count Register 1**
 Register Address: **052H + (200h x n): where n = 0 to 7, for Ports 1 to 8**

Bit #	7	6	5	4	3	2	1	0
Name	PCVC15	PCVC14	PCVC13	PCVC12	PCVC11	PCVC10	PCVC9	PCVC8
Default	0	0	0	0	0	0	0	0

Bits 7 to 0 : Path Code Violation Counter Bits 15 to 8 (PCVC15 to PCVC8). PCVC15 is the MSB of the 16-bit path code violation count

Register Name: **PCVCR2**
 Register Description: **Path Code Violation Count Register 2**
 Register Address: **053H + (200h x n): where n = 0 to 7, for Ports 1 to 8**

Bit #	7	6	5	4	3	2	1	0
Name	PCVC7	PCVC6	PCVC5	PCVC4	PCVC3	PCVC2	PCVC1	PCVC0
Default	0	0	0	0	0	0	0	0

Bits 7 to 0: Path Code Violation Counter Bits 0 to 7 (PCVC7 to PCVC0). PCVC0 is the LSB of the 16-bit path code violation count.

Register Name: **FOSCR1**
 Register Description: **Frames Out Of Sync Count Register 1**
 Register Address: **054H + (200h x n): where n = 0 to 7, for Ports 1 to 8**

Bit #	7	6	5	4	3	2	1	0
Name	FOS15	FOS14	FOS13	FOS12	FOS11	FOS10	FOS9	FOS8
Default	0	0	0	0	0	0	0	0

Bits 7 to 0: Frames Out of Sync Counter Bits 15 to 8 (FOS15 to FOS8). FOS15 is the MSB of the 16-bit frames out of sync count.

Register Name: **FOSCR2**
 Register Description: **Frames Out Of Sync Count Register 2**
 Register Address: **055H + (200h x n): where n = 0 to 7, for Ports 1 to 8**

Bit #	7	6	5	4	3	2	1	0
Name	FOS7	FOS6	FOS5	FOS4	FOS3	FOS2	FOS1	FOS0
Default	0	0	0	0	0	0	0	0

Bits 7 to 0: Frames Out of Sync Counter Bits 7 to 0 (FOS7 to FOS0). FOS0 is the LSB of the 16-bit frames out of sync count.

Register Name: **E1BCR1**
 Register Description: **E-Bit Count Register 1**
 Register Address: **056H + (200h x n): where n = 0 to 7, for Ports 1 to 8**

Bit #	7	6	5	4	3	2	1	0
Name	EB15	EB14	EB13	EB12	EB11	EB10	EB9	EB8
Default	0	0	0	0	0	0	0	0

Bits 7 to 0 : E-Bit Counter Bits 15 to 8 (EB[15:8]). EB15 is the MSB of the 16-bit E-Bit count

Register Name: **E1EBCR2**
 Register Description: **E-Bit Count Register 2**
 Register Address: **057H + (200h x n): where n = 0 to 7, for Ports 1 to 8**

Bit #	7	6	5	4	3	2	1	0
Name	EB7	EB6	EB5	EB4	EB3	EB2	EB1	EB0
Default	0	0	0	0	0	0	0	0

Bits 7 to 0 : E-Bit Counter Bits 7 to 0 (EB[7:0]). EB0 is the LSB of the 16-bit E-Bit count

Register Name: **RDS0M**
 Register Description: **Receive DS0 Monitor Register**
 Register Address: **060H + (200h x n): where n = 0 to 7, for Ports 1 to 8**

Bit #	7	6	5	4	3	2	1	0
Name	B1	B2	B3	B4	B5	B6	B7	B8
Default	0	0	0	0	0	0	0	0

Bits 7 to 0: Receive DS0 Channel Bits (B1 to B8). Receive channel data that has been selected by the Receive Channel Monitor Select Register. B8 is the LSB of the DS0 channel (last bit to be received).

Register Name: **E1RFRID**
 Register Description: **Receive Firmware Revision ID Register**
 Register Address: **061H + (200h x n): where n = 0 to 7, for Ports 1 to 8**

Bit #	7	6	5	4	3	2	1	0
Name	FR7	FR6	FR5	FR4	FR3	FR2	FR1	FR0
Default	0	0	0	0	0	0	0	0

Bits 7 to 0 : Firmware Revision (FR[7:0]). This read-only register reports the current revision of the receive firmware.

Register Name: **T1RFDL**
 Register Description: **Receive FDL Register – T1 MODE**
 Register Address: **062H + (200h x n): where n = 0 to 7, for Ports 1 to 8**

Bit #	7	6	5	4	3	2	1	0
Name	RFDL7	RFDL6	RFDL5	RFDL4	RFDL3	RFDL2	RFDL1	RFDL0
Default	0	0	0	0	0	0	0	0

Note: This register has an alternate definition for E1 mode. See [E1RRTS7](#).

Bit 7: Receive FDL Bit 7 (RFDL7). MSB of the Received FDL Code.

Bit 6: Receive FDL Bit 6 (RFDL6).

Bit 5: Receive FDL Bit 5 (RFDL5).

Bit 4: Receive FDL Bit 4 (RFDL4).

Bit 3: Receive FDL Bit 3 (RFDL3).

Bit 2: Receive FDL Bit 2 (RFDL2).

Bit 1: Receive FDL Bit 1 (RFDL1).

Bit 0: Receive FDL Bit 0 (RFDL0). LSB of the Received FDL Code.

Register Name: **E1RRTS7**
 Register Description: **Receive Real-Time Status Register 7 – E1 MODE**
 Register Address: **062H + (200h x n): where n = 0 to 7, for Ports 1 to 8**

Bit #	7	6	5	4	3	2	1	0
Name	CSC5	CSC4	CSC3	CSC2	CSC0	CRC4S A	CASSA	FASSA
Default	0	0	0	0	0	0	0	0

Note: This register has an alternate definition for T1 mode. See [T1RFDL](#). All bits in this register are real-time (not latched).

Bits 7 to 3 : CRC4 Sync Counter Bits (CSC[5:2] & CSC0). The CRC4 Sync Counter increments each time the 8 ms CRC4 multiframe search times out. The counter is cleared when the framer has successfully obtained synchronization at the CRC4 level. The counter can also be cleared by disabling the CRC4 mode (RCR1.3 = 0). This counter is useful for determining the amount of time the framer has been searching for synchronization at the CRC4 level. ITU G.706 suggests that if synchronization at the CRC4 level cannot be obtained within 400 ms, then the search should be abandoned and proper action taken. The CRC4 Sync Counter will saturate (not rollover). CSC0 is the LSB of the 6-bit counter. (Note: The next to LSB is not accessible. CSC1 is omitted to allow resolution to >400ms using 5 bits)

Bit 2 : CRC4 MF Sync Active (CRC4SA). Set while the synchronizer is searching for the CRC4 MF alignment word.

Bit 1 : CAS MF Sync Active (CASSA). Set while the synchronizer is searching for the CAS MF alignment word.

Bit 0 : FAS Sync Active (FASSA). Set while the synchronizer is searching for alignment at the FAS level.

Register Name: **T1RBOC**
 Register Description: **Receive BOC Register**
 Register Address: **63H + (200h x n); where n = 0 to 7, for Ports 1 to 8**

Bit #	7	6	5	4	3	2	1	0
Name	-	-	RBOC5	RBOC4	RBOC3	RBOC2	RBOC1	RBOC0
Default	0	0	0	0	0	0	0	0

- Bit 5: BOC Bit 5 (RBOC5).**
- Bit 4: BOC Bit 4 (RBOC4).**
- Bit 3: BOC Bit 3 (RBOC3).**
- Bit 2: BOC Bit 2 (RBOC2).**
- Bit 1: BOC Bit 1 (RBOC1).**
- Bit 0: BOC Bit 0 (RBOC0).**

The RBOC Register always contains the last valid BOC received.

The Receive FDL Register (RFDL) reports the incoming Facility Data Link (FDL) or the incoming Fs bits. The LSB is received first. In D4 framing mode, RFDL updates on multiframe boundaries and reports the six Fs bits in RFDL0-RFDL5.

Register Name: **T1RSLC1, T1RSLC2, T1RSLC3**
 Register Description: **Receive SLC96 Data Link Registers – T1 MODE.**
 Register Address: **064H, 065H, 066H + (200h x n); where n = 0 to 7, for Ports 1 to 8**

(MSB)							(LSB)	
C8	C7	C6	C5	C4	C3	C2	C1	T1RSLC1
M2	M1	S=0	S=1	S=0	C11	C10	C9	T1RSLC2
S=1	S4	S3	S2	S1	A2	A1	M3	T1RSLC3

Note: These registers have an alternate definition for E1 mode. See [E1RAF](#), [E1RNAF](#), and [E1RsiAF](#).

Register Name: **E1RAF**
 Register Description: **E1 Receive Align Frame Register – E1 MODE**
 Register Address: **064H + (200h x n); where n = 0 to 7, for Ports 1 to 8**

Bit #	7	6	5	4	3	2	1	0
Name	Si	0	0	1	1	0	1	1
Default	0	0	0	0	0	0	0	0

Note: This register has an alternate definition for T1 mode. See [T1RSLC1](#).

- Bit 7 : International Bit (Si).**
- Bit 6 : Frame Alignment Signal Bit (0).**
- Bit 5 : Frame Alignment Signal Bit (0).**
- Bit 4 : Frame Alignment Signal Bit (1).**
- Bit 3 : Frame Alignment Signal Bit (1).**
- Bit 2 : Frame Alignment Signal Bit (0).**
- Bit 1 : Frame Alignment Signal Bit (1).**
- Bit 0 : Frame Alignment Signal Bit (1).**

Register Name: **E1RNAF**
 Register Description: **E1 Receive Non-Align Frame Register – E1 MODE**
 Register Address: **065H + (200h x n): where n = 0 to 7, for Ports 1 to 8**

Bit #	7	6	5	4	3	2	1	0
Name	Si	1	A	Sa4	Sa5	Sa6	Sa7	Sa8
Default	0	0	0	0	0	0	0	0

Note: This register has an alternate definition for T1 mode. See [T1RSLC2](#).

Bit 7 : International Bit (Si).

Bit 6 : Frame Non-Alignment Signal Bit (1).

Bit 5 : Remote Alarm (A).

Bit 4 : Additional Bit 4 (Sa4).

Bit 3 : Additional Bit 5 (Sa5).

Bit 2 : Additional Bit 6 (Sa6).

Bit 1 : Additional Bit 7 (Sa7).

Bit 0 : Additional Bit 8 (Sa8).

Register Name: **E1RsiAF**
 Register Description: **Received Si bits of the Align Frame – E1 MODE**
 Register Address: **066H + (200h x n): where n = 0 to 7, for Ports 1 to 8**

Bit #	7	6	5	4	3	2	1	0
Name	SiF14	SiF12	SiF10	SiF8	SiF6	SiF4	SiF2	SiF0
Default	0	0	0	0	0	0	0	0

Note: This register has an alternate definition for T1 mode. See [T1RSLC3](#).

Bit 7 : Si Bit of Frame 14 (SiF14).

Bit 6 : Si Bit of Frame 12 (SiF12).

Bit 5 : Si Bit of Frame 10 (SiF10).

Bit 4 : Si Bit of Frame 8 (SiF8).

Bit 3 : Si Bit of Frame 6 (SiF6).

Bit 2 : Si Bit of Frame 4 (SiF4).

Bit 1 : Si Bit of Frame 2 (SiF2).

Bit 0 : Si Bit of Frame 0 (SiF0).

Register Name: **E1RSiNAF**
 Register Description: **Received Si Bits of the Non-Align Frame**
 Register Address: **067H + (200h x n): where n = 0 to 7, for Ports 1 to 8**

Bit #	7	6	5	4	3	2	1	0
Name	SiF15	SiF13	SiF11	SiF9	SiF7	SiF5	SiF3	SiF1
Default	0	0	0	0	0	0	0	0

Bit 7 : Si Bit of Frame 15 (SiF15).

Bit 6 : Si Bit of Frame 13 (SiF13).

Bit 5 : Si Bit of Frame 11 (SiF11).

Bit 4 : Si Bit of Frame 9 (SiF9).

Bit 3 : Si Bit of Frame 7 (SiF7).

Bit 2 : Si Bit of Frame 5 (SiF5).

Bit 1 : Si Bit of Frame 3 (SiF3).

Bit 0 : Si Bit of Frame 1 (SiF1).

Register Name: **E1RRA**
 Register Description: **Received Remote Alarm**
 Register Address: **068H + (200h x n): where n = 0 to 7, for Ports 1 to 8**

Bit #	7	6	5	4	3	2	1	0
Name	RRAF15	RRAF13	RRAF11	RRAF9	RRAF7	RRAF5	RRAF3	RRAF1
Default	0	0	0	0	0	0	0	0

Bit 7 : Remote Alarm Bit of Frame 15 (RRAF15).

Bit 6 : Remote Alarm Bit of Frame 13 (RRAF13).

Bit 5 : Remote Alarm Bit of Frame 11 (RRAF11).

Bit 4 : Remote Alarm Bit of Frame 9 (RRAF9).

Bit 3 : Remote Alarm Bit of Frame 7 (RRAF7).

Bit 2 : Remote Alarm Bit of Frame 5 (RRAF5).

Bit 1 : Remote Alarm Bit of Frame 3 (RRAF3).

Bit 0 : Remote Alarm Bit of Frame 1 (RRAF1).

Register Name: **E1RSa4**
 Register Description: **Received Sa4 Bits**
 Register Address: **069H + (200h x n): where n = 0 to 7, for Ports 1 to 8**

Bit #	7	6	5	4	3	2	1	0
Name	RSa4F15	RSa4F13	RSa4F11	RSa4F9	RSa4F7	RSa4F5	RSa4F3	RSa4F1
Default	0	0	0	0	0	0	0	0

Bit 7 : Sa4 Bit of Frame 15 (RSa4F15).

Bit 6 : Sa4 Bit of Frame 13 (RSa4F13).

Bit 5 : Sa4 Bit of Frame 11 (RSa4F11).

Bit 4 : Sa4 Bit of Frame 9 (RSa4F9).

Bit 3 : Sa4 Bit of Frame 7 (RSa4F7).

Bit 2 : Sa4 Bit of Frame 5 (RSa4F5).

Bit 1 : Sa4 Bit of Frame 3 (RSa4F3).

Bit 0 : Sa4 Bit of Frame 1 (RSa4F1).

Register Name: **E1RSa5**
 Register Description: **Received Sa5 Bits**
 Register Address: **06AH + (200h x n): where n = 0 to 7, for Ports 1 to 8**

Bit #	7	6	5	4	3	2	1	0
Name	RSa5F15	RSa5F13	RSa5F11	RSa5F9	RSa5F7	RSa5F5	RSa5F3	RSa5F1
Default	0	0	0	0	0	0	0	0

Bit 7 : Sa5 Bit of Frame 15 (RSa5F15).

Bit 6 : Sa5 Bit of Frame 13 (RSa5F13).

Bit 5 : Sa5 Bit of Frame 11 (RSa5F11).

Bit 4 : Sa5 Bit of Frame 9 (RSa5F9).

Bit 3 : Sa5 Bit of Frame 7 (RSa5F7).

Bit 2 : Sa5 Bit of Frame 5 (RSa5F5).

Bit 1 : Sa5 Bit of Frame 3 (RSa5F3).

Bit 0 : Sa5 Bit of Frame 1 (RSa5F1).

Register Name: **E1RSa6**
 Register Description: **Received Sa6 Bits**
 Register Address: **06BH + (200h x n): where n = 0 to 7, for Ports 1 to 8**

Bit #	7	6	5	4	3	2	1	0
Name	RSa6F15	RSa6F13	RSa6F11	RSa6F9	RSa6F7	RSa6F5	RSa6F3	RSa6F1
Default	0	0	0	0	0	0	0	0

Bit 7 : Sa6 Bit of Frame 15 (RSa6F15).

Bit 6 : Sa6 Bit of Frame 13 (RSa6F13).

Bit 5 : Sa6 Bit of Frame 11 (RSa6F11).

Bit 4 : Sa6 Bit of Frame 9 (RSa6F9).

Bit 3 : Sa6 Bit of Frame 7 (RSa6F7).

Bit 2 : Sa6 Bit of Frame 5 (RSa6F5).

Bit 1 : Sa6 Bit of Frame 3 (RSa6F3).

Bit 0 : Sa6 Bit of Frame 1 (RSa6F1).

Register Name: **E1RSa7**
 Register Description: **Received Sa7 Bits**
 Register Address: **06CH + (200h x n): where n = 0 to 7, for Ports 1 to 8**

Bit #	7	6	5	4	3	2	1	0
Name	RSa7F15	RSa7F13	RSa7F11	RSa7F9	RSa7F7	RSa7F5	RSa7F3	RSa7F1
Default	0	0	0	0	0	0	0	0

Bit 7 : Sa7 Bit of Frame 15 (RSa7F15).

Bit 6 : Sa7 Bit of Frame 13 (RSa7F13).

Bit 5 : Sa7 Bit of Frame 11 (RSa7F11).

Bit 4 : Sa7 Bit of Frame 9 (RSa7F9).

Bit 3 : Sa7 Bit of Frame 7 (RSa7F7).

Bit 2 : Sa7 Bit of Frame 5 (RSa7F5).

Bit 1 : Sa7 Bit of Frame 3 (RSa7F3).

Bit 0 : Sa7 Bit of Frame 1 (RSa7F1).

Register Name: **E1RSa8**
 Register Description: **Received Sa8 Bits**
 Register Address: **06DH + (200h x n): where n = 0 to 7, for Ports 1 to 8**

Bit #	7	6	5	4	3	2	1	0
Name	RSa8F15	RSa8F13	RSa8F11	RSa8F9	RSa8F7	RSa8F5	RSa8F3	RSa8F1
Default	0	0	0	0	0	0	0	0

Bit 7 : Sa8 Bit of Frame 15 (RSa8F15).

Bit 6 : Sa8 Bit of Frame 13 (RSa8F13).

Bit 5 : Sa8 Bit of Frame 11 (RSa8F11).

Bit 4 : Sa8 Bit of Frame 9 (RSa8F9).

Bit 3 : Sa8 Bit of Frame 7 (RSa8F7).

Bit 2 : Sa8 Bit of Frame 5 (RSa8F5).

Bit 1 : Sa8 Bit of Frame 3 (RSa8F3).

Bit 0 : Sa8 Bit of Frame 1 (RSa8F1).

Register Name: **RMMR**
 Register Description: **Receive Master Mode Register**
 Register Address: **080H + (200h x n): where n = 0 to 7, for Ports 1 to 8**

Bit #	7	6	5	4	3	2	1	0
Name	FRM_EN	INIT_DONE	-	-	-	-	SFTRST	T1/E1
Default	0	0	0	0	0	0	0	0

Bit 7: Framer Enable (FRM_EN). This bit must be set to the desired state before writing INIT_DONE.
 0 = Framer disabled – held in low-power state
 1 = Framer enabled – all features active

Bit 6: Initialization Done (INIT_DONE). The user must set this bit once he has written the configuration registers. The host is required to write or clear all device registers prior to setting this bit. Once INIT_DONE is set, the DS26528 will check the FRM_EN bit and, if enabled will begin operation based on the initial configuration.

Bit 1 : Soft Reset (SFTRST). Level sensitive ‘soft’ reset. Should be taken high then low to reset the receiver.
 0 = Normal operation
 1 = Reset the receiver.

Bit 0 : Receiver T1/E1 Mode Select (T1/E1). Sets operating mode for receiver only! This bit must be set to the desired state before writing INIT_DONE.
 0 = T1 operation
 1 = E1 operation

Register Name: **RCR1**
 Register Description: **Receive Control Register 1 – T1 MODE**
 Register Address: **081H + (200h x n); where n = 0 to 7, for Ports 1 to 8**

Bit #	7	6	5	4	3	2	1	0
Name	SYNCT	RB8ZS	RFM	ARC	SYNCC	RJC	SYNCE	RESYNC
Default	0	0	0	0	0	0	0	0

Note: This register has an alternate definition for E1 mode. See [RCR1](#).

Bit 7 : Sync Time (SYNCT).

- 0 = qualify 10 bits
- 1 = qualify 24 bits

Bit 6 : Receive B8ZS Enable (RB8ZS).

- 0 = B8ZS disabled
- 1 = B8ZS enabled

Bit 5 : Receive Frame Mode Select (RFM).

- 0 = ESF framing mode
- 1 = D4 framing mode

Bit 4 : Auto Resync Criteria (ARC).

- 0 = Resync on OOF or LOS event
- 1 = Resync on OOF only

Bit 3 : Sync Criteria (SYNCC).

In D4 Framing Mode.

- 0 = search for Ft pattern, then search for Fs pattern
- 1 = cross couple Ft and Fs pattern

In ESF Framing Mode.

- 0 = search for FPS pattern only
- 1 = search for FPS and verify with CRC6

Bit 2 : Receive Japanese CRC6 Enable (RJC).

- 0 = use ANSI:AT&T:ITU CRC6 calculation (normal operation)
- 1 = use Japanese standard JT-G704 CRC6 calculation

Bit 1 : Sync Enable (SYNCE).

- 0 = auto resync enabled
- 1 = auto resync disabled

Bit 0 : Resynchronize (RESYNC). When toggled from low to high, a resynchronization of the receive side framer is initiated. Must be cleared and set again for a subsequent resync.

Register Name: **RCR1**
 Register Description: **Receive Control Register 1 – E1 MODE**
 Register Address: **081H + (200h x n); where n = 0 to 7, for Ports 1 to 8**

Bit #	7	6	5	4	3	2	1	0
Name	-	RHDB3	RSIGM	RG802	RCRC4	FRC	SYNCE	RESYNC
Default	0	0	0	0	0	0	0	0

Note: This register has an alternate definition for T1 mode. See [RCR1](#).

Bit 6 : Receive HDB3 Enable (RHDB3).

- 0 = HDB3 disabled
- 1 = HDB3 enabled (decoded per O.162)

Bit 5 : Receive Signaling Mode Select (RSIGM).

- 0 = CAS signaling mode
- 1 = CCS signaling mode

Bit 4 : Receive G.802 Enable (RG802). See Section 19 for details.

- 0 = do not force RCHBLK high during bit 1 of time slot 26
- 1 = force RCHBLK high during bit 1 of time slot 26

Bit 3 : Receive CRC4 Enable (RCRC4).

- 0 = CRC4 disabled
- 1 = CRC4 enabled

Bit 2 : Frame Resync Criteria (FRC).

- 0 = resync if FAS received in error 3 consecutive times
- 1 = resync if FAS or bit 2 of non-FAS is received in error 3 consecutive times

Bit 1 : Sync Enable (SYNCE).

- 0 = auto resync enabled
- 1 = auto resync disabled

Bit 0 : Resynchronize (RESYNC). When toggled from low to high, a resynchronization of the receive side framer is initiated. Must be cleared and set again for a subsequent resync.

Register Name: **T1RIBCC**
 Register Description: **Receive In-Band Code Control Register – T1 MODE**
 Register Address: **082H + (200h x n): where n = 0 to 7, for Ports 1 to 8**

Bit #	7	6	5	4	3	2	1	0
Name	--	--	RUP2	RUP1	RUP0	RDN2	RDN1	RDN0
Default	0	0	0	0	0	0	0	0

Note: This register has an alternate definition for E1 mode. See [E1RCR2](#).

Bits 5 to 3 : Receive Up Code Length Definition Bits (RUP2 to RUP0).

RUP2	RUP1	RUP0	LENGTH SELECTED
0	0	0	1 bits
0	0	1	2 bits
0	1	0	3 bits
0	1	1	4 bits
1	0	0	5 bits
1	0	1	6 bits
1	1	0	7 bits
1	1	1	8 : 16 bits

Bits 2 to 0 : Receive Down Code Length Definition Bits (RDN2 to RDN0).

RDN2	RDN1	RDN0	LENGTH SELECTED
0	0	0	1 bits
0	0	1	2 bits
0	1	0	3 bits
0	1	1	4 bits
1	0	0	5 bits
1	0	1	6 bits
1	1	0	7 bits
1	1	1	8 : 16 bits

Register Name: **E1RCR2**
 Register Description: **Receive Control Register 2 – E1 MODE**
 Register Address: **082H+ (200h x n): where n = 0 to 7, for Ports 1 to 8**

Bit #	7	6	5	4	3	2	1	0
Name	RSa8S	RSa7S	RSa6S	RSa5S	RSa4S	-	-	RLOSA
Default	0	0	0	0	0	0	0	0

Note: This register has an alternate definition for T1 mode. See [T1RIBCC](#).

Bit 7 : Sa8 Bit Select (Sa8S). Set to one to have RLCLK pulse at the Sa8 bit position; set to zero to force RLCLK low during Sa8 bit position.

Bit 6 : Sa7 Bit Select (Sa7S). Set to one to have RLCLK pulse at the Sa7 bit position; set to zero to force RLCLK low during Sa7 bit position.

Bit 5 : Sa6 Bit Select (Sa6S). Set to one to have RLCLK pulse at the Sa6 bit position; set to zero to force RLCLK low during Sa6 bit position.

Bit 4 : Sa5 Bit Select (Sa5S). Set to one to have RLCLK pulse at the Sa5 bit position; set to zero to force RLCLK low during Sa5 bit position.

Bit 3 : Sa4 Bit Select (Sa4S). Set to one to have RLCLK pulse at the Sa4 bit position; set to zero to force RLCLK low during Sa4 bit position.

Bit 0 : Receive Loss of Signal Alternate Criteria (RLOSA). Defines the criteria for a Loss of Signal condition.

0 = LOS declared upon 255 consecutive zeros (125 μ s)

1 = LOS declared upon 2048 consecutive zeros (1ms)

Register Name: **RCR3**
 Register Description: **Receive Control Register 3**
 Register Address: **083H + (200h x n): where n = 0 to 7, for Ports 1 to 8**

Bit #	7	6	5	4	3	2	1	0
Name	IDF	-	RSERC	-	-	-	PLB	FLB
Default	0	0	0	0	0	0	0	0

Bit 7 : Input Data Format (IDF).

0 = Bipolar data is expected at RPOS and RNEG (either AMI or B8ZS)

1 = NRZ data is expected at RPOS. The BPV counter will be disabled and RNEG will be ignored by the DS26528.

Bit 5 : RSER Control (RSERC).

0 = allow RSER to output data as received under all conditions (normal operation)

1 = force RSER to one under loss of frame alignment conditions

Bit 1 : Payload Loopback (PLB).

0 = loopback disabled

1 = loopback enabled

When PLB is enabled, the following will occur:

1. data will be transmitted from the TPOS and TNEG pins synchronous with RCLK instead of TCLK
2. all of the receive side signals will continue to operate normally
3. the TCHCLK and TCHBLK signals are forced low
4. data at the TSER, TDATA, and TSIG pins is ignored
5. the TLCLK signal will become synchronous with RCLK instead of TCLK.

In a PLB situation, the DS26528 will loop the 192 bits (248 for E1) of pay-load data (with BPVs corrected) from the receive section back to the transmit section. The transmitter will follow the frame alignment provided by the receiver. The receive frame boundary is automatically fed into the transmit section, such that the transmit frame position is locked to the receiver (i.e., TSYNC is sourced from RSYNC). The FPS framing pattern, CRC6 calculation, and the FDL bits (FAS word, Si, Sa, E-bits, and CRC4 for E1) are not looped back, they are reinserted by the DS26528 (i.e., the transmit section will modify the payload as if it was input at TSER).

Bit 0 : Framer Loopback (FLB).

0 = loopback disabled

1 = loopback enabled

This loopback is useful in testing and debugging applications. In FLB, the DS26528 will loop data from the transmit side back to the receive side. When FLB is enabled, the following will occur:

1. (T1 mode) an unframed all-ones code will be transmitted at TPOS and TNEG
(E1 mode) normal data will be transmitted at TPOS and TNEG
2. Data at RPOS and RNEG will be ignored
3. All receive side signals will take on timing synchronous with TCLK instead of RCLK.
Note that it is not acceptable to have RCLK tied to TCLK during this loopback because this will cause an unstable condition.

Register Name: **RIOCR**
 Register Description: **Receive I/O Configuration Register**
 Register Address: **084H + (200h x n): where n = 0 to 7, for Ports 1 to 8**

Bit #	7	6	5	4	3	2	1	0
Name	RCLKINV	RSYNCINV	H100EN	RSCLKM	RSMS	RSIO	RSMS2	RSMS1
Default	0	0	0	0	0	0	0	0

Bit 7 : RCLK Invert (RCLKINV).

0 = No inversion
 1 = Invert RCLK as input

Bit 6 : RSYNC Invert (RSYNCINV).

0 = No inversion
 1 = Invert RSYNC as either input or output

Bit 5 : H.100 SYNC Mode (H100EN). See Section [9.8.3](#) for more information.

0 = Normal operation
 1 = RSYNC and TSSYNCIO signals are shifted

Bit 4 : RSYCLK Mode Select (RSCLKM).

0 = if RSYCLK is 1.544MHz
 1 = if RSYCLK is 2.048MHz or IBO enabled

Bit 3 : RSYNC Multiframe Skip Control (RSMS). T1 Mode ONLY. Useful in framing format conversions from D4 to ESF. This function is not available when the receive side elastic store is enabled. RSYNC must be set to output multiframe pulses.

0 = RSYNC will output a pulse at every multiframe
 1 = RSYNC will output a pulse at every other multiframe

Bit 2 : RSYNC I/O Select (RSIO). (Note: this bit must be set to zero when elastic store is disabled)

0 = RSYNC is an output
 1 = RSYNC is an input (only valid if elastic store enabled)

Bit 1 : RSYNC Mode Select 2 (RSMS2).

T1: RSYNC pin must be programmed in the output frame mode

0 = do not pulse double wide in signaling frames
 1 = do pulse double wide in signaling frames

E1: RSYNC pin must be programmed in the output multiframe mode

0 = RSYNC outputs CAS multiframe boundaries
 1 = RSYNC outputs CRC4 multiframe boundaries

In E1 mode, RSMS2 also selects which multiframe signal is available at the RMSYNC pin, regardless of the configuration for RSYNC. When RSMS2 = 0, RMSYNC outputs CAS multiframe boundaries; when RSMS2 = 1, RMSYNC outputs CRC4 multiframe boundaries.

Bit 0 : RSYNC Mode Select 1 (RSMS1). Selects frame or multiframe pulse when RSYNC pin is in output mode. In input mode (elastic store must be enabled) multiframe mode is only useful when receive signaling reinsertion is enabled.

0 = frame mode
 1 = multiframe mode

Register Name: **RESCR**
 Register Description: **Receive Elastic Store Control Register**
 Register Address: **085H + (200h x n): where n = 0 to 7, for Ports 1 to 8**

Bit #	7	6	5	4	3	2	1	0
Name	RDATFMT	RGCLKEN	-	RSZS	RESALGN	RESR	RESMDM	RESE
Default	0	0	0	0	0	0	0	0

Bit 7 : Receive Channel Data Format (RDATFMT).

- 0 = 64KBps (data contained in all 8 bits)
- 1 = 56KBps (data contained in 7 out of the 8 bits)

Bit 6 : Receive Gapped Clock Enable (RGCLKEN).

- 0 = RCHCLK functions normally
- 1 = Enable gapped bit clock output on RCHCLK

RGCLKEN and RDATFMT are not associated with the elastic store and will be explained in the fractional support section.

Bit 4 : Receive Slip Zone Select (RSZS). This bit determines the minimum distance allowed between the elastic store read and write pointers before forcing a controlled slip. This bit is only applies during T1 to E1 or E1 to T1 conversion applications.

- 0 = force a slip at 9 bytes or less of separation (used for clustered blank channels)
- 1 = force a slip at 2 bytes or less of separation (used for distributed blank channels and minimum delay mode)

Bit 3 : Receive Elastic Store Align (RESALGN). Setting this bit from a zero to a one will force the receive elastic store's write/read pointers to a minimum separation of half a frame. No action will be taken if the pointer separation is already greater or equal to half a frame. If pointer separation is less than half a frame, the command will be executed and the data will be disrupted. Should be toggled after RSYCLK has been applied and is stable. Must be cleared and set again for a subsequent align.

Bit 2 : Receive Elastic Store Reset (RESR). Setting this bit from a zero to a one will force the read pointer into the same frame that the write pointer is exiting, minimizing the delay through the elastic store. If this command should place the pointers within the slip zone (see bit 4), then an immediate slip will occur and the pointers will move back to opposite frames. Should be toggled after RSYCLK has been applied and is stable. Do not leave this bit set HIGH.

Bit 1 : Receive Elastic Store Minimum Delay Mode (RESMDM).

- 0 = elastic stores operate at full two frame depth
- 1 = elastic stores operate at 32-bit depth

Bit 0 : Receive Elastic Store Enable (RESE).

- 0 = elastic store is bypassed
- 1 = elastic store is enabled

Register Name: **ERCNT**
 Register Description: **Error Counter Configuration Register**
 Register Address: **086H + (200h x n); where n = 0 to 7, for Ports 1 to 8**

Bit #	7	6	5	4	3	2	1	0
Name	1SECS	MCUS	MECU	ECUS	EAMS	FSBE	MOSCR F	LCVCRF
Default	0	0	0	0	0	0	0	0

Bit 7 / One-Second Select (1SECS). This bit allows for synchronization of the error counter updates between multiple ports. When ERCNT.3=0, setting this bit (on a specific framer) will update the framer's error counters on the transition of the one-second timer from framer #1. Note that this bit should always be clear for framer #1.

0 = Use the one-second timer that is internal to the framer.

1 = Use the one-second timer from framer #1 to latch updates.

Bit 6 : Manual Counter Update Select (MCUS). When manual update mode is enabled with EAMS, this bit can be used to allow the incoming LATCH_CNT signal to latch all counters. Useful for synchronously latching counters of multiple DS26528 cores located on the same die.

0 = MECU is used to manually latch counters.

1 = Counters are latched on the rising edge of the LATCH_CNT signal.

Bit 5 : Manual Error Counter Update (MECU). When enabled by ERCNT.3, the changing of this bit from a 0 to a 1 allows the next clock cycle to load the error counter registers with the latest counts and reset the counters. The user must wait a minimum of 250µs before reading the error count registers to allow for proper update.

Bit 4 : Error Counter Update Select (ECUS).

T1 mode:

0 = Update error counters once a second

1 = Update error counters every 42ms (333 frames)

E1 mode:

0 = Update error counters once a second

1 = Update error counters every 62.5ms (500 frames)

Bit 3 : Error Accumulation Mode Select (EAMS).

0 = Automatic updating of error counters enabled. The state of ERCNT.4 determines accumulation time (timed update)

1 = User toggling of ERCNT.5 determines accumulation time (manual update)

Bit 2 : PCVCR Fs-Bit Error Report Enable (FSBE). T1 Mode Only.

0 = do not report bit errors in Fs-bit position; only Ft-bit position

1 = report bit errors in Fs-bit position as well as Ft-bit position

Bit 1 : Multiframe Out of Sync Count Register Function Select (MOSCRF). T1 Mode Only.

0 = count errors in the framing bit position

1 = count the number of multiframes out of sync

Bit 0 : T1 Line Code Violation Count Register Function Select (LCVCRF).

0 = do not count excessive zeros

1 = count excessive zeros

Register Name: **RHFC**
 Register Description: **Receive HDLC FIFO Control Register**
 Register Address: **087H + (200h x n); where n = 0 to 7, for Ports 1 to 8**

Bit #	7	6	5	4	3	2	1	0
Name	-	-	-	-	-	-	RFHWM1	RFHWM0
Default	0	0	0	0	0	0	0	0

Bits 1 to 0 : Receive FIFO High Watermark Select (RFHWM1 to RFHWM0).

RFHWM1	RFHWM0	Receive FIFO Watermark
0	0	4 bytes
0	1	16 bytes
1	0	32 bytes
1	1	48 bytes

Register Name: **RIBOC**
 Register Description: **Receive Interleave Bus Operation Control Register**
 Register Address: **088H + (200h x n); where n = 0 to 7, for Ports 1 to 8**

Bit #	7	6	5	4	3	2	1	0
Name	-	IBS1	IBS0	IBOSEL	IBOEN	DA2	DA1	DA0
Default	0	0	0	0	0	0	0	0

Bits 6 to 5 : IBO Bus Size bit 1 (IBS1 to IBS0). Indicates how many devices on the bus.

IBS1	IBS0	Bus Size
0	0	2 Devices on bus (4.096MHz)
0	1	4 Devices on bus (8.192MHz)
1	0	8 Devices on bus (16.384MHz)
1	1	Reserved for future use

Bit 4 : Interleave Bus Operation Select (IBOSEL). This bit selects channel or frame interleave mode.
 0 = Channel Interleave
 1 = Frame Interleave

Bit 3 : Interleave Bus Operation Enable (IBOEN).
 0 = Interleave Bus Operation disabled.
 1 = Interleave Bus Operation enabled.

Bits 2 to 0 : Device Assignment bits (DA2 to DA0).

DA2	DA1	DA0	Device Position
0	0	0	1st Device on bus
0	0	1	2nd Device on bus
0	1	0	3rd Device on bus
0	1	1	4th Device on bus
1	0	0	5th Device on bus
1	0	1	6th Device on bus
1	1	0	7th Device on bus
1	1	1	8th Device on bus

Register Name: **T1RSCC**
 Register Description: **In-Band Receive Spare Control Register**
 Register Address: **089H + (200h x n): where n = 0 to 7, for Ports 1 to 8**

Bit #	7	6	5	4	3	2	1	0
Name	-	-	-	-	-	RSC2	RSC1	RSC0
Default	0	0	0	0	0	0	0	0

Bits 7 to 3 : Reserved, must be set to zero for proper operation

Bits 2 to 0 : Receive Spare Code Length Definition Bits (RSC2 to RSC0).

RSC2	RSC1	RSC0	LENGTH SELECTED
0	0	0	1 bits
0	0	1	2 bits
0	1	0	3 bits
0	1	1	4 bits
1	0	0	5 bits
1	0	1	6 bits
1	1	0	7 bits
1	1	1	8 : 16 bits

Register Name: **RXPC**
 Register Description: **Receive eXpansion Port Control Register**
 Register Address: **08AH + (200h x n): where n = 0 to 7, for Ports 1 to 8**

Bit #	7	6	5	4	3	2	1	0
Name	--	--	--	--	--	RBPDIR	RBPFUS	RBPEN
Default	0	0	0	0	0	0	0	0

Bit 2 : Receive BERT Port Direction Control (RBPDIR).

0 = Normal (line) operation. Rx BERT port sources data from the receive path (RNRZ Data).

1 = System (Backplane) operation. Rx BERT port sources data from the transmit path. In this mode the data on RBPDATA becomes TDATA (transmit data on the line side of the e-store). The clock on RBPCLK becomes the clock that was generated for TBPCLK (must be referenced to TCLK).

Bit 1 : Receive BERT Port Framed/Unframed Select (RBPFUS). T1 Mode Only.

0 = The DS26528's RBP_CLK will not clock data from the F-bit position (framed)

1 = The DS26528's RBP_CLK will clock data from the F-bit position (unframed)

Bit 0 : Receive BERT Port Enable (RBPEN).

0 = Receive BERT Port is not active

1 = Receive BERT Port is active.

Register Name: **RBPBS**
 Register Description: **Receive BERT Port Bit Suppress Register**
 Register Address: **08BH + (200h x n): where n = 0 to 7, for Ports 1 to 8**

Bit #	7	6	5	4	3	2	1	0
Name	BPBSE8	BPBSE7	BPBSE6	BPBSE5	BPBSE4	BPBSE3	BPBSE2	BPBSE1
Default	0	0	0	0	0	0	0	0

Bit 7 : Receive Channel Bit 8 Suppress (BPBSE8). MSB of the channel. Set to one to stop this bit from being used.

Bit 6 : Receive Channel Bit 7 Suppress (BPBSE7). Set to one to stop this bit from being used.

Bit 5 : Receive Channel Bit 6 Suppress (BPBSE6). Set to one to stop this bit from being used.

Bit 4 : Receive Channel Bit 5 Suppress (BPBSE5). Set to one to stop this bit from being used.

Bit 3 : Receive Channel Bit 4 Suppress (BPBSE4). Set to one to stop this bit from being used.

Bit 2 : Receive Channel Bit 3 Suppress (BPBSE3). Set to one to stop this bit from being used.

Bit 1 : Receive Channel Bit 2 Suppress (BPBSE2). Set to one to stop this bit from being used.

Bit 0 : Receive Channel Bit 1 Suppress (BPBSE1). LSB of the channel. Set to one to stop this bit from being used.

Register Name: **RLS1**
 Register Description: **Receive Latched Status Register 1**
 Register Address: **090H + (200h x n): where n = 0 to 7, for Ports 1 to 8**

Bit #	7	6	5	4	3	2	1	0
Name	RRAIC	RAISC	RLOSC	RLOFC	RRAID	RAISD	RLOSD	RLOFD
Default	0	0	0	0	0	0	0	0

All bits in this register are latched and can create interrupts.

Bit 7 : Receive Remote Alarm Indication Condition Clear (RRAIC). Falling edge detect of RRAI. Set when a RRAI condition has cleared.

Bit 6 : Receive Alarm Indication Signal Condition Clear (RAISC). Falling edge detect of RAIS. Set when a RAIS condition has cleared.

Bit 5 : Receive Loss of Signal Condition Clear (RLOSC). Falling edge detect of RLOS. Set when an RLOS condition has cleared.

Bit 4 : Receive Loss of Frame Condition Clear (RLOFC). Falling edge detect of RLOF. Set when an RLOF condition has cleared.

Bit 3 : Receive Remote Alarm Indication Condition Detect (RRAID). Rising edge detect of RRAI. Set when a remote alarm is received at RPOS and RNEG.

Bit 2 : Receive Alarm Indication Signal Condition Detect (RAISD). Rising edge detect of RAIS. Set when an unframed all one's code is received at RPOS and RNEG.

Bit 1 : Receive Loss of Signal Condition Detect (RLOSD). Rising edge detect of RLOS. Set when 192 consecutive zeros have been detected at RPOS and RNEG.

Bit 0 : Receive Loss of Frame Condition Detect (RLOFD). Rising edge detect of RLOF. Set when the DS26528 has lost synchronized to the received data stream.

Register Name: **RLS2 – T1 Mode**
 Register Description: **Receive Latched Status Register 2**
 Register Address: **091H + (200h x n); where n = 0 to 7, for Ports 1 to 8**

Bit #	7	6	5	4	3	2	1	0
Name	RPDV	-	COFA	8ZD	16ZD	SEFE	B8ZS	FBE
Default	0	0	0	0	0	0	0	0

All bits in these register are latched. This register does not create interrupts.

Bit 7 : Receive Pulse Density Violation Event (RPDV). Set when the receive data stream does not meet the ANSI T1.403 requirements for pulse density.

Bit 5 : Change of Frame Alignment Event (COFA). Set when the last resync resulted in a change of frame or multiframe alignment.

Bit 4 : Eight Zero Detect Event (8ZD). Set when a string of at least eight consecutive zeros (regardless of the length of the string) have been received at RPOS and RNEG.

Bit 3 : Sixteen Zero Detect Event (16ZD). Set when a string of at least sixteen consecutive zeros (regardless of the length of the string) have been received at RPOS and RNEG.

Bit 2 : Severely Errored Framing Event (SEFE). Set when 2 out of 6 framing bits (Ft or FPS) are received in error.

Bit 1 : B8ZS Codeword Detect Event (B8ZS). Set when a B8ZS codeword is detected at RPOS and RNEG independent of whether the B8ZS mode is selected or not. Useful for automatically setting the line coding.

Bit 0 : Frame Bit Error Event (FBE). Set when a Ft (D4) or FPS (ESF) framing bit is received in error.

Register Name: **RLS2 – E1 Mode**
 Register Description: **E1 Receive Latched Status Register 2**
 Register Address: **091H + (200h x n); where n = 0 to 7, for Ports 1 to 8**

Bit #	7	6	5	4	3	2	1	0
Name	-	CRCRC	CASRC	FASRC	RSA1	RSA0	RCMF	RAF
Default	0	0	0	0	0	0	0	0

Note: All bits in this register are latched. Bits 0 – 3 can cause interrupts. There is no associated real-time register.

Bit 6 : CRC Resync Criteria Met Event (CRCRC). Set when 915:1000 codewords are received in error.

Bit 5 : CAS Resync Criteria Met Event (CASRC). Set when 2 consecutive CAS MF alignment words are received in error.

Bit 4 : FAS Resync Criteria Met Event (FASRC). Set when 3 consecutive FAS words are received in error.

Bit 3 : Receive Signaling All Ones Event (RSA1). Set when the contents of time slot 16 contains less than three zeros over 16 consecutive frames. This alarm is not disabled in the CCS signaling mode.

Bit 2 : Receive Signaling All Zeros Event (RSA0). Set when over a full MF, time slot 16 contains all zeros.

Bit 1 : Receive CRC4 Multiframe Event (RCMF). Set on CRC4 multiframe boundaries; will continue to be set every 2 ms on an arbitrary boundary if CRC4 is disabled.

Bit 0 : Receive Align Frame Event (RAF). Set approximately every 250µs to alert the host that Si and Sa bits are available in the RAF and RRAF registers.

Register Name: **RLS3 – T1 Mode**
 Register Description: **Receive Latched Status Register 3**
 Register Address: **092H + (200h x n); where n = 0 to 7, for Ports 1 to 8**

Bit #	7	6	5	4	3	2	1	0
Name	LORCC	LSPC	LDNC	LUPC	LORCD	LSPD	LDND	LUPD
Default	0	0	0	0	0	0	0	0

All bits in this register are latched and can create interrupts.

Bit 7 : Loss of Receive Clock Condition Clear (LORCC). Falling edge detect of LORC. Set when a LORC condition was detected and then removed.

Bit 6 : Spare Code Detected Condition Clear (LSPC). Falling edge detect of LSP. Set when a spare-code match condition was detected and then removed.

Bit 5 : Loop Down Code Detected Condition Clear (LDNC). Falling edge detect of LDN. Set when a loop-down condition was detected and then removed

Bit 4 : Loop Up Code Detected Condition Clear (LUPC). Falling edge detect of LUP. Set when a loop-up condition was detected and then removed.

Bit 3 : Loss of Receive Clock Condition Detect (LORCD). Rising edge detect of LORC. Set when the RCLK pin has not transitioned for one channel time.

Bit 2 : Spare Code Detected Condition Detect (LSPD). Rising edge detect of LSP. Set when the spare code as defined in the RSCD1:2 registers is being received.

Bit 1 : Loop Down Code Detected Condition Detect (LDND). Rising edge detect of LDN. Set when the loop down code as defined in the RDNC1:2 register is being received.

Bit 0 : Loop Up Code Detected Condition Detect (LUPD). Rising edge detect of LUP. Set when the loop up code as defined in the RUPC1:2 register is being received.

Register Name: **RLS3 – E1 Mode**
 Register Description: **Receive Latched Status Register 3**
 Register Address: **092H + (200h x n): where n = 0 to 7, for Ports 1 to 8**

Bit #	7	6	5	4	3	2	1	0
Name	LORCC	-	V52LNKC	RDMAC	LORCD	-	V52LNKD	RDMAD
Default	0	0	0	0	0	0	0	0

Note: All bits in this register are latched and can create interrupts.

Bit 7 : Loss of Receive Clock Clear (LORCC). Change of state indication. Set when a LORC condition has cleared (falling edge detect of LORC)

Bit 5 : V5.2 Link Detected Clear (V52LNKC). Change of state indication. Set when a V52LNK condition has cleared (falling edge detect of V52LNK).

Bit 4 : Receive Distant MF Alarm Clear (RDMAC). Change of state indication. Set when a RDMA condition has cleared (falling edge detect of RDMA).

Bit 3 : Loss of Receive Clock Detect (LORCD). Change of state indication. Set when the RCLK pin has not transitioned for one channel time (rising edge detect of LORC).

Bit 1 : V5.2 Link Detect (V52LNKD). Change of state indication. Set on detection of a V5.2 link identification signal. (G.965). This is the rising edge detect of V52LNK.

Bit 0 : Receive Distant MF Alarm Detect (RDMAD). Change of state indication. Set when bit-6 of time slot 16 in frame 0 has been set for two consecutive multiframes. This alarm is not disabled in the CCS signaling mode. This is the rising edge detect of RDMA.

Register Name: **RLS4**
 Register Description: **Receive Latched Status Register 4**
 Register Address: **093H + (200h x n): where n = 0 to 7, for Ports 1 to 8**

Bit #	7	6	5	4	3	2	1	0
Name	RESF	RESEM	RSLIP		RSCOS	1SEC	TIMER	RMF
Default	0	0	0	0	0	0	0	0

All bits in this register are latched and can create interrupts.

Bit 7 : Receive Elastic Store Full Event (RESF). Set when the receive elastic store buffer fills and a frame is deleted.

Bit 6 : Receive Elastic Store Empty Event (RESEM). Set when the receive elastic store buffer empties and a frame is repeated.

Bit 5 : Receive Elastic Store Slip Occurrence Event (RSLIP). Set when the receive elastic store has either repeated or deleted a frame.

Bit 3 : Receive Signaling Change Of State Event (RSCOS). Set when any channel selected by the Receive Signaling Change Of State Interrupt Enable registers ([RSCSE1](#) through RSCSE3), changes signaling state.

Bit 2 : One Second Timer (1SEC). Set on every 1 second interval based on RCLK.

Bit 1 : Timer Event (TIMER). This status bit indicates that the performance monitor counters have been updated and are available to be read by the host. The error counter update interval as determined by the settings in the Error Counter Configuration Register (ERCNT).

T1: Set on increments of 1 second or 42ms based on RCLK, or a manual latch event.

E1: Set on increments of 1 second or 62.5ms based on RCLK, or a manual latch event.

Bit 0 : Receive Multiframe Event (RMF). In T1 operation, set every 1.5ms on D4 MF boundaries or every 3ms on ESF MF boundaries.

In E1 operation, set every 2.0ms on receive CAS multiframe boundaries to alert host the signaling data is available. Continues to set on an arbitrary 2.0ms boundary when CAS signaling is not enabled.

Register Name: **RLS5**
 Register Description: **Receive Latched Status Register 5 (HDLC)**
 Register Address: **094H + (200h x n): where n = 0 to 7, for Ports 1 to 8**

Bit #	7	6	5	4	3	2	1	0
Name	-	-	ROVR	RHOBT	RPE	RPS	RHWMS	RNES
Default	0	0	0	0	0	0	0	0

All bits in this register are latched and can cause interrupts.

Bit 5 : Receive FIFO Overrun (ROVR). Set when the receive HDLC controller has terminated packet reception because the FIFO buffer is full.

Bit 4 : Receive HDLC Opening Byte Event (RHOBT). Set when the next byte available in the receive FIFO is the first byte of a message.

Bit 3 : Receive Packet End Event (RPE). Set when the HDLC controller detects either the finish of a valid message (i.e., CRC check complete) or when the controller has experienced a message fault such as a CRC checking error, or an overrun condition, or an abort has been seen. This is a latched bit and will be cleared when read.

Bit 2 : Receive Packet Start Event (RPS). Set when the HDLC controller detects an opening byte. This is a latched bit and will be cleared when read.

Bit 1 : Receive FIFO Above High Watermark Set Event (RHWMS). Set when the receive 64-byte FIFO crosses the high watermark as defined by the Receive HDLC FIFO Control Register (RHFC). Rising edge detect of RHWMS.

Bit 0 : Receive FIFO Not Empty Set Event (RNES). Set when the receive FIFO has transitioned from 'empty' to 'not-empty' (at least one byte has been put into the FIFO). Rising edge detect of RNE.

Register Name: **RLS7**
 Register Description: **Receive Latched Status Register 7**
 Register Address: **096H + (200h x n): where n = 0 to 7, for Ports 1 to 8**

Bit #	7	6	5	4	3	2	1	0
Name	-	-	RRAI-CI	RAIS-CI	RSLC96	RFDLF	BC	BD
Default	0	0	0	0	0	0	0	0

All bits in this register are latched and can create interrupts.

Bit 5 : Receive RAI-CI Detect (RRAI-CI). Set when an RAI-CI pattern has been detected by the receiver (see Section). This bit is active in ESF framing mode only, and will set only if an RAI condition is being detected ([RRTS1.3](#)). When the host reads (and clears) this bit, it will set again each time the RAI-CI pattern is detected (approximately every 1.1 seconds).

Bit 4 : Receive AIS-CI Detect (RAIS-CI). Set when an AIS-CI pattern has been detected by the receiver (see Section). This bit will set only if an AIS condition is being detected ([RRTS1.2](#)). This is a latched bit which must be cleared by the host, and will set again each time the AIS-CI pattern is detected (approximately every 1.2 seconds).

Bit 3 : Receive SLC-96 Alignment Event (RSLC96). Set when a valid SLC-96 alignment pattern is detected in the Fs bit stream, and the RSLCx registers have data available for retrieval. See Section [9.9.4.4](#) for more information.

Bit 2 : Receive FDL Register Full Event (RFDLF). Set when the 8-bit RFDL register is full. Useful for SLC-96 operation, or manual extraction of FDL data bits. See Section [9.9.5.4](#) for more information.

Bit 1 : BOC Clear Event (BC). Set when a valid BOC is no longer detected (with the Disintegration filter applied).

Bit 0 : BOC Detect Event (BD). Set when a valid BOC has been detected (with the BOC filter applied).

Register Name: **RSS1, RSS2, RSS3, RSS4**
 Register Description: **Receive Signaling Status Registers**
 Register Address: **098H, 099H, 09AH, 09BH + (200h x n): where n = 0 to 7, for Ports 1 to 8**

(MSB)							(LSB)	
CH8	CH7	CH6	CH5	CH4	CH3	CH2	CH1*	RSS1
CH16	CH15	CH14	CH13	CH12	CH11	CH10	CH9	RSS2
CH24	CH23	CH22	CH21	CH20	CH19	CH18	CH17*	RSS3
CH32	CH31	CH30	CH29	CH28	CH27	CH26	CH25	RSS4 (E1 mode)

Note: Status bits in this register are latched.

When a channel's signaling data changes state, the respective bit in registers RSS1-RSS4 will be set and latched. The RSCOS bit (RLSR4.3) will be set if the channel was also enabled by setting the appropriate bit in [RSCSE1-4](#). The INTB signal will go low if enabled by the interrupt mask bit RIM4.3. The bit will remain set until read. Note that in E1 CAS mode, the LSB of RSS1 would typically represent the CAS alignment bits, and the LSB of RSS3 represents reserved bits and the distant multiframe alarm.

Register Name: **T1RSCD1**
 Register Description: **Receive Spare Code Definition Register 1**
 Register Address: **09CH + (200h x n): where n = 0 to 7, for Ports 1 to 8**

Bit #	7	6	5	4	3	2	1	0
Name	C7	C6	C5	C4	C3	C2	C1	C0
Default	0	0	0	0	0	0	0	0

Note: Writing this register resets the detector's integration period.

Bit 7 : Receive Spare Code Definition Bit 7 (C7). First bit of the repeating pattern.

Bit 6 : Receive Spare Code Definition Bit 6 (C6). A Don't Care if a 1-bit length is selected.

Bit 5 : Receive Spare Code Definition Bit 5 (C5). A Don't Care if a 1 or 2 bit length is selected.

Bit 4 : Receive Spare Code Definition Bit 4 (C4). A Don't Care if a 1 to 3 bit length is selected.

Bit 3 : Receive Spare Code Definition Bit 3 (C3). A Don't Care if a 1 to 4 bit length is selected.

Bit 2 : Receive Spare Code Definition Bit 2 (C2). A Don't Care if a 1 to 5 bit length is selected.

Bit 1 : Receive Spare Code Definition Bit 1 (C1). A Don't Care if a 1 to 6 bit length is selected.

Bit 0 : Receive Spare Code Definition Bit 0 (C0). A Don't Care if a 1 to 7 bit length is selected.

Register Name: **T1RSCD2**
 Register Description: **Receive Spare Code Definition Register 2**
 Register Address: **09DH + (200h x n): where n = 0 to 7, for Ports 1 to 8**

Bit #	7	6	5	4	3	2	1	0
Name	C7	C6	C5	C4	C3	C2	C1	C0
Default	0	0	0	0	0	0	0	0

Bit 7 : Receive Spare Code Definition Bit 7 (C7). A Don't Care if a 1 to 7 bit length is selected.

Bit 6 : Receive Spare Code Definition Bit 6 (C6). A Don't Care if a 1 to 7 bit length is selected.

Bit 5 : Receive Spare Code Definition Bit 5 (C5). A Don't Care if a 1 to 7 bit length is selected.

Bit 4 : Receive Spare Code Definition Bit 4 (C4). A Don't Care if a 1 to 7 bit length is selected.

Bit 3 : Receive Spare Code Definition Bit 3 (C3). A Don't Care if a 1 to 7 bit length is selected.

Bit 2 : Receive Spare Code Definition Bit 2 (C2). A Don't Care if a 1 to 7 bit length is selected.

Bit 1 : Receive Spare Code Definition Bit 1 (C1). A Don't Care if a 1 to 7 bit length is selected.

Bit 0 : Receive Spare Code Definition Bit 0 (C0). A Don't Care if a 1 to 7 bit length is selected.

Register Name: **RIIR**
 Register Description: **Receive Interrupt Information Register**
 Register Address: **9FH + (200h x n): where n = 0 to 7, for Ports 1 to 8**

Bit #	7	6	5	4	3	2	1	0
Name	-	RLS7	RLS6*	RLS5	RLS4	RLS3	RLS2**	RLS1
Default	0	0	0	0	0	0	0	0

* RLS6 is reserved for future use.

** Currently RLS2 does not create an interrupt therefore this bit is not used in T1 mode.

The Interrupt Information Registers indicate which of the DS26528 status registers are generating an interrupt. When an interrupt occurs, the host can read RIIR to quickly identify which of the receive status registers is (are) causing the interrupt(s). The Interrupt Information Register bits will clear once the appropriate interrupt has been serviced and cleared, as long as no additional, unmasked interrupt condition is present in the associated status register. Status bits that have been masked via the Receive Interrupt Mask (RIMx) registers, will also be masked from the RIIR register.

Register Name: **RIM1**
 Register Description: **Receive Interrupt Mask Register 1**
 Register Address: **0A0H + (200h x n): where n = 0 to 7, for Ports 1 to 8**

Bit #	7	6	5	4	3	2	1	0
Name	RRAIC	RAISC	RLOSC	RLOFC	RRAID	RAISD	RLOSD	RLOFD
Default	0	0	0	0	0	0	0	0

Bit 7 : Receive Remote Alarm Indication Condition Clear (RRAIC).

0 = interrupt masked

1 = interrupt enabled

Bit 6 : Receive Alarm Indication Signal Condition Clear (RAISC).

0 = interrupt masked

1 = interrupt enabled

Bit 5 : Receive Loss of Signal Condition Clear (RLOSC).

0 = interrupt masked

1 = interrupt enabled

Bit 4 : Receive Loss of Frame Condition Clear (RLOFC).

0 = interrupt masked

1 = interrupt enabled

Bit 3 : Receive Remote Alarm Indication Condition Detect (RRAID).

0 = interrupt masked

1 = interrupt enabled

Bit 2 : Receive Alarm Indication Signal Condition Detect (RAISD).

0 = interrupt masked

1 = interrupt enabled

Bit 1 : Receive Loss of Signal Condition Detect (RLOSD).

0 = interrupt masked

1 = interrupt enabled

Bit 0 : Receive Loss of Frame Condition Detect (RLOFD).

0 = interrupt masked

1 = interrupt enabled

Register Name: **RIM2 – E1 Mode Only**
 Register Description: **E1 Receive Interrupt Mask Register 2**
 Register Address: **0A1H + (200h x n): where n = 0 to 7, for Ports 1 to 8**

Bit #	7	6	5	4	3	2	1	0
Name	-	-	-	-	RSA1	RSA0	RCMF	RAF
Default	0	0	0	0	0	0	0	0

Bit 3 : Receive Signaling All Ones Event (RSA1).

0 = interrupt masked
 1 = interrupt enabled

Bit 2 : Receive Signaling All Zeros Event (RSA0).

0 = interrupt masked
 1 = interrupt enabled

Bit 1 : Receive CRC4 Multiframe Event (RCMF).

0 = interrupt masked
 1 = interrupt enabled

Bit 0 : Receive Align Frame Event (RAF).

0 = interrupt masked
 1 = interrupt enabled

Register Name: **RIM3 – T1 Mode**
 Register Description: **Receive Interrupt Mask Register 3**
 Register Address: **0A2H + (200h x n): where n = 0 to 7, for Ports 1 to 8**

Bit #	7	6	5	4	3	2	1	0
Name	LORCC	LSPC	LDNC	LUPC	LORCD	LSPD	LDND	LUPD
Default	0	0	0	0	0	0	0	0

Bit 7 : Loss of Receive Clock Condition Clear (LORCC).

0 = interrupt masked
 1 = interrupt enabled

Bit 6 : Spare Code Detected Condition Clear (LSPC).

0 = interrupt masked
 1 = interrupt enabled

Bit 5 : Loop Down Code Detected Condition Clear(LDNC).

0 = interrupt masked
 1 = interrupt enabled

Bit 4 : Loop Up Code Detected Condition Clear (LUPC).

0 = interrupt masked
 1 = interrupt enabled

Bit 3 : Loss of Receive Clock Condition Detect (LORCD).

0 = interrupt masked
 1 = interrupt enabled

Bit 2 : Spare Code Detected Condition Detect (LSPD).

0 = interrupt masked
 1 = interrupt enabled

Bit 1 : Loop Down Code Detected Condition Detect (LDND).

0 = interrupt masked
 1 = interrupt enabled

Bit 0 : Loop Up Code Detected Condition Detect (LUPD).

0 = interrupt masked
 1 = interrupt enabled

Register Name: **RIM3 – E1 Mode**
 Register Description: **E1 Receive Interrupt Mask Register 3**
 Register Address: **0A2H + (200h x n): where n = 0 to 7, for Ports 1 to 8**

Bit #	7	6	5	4	3	2	1	0
Name	LORCC	-	V52LNKC	RDMAC	LORCD	-	V52LNKD	RDMAD
Default	0	0	0	0	0	0	0	0

Bit 7 : Loss of Receive Clock Clear (LORCC).

0 = interrupt masked
 1 = interrupt enabled

Bit 5 : V5.2 Link Detected Clear (V52LNKC).

0 = interrupt masked
 1 = interrupt enabled

Bit 4 : Receive Distant MF Alarm Clear (RDMAC).

0 = interrupt masked
 1 = interrupt enabled

Bit 3 : Loss of Receive Clock Detect (LORCD).

0 = interrupt masked
 1 = interrupt enabled

Bit 1 : V5.2 Link Detect (V52LNKD).

0 = interrupt masked
 1 = interrupt enabled

Bit 0 : Receive Distant MF Alarm Detect (RDMAD).

0 = interrupt masked
 1 = interrupt enabled

Register Name: **RIM4**
 Register Description: **Receive Interrupt Mask Register 4**
 Register Address: **0A3H + (200h x n): where n = 0 to 7, for Ports 1 to 8**

Bit #	7	6	5	4	3	2	1	0
Name	RESF	RESEM	RSLIP	-	RSCOS	1SEC	TIMER	RMF
Default	0	0	0	0	0	0	0	0

Bit 7 : Receive Elastic Store Full Event (RESF).

0 = interrupt masked
 1 = interrupt enabled

Bit 6 : Receive Elastic Store Empty Event (RESEM).

0 = interrupt masked
 1 = interrupt enabled

Bit 5 : Receive Elastic Store Slip Occurrence Event (RSLIP).

0 = interrupt masked
 1 = interrupt enabled

Bit 3 : Receive Signaling Change Of State Event (RSCOS).

0 = interrupt masked
 1 = interrupt enabled

Bit 2 : One Second Timer (1SEC).

0 = interrupt masked
 1 = interrupt enabled

Bit 1 : Timer Event (TIMER).

0 = interrupt masked
 1 = interrupt enabled

Bit 0 : Receive Multiframe Event (RMF).

0 = interrupt masked
 1 = interrupt enabled

Register Name: **RIM5**
 Register Description: **Receive Interrupt Mask 5 (HDLC)**
 Register Address: **0A4H + (200h x n): where n = 0 to 7, for Ports 1 to 8**

Bit #	7	6	5	4	3	2	1	0
Name	-	-	ROVR	RHOBT	RPE	RPS	RHWMS	RNES
Default	0	0	0	0	0	0	0	0

Bit 5 : Receive FIFO Overrun (ROVR).

0 = interrupt masked
 1 = interrupt enabled

Bit 4 : Receive HDLC Opening Byte Event (RHOBT).

0 = interrupt masked
 1 = interrupt enabled

Bit 3 : Receive Packet End Event (RPE).

0 = interrupt masked
 1 = interrupt enabled

Bit 2 : Receive Packet Start Event (RPS).

0 = interrupt masked
 1 = interrupt enabled

Bit 1 : Receive FIFO Above High Watermark Set Event (RHWMS).

0 = interrupt masked
 1 = interrupt enabled

Bit 0 : Receive FIFO Not Empty Set Event (RNES).

0 = interrupt masked
 1 = interrupt enabled

Register Name: **RIM7 – T1 Mode Only**
 Register Description: **Receive Interrupt Mask Register 7 (BOC:FDL)**
 Register Address: **A6H + (200h x n): where n = 0 to 7, for Ports 1 to 8**

Bit #	7	6	5	4	3	2	1	0
Name	-	-	RRAI-CI	RAIS-CI	RSLC96	RFDLF	BC	BD
Default	0	0	0	0	0	0	0	0

Bit 5 : Receive RAI-CI (RRAI-CI).

0 = interrupt masked
 1 = interrupt enabled

Bit 4 : Receive AIS-CI (RAIS-CI).

0 = interrupt masked
 1 = interrupt enabled

Bit 3 : Receive SLC-96 (RSLC96).

0 = interrupt masked
 1 = interrupt enabled

Bit 2 : Receive FDL Register Full (RFDLF).

0 = interrupt masked
 1 = interrupt enabled

Bit 1 : BOC Clear Event (BC).

0 = interrupt masked
 1 = interrupt enabled

Bit 0 : BOC Detect Event (BD).

0 = interrupt masked
 1 = interrupt enabled

Register Name: **RSCSE1, RSCSE2, RSCSE3, RSCSE4**
 Register Description: **Receive Signaling Change of State Enable**
 Register Address: **0A8H, 0A9H, 0AAH, 0ABH + (200h x n): where n = 0 to 7, for Ports 1 to 8**

(MSB)							(LSB)	
CH8	CH7	CH6	CH5	CH4	CH3	CH2	CH1	RSCSE1
CH16	CH15	CH14	CH13	CH12	CH11	CH10	CH9	RSCSE2
CH24	CH23	CH22	CH21	CH20	CH19	CH18	CH17	RSCSE3
CH32	CH31	CH30	CH29	CH28	CH27	CH26	CH25	RSCSE4 (E1 Only)

Setting any of the CH1 through CH32 bits in the RSS1 through RSS4 registers will cause RSCOS (RLSR4.3) to be set when that channel's signaling data changes state.

Register Name: **T1RUPCD1**
 Register Description: **Receive Up Code Definition Register 1**
 Register Address: **0ACH + (200h x n): where n = 0 to 7, for Ports 1 to 8**

Bit #	7	6	5	4	3	2	1	0
Name	C7	C6	C5	C4	C3	C2	C1	C0
Default	0	0	0	0	0	0	0	0

Note: Writing this register resets the detector's integration period.

Bit 7 : Receive Up Code Definition Bit 7 (C7). First bit of the repeating pattern.

Bit 6 : Receive Up Code Definition Bit 6 (C6). A Don't Care if a 1-bit length is selected.

Bit 5 : Receive Up Code Definition Bit 5 (C5). A Don't Care if a 1 or 2 bit length is selected.

Bit 4 : Receive Up Code Definition Bit 4 (C4). A Don't Care if a 1 to 3 bit length is selected.

Bit 3 : Receive Up Code Definition Bit 3 (C3). A Don't Care if a 1 to 4 bit length is selected.

Bit 2 : Receive Up Code Definition Bit 2 (C2). A Don't Care if a 1 to 5 bit length is selected.

Bit 1 : Receive Up Code Definition Bit 1 (C1). A Don't Care if a 1 to 6 bit length is selected.

Bit 0 : Receive Up Code Definition Bit 0 (C0). A Don't Care if a 1 to 7 bit length is selected.

Register Name: **T1RUPCD2**
 Register Description: **Receive Up Code Definition Register 2**
 Register Address: **0ADH + (200h x n): where n = 0 to 7, for Ports 1 to 8**

Bit #	7	6	5	4	3	2	1	0
Name	C7	C6	C5	C4	C3	C2	C1	C0
Default	0	0	0	0	0	0	0	0

Bit 7 : Receive Up Code Definition Bit 7 (C7). A Don't Care if a 1 to 7 bit length is selected.

Bit 6 : Receive Up Code Definition Bit 6 (C6). A Don't Care if a 1 to 7 bit length is selected.

Bit 5 : Receive Up Code Definition Bit 5 (C5). A Don't Care if a 1 to 7 bit length is selected.

Bit 4 : Receive Up Code Definition Bit 4 (C4). A Don't Care if a 1 to 7 bit length is selected.

Bit 3 : Receive Up Code Definition Bit 3 (C3). A Don't Care if a 1 to 7 bit length is selected.

Bit 2 : Receive Up Code Definition Bit 2 (C2). A Don't Care if a 1 to 7 bit length is selected.

Bit 1 : Receive Up Code Definition Bit 1 (C1). A Don't Care if a 1 to 7 bit length is selected.

Bit 0 : Receive Up Code Definition Bit 0 (C0). A Don't Care if a 1 to 7 bit length is selected.

Register Name: **T1RDNCD1**
 Register Description: **Receive Down Code Definition Register 1**
 Register Address: **0AEH + (200h x n): where n = 0 to 7, for Ports 1 to 8**

Bit #	7	6	5	4	3	2	1	0
Name	C7	C6	C5	C4	C3	C2	C1	C0
Default	0	0	0	0	0	0	0	0

Note: Writing this register resets the detector's integration period.

Bit 7 : Receive Down Code Definition Bit 7 (C7). First bit of the repeating pattern.

Bit 6 : Receive Down Code Definition Bit 6 (C6). A Don't Care if a 1-bit length is selected.

Bit 5 : Receive Down Code Definition Bit 5 (C5). A Don't Care if a 1 or 2 bit length is selected.

Bit 4 : Receive Down Code Definition Bit 4 (C4). A Don't Care if a 1 to 3 bit length is selected.

Bit 3 : Receive Down Code Definition Bit 3 (C3). A Don't Care if a 1 to 4 bit length is selected.

Bit 2 : Receive Down Code Definition Bit 2 (C2). A Don't Care if a 1 to 5 bit length is selected.

Bit 1 : Receive Down Code Definition Bit 1 (C1). A Don't Care if a 1 to 6 bit length is selected.

Bit 0 : Receive Down Code Definition Bit 0 (C0). A Don't Care if a 1 to 7 bit length is selected.

Register Name: **T1RDNCD2**
 Register Description: **Receive Down Code Definition Register 2**
 Register Address: **0AFH + (200h x n): where n = 0 to 7, for Ports 1 to 8**

Bit #	7	6	5	4	3	2	1	0
Name	C7	C6	C5	C4	C3	C2	C1	C0
Default	0	0	0	0	0	0	0	0

Bit 7 : Receive Down Code Definition Bit 7 (C7). A Don't Care if a 1 to 7 bit length is selected.

Bit 6 : Receive Down Code Definition Bit 6 (C6). A Don't Care if a 1 to 7 bit length is selected.

Bit 5 : Receive Down Code Definition Bit 5 (C5). A Don't Care if a 1 to 7 bit length is selected.

Bit 4 : Receive Down Code Definition Bit 4 (C4). A Don't Care if a 1 to 7 bit length is selected.

Bit 3 : Receive Down Code Definition Bit 3 (C3). A Don't Care if a 1 to 7 bit length is selected.

Bit 2 : Receive Down Code Definition Bit 2 (C2). A Don't Care if a 1 to 7 bit length is selected.

Bit 1 : Receive Down Code Definition Bit 1 (C1). A Don't Care if a 1 to 7 bit length is selected.

Bit 0 : Receive Down Code Definition Bit 0 (C0). A Don't Care if a 1 to 7 bit length is selected.

Register Name: **RRTS1**
 Register Description: **Receive Real-Time Status Register 1**
 Register Address: **0B0H + (200h x n): where n = 0 to 7, for Ports 1 to 8**

Bit #	7	6	5	4	3	2	1	0
Name	--	--	--	--	RRAI	RAIS	RLOS	RLOF
Default	0	0	0	0	0	0	0	0

All bits in this register are real-time (not latched).

Bit 3 : Receive Remote Alarm Indication Condition (RRAI). Set when a remote alarm is received at RPOS and RNEG.

Bit 2 : Receive Alarm Indication Signal Condition (RAIS). Set when an unframed all one's code is received at RPOS and RNEG.

Bit 1 : Receive Loss of Signal Condition (RLOS). Set when 192 consecutive zeros have been detected at RPOS and RNEG.

Bit 0 : Receive Loss of Frame Condition (RLOF). Set when the DS26528 is not synchronized to the received data stream.

Register Name: **RRTS3 – T1 Mode**
 Register Description: **Receive Real-Time Status Register 3**
 Register Address: **0B2H + (200h x n): where n = 0 to 7, for Ports 1 to 8**

Bit #	7	6	5	4	3	2	1	0
Name	--	--	--	--	LORC	LSP	LDN	LUP
Default	0	0	0	0	0	0	0	0

All bits in this register are real-time (not latched).

Bit 3 : Loss of Receive Clock Condition (LORC). Set when the RCLK pin has not transitioned for one channel time.

Bit 2 : Spare Code Detected Condition (LSP). Set when the spare code as defined in the RSCD1/2 registers is being received.

Bit 1 : Loop Down Code Detected Condition (LDN). Set when the loop down code as defined in the RDNCD1/2 register is being received.

Bit 0 : Loop Up Code Detected Condition (LUP). Set when the loop up code as defined in the RUPCD1/2 register is being received.

Register Name: **RRTS3 – E1 Mode**
 Register Description: **Receive Real-Time Status Register 3**
 Register Address: **0B2H**

Bit #	7	6	5	4	3	2	1	0
Name	-	-	-	-	LORC	-	V52LNK	RDMA
Default	0	0	0	0	0	0	0	0

Note: All bits in this register are real-time (not latched).

Bit 3 : Loss of Receive Clock Condition (LORC). Set when the RCLK pin has not transitioned for one channel time.

Bit 1 : V5.2 Link Detected Condition (V52LNK). Set on detection of a V5.2 link identification signal. (G.965).

Bit 0 : Receive Distant MF Alarm Condition (RDMA). Set when bit-6 of time slot 16 in frame 0 has been set for two consecutive multiframes. This alarm is not disabled in the CCS signaling mode.

Register Name: **RRTS5**
 Register Description: **Receive Real-Time Status Register 5 (HDLC)**
 Register Address: **0B4H + (200h x n): where n = 0 to 7, for Ports 1 to 8**

Bit #	7	6	5	4	3	2	1	0
Name	-	PS2	PS1	PS0	-	-	RHWM	RNE
Default	0	0	0	0	0	0	0	0

All bits in this register are real time.

Bits 6 to 4 : Receive Packet Status (PS0 to PS2). These are real-time bits indicating the status as of the last read of the receive FIFO.

PS2	PS1	PS0	PACKET STATUS
0	0	0	In Progress: End of message has not yet been reached.
0	0	1	Packet OK: Packet ended with correct CRC codeword.
0	1	0	CRC Error: A closing flag was detected, preceded by a corrupt CRC codeword.
0	1	1	Abort: Packet ended because an abort signal was detected. (7 or more ones in a row).
1	0	0	Overrun: HDLC controller terminated reception of packet because receive FIFO is full.

Bit 1 : Receive FIFO Above High Watermark Condition (RHWM). Set when the receive 64-byte FIFO fills beyond the high watermark as defined by the Receive HDLC FIFO Control Register (RHFC). This is a real-time bit.

Bit 0 : Receive FIFO Not Empty Condition (RNE). Set when the receive 64-byte FIFO has at least one byte available for a read. This is a real-time bit.

Register Name: **RHPBA**
 Register Description: **Receive HDLC Packet Bytes Available Register**
 Register Address: **0B5H + (200h x n): where n = 0 to 7, for Ports 1 to 8**

Bit #	7	6	5	4	3	2	1	0
Name	MS	RPBA6	RPBA5	RPBA4	RPBA3	RPBA2	RPBA1	RPBA0
Default	0	0	0	0	0	0	0	0

Bit 7 : Message Status (MS).

0 = Bytes indicated by RPBA0 through RPBA6 are the end of a message. Host must check the HDLC Status register for details.

1 = Bytes indicated by RPBA0 through RPBA6 are the beginning or continuation of a message. The host does not need to check the HDLC Status. The MS bit will return to a value of '1' when the Rx HDLC FIFO is empty.

Bits 6 to 0 : Receive FIFO Packet Bytes Available Count (RPBA6 to RPBA0). RPBA0 is the LSB.

Register Name: **RHF**
 Register Description: **Receive HDLC FIFO Register**
 Register Address: **0B6H + (200h x n): where n = 0 to 7, for Ports 1 to 8**

Bit #	7	6	5	4	3	2	1	0
Name	RHD7	RHD6	RHD5	RHD4	RHD3	RHD2	RHD1	RHD0
Default	0	0	0	0	0	0	0	0

Bit 7 : Receive HDLC Data Bit 7 (RHD7). MSB of a HDLC packet data byte.

Bit 6 : Receive HDLC Data Bit 6 (RHD6).

Bit 5 : Receive HDLC Data Bit 5 (RHD5).

Bit 4 : Receive HDLC Data Bit 4 (RHD4).

Bit 3 : Receive HDLC Data Bit 3 (RHD3).

Bit 2 : Receive HDLC Data Bit 2 (RHD2).

Bit 1 : Receive HDLC Data Bit 1 (RHD1).

Bit 0 : Receive HDLC Data Bit 0 (RHD0). LSB of a HDLC packet data byte.

Register Name: **RBCS1, RBCS2, RBCS3, RBCS4**
 Register Description: **Receive Blank Channel Select Registers**
 Register Address: **0C0H, 0C1H, 0C2H, 0C3H + (200h x n): where n = 0 to 7, for Ports 1 to 8**

Bit #	7	6	5	4	3	2	1	0	
Name	CH8	CH7	CH6	CH5	CH4	CH3	CH2	CH1	RBCS1
Name	CH16	CH15	CH14	CH13	CH12	CH11	CH10	CH9	RBCS2
Name	CH24	CH23	CH22	CH21	CH20	CH19	CH18	CH17	RBCS3
Name	CH32	CH31	CH30	CH29	CH28	CH27	CH26	CH25	RBCS4
Default	0	0	0	0	0	0	0	0	

Bit 7 to 0 : Receive Blank Channel Select for Channels 32 to 1 (CH1-32).

0 = do not blank this channel (channel data is available on RSER)

1 = data on RSER is forced to all ones for this channel

Note that when two or more sequential channels are chosen to be blanked, the receive slip zone select bit should be set to zero. If the blank channels are distributed (such as 1, 5, 9, 13, 17, 21, 25, 29) then the RSZS bit can be set to one, which may provide a lower occurrence of slips in certain applications.

Register Name: **RCBR1, RCBR2, RCBR3, RCBR4**
 Register Description: **Receive Channel Blocking Registers**
 Register Address: **0C4H, 0C5H, 0C6H, 0C7H + (200h x n): where n = 0 to 7, for Ports 1 to 8**

Bit #	7	6	5	4	3	2	1	0	
Name	CH8	CH7	CH6	CH5	CH4	CH3	CH2	CH1	RCBR1
Name	CH16	CH15	CH14	CH13	CH12	CH11	CH10	CH9	RCBR2
Name	CH24	CH23	CH22	CH21	CH20	CH19	CH18	CH17	RCBR3
Name	CH32	CH31	CH30	CH29	CH28	CH27	CH26	CH25 (Fbit)	RCBR4
Default	0	0	0	0	0	0	0	0	

Bits 7 to 0 : Channel Blocking Control Bits for Receive Channels 32 to 1 (CH32 – CH1).

0 = force the RCHBLK pin to remain low during this channel time

1 = force the RCHBLK pin high during this channel time

*** Note that RCBR4 has two functions:**

When 2.048MHz backplane mode is selected, this register allows the user to enable the channel blocking signal for any of the 32 possible backplane channels.

When 1.544MHz backplane mode is selected, the LSB of this register determines whether or not the RCHBLK signal will pulse high during the F-Bit time. In this mode RCBR4.1 to RCBR4.7 should be set to '0'.

RCBR4.0 = 0, do not pulse RCHBLK during the F-Bit

RCBR4.0 = 1, pulse RCHBLK during the F-Bit

Register Name: **RSI1, RSI2, RSI3, RSI4**
 Register Description: **Receive Signaling Reinsertion Enable Registers**
 Register Address: **0C8H, 0C9H, 0CAH, 0CBH + (200h x n): where n = 0 to 7, for Ports 1 to 8**

Bit #	7	6	5	4	3	2	1	0	
Name	CH8	CH7	CH6	CH5	CH4	CH3	CH2	CH1	RSI1
Name	CH16	CH15	CH14	CH13	CH12	CH11	CH10	CH9	RSI2
Name	CH24	CH23	CH22	CH21	CH20	CH19	CH18	CH17	RSI3
Name	CH32	CH31	CH30	CH29	CH28	CH27	CH26	CH25	RSI4
Default	0	0	0	0	0	0	0	0	

Setting any of the CH1 through CH24 bits in the RSI1 through RSI4 registers will cause signaling data to be reinserted for the associated channel. RSI4 is used for 2.048MHz backplane operation.

Register Name: **RGCCS1, RGCCS2, RGCCS3, RGCCS4**
 Register Description: **Receive Gapped Clock Channel Select Registers**
 Register Address: **0CCH, 0CDH, 0CEH, 0CFH + (200h x n): where n = 0 to 7, for Ports 1 to 8**

Bit #	7	6	5	4	3	2	1	0	
Name	CH8	CH7	CH6	CH5	CH4	CH3	CH2	CH1	RGCCS1
Name	CH16	CH15	CH14	CH13	CH12	CH11	CH10	CH9	RGCCS2
Name	CH24	CH23	CH22	CH21	CH20	CH19	CH18	CH17	RGCCS3
Name	CH32	CH31	CH30	CH29	CH28	CH27	CH26	CH25 (Fbit)	RGCCS4
Default	0	0	0	0	0	0	0	0	

Bits 7 to 0 : Gapped Clock Channel Select Bits for Receive Channels 32 to 1(CH32 – CH1).

0 = no clock is present on RCHCLK during this channel time

1 = force a clock on RCHCLK during this channel time. The clock will be synchronous with RCLK if the elastic store is disabled, and synchronous with RSYCLK if the elastic store is enabled.

*** Note that RGCCS4 has two functions:**

When 2.048MHz backplane mode is selected, this register allows the user to enable the 'gapped' clock on RCHCLK for any of the 32 possible backplane channels.

When 1.544MHz backplane mode is selected, the LSB of this register determines whether or not a clock is generated on RCHCLK during the F-Bit time:

RGCCS4.0 = 0, do not generate a clock during the F-Bit

RGCCS4.0 = 1, generate a clock during the F-Bit

In this mode RGCCS4.1 to RGCCS4.7 should be set to '0'.

Register Name: **RCICE1, RCICE2, RCICE3, RCICE4**
 Register Description: **Receive Channel Idle Code Enable Registers**
 Register Address: **0D0H, 0D1H, 0D2H, 0D3H + (200h x n): where n = 0 to 7, for Ports 1 to 8**

(MSB)							(LSB)	
CH8	CH7	CH6	CH5	CH4	CH3	CH2	CH1	RCICE1
CH16	CH15	CH14	CH13	CH12	CH11	CH10	CH9	RCICE2
CH24	CH23	CH22	CH21	CH20	CH19	CH18	CH17	RCICE3
CH32	CH31	CH30	CH29	CH28	CH27	CH26	CH25	RCICE4

Bits 7 to 0 : Receive Channels 1 to 32 Code Insertion Control Bits (CH1 to CH32)

0 = do not insert data from the Idle Code Array into the receive data stream

1 = insert data from the Idle Code Array into the receive data stream

Register Name: **RBPCS1, RBPCS2, RBPCS3, RBPCS4**
 Register Description: **Receive BERT Port Channel Select Registers**
 Register Address: **0D4H, 0D5H, 0D6H, 0D7H + (200h x n): where n = 0 to 7, for Ports 1 to 8**

(MSB)							(LSB)	
CH8	CH7	CH6	CH5	CH4	CH3	CH2	CH1	RBPCS1
CH16	CH15	CH14	CH13	CH12	CH11	CH10	CH9	RBPCS2
CH24	CH23	CH22	CH21	CH20	CH19	CH18	CH17	RBPCS3
CH32	CH31	CH30	CH29	CH28	CH27	CH26	CH25	RBPCS4

Bits 7 to 0 : BERT Port Channel Select Receive Channels 1 to 32(CH1 to CH32)

0 = Do not enable RBP_CLK for the associated channel time, or map the selected channel data out of the receive BERT Port.

1 = Enable RBP_CLK for the associated channel time, and allow mapping of the selected channel data out of the receive BERT Port. Multiple, or all channels may be selected simultaneously.

10.4.2 Transmit Register Definitions

Register Name: **THC1**
 Register Description: **Transmit HDLC Control Register 1**
 Register Address: **110H + (200h x n): where n = 0 to 7, for Ports 1 to 8**

Bit #	7	6	5	4	3	2	1	0
Name	NOFS	TEOML	THR	THMS	TFS	TEOM	TZSD	TCRCD
Default	0	0	0	0	0	0	0	0

Bit 7 : Number Of Flags Select (NOFS).

- 0 = send one flag between consecutive messages
- 1 = send two flags between consecutive messages

Bit 6 : Transmit End of Message and Loop (TEOML). To loop on a message, should be set to a one just before the last data byte of an HDLC packet is written into the transmit FIFO. The message will repeat until the user clears this bit or a new message is written to the transmit FIFO. If the host clears the bit, the looping message will complete then flags will be transmitted until new message is written to the FIFO. If the host terminates the loop by writing a new message to the FIFO the loop will terminate, one or two flags will be transmitted and the new message will start. If not disabled via TCRCD, the transmitter will automatically append a two-byte CRC code to the end of all messages.

Bit 5 : Transmit HDLC Reset (THR). Will reset the transmit HDLC controller and flush the transmit FIFO. An abort followed by 7Eh or FFh flags/idle will be transmitted until a new packet is initiated by writing new data into the FIFO. This is an acknowledged reset, that is, the host need only to set the bit and the DS26528 will clear it once the reset operation is complete. Total time for the reset is less than 250µs.

- 0 = Normal operation
- 1 = Reset transmit HDLC controller and flush the transmit FIFO

Bit 4 : Transmit HDLC Mapping Select (THMS).

- 0 = Transmit HDLC assigned to channels
- 1 = Transmit HDLC assigned to FDL(T1 mode), Sa Bits(E1 mode). This mode must be enabled with TCR2.7.

Bit 3 : Transmit Flag/Idle Select (TFS). This bit selects the inter-message fill character after the closing and before the opening flags (7Eh).

- 0 = 7Eh
- 1 = FFh

Bit 2 : Transmit End of Message (TEOM). Should be set to a one just before the last data byte of an HDLC packet is written into the transmit FIFO at THF. If not disabled via TCRCD, the transmitter will automatically append a two byte CRC code to the end of the message.

Bit 1 : Transmit Zero Stuffer Defeat (TZSD). The Zero Stuffer function automatically inserts a zero in the message field (between the flags) after 5 consecutive ones to prevent the emulation of a flag or abort sequence by the data pattern. The receiver automatically removes (de-stuffs) any zero after 5 ones in the message field.

- 0 = enable the zero stuffer (normal operation)
- 1 = disable the zero stuffer

Bit 0 : Transmit CRC Defeat (TCRCD). A two-byte CRC code is automatically appended to the outbound message. This bit can be used to disable the CRC function.

- 0 = enable CRC generation (normal operation)
- 1 = disable CRC generation

Register Name: **THBSE**
 Register Description: **Transmit HDLC Bit Suppress**
 Register Address: **111H + (200h x n): where n = 0 to 7, for Ports 1 to 8**

Bit #	7	6	5	4	3	2	1	0
Name	TBSE8	TBSE7	TBSE6	TBSE5	TBSE4	TBSE3	TBSE2	TBSE1
Default	0	0	0	0	0	0	0	0

Bit 7 : Transmit Bit 8 Suppress (TBSE8). MSB of the channel. Set to one to stop this bit from being used.

Bit 6 : Transmit Bit 7 Suppress (TBSE7). Set to one to stop this bit from being used.

Bit 5 : Transmit Bit 6 Suppress (TBSE6). Set to one to stop this bit from being used.

Bit 4 : Transmit Bit 5 Suppress (TBSE5). Set to one to stop this bit from being used

Bit 3 : Transmit Bit 4 Suppress (TBSE4). Set to one to stop this bit from being used

Bit 2 : Transmit Bit 3 Suppress (TBSE3). Set to one to stop this bit from being used

Bit 1 : Transmit Bit 2 Suppress (TBSE2). Set to one to stop this bit from being used

Bit 0 : Transmit Bit 1 Suppress (TBSE1). LSB of the channel. Set to one to stop this bit from being used.

Register Name: **THC2**
 Register Description: **Transmit HDLC Control Register 2**
 Register Address: **113H + (200h x n): where n = 0 to 7, for Ports 1 to 8**

Bit #	7	6	5	4	3	2	1	0
Name	TABT	SBOC	THCEN	THCS4	THCS3	THCS2	THCS1	THCS0
Default	0	0	0	0	0	0	0	0

Bit 7 : Transmit Abort (TABT). A 0-to-1 transition will cause the FIFO contents to be dumped and one FEh abort to be sent followed by 7Eh or FFh flags/idle until a new packet is initiated by writing new data into the FIFO. Must be cleared and set again for a subsequent abort to be sent.

Bit 6 : Send BOC (SBOC). T1 Mode Only. Set = 1 to transmit the BOC code placed in bits 0 to 5 of the TBOC register.

Bit 5 : Transmit HDLC Controller Enable (THCEN).

0 = Transmit HDLC Controller is not enabled

1 = Transmit HDLC Controller is enabled

Bits 4 to 0 : Transmit HDLC Channel Select (THCS4-0). Determines which DSO channel will carry the HDLC message if enabled. Changes to this value are acknowledged only upon a transmit HDLC controller reset (THR at THC1.5).

Register Name: **E1TSACR**
 Register Description: **E1 Transmit Sa Bit Control Register**
 Register Address: **114h + (200h * n) : where n = 0 to 7, for Ports 1 to 8**

Bit #	7	6	5	4	3	2	1	0
Name	SiAF	SiNAF	RA	Sa4	Sa5	Sa6	Sa7	Sa8
Default	0	0	0	0	0	0	0	0

Bit 7 : International Bit in Align Frame Insertion Control Bit (SiAF).

0 = do not insert data from the TSiAF register into the transmit data stream
 1 = insert data from the TSiAF register into the transmit data stream

Bit 6 : International Bit in Non-Align Frame Insertion Control Bit (SiNAF).

0 = do not insert data from the TSiNAF register into the transmit data stream
 1 = insert data from the TSiNAF register into the transmit data stream

Bit 5 : Remote Alarm Insertion Control Bit (RA).

0 = do not insert data from the TRA register into the transmit data stream
 1 = insert data from the TRA register into the transmit data stream

Bit 4 : Additional Bit 4 Insertion Control Bit (Sa4).

0 = do not insert data from the TSa4 register into the transmit data stream
 1 = insert data from the TSa4 register into the transmit data stream

Bit 3 : Additional Bit 5 Insertion Control Bit (Sa5).

0 = do not insert data from the TSa5 register into the transmit data stream
 1 = insert data from the TSa5 register into the transmit data stream

Bit 2 : Additional Bit 6 Insertion Control Bit (Sa6).

0 = do not insert data from the TSa6 register into the transmit data stream
 1 = insert data from the TSa6 register into the transmit data stream

Bit 1 : Additional Bit 7 Insertion Control Bit (Sa7).

0 = do not insert data from the TSa7 register into the transmit data stream
 1 = insert data from the TSa7 register into the transmit data stream

Bit 0 : Additional Bit 8 Insertion Control Bit (Sa8).

0 = do not insert data from the TSa8 register into the transmit data stream
 1 = insert data from the TSa8 register into the transmit data stream

Register Name: **SSIE1, SSIE2, SSIE3, SSIE4**
 Register Description: **Software Signaling Insertion Enable Registers**
 Register Address: **118H, 119H, 11AH, 11BH + (200h x n): where n = 0 to 7, for Ports 1 to 8**

(MSB)							(LSB)	
CH8	CH7	CH6	CH5	CH4	CH3	CH2	CH1	SSIE1
CH16	CH15	CH14	CH13	CH12	CH11	CH10	CH9	SSIE2
CH24	CH23	CH22	CH21	CH20	CH19	CH18	CH17	SSIE3
CH32	CH31	CH30	CH29	CH28	CH27	CH26	CH25	SSIE4

Bits 7 to 0 : Software Signaling Insertion Enable for Channels 1 to 32 (SSIE_x). These bits determine which channels are to have signaling inserted from the Transmit Signaling registers.

0 = do not source signaling data from the TS registers for this channel

1 = source signaling data from the TS registers for this channel

Register Name: **TIDR1 to TIDR32**
 Register Description: **Transmit Idle Code Definition Registers 1 to 32**
 Register Address: **120H to 13FH + (200h x n): where n = 0 to 7, for Ports 1 to 8**

Bit #	7	6	5	4	3	2	1	0
Name	C7	C6	C5	C4	C3	C2	C1	C0
Default	0	0	0	0	0	0	0	0

Bits 7 to 0 : Per-Channel Idle Code Bits (C7 to C0). C0 is the LSB of the Code (this bit is transmitted last). Address 120H is for channel 1, address 13FH is for channel 32.

Register Name: **TS1 to TS16**
 Register Description: **Transmit Signaling Registers**
 Register Address: **140H – 14FH + (200h x n): where n = 0 to 7, for Ports 1 to 8**

T1 Mode:

(MSB)							(LSB)	
CH1-A	CH1-B	CH1-C	CH1-D	CH13-A	CH13-B	CH13-C	CH13-D	TS1
CH2-A	CH2-B	CH2-C	CH2-D	CH14-A	CH14-B	CH14-C	CH14-D	TS2
CH3-A	CH3-B	CH3-C	CH3-D	CH15-A	CH15-B	CH15-C	CH15-D	TS3
CH4-A	CH4-B	CH4-C	CH4-D	CH16-A	CH16-B	CH16-C	CH16-D	TS4
CH5-A	CH5-B	CH5-C	CH5-D	CH17-A	CH17-B	CH17-C	CH17-D	TS5
CH6-A	CH6-B	CH6-C	CH6-D	CH18-A	CH18-B	CH18-C	CH18-D	TS6
CH7-A	CH7-B	CH7-C	CH7-D	CH19-A	CH19-B	CH19-C	CH19-D	TS7
CH8-A	CH8-B	CH8-C	CH8-D	CH20-A	CH20-B	CH20-C	CH20-D	TS8
CH9-A	CH9-B	CH9-C	CH9-D	CH21-A	CH21-B	CH21-C	CH21-D	TS9
CH10-A	CH10-B	CH10-C	CH10-D	CH22-A	CH22-B	CH22-C	CH22-D	TS10
CH11-A	CH11-B	CH11-C	CH11-D	CH23-A	CH23-B	CH23-C	CH23-D	TS11
CH12-A	CH12-B	CH12-C	CH12-D	CH24-A	CH24-B	CH24-C	CH24-D	TS12

Note: In D4 framing mode, the C and D bits are not used.

E1 Mode:

(MSB)							(LSB)	
0	0	0	0	X	Y	X	X	TS1
CH1-A	CH1-B	CH1-C	CH1-D	CH16-A	CH16-B	CH16-C	CH16-D	TS2
CH2-A	CH2-B	CH2-C	CH2-D	CH17-A	CH17-B	CH17-C	CH17-D	TS3
CH3-A	CH3-B	CH3-C	CH3-D	CH18-A	CH18-B	CH18-C	CH18-D	TS4
CH4-A	CH4-B	CH4-C	CH4-D	CH19-A	CH19-B	CH19-C	CH19-D	TS5
CH5-A	CH5-B	CH5-C	CH5-D	CH20-A	CH20-B	CH20-C	CH20-D	TS6
CH6-A	CH6-B	CH6-C	CH6-D	CH21-A	CH21-B	CH21-C	CH21-D	TS7
CH7-A	CH7-B	CH7-C	CH7-D	CH22-A	CH22-B	CH22-C	CH22-D	TS8
CH8-A	CH8-B	CH8-C	CH8-D	CH23-A	CH23-B	CH23-C	CH23-D	TS9
CH9-A	CH9-B	CH9-C	CH9-D	CH24-A	CH24-B	CH24-C	CH24-D	TS10
CH10-A	CH10-B	CH10-C	CH10-D	CH25-A	CH25-B	CH25-C	CH25-D	TS11
CH11-A	CH11-B	CH11-C	CH11-D	CH26-A	CH26-B	CH26-C	CH26-D	TS12
CH12-A	CH12-B	CH12-C	CH12-D	CH27-A	CH27-B	CH27-C	CH27-D	TS13
CH13-A	CH13-B	CH13-C	CH13-D	CH28-A	CH28-B	CH28-C	CH28-D	TS14
CH14-A	CH14-B	CH14-C	CH14-D	CH29-A	CH29-B	CH29-C	CH29-D	TS15
CH15-A	CH15-B	CH15-C	CH15-D	CH30-A	CH30-B	CH30-C	CH30-D	TS16

Register Name: **TCICE1, TCICE2, TCICE3, TCICE4**
 Register Description: **Transmit Channel Idle Code Enable Registers**
 Register Address: **150H, 151H, 152H, 153H + (200h x n): where n = 0 to 7, for Ports 1 to 8**

(MSB)							(LSB)	
CH8	CH7	CH6	CH5	CH4	CH3	CH2	CH1	TCICE1
CH16	CH15	CH14	CH13	CH12	CH11	CH10	CH9	TCICE2
CH24	CH23	CH22	CH21	CH20	CH19	CH18	CH17	TCICE3
CH32	CH31	CH30	CH29	CH28	CH27	CH26	CH25	TCICE4

The Transmit Channel Idle Code Enable Registers (TCICE1:2:3:4) are used to determine which of the 24 T1 channels (or 32 E1 Channels) from the backplane should be overwritten with the code placed in the Transmit Idle Code Definition Register.

Bits 7 to 0 : Transmit Channels 1 to 32 Code Insertion Control Bits (CH1 to CH32)

0 = do not insert data from the Idle Code Array into the transmit data stream

1 = insert data from the Idle Code Array into the transmit data stream

Register Name: **TFRID**
 Register Description: **Transmit Firmware Revision ID Register**
 Register Address: **161H + (200h x n): where n = 0 to 7, for Ports 1 to 8**

Bit #	7	6	5	4	3	2	1	0
Name	FR7	FR6	FR5	FR4	FR3	FR2	FR1	FR0
Default	0	0	0	0	0	0	0	0

Bits 7 to 0 : Firmware Revision (FR0-FR7). This read-only register reports the transmitter firmware revision.

Register Name: **T1TFDL**
 Register Description: **Transmit FDL Register**
 Register Address: **162H + (200h x n): where n = 0 to 7, for Ports 1 to 8**

Bit #	7	6	5	4	3	2	1	0
Name	CH8	CH7	CH6	CH5	CH4	CH3	CH2	CH1
Default	0	0	0	0	0	0	0	0

[also used to insert Fs framing pattern in D4 framing mode]

The Transmit FDL Register (TFDL) contains the Facility Data Link (FDL) information that is to be inserted on a byte basis into the outgoing T1 data stream. The LSB is transmitted first. In D4 mode, only the lower six bits are used.

Bit 7 : Transmit FDL Bit 7 (TFDL7). MSB of the Transmit FDL Code.

Bit 6 : Transmit FDL Bit 6 (TFDL6).

Bit 5 : Transmit FDL Bit 5 (TFDL5).

Bit 4 : Transmit FDL Bit 4 (TFDL4).

Bit 3 : Transmit FDL Bit 3 (TFDL3).

Bit 2 : Transmit FDL Bit 2 (TFDL2).

Bit 1 : Transmit FDL Bit 1 (TFDL1).

Bit 0 : Transmit FDL Bit 0 (TFDL0). LSB of the Transmit FDL Code.

Register Name: **T1TBOC**
 Register Description: **Transmit BOC Register**
 Register Address: **163H + (200h x n): where n = 0 to 7, for Ports 1 to 8**

Bit #	7	6	5	4	3	2	1	0
Name	-	-	TBOC5	TBOC4	TBOC3	TBOC2	TBOC1	TBOC0
Default	0	0	0	0	0	0	0	0

Bit 5 : Transmit BOC Bit 5 (TBOC5). MSB of the Transmit BOC Code.

Bit 4 : Transmit BOC Bit 4 (TBOC4).

Bit 3 : Transmit BOC Bit 3 (TBOC3).

Bit 2 : Transmit BOC Bit 2 (TBOC2).

Bit 1 : Transmit BOC Bit 1 (TBOC1).

Bit 0 : Transmit BOC Bit 0 (TBOC0). LSB of the Transmit BOC Code.

Register Name: **T1TSLC1, T1TSLC2, T1TSLC3**
 Register Description: **Transmit SLC96 Data Link Registers**
 Register Address: **164H, 165H, 166H + (200h x n): where n = 0 to 7, for Ports 1 to 8**

(MSB)							(LSB)	
C8	C7	C6	C5	C4	C3	C2	C1	T1TSLC1
M2	M1	S=0	S=1	S=0	C11	C10	C9	T1TSLC2
S=1	S4	S3	S2	S1	A2	A1	M3	T1TSLC3

Register Name: **E1TAF**
 Register Description: **Transmit Align Frame Register**
 Register Address: **164H + (200h x n): where n = 0 to 7, for Ports 1 to 8**

Bit #	7	6	5	4	3	2	1	0
Name	Si	0	0	1	1	0	1	1
Default	0	0	0	1	1	0	1	1

Bit 7 : International Bit (Si).

Bit 6 : Frame Alignment Signal Bit (0).

Bit 5 : Frame Alignment Signal Bit (0).

Bit 4 : Frame Alignment Signal Bit (1).

Bit 3 : Frame Alignment Signal Bit (1).

Bit 2 : Frame Alignment Signal Bit (0).

Bit 1 : Frame Alignment Signal Bit (1).

Bit 0 : Frame Alignment Signal Bit (1).

Register Name: **E1TNAF**
 Register Description: **Transmit Non-Align Frame Register**
 Register Address: **165H + (200h x n): where n = 0 to 7, for Ports 1 to 8**

Bit #	7	6	5	4	3	2	1	0
Name	Si	1	A	Sa4	Sa5	Sa6	Sa7	Sa8
Default	0	1	0	0	0	0	0	0

Bit 7 : International Bit (Si).

Bit 6 : Frame Non-Alignment Signal Bit (1).

Bit 5 : Remote Alarm (Used to Transmit the Alarm (A)).

Bit 4 : Additional Bit 4 (Sa4).

Bit 3 : Additional Bit 5 (Sa5).

Bit 2 : Additional Bit 6 (Sa6).

Bit 1 : Additional Bit 7 (Sa7).

Bit 0 : Additional Bit 8 (Sa8).

Register Name: **E1TSiAF**
 Register Description: **Transmit Si Bits of the Align Frame**
 Register Address: **166H + (200h x n): where n = 0 to 7, for Ports 1 to 8**

Bit #	7	6	5	4	3	2	1	0
Name	TSiF14	TSiF12	TSiF10	TSiF8	TSiF6	TSiF4	TSiF2	TSiF0
Default	0	0	0	0	0	0	0	0

Bit 7 : Si Bit of Frame 14 (TSiF14).

Bit 6 : Si Bit of Frame 12 (TSiF12).

Bit 5 : Si Bit of Frame 10 (TSiF10).

Bit 4 : Si Bit of Frame 8 (TSiF8).

Bit 3 : Si Bit of Frame 6 (TSiF6).

Bit 2 : Si Bit of Frame 4 (TSiF4).

Bit 1 : Si Bit of Frame 2 (TSiF2).

Bit 0 : Si Bit of Frame 0 (TSiF0).

Register Name: **E1TSiNAF**
 Register Description: **Transmit Si Bits of the Non-Align Frame**
 Register Address: **167H + (200h x n): where n = 0 to 7, for Ports 1 to 8**

Bit #	7	6	5	4	3	2	1	0
Name	TSiF15	TSiF13	TSiF11	TSiF9	TSiF7	TSiF5	TSiF3	TSiF1
Default	0	0	0	0	0	0	0	0

Bit 7 : Si Bit of Frame 15 (TSiF15).

Bit 6 : Si Bit of Frame 13 (TSiF13).

Bit 5 : Si Bit of Frame 11 (TSiF11).

Bit 4 : Si Bit of Frame 9 (TSiF9).

Bit 3 : Si Bit of Frame 7 (TSiF7).

Bit 2 : Si Bit of Frame 5 (TSiF5).

Bit 1 : Si Bit of Frame 3 (TSiF3).

Bit 0 : Si Bit of Frame 1 (TSiF1).

Register Name: **E1TRA**
 Register Description: **Transmit Remote Alarm**
 Register Address: **168H + (200h x n): where n = 0 to 7, for Ports 1 to 8**

Bit #	7	6	5	4	3	2	1	0
Name	TRAF15	TRAF13	TRAF11	TRAF9	TRAF7	TRAF5	TRAF3	TRAF1
Default	0	0	0	0	0	0	0	0

Bit 7 : Remote Alarm Bit of Frame 15 (TRAF15).

Bit 6 : Remote Alarm Bit of Frame 13 (TRAF13).

Bit 5 : Remote Alarm Bit of Frame 11 (TRAF11).

Bit 4 : Remote Alarm Bit of Frame 9 (TRAF9).

Bit 3 : Remote Alarm Bit of Frame 7 (TRAF7).

Bit 2 : Remote Alarm Bit of Frame 5 (TRAF5).

Bit 1 : Remote Alarm Bit of Frame 3 (TRAF3).

Bit 0 : Remote Alarm Bit of Frame 1 (TRAF1).

Register Name: **E1TSa4**
 Register Description: **Transmit Sa4 Bits**
 Register Address: **169H + (200h x n): where n = 0 to 7, for Ports 1 to 8**

Bit #	7	6	5	4	3	2	1	0
Name	TSa4F15	TSa4F13	TSa4F11	TSa4F9	TSa4F7	TSa4F5	TSa4F3	TSa4F1
Default	0	0	0	0	0	0	0	0

Bit 7 : Sa4 Bit of Frame 15 (TSa4F15).

Bit 6 : Sa4 Bit of Frame 13 (TSa4F13).

Bit 5 : Sa4 Bit of Frame 11 (TSa4F11).

Bit 4 : Sa4 Bit of Frame 9 (TSa4F9).

Bit 3 : Sa4 Bit of Frame 7 (TSa4F7).

Bit 2 : Sa4 Bit of Frame 5 (TSa4F5).

Bit 1 : Sa4 Bit of Frame 3 (TSa4F3).

Bit 0 : Sa4 Bit of Frame 1 (TSa4F1).

Register Name: **E1TSa5**
 Register Description: **Transmitted Sa5 Bits**
 Register Address: **16AH + (200h x n): where n = 0 to 7, for Ports 1 to 8**

Bit #	7	6	5	4	3	2	1	0
Name	TSa5F15	TSa5F13	TSa5F11	TSa5F9	TSa5F7	TSa5F5	TSa5F3	TSa5F1
Default	0	0	0	0	0	0	0	0

Bit 7 : Sa5 Bit of Frame 15 (TSa5F15).

Bit 6 : Sa5 Bit of Frame 13 (TSa5F13).

Bit 5 : Sa5 Bit of Frame 11 (TSa5F11).

Bit 4 : Sa5 Bit of Frame 9 (TSa5F9).

Bit 3 : Sa5 Bit of Frame 7 (TSa5F7).

Bit 2 : Sa5 Bit of Frame 5 (TSa5F5).

Bit 1 : Sa5 Bit of Frame 3 (TSa5F3).

Bit 0 : Sa5 Bit of Frame 1 (TSa5F1).

Register Name: **E1TSa6**
 Register Description: **Transmit Sa6 Bits**
 Register Address: **16BH + (200h x n): where n = 0 to 7, for Ports 1 to 8**

Bit #	7	6	5	4	3	2	1	0
Name	TSa6F15	TSa6F13	TSa6F11	TSa6F9	TSa6F7	TSa6F5	TSa6F3	TSa6F1
Default	0	0	0	0	0	0	0	0

Bit 7 : Sa6 Bit of Frame 15 (TSa6F15).

Bit 6 : Sa6 Bit of Frame 13 (TSa6F13).

Bit 5 : Sa6 Bit of Frame 11 (TSa6F11).

Bit 4 : Sa6 Bit of Frame 9 (TSa6F9).

Bit 3 : Sa6 Bit of Frame 7 (TSa6F7).

Bit 2 : Sa6 Bit of Frame 5 (TSa6F5).

Bit 1 : Sa6 Bit of Frame 3 (TSa6F3).

Bit 0 : Sa6 Bit of Frame 1 (TSa6F1).

Register Name: **E1TSa7**
 Register Description: **Transmit Sa7 Bits**
 Register Address: **16CH + (200h x n): where n = 0 to 7, for Ports 1 to 8**

Bit #	7	6	5	4	3	2	1	0
Name	TSa7F15	TSa7F13	TSa7F11	TSa7F9	TSa7F7	TSa7F5	TSa7F3	TSa7F1
Default	0	0	0	0	0	0	0	0

Bit 7 : Sa7 Bit of Frame 15 (TSa4F15).

Bit 6 : Sa7 Bit of Frame 13 (TSa7F13).

Bit 5 : Sa7 Bit of Frame 11 (TSa7F11).

Bit 4 : Sa7 Bit of Frame 9 (TSa7F9).

Bit 3 : Sa7 Bit of Frame 7 (TSa7F7).

Bit 2 : Sa7 Bit of Frame 5 (TSa7F5).

Bit 1 : Sa7 Bit of Frame 3 (TSa7F3).

Bit 0 : Sa7 Bit of Frame 1 (TSa7F1).

Register Name: **E1TSa8**
 Register Description: **Transmit Sa8 Bits**
 Register Address: **16DH + (200h x n): where n = 0 to 7, for Ports 1 to 8**

Bit #	7	6	5	4	3	2	1	0
Name	TSa8F15	TSa8F13	TSa8F11	TSa8F9	TSa8F7	TSa8F5	TSa8F3	TSa8F1
Default	0	0	0	0	0	0	0	0

Bit 7 : Sa8 Bit of Frame 15 (TSa8F15).

Bit 6 : Sa8 Bit of Frame 13 (TSa8F13).

Bit 5 : Sa8 Bit of Frame 11 (TSa8F11).

Bit 4 : Sa8 Bit of Frame 9 (TSa8F9).

Bit 3 : Sa8 Bit of Frame 7 (TSa8F7).

Bit 2 : Sa8 Bit of Frame 5 (TSa8F5).

Bit 1 : Sa8 Bit of Frame 3 (TSa8F3).

Bit 0 : Sa8 Bit of Frame 1 (TSa8F1).

Register Name: **TMMR**
 Register Description: **Transmit Master Mode Register**
 Register Address: **180H + (200h x n): where n = 0 to 7, for Ports 1 to 8**

Bit #	7	6	5	4	3	2	1	0
Name	FRM_EN	INIT_DONE	-	-	-	-	SFTRST	T1/E1
Default	0	0	0	0	0	0	0	0

Bit 7 : Framer Enable (FRM_EN). This bit must be set to the desired state before writing INIT_DONE.
 0 = Framer disabled – held in low-power state
 1 = Framer enabled – all features active

Bit 6 : Initialization Done (INIT_DONE). The user must set this bit once he has written the configuration registers. The host is required to write or clear all device registers prior to setting this bit. Once INIT_DONE is set, the DS26528 will check the FRM_EN bit and, if enabled will begin operation based on the initial configuration.

Bit 1 : Soft Reset (SFTRST). Level sensitive 'soft' reset. Should be taken high then low to reset the transceiver.
 0 = Normal operation
 1 = Reset the transceiver.

Bit 0 : Transmitter T1/E1 Mode Select (T1/E1). Sets operating mode for transmitter only! This bit must be written with the desired value prior to setting INIT_DONE.
 0 = T1 operation
 1 = E1 operation

Register Name: **TCR1 – T1 Mode**
 Register Description: **Transmit Control Register 1**
 Register Address: **181H + (200h x n): where n = 0 to 7, for Ports 1 to 8**

Bit #	7	6	5	4	3	2	1	0
Name	TJC	TFPT	TCPT	TSSE	GB7S	TB8ZS	TAIS	TRAI
Default	0	0	0	0	0	0	0	0

Bit 7 : Transmit Japanese CRC6 Enable (TJC).

0 = use ANSI/AT&T:ITU CRC6 calculation (normal operation)
 1 = use Japanese standard JT–G704 CRC6 calculation

Bit 6 : Transmit F–Bit Pass Through (TFPT).

0 = F bits sourced internally
 1 = F bits sampled at TSER

Bit 5 : Transmit CRC Pass Through (TCPT).

0 = source CRC6 bits internally
 1 = CRC6 bits sampled at TSER during F–bit time

Bit 4 : Transmit Software Signaling Enable (TSSE). This function is enabled by TB7ZS (TCR2.0).

0 = do not source signaling data from the TSx registers regardless of the SSIEx registers. The SSIEx registers still define which channels are to have B7 stuffing performed.
 1 = source signaling data as enabled by the SSIEx registers.

Bit 3 : Global Bit 7 Stuffing (GB7S). This function is enabled by TB7ZS (TCR2.0).

0 = allow the SSIEx registers to determine which channels containing all zeros are to be Bit 7 stuffed
 1 = force Bit 7 stuffing in all zero byte channels of that port, regardless of how the SSIEx registers are programmed

Bit 2 : Transmit B8ZS Enable (TB8ZS).

0 = B8ZS disabled
 1 = B8ZS enabled

Bit 1 : Transmit Alarm Indication Signal (TAIS).

0 = transmit data normally
 1 = transmit an unframed all one's code at TPOS and TNEG

Bit 0 : Transmit Remote Alarm Indication (TRAI).

0 = do not transmit Remote Alarm
 1 = transmit Remote Alarm

Register Name: **TCR1 – E1 Mode**
 Register Description: **Transmit Control Register 1**
 Register Address: **181H + (200h x n): where n = 0 to 7, for Ports 1 to 8**

Bit #	7	6	5	4	3	2	1	0
Name	TTPT	T16S	TG802	TSiS	TSA1	THDB3	TAIS	TCRC4
Default	0	0	0	0	0	0	0	0

Bit 7 : Transmit Time Slot 0 Pass Through (TTPT).

0 = FAS bits/Sa bits/Remote Alarm sourced internally from the TAF and TNAF registers
 1 = FAS bits/Sa bits/Remote Alarm sourced from TSER

Bit 6 : Transmit Time Slot 16 Data Select (T16S). See Section [9.9.4](#) on Software Signaling.

0 = time slot 16 determined by the SSIEx and THSCS registers
 1 = source time slot 16 from TS1 to TS16 registers

Bit 5 : Transmit G.802 Enable (TG802). See Section [11.4](#).

0 = do not force TCHBLK high during bit 1 of time slot 26
 1 = force TCHBLK high during bit 1 of time slot 26

Bit 4 : Transmit International Bit Select (TSiS).

0 = sample Si bits at TSER pin
 1 = source Si bits from TAF and TNAF registers (in this mode, TCR1.7 must be set to 0)

Bit 3 : Transmit Signaling All Ones (TSA1).

0 = normal operation
 1 = force time slot 16 in every frame to all ones

Bit 2 : Transmit HDB3 Enable (THDB3).

0 = HDB3 disabled
 1 = HDB3 enabled

Bit 1 : Transmit AIS (TAIS).

0 = transmit data normally
 1 = transmit an unframed all-ones code at TPOS and TNEG

Bit 0 : Transmit CRC4 Enable (TCRC4).

0 = CRC4 disabled
 1 = CRC4 enabled

Register Name: **TCR2 – T1 Mode**
 Register Description: **Transmit Control Register 2**
 Register Address: **182H + (200h x n): where n = 0 to 7, for Ports 1 to 8**

Bit #	7	6	5	4	3	2	1	0
Name	TFDLS	TSLC96	-	FBCT2	FBCT1	TD4RM	PDE	TB7ZS
Default	0	0	0	0	0	0	0	0

Bit 7 : TFDL Register Select (TFDLS).

0 = source FDL or Fs bits from the internal TFDL register or the SLC-96 data formatter (TCR2.6)
 1 = source FDL or Fs bits from the internal HDLC controller or the TLINK pin

Bit 6 : Transmit SLC-96 (TSLC96). Set this bit to a one in SLC-96 framing applications. Must be set to source the SLC-96 alignment pattern and data from the TSLC1-3 registers. See Section [9.9.4.3](#) for details.

0 = SLC-96 insertion disabled
 1 = SLC-96 insertion enabled

Bit 4 : F Bit Corruption Type 2. (FBCT2). Setting this bit high enables the corruption of one Ft (D4 framing mode) or FPS (ESF framing mode) bit in every 128 Ft or FPS bits as long as the bit remains set.

Bit 3 : F Bit Corruption Type 1. (FBCT1). A low-to-high transition of this bit causes the next three consecutive Ft (D4 framing mode) or FPS (ESF framing mode) bits to be corrupted causing the remote end to experience a loss of synchronization.

Bit 2 : Transmit D4 RAI Select (TD4RM).

0 = zeros in bit 2 of all channels
 1 = a one in the S-bit position of frame 12

Bit 1 : Pulse Density Enforcer Enable (PDE). The framer always examines both the transmit and receive data streams for violations of the following rules which are required by ANSI T1.403: no more than 15 consecutive zeros and at least N ones in each and every time window of $8 \times (N + 1)$ bits where N = 1 through 23. Violations for the transmit and receive data streams are reported in the TLS1.3 and RLS2.7 bits respectively. When this bit is set to one, the DS26528 will force the transmitted stream to meet this requirement no matter the content of the transmitted stream. When running B8ZS, this bit should be set to zero since B8ZS encoded data streams cannot violate the pulse density requirements.

0 = disable transmit pulse density enforcer
 1 = enable transmit pulse density enforcer

Bit 0 : Transmit Side Bit 7 Zero Suppression Enable (TB7ZS).

0 = no stuffing occurs
 1 = force bit 7 to a one as determined by the GB7S bit at TCR1.3

Register Name: **TCR2 – E1 Mode**
 Register Description: **Transmit Control Register 2**
 Register Address: **182H + (200h x n); where n = 0 to 7, for Ports 1 to 8**

Bit #	7	6	5	4	3	2	1	0
Name	AEBE	AAIS	ARA	Sa4S	Sa5S	Sa6S	Sa7S	Sa8S
Default	0	0	0	0	0	0	0	0

Bit 7 : Automatic E–Bit Enable (AEBE).

0 = E–bits not automatically set in the transmit direction
 1 = E–bits automatically set in the transmit direction

Bit 6 : Automatic AIS Generation (AAIS).

0 = disabled
 1 = enabled

Bit 5 : Automatic Remote Alarm Generation (ARA).

0 = disabled
 1 = enabled

Bit 4 : Sa4 Bit Select (Sa4S). Set to one to source the Sa4 bit from the TLINK pin; set to zero to not source the Sa4 bit.

Bit 3 : Sa5 Bit Select (Sa5S). Set to one to source the Sa5 bit from the TLINK pin; set to zero to not source the Sa5 bit.

Bit 2 : Sa6 Bit Select (Sa6S). Set to one to source the Sa6 bit from the TLINK pin; set to zero to not source the Sa6 bit

Bit 1 : Sa7 Bit Select (Sa7S). Set to one to source the Sa7 bit from the TLINK pin; set to zero to not source the Sa7 bit.

Bit 0 : Sa8 Bit Select (Sa8S). Set to one to source the Sa8 bit from the TLINK pin; set to zero to not source the Sa8 bit.

Register Name: **TCR3**
 Register Description: **Transmit Control Register 3**
 Register Address: **183H + (200h x n); where n = 0 to 7, for Ports 1 to 8**

Bit #	7	6	5	4	3	2	1	0
Name	ODF	ODM	TCSS1	TCSS0	MFRS	TFM	IBPV	TLOOP
Default	0	0	0	0	0	0	0	0

Bit 7 : Output Data Format (ODF).

0 = bipolar data at TPOS and TNEG
 1 = NRZ data at TPOS; TNEG = 0

Bit 6 : Output Data Mode (ODM).

0 = pulses at TPOS and TNEG are one full TCLK period wide
 1 = pulses at TPOS and TNEG are 1/2 TCLK period wide

Bits 5, 4 : Transmit Clock Source Select 1, 0 (TCSS1/0).

TCSS1	TCSS0	Transmit Clock Source
0	0	The TCLK pin is always the source of Transmit Clock.
0	1	Switch to the clock present at RCLK when the signal at the TCLK pin fails to transition after 1 channel time.
1	0	Reserved
1	1	Use the signal present at RCLK as the Transmit Clock. The TCLK pin is ignored.

Bit 3 : Multiframe Reference Select (MFRS). This bit selects the source for the transmit formatter multiframe boundary.

0 = Normal Operation. Transmit multiframe boundary is determined by 'line-side' counters referenced to TSYNC when TSYNC is an input. Free-running when TSYNC is an output.
 1 = Pass-Forward Operation. Tx multiframe boundary determined by 'system-side' counters referenced to TSSYNClO(input mode3), which is then 'passed forward' to the line side clock domain. This mode can only be used when the transmit elastic store is enabled with a synchronous backplane (ie: no frame slips allowed). This mode must be used to allow Tx hardware signaling insertion while the Tx elastic store is enabled.

Bit 2 : Transmit Frame Mode Select (TFM). T1 Mode Only

0 = ESF framing mode
 1 = D4 framing mode

Bit 1 : Insert BPV (IBPV). A 0-to-1 transition on this bit will cause a single BiPolar Violation (BPV) to be inserted into the transmit data stream. Once this bit has been toggled from a 0 to a 1, the device waits for the next occurrence of three consecutive ones to insert the BPV. This bit must be cleared and set again for a subsequent error to be inserted.

Bit 0 (T1 Mode): Transmit Loop Code Enable (TLOOP). See Section [9.9.15](#) for details.

0 = transmit data normally
 1 = replace normal transmitted data with repeating code as defined in registers TCD1 and TCD2

Bit 0 (E1 Mode) : CRC-4 Recalculate (CRC4R).

0 = transmit CRC-4 generation and insertion operates in normal mode
 1 = transmit CRC-4 generation operates according to G.706 Intermediate Path Recalculation method.

Register Name: **TIOCR**
 Register Description: **Transmit I/O Configuration Register**
 Register Address: **184H + (200h x n); where n = 0 to 7, for Ports 1 to 8**

Bit #	7	6	5	4	3	2	1	0
Name	TCLKINV	TSYNCINV	TSSYNCINV	TSCLKM	TSSM	TSIO	TSDW	TSM
Default	0	0	0	0	0	0	0	0

Bit 7 : TCLK Invert (TCLKINV).

0 = No inversion
 1 = Invert

Bit 6 : TSYNC Invert (TSYNCINV).

0 = No inversion
 1 = Invert

Bit 5 : TSSYNCIO(Input Mode Only) Invert (TSSYNCINV).

0 = No inversion
 1 = Invert

Bit 4 : TSYCLK Mode Select (TSCLKM).

0 = if TSYCLK is 1.544MHz
 1 = if TSYCLK is 2.048/4.096/8.192MHz or IBO enabled (see Section [9.8.2](#) for details on IBO function)

Bit 3 : TSSYNCIO Mode Select (TSSM). Selects frame or multiframe mode for the TSSYNCIO pin.

0 = frame mode
 1 = multiframe mode

Bit 2 : TSYNC I/O Select (TSIO).

0 = TSYNC is an input
 1 = TSYNC is an output

Bit 1 : TSYNC Double-Wide (TSDW). (Note: this bit must be set to zero when TSM = 1 or when TSIO = 0)

0 = do not pulse double-wide in signaling frames
 1 = do pulse double-wide in signaling frames

Bit 0 : TSYNC Mode Select (TSM). Selects frame or multiframe mode for the TSYNC pin.

0 = frame mode
 1 = multiframe mode

Register Name: **TESCR**
 Register Description: **Transmit Elastic Store Control Register**
 Register Address: **185H + (200h x n): where n = 0 to 7, for Ports 1 to 8**

Bit #	7	6	5	4	3	2	1	0
Name	TDATFMT	TGCLKEN	--	TSZS	TESALGN	TESR	TESMDM	TESE
Default	0	0	0	0	0	0	0	0

Bit 7 : Transmit Channel Data Format (TDATFMT).

- 0 = 64kBps (data contained in all 8 bits)
- 1 = 56kBps (data contained in 7 out of the 8 bits)

Bit 6 : Transmit Gapped Clock Enable (TGPKEN).

- 0 = TCHCLK functions normally
- 1 = Enable gapped bit clock output on TCHCLK

Note: Bits 6 and 7 are used for fractional backplane support. See Section [9.8.5](#).

Bit 5 : Reserved, must be set to zero for proper operation.

Bit 4 : Transmit Slip Zone Select (TSZS). This bit determines the minimum distance allowed between the elastic store read and write pointers before forcing a controlled slip. This bit is only applies during T1 to E1 or E1 to T1 conversion applications.

- 0 = force a slip at 9 bytes or less of separation (used for clustered blank channels)
- 1 = force a slip at 2 bytes or less of separation (used for distributed blank channels)

Bit 3 : Transmit Elastic Store Align (TESALGN). Setting this bit from a zero to a one will force the transmit elastic store's write/read pointers to a minimum separation of half a frame. No action will be taken if the pointer separation is already greater or equal to half a frame. If pointer separation is less than half a frame, the command will be executed and the data will be disrupted. Should be toggled after TSYCLK has been applied and is stable. Must be cleared and set again for a subsequent align.

Bit 2 : Transmit Elastic Store Reset (TESR). Setting this bit from a zero to a one will force the read pointer into the same frame that the write pointer is exiting, minimizing the delay through the elastic store. If this command should place the pointers within the slip zone (see bit 4), then an immediate slip will occur and the pointers will move back to opposite frames. Should be toggled after TSYCLK has been applied and is stable. Do not leave this bit set HIGH.

Bit 1 : Transmit Elastic Store Minimum Delay Mode (TESMDM).

- 0 = elastic stores operate at full two frame depth
- 1 = elastic stores operate at 32-bit depth

Bit 0 : Transmit Elastic Store Enable (TESE).

- 0 = elastic store is bypassed
- 1 = elastic store is enabled

Register Name: **TCR4 — T1 Mode Only**
 Register Description: **Transmit Control Register 4**
 Register Address: **186H + (200h x n): where n = 0 to 7, for Ports 1 to 8**

Bit #	7	6	5	4	3	2	1	0
Name	-	-	-	-	TRAIM	TAISM	TC1	TC0
Default	0	0	0	0	0	0	0	0

Bits 3 : Transmit RAI Mode (TRAIM). Determines the pattern sent when TRAI (TCR1.0) is activated in ESF frame mode only.

- 0 = transmit normal RAI upon activation with TCR1.0
- 1 = transmit RAI-CI (T1.403) upon activation with TCR1.0

Bits 2 : Transmit AIS Mode (TAISM). Determines the pattern sent when TAIS (TCR1.1) is activated.

- 0 = transmit normal AIS (unframed all ones) upon activation with TCR1.1
- 1 = transmit AIS-CI (T1.403) upon activation with TCR1.1

Bits 1, 0 : Transmit Code Length Definition Bits (TC[1:0]).

TC1	TC0	Length Selected
0	0	5 bits
0	1	6 bits : 3 bits
1	0	7 bits
1	1	16 bits : 8 bits : 4 bits : 2 bits : 1 bit

Register Name: **THFC**
 Register Description: **Transmit HDLC FIFO Control Register**
 Register Address: **187H + (200h x n): where n = 0 to 7, for Ports 1 to 8**

Bit #	7	6	5	4	3	2	1	0
Name	-	-	-	-	-	-	TFLWM1	TFLWM2
Default	0	0	0	0	0	0	0	0

Bits 1, 0 : Transmit HDLC FIFO Low Watermark Select (TFLWM[1:0]).

TFLWM1	TFLWM0	Transmit FIFO Watermark
0	0	4 bytes
0	1	16 bytes
1	0	32 bytes
1	1	48 bytes

Register Name: **TIBOC**
 Register Description: **Transmit Interleave Bus Operation Control Register**
 Register Address: **188H + (200h x n): where n = 0 to 7, for Ports 1 to 8**

Bit #	7	6	5	4	3	2	1	0
Name	-	IBS1	IBS0	IBOSEL	IBOEN	DA2	DA1	DA0
Default	0	0	0	0	0	0	0	0

Bit 7 : Unused, must be set to zero for proper operation.

Bits 6, 5 : IBO Bus Size (IBS[1:0]). Indicates how many devices on the bus.

IBS1	IBS0	Bus Size
0	0	2 Devices on bus
0	1	4 Devices on bus
1	0	8 Devices on bus
1	1	Reserved for future use

Bit 4 : Interleave Bus Operation Select (IBOSEL). This bit selects channel or frame interleave mode.

0 = Channel Interleave

1 = Frame Interleave

Bit 3 : Interleave Bus Operation Enable (IBOEN).

0 = Interleave Bus Operation disabled.

1 = Interleave Bus Operation enabled.

Bits 2 to 0 : Device Assignment bits (DA[2:0]).

DA2	DA1	DA0	Device Position
0	0	0	1st Device on bus
0	0	1	2nd Device on bus
0	1	0	3rd Device on bus
0	1	1	4th Device on bus
1	0	0	5th Device on bus
1	0	1	6th Device on bus
1	1	0	7th Device on bus
1	1	1	8th Device on bus

Register Name: **TDS0SEL**
 Register Description: **Transmit DS0 Channel Monitor Select**
 Register Address: **189H + (200h x n): where n = 0 to 7, for Ports 1 to 8**

Bit #	7	6	5	4	3	2	1	0
Name	-	-	-	TCM4	TCM3	TCM2	TCM1	TCM0
Default	0	0	0	0	0	0	0	0

Bits 7 to 5 : Unused, must be set to zero for proper operation

Bits 4 to 0 : Transmit Channel Monitor Bits (TCM[4:0]). TCM0 is the LSB of a 5 bit channel select that determines which transmit channel data will appear in the TDS0M register. Channels 1 through 32 are represented by a 5-bit BCD code from 0 to 31. TCM0 to TCM4 = all 0s selects channel 1, TCM 0 to TCM 4 = 11111 selects channel 32.

Register Name: **TXPC**
 Register Description: **Transmit Expansion Port Control Register**
 Register Address: **18AH + (200h x n): where n = 0 to 7, for Ports 1 to 8**

Bit #	7	6	5	4	3	2	1	0
Name	--	--	--	--	--	TBPDIR	TBPFUS	TBPEN
Default	0	0	0	0	0	0	0	0

Bit 2 : Transmit BERT Port Direction Control (TBPDIR).

0 = Normal (line) operation. Tx BERT port sources data into the transmit path.

1 = System (Backplane) operation. Tx BERT port sources data into the transmit path (RDATA). In this mode the data on TBPDATA is muxed into the receive path at RDATA (the line side of the e-store). The clock on TBPCLK becomes the clock that was generated for RBPCLK, referenced to RCLK.

Bit 1 : Transmit BERT Port Framed/Unframed Select (TBPFUS).

0 = The DS26528's TBP_CLK will not clock data into the F-bit position (framed)

1 = The DS26528's TBP_CLK will clock data into the F-bit position (unframed)

Bit 0 : Transmit BERT Port Enable (TBPEN).

0 = Transmit BERT Port is not active

1 = Transmit BERT Port is active.

Register Name: **TBPBS**
 Register Description: **Transmit BERT Port Bit Suppress Register**
 Register Address: **18BH + (200h x n): where n = 0 to 7, for Ports 1 to 8**

Bit #	7	6	5	4	3	2	1	0
Name	BPBSE8	BPBSE7	BPBSE6	BPBSE5	BPBSE4	BPBSE3	BPBSE2	BPBSE1
Default	0	0	0	0	0	0	0	0

Bit 7 : Transmit Channel Bit 8 Suppress (BSE8). MSB of the channel. Set to one to stop this bit from being used.

Bit 6 : Transmit Channel Bit 7 Suppress (BSE7). Set to one to stop this bit from being used.

Bit 5 : Transmit Channel Bit 6 Suppress (BSE6). Set to one to stop this bit from being used.

Bit 4 : Transmit Channel Bit 5 Suppress (BSE5). Set to one to stop this bit from being used

Bit 3 : Transmit Channel Bit 4 Suppress (BSE4). Set to one to stop this bit from being used

Bit 2 : Transmit Channel Bit 3 Suppress (BSE3). Set to one to stop this bit from being used

Bit 1 : Transmit Channel Bit 2 Suppress (BSE2). Set to one to stop this bit from being used

Bit 0 : Transmit Channel Bit 1 Suppress (BSE1). LSB of the channel. Set to one to stop this bit from being used.

Register Name: **TSYNCC**
 Register Description: **Transmit Synchronizer Control Register**
 Register Address: **18EH + (200h x n): where n = 0 to 7, for Ports 1 to 8**

Bit #	7	6	5	4	3	2	1	0
Name	-	-	-	-	CRC4	TSEN	SYNCE	RESYNC
Default	0	0	0	0	0	0	0	0

Bit 3 : CRC4 Enable (RCRC4). E1 Mode Only

0 = Do not search for the CRC4 multiframe word

1 = Search for the CRC4 multiframe word

Bit 2 : Transmit Synchronizer Enable (TSEN).

0 = Transmit Synchronizer Disabled

1 = Transmit Synchronizer Enabled

Bit 1 : Sync Enable (SYNCE).

0 = auto resync enabled

1 = auto resync disabled

Bit 0 : Resynchronize (RESYNC). When toggled from low to high, a resynchronization of the transmit side framer is initiated. Must be cleared and set again for a subsequent resync.

Register Name: **TLS1**
 Register Description: **Transmit Latched Status Register 1**
 Register Address: **190H + (200h x n): where n = 0 to 7, for Ports 1 to 8**

Bit #	7	6	5	4	3	2	1	0
Name	TESF	TESEM	TSLIP	TSLC96	TPDV	TMF TAF	LOTCC	LOTCC
Default	0	0	0	0	0	0	0	0

Note: All bits in this register are latched and can cause interrupts.

Bit 7 : Transmit Elastic Store Full Event (TESF). Set when the transmit elastic store buffer fills and a frame is deleted.

Bit 6 : Transmit Elastic Store Empty Event (TESEM). Set when the transmit elastic store buffer empties and a frame is repeated.

Bit 5 : Transmit Elastic Store Slip Occurrence Event (TSLIP). Set when the transmit elastic store has either repeated or deleted a frame.

Bit 4 : Transmit SLC-96 Multiframe Event (TSLC96). T1 Mode Only. When enabled by TCR2.6, this bit will set once per SLC-96 multiframe (72 frames) to alert the host that new data may be written to the TSLC1-TSLC3 registers. See Section [9.9.4.3](#) for more information.

Bit 3 (T1 Mode): Transmit Pulse Density Violation Event (TPDV). Set when the transmit data stream does not meet the ANSI T1.403 requirements for pulse density.

Bit 3 (E1 Mode) : Transmit Align Frame Event (TAF). Set every 250 μ s to alert the host that the TAF and TNAF registers need to be updated.

Bit 2 : Transmit Multiframe Event (TMF). In T1 mode, this bit is set every 1.5ms on D4 MF boundaries or every 3ms on ESF MF boundaries. In E1 operation, this bit is set every 2ms (regardless if CRC4 is enabled) on transmit multiframe boundaries. Used to alert the host that signaling data needs to be updated.

Bit 1 : Loss of Transmit Clock Condition Clear (LOTCC). Set when the LOTC condition has cleared (a clock has been sensed at the TCLK pin).

Bit 0 : Loss of Transmit Clock Condition (LOTCC). Set when the TCLK pin has not transitioned for approximately 3 clock periods. Will force the LOTC pin high if enabled. This bit can be cleared by the host even if the condition is still present. The LOTC pin will remain high while the condition exists, even if the host has cleared the status bit. If enabled by TIM1.0, the INTB pin will transition low when this bit is set, and transition high when this bit is cleared (if no other unmasked interrupt conditions exist).

Register Name: **TLS2**
 Register Description: **Transmit Latched Status Register 2 (HDLC)**
 Register Address: **191H + (200h x n); where n = 0 to 7, for Ports 1 to 8**

Bit #	7	6	5	4	3	2	1	0
Name	-	-	-	TFDLE	TUDR	TMEND	TLWMS	TNFS
Default	0	0	0	0	0	0	0	0

Note: All bits in this register are latched and can create interrupts.

Bit 4 : Transmit FDL Register Empty (TFDLE). T1 Mode Only. Set when the TFDL register has shifted out all 8 bits. Useful if the user wants to manually use the TFDL register to send messages, instead of using the HDLC or BOC controller circuits.

Bit 3 : Transmit FIFO Underrun Event (TUDR). Set when the transmit FIFO empties out without having seen the TMEND bit set. An abort is automatically sent.

Bit 2 : Transmit Message End Event (TMEND). Set when the transmit HDLC controller has finished sending a message.

Bit 1 : Transmit FIFO Below Low Watermark Set Condition (TLWMS). Set when the transmit 64-byte FIFO empties beyond the low watermark as defined by the Transmit Low Watermark Bits (TLWM), (Rising edge detect of TLWM).

Bit 0 : Transmit FIFO Not Full Set Condition (TNFS). Set when the transmit 64-byte FIFO has at least one empty byte available for write. Rising edge detect of TNF. Indicates change of state from full to not full.

Register Name: **TLS3**
 Register Description: **Transmit Latched Status Register 3 (Synchronizer)**
 Register Address: **192H + (200h x n); where n = 0 to 7, for Ports 1 to 8**

Bit #	7	6	5	4	3	2	1	0
Name	-	-	-	-	-	-	LOF	LOFD
Default	0	0	0	0	0	0	0	0

Some bits in this register are latched and can create interrupts.

Bit 1 : Loss of Frame (LOF). A real-time bit that indicates that the transmit synchronizer is searching for the sync pattern in the incoming data stream.

Bit 0 : Loss Of Frame Synchronization Detect (LOFD). This latched bit is set when the transmit synchronizer is searching for the sync pattern in the incoming data stream.

Register Name: **TIIR**
 Register Description: **Transmit Interrupt Information Register**
 Register Address: **19FH + (200h x n): where n = 0 to 7, for Ports 1 to 8**

Bit #	7	6	5	4	3	2	1	0
Name	-	-	-	-	-	TLS3	TLS2	TLS1
Default	0	0	0	0	0	0	0	0

The interrupt information register provides an indication of which status registers are generating an interrupt. When an interrupt occurs, the host can read TIIR to quickly identify which of the transmit status registers are causing the interrupt(s). These are real-time registers in that the bits will clear once the appropriate interrupt has been serviced and cleared.

Bit 2 : Transmit Latched Status Register 3 Interrupt Status (TLS3).

0 = No interrupt pending
 1 = Interrupt pending

Bit 1 : Transmit Latched Status Register 2 Interrupt Status (TLS2).

0 = No interrupt pending
 1 = Interrupt pending

Bit 0 : Transmit Latched Status Register 1 Interrupt Status (TLS1).

0 = No interrupt pending
 1 = Interrupt pending

Register Name: **TIM1**
 Register Description: **Transmit Interrupt Mask Register 1**
 Register Address: **1A0H + (200h x n): where n = 0 to 7, for Ports 1 to 8**

Bit #	7	6	5	4	3	2	1	0
Name	TESF	TESEM	TSLIP	TSLC96	TPDV TAF	TMF	LOTCC	LOTCC
Default	0	0	0	0	0	0	0	0

Bit 7 : Transmit Elastic Store Full Event (TESF).

0 = interrupt masked
 1 = interrupt enabled

Bit 6 : Transmit Elastic Store Empty Event (TESEM).

0 = interrupt masked
 1 = interrupt enabled

Bit 5 : Transmit Elastic Store Slip Occurrence Event (TSLIP).

0 = interrupt masked
 1 = interrupt enabled

Bit 4 : Transmit SLC96 Multiframe Event (TSLC96). T1 Mode Only.

0 = interrupt masked
 1 = interrupt enabled

Bit 3 (T1 Mode): Transmit Pulse Density Violation Event (TPDV).

0 = interrupt masked
 1 = interrupt enabled

Bit 3 (E1 Mode): Transmit Align Frame Event (TAF).

0 = interrupt masked
 1 = interrupt enabled

Bit 2 : Transmit Multiframe Event (TMF).

0 = interrupt masked
 1 = interrupt enabled

Bit 1 : Loss of Transmit Clock Clear Condition (LOTCC).

0 = interrupt masked
 1 = interrupt enabled

Bit 0 : Loss of Transmit Clock Condition (LOTCC).

0 = interrupt masked
 1 = interrupt enabled

Register Name: **TIM2**
 Register Description: **Transmit Interrupt Mask Register 2**
 Register Address: **1A1H + (200h x n): where n = 0 to 7, for Ports 1 to 8**

Bit #	7	6	5	4	3	2	1	0
Name	-	-	-	TFDLE	TUDR	TMEND	TLWMS	TNFS
Default	0	0	0	0	0	0	0	0

Bit 4 : Transmit FDL Register Empty (TFDLE). T1 Mode Only.

0 = interrupt masked
 1 = interrupt enabled

Bit 3 : Transmit FIFO Underrun Event (TUDR).

0 = interrupt masked
 1 = interrupt enabled

Bit 2 : Transmit Message End Event (TMEND).

0 = interrupt masked
 1 = interrupt enabled

Bit 1 : Transmit FIFO Below Low WaterMark Set Condition (TLWMS).

0 = interrupt masked
 1 = interrupt enabled

Bit 0 : Transmit FIFO Not Full Set Condition (TNFS).

0 = interrupt masked
 1 = interrupt enabled

Register Name: **TIM3**
 Register Description: **Transmit Interrupt Mask Register 3 (Synchronizer)**
 Register Address: **1A2H + (200h x n): where n = 0 to 7, for Ports 1 to 8**

Bit #	7	6	5	4	3	2	1	0
Name	-	-	-	-	-	-	-	LOFD
Default	0	0	0	0	0	0	0	0

Bit 0 : Loss Of Frame Synchronization Detect (LOFD).

0 = Interrupt Masked
 1 = Interrupt Enabled

Register Name: **T1TCD1**
 Register Description: **Transmit Code Definition Register 1**
 Register Address: **1ACH + (200h x n): where n = 0 to 7, for Ports 1 to 8**

Bit #	7	6	5	4	3	2	1	0
Name	C7	C6	C5	C4	C3	C2	C1	C0
Default	0	0	0	0	0	0	0	0

Bit 7 : Transmit Code Definition Bit 7 (C7). First bit of the repeating pattern.

Bit 6 : Transmit Code Definition Bit 6 (C6).

Bit 5 : Transmit Code Definition Bit 5 (C5).

Bit 4 : Transmit Code Definition Bit 4 (C4).

Bit 3 : Transmit Code Definition Bit 3 (C3).

Bit 2 : Transmit Code Definition Bit 2 (C2). A Don't Care if a 5 bit length is selected.

Bit 1 : Transmit Code Definition Bit 1 (C1). A Don't Care if a 5 or 6 bit length is selected.

Bit 0 : Transmit Code Definition Bit 0 (C0). A Don't Care if a 5, 6 or 7 bit length is selected.

Register Name: **T1TCD2**
 Register Description: **Transmit Code Definition Register 2**
 Register Address: **1ADH + (200h x n): where n = 0 to 7, for Ports 1 to 8**

Bit #	7	6	5	4	3	2	1	0
Name	C7	C6	C5	C4	C3	C2	C1	C0
Default	0	0	0	0	0	0	0	0

Bit 7 : Transmit Code Definition Bit 7 (C7). A Don't Care if a 5, 6 or 7 bit length is selected.

Bit 6 : Transmit Code Definition Bit 6 (C6). A Don't Care if a 5, 6 or 7 bit length is selected.

Bit 5 : Transmit Code Definition Bit 5 (C5). A Don't Care if a 5, 6 or 7 bit length is selected.

Bit 4 : Transmit Code Definition Bit 4 (C4). A Don't Care if a 5, 6 or 7 bit length is selected.

Bit 3 : Transmit Code Definition Bit 3 (C3). A Don't Care if a 5, 6 or 7 bit length is selected.

Bit 2 : Transmit Code Definition Bit 2 (C2). A Don't Care if a 5, 6 or 7 bit length is selected.

Bit 1 : Transmit Code Definition Bit 1 (C1). A Don't Care if a 5, 6 or 7 bit length is selected.

Bit 0 : Transmit Code Definition Bit 0 (C0). A Don't Care if a 5, 6 or 7 bit length is selected.

Register Name: **TRTS2**
 Register Description: **Transmit Real-Time Status Register 2 (HDLC)**
 Register Address: **1B1H + (200h x n): where n = 0 to 7, for Ports 1 to 8**

Bit #	7	6	5	4	3	2	1	0
Name	-	-	-	-	EMPTY	TFULL	TLWM	TNF
Default	0	0	0	0	0	0	0	0

Note: All bits in this register are real time.

Bit 3 : Transmit FIFO Empty (EMPTY). A real-time bit that is set high when the FIFO is empty.

Bit 2 : Transmit FIFO Full (TFULL). A real-time bit that is set high when the FIFO is full.

Bit 1 : Transmit FIFO Below Low Watermark Condition (TLWM). Set when the transmit 64-byte FIFO empties beyond the low watermark as defined by the Transmit Low Watermark Bits (TLWM).

Bit 0 : Transmit FIFO Not Full Condition (TNF). Set when the transmit 64-byte FIFO has at least one byte available.

Register Name: **TFBA**
 Register Description: **Transmit HDLC FIFO Buffer Available**
 Register Address: **1B3H + (200h x n): where n = 0 to 7, for Ports 1 to 8**

Bit #	7	6	5	4	3	2	1	0
Name	--	TFBA6	TFBA5	TFBA4	TFBA3	TFBA2	TFBA1	TFBA0
Default	0	0	0	0	0	0	0	0

Bits 6 to 0 : Transmit FIFO Bytes Available (TFBA6 to TFBA0). TFBA0 is the LSB.

Register Name: **THF**
 Register Description: **Transmit HDLC FIFO**
 Register Address: **1B4 + (200h x n): where n = 0 to 7, for Ports 1 to 8**

Bit #	7	6	5	4	3	2	1	0
Name	THD7	THD6	THD5	THD4	THD3	THD2	THD1	THD0
Default	0	0	0	0	0	0	0	0

Bit 7 : Transmit HDLC Data Bit 7 (THD7). MSB of a HDLC packet data byte.

Bit 6 : Transmit HDLC Data Bit 6 (THD6).

Bit 5 : Transmit HDLC Data Bit 5 (THD5).

Bit 4 : Transmit HDLC Data Bit 4 (THD4).

Bit 3 : Transmit HDLC Data Bit 3 (THD3).

Bit 2 : Transmit HDLC Data Bit 2 (THD2).

Bit 1 : Transmit HDLC Data Bit 1 (THD1).

Bit 0 : Transmit HDLC Data Bit 0 (THD0). LSB of a HDLC packet data byte.

Register Name: **TDS0M**
 Register Description: **Transmit DS0 Monitor Register**
 Register Address: **1BBH + (200h x n): where n = 0 to 7, for Ports 1 to 8**

Bit #	7	6	5	4	3	2	1	0
Name	B1	B2	B3	B4	B5	B6	B7	B8
Default	0	0	0	0	0	0	0	0

Bits 7 to 0 : Transmit DS0 Channel Bits (B1 to B8). Transmit channel data that has been selected by the Transmit Channel Monitor Select Register. B8 is the LSB of the DS0 channel (last bit to be transmitted).

Register Name: **TBCS1, TBCS2, TBCS3, TBCS4**
 Register Description: **Transmit Blank Channel Select Registers**
 Register Address: **1C0H, 1C1H, 1C2H, 1C3H + (200h x n): where n = 0 to 7, for Ports 1 to 8**

(MSB)							(LSB)	
CH8	CH7	CH6	CH5	CH4	CH3	CH2	CH1	TBCS1
CH16	CH15	CH14	CH13	CH12	CH11	CH10	CH9	TBCS2
CH24	CH23	CH22	CH21	CH20	CH19	CH18	CH17	TBCS3
CH32	CH31	CH30	CH29	CH28	CH27	CH26	CH25	TBCS4

Bits 7 to 0 : Transmit Blank Channel Select for Channels 1 to 32 (TBCS1 to TBCS32).

0 = transmit TSER data from this channel

1 = ignore TSER data from this channel

Note that when two or more sequential channels are chosen to be ignored, the receive slip zone select bit should be set to zero. If the ignore channels are distributed (such as 1, 5, 9, 13, 17, 21, 25, 29) then the RSZS bit can be set to one, which may provide a lower occurrence of slips in certain applications.

Register Name: **TCBR1, TCBR2, TCBR3, TCBR4**
 Register Description: **Transmit Channel Blocking Registers**
 Register Address: **1C4H, 1C5H, 1C6H, 1C7H + (200h x n): where n = 0 to 7, for Ports 1 to 8**

(MSB)							(LSB)	
CH8	CH7	CH6	CH5	CH4	CH3	CH2	CH1	TCBR1
CH16	CH15	CH14	CH13	CH12	CH11	CH10	CH9	TCBR2
CH24	CH23	CH22	CH21	CH20	CH19	CH18	CH17	TCBR3
CH32	CH31	CH30	CH29	CH28	CH27	CH26	CH25: Fbit	TCBR4*

Bits 7 to 0 : Transmit Channels 1 to 32 Channel Blocking Control Bits (CH1 to CH32).

0 = force the TCHBLK pin to remain low during this channel time

1 = force the TCHBLK pin high during this channel time

*** Note that TCBR4 has two functions:**

When 2.048MHz backplane mode is selected, this register allows the user to enable the channel blocking signal for any of the 32 possible backplane channels.

When 1.544MHz backplane mode is selected, the LSB of this register determines whether or not the TCHBLK signal will pulse high during the F-Bit time:

TCBR4.0 = 0, do not pulse TCHBLK during the F-Bit

TCBR4.0 = 1, pulse TCHBLK during the F-Bit

In this mode TCBR4.1 to TCBR4.7 should be set to '0'.

Register Name: **THSCS1, THSCS2, THSCS3, THSCS4**
 Register Description: **Transmit Hardware Signaling Channel Select Registers**
 Register Address: **1C8H, 1C9H, 1CAH, 1CBH + (200h x n): where n = 0 to 7, for Ports 1 to 8**

(MSB)							(LSB)	
CH8	CH7	CH6	CH5	CH4	CH3	CH2	CH1	THSCS1
CH16	CH15	CH14	CH13	CH12	CH11	CH10	CH9	THSCS2
CH24	CH23	CH22	CH21	CH20	CH19	CH18	CH17	THSCS3
CH32	CH31	CH30	CH29	CH28	CH27	CH26	CH25	THSCS4*

Bits 7 to 0 : Transmit Hardware Signaling Channel Select for Channels 1 to 32 (THSCS1 to THSCS4). These bits determine which channels have signaling data inserted from the TSIG pin into the TSER PCM data.

0 = do not source signaling data from the TSIG pin for this channel

1 = source signaling data from the TSIG pin for this channel

* Note that THSCS4 is only used in 2.048MHz backplane applications.

Register Name: **TGCCS1, TGCCS2, TGCCS3, TGCCS4**
 Register Description: **Transmit Gapped Clock Channel Select Registers**
 Register Address: **1CCH, 1CDH, 1CEH, 1CFH + (200h x n): where n = 0 to 7, for Ports 1 to 8**

(MSB)								(LSB)		
CH8	CH7	CH6	CH5	CH4	CH3	CH2	CH1			TGCCS1
CH16	CH15	CH14	CH13	CH12	CH11	CH10	CH9			TGCCS2
CH24	CH23	CH22	CH21	CH20	CH19	CH18	CH17			TGCCS3
CH32	CH31	CH30	CH29	CH28	CH27	CH26	CH25: Fbit			TGCCS4*

Bits 7 to 0 : Transmit Channels 1 to 32 Gapped Clock Channel Select Bits (CH1 to CH32).
 0 = no clock is present on TCHCLK during this channel time
 1 = force a clock on TCHCLK during this channel time. The clock will be synchronous with TCLK if the elastic store is disabled, and synchronous with TSYCLK if the elastic store is enabled.

*** Note that TGCCS4 has two functions:**
 When 2.048MHz backplane mode is selected, this register allows the user to enable the 'gapped' clock on TCHCLK for any of the 32 possible backplane channels.

When 1.544MHz backplane mode is selected, the LSB of this register determines whether or not a clock is generated on TCHCLK during the F-Bit time:
 TGCCS4.0 = 0, do not generate a clock during the F-Bit
 TGCCS4.0 = 1, generate a clock during the F-Bit

In this mode TGCCS4.1 to TGCCS4.7 should be set to '0'.

Register Name: **PCL1, PCL2, PCL3, PCL4**
 Register Description: **Per-Channel Loopback Enable Registers**
 Register Address: **1D0H, 1D1H, 1D2H, 1D3H + (200h x n): where n = 0 to 7, for Ports 1 to 8**

(MSB)								(LSB)		
CH8	CH7	CH6	CH5	CH4	CH3	CH2	CH1			PCL1
CH16	CH15	CH14	CH13	CH12	CH11	CH10	CH9			PCL2
CH24	CH23	CH22	CH21	CH20	CH19	CH18	CH17			PCL3
CH32	CH31	CH30	CH29	CH28	CH27	CH26	CH25			PCL4

Bits 7 to 0 : Per-Channel Loopback Enable for Channels 32 to 1 (CH32 to CH1).
 0 = Loopback disabled
 1 = Enable Loopback. Source data from the corresponding receive channel

Register Name: **TBPCS1, TBPCS2, TBPCS3, TBPCS4**
 Register Description: **Transmit BERT Port Channel Select Registers**
 Register Address: **1D4H, 1D5H, 1D6H, 1D7H + (200h x n): where n = 0 to 7, for Ports 1 to 8**

(MSB)							(LSB)	
CH8	CH7	CH6	CH5	CH4	CH3	CH2	CH1	TBPCS1
CH16	CH15	CH14	CH13	CH12	CH11	CH10	CH9	TBPCS2
CH24	CH23	CH22	CH21	CH20	CH19	CH18	CH17	TBPCS3
CH32	CH31	CH30	CH29	CH28	CH27	CH26	CH25	TBPCS4

Setting any of the CH1 through CH24 bits in the TBPCS1 through TBPCS3 registers will enable the TBP_CLK for the associated channel time, and allow mapping of the selected channel data out of the receive BERT Port. Multiple, or all channels may be selected simultaneously.

10.5 LIU Register Definitions

Table 10-13. LIU Register Set

ADDR	ABBR	DESCRIPTION	R/W
1000	LTRCR	LIU Transmit Receive Control Register	R/W
1001	LTITSR	LIU Transmit Impedance Selection Register	R/W
1002	LMCR	LIU Maintenance Control Register	R/W
1003	LRSR	LIU Real Status Register	R
1004	LSIMR	LIU Status Interrupt Mask Register	R/W
1005	LLSR	LIU Latched Status Register	R/W
1006	LRSL	LIU Receive Signal Level	R
1007	LRISMR	LIU Receive Impedance and Sensitivity Monitor Register	R/W
1008-101F	-	Reserved	-

Note: Reserved registers should only be written with all zeros.

Register Name: **LTRCR**
 Register Description: **LIU Transmit Receive Control Register**
 Register Addresses: **1000H + (20h x n): where n = 0 to 7, for Ports 1 to 8**

Bit #	7	6	5	4	3	2	1	0
Name	--	--	--	JADS	JAPS1	JAPS0	T1J1E1S	LSC
Default	0	0	0	0	0	0	0	0

Bit 4 : Jitter Attenuator Depth Select (JADS).

0 = JA FIFO depth set to 128 bits.

1 = JA FIFO depth set to 32 bits. Use for delay-sensitive applications.

Bit 3, 2 : Jitter Attenuator Position Select 1, 0 (JAPS[1:0]). These bits are used to select the position of the jitter attenuator (JA).

JAPS1	JAPS0	Function
0	0	JA in the receive path
0	1	JA in the transmit path
1	0	JA is not used
1	1	JA is not used

Bit 1 : T1J1E1 Selection (T1J1E1S). This bit configures the LIU for E1 or T1/J1 operation.

0 = E1

1 = T1 or J1

Bit 0 : LOS Criteria Selection (LCS). This bit is used for LIU LOS Selection Criteria.

E1 Mode

0 = G.775.

1 = ETSI (300233).

T1 / J1 Mode

0 = T1.231.

1 = T1.231.

Register Name: **LTITSR**
 Register Description: **LIU Transmit Impedance and Pulse Shape Selection Register**
 Register Address: **1001H + (20h x n); where n = 0 to 7, for Ports 1 to 8**

Bit #	7	6	5	4	3	2	1	0
Name	--	TIMPTOFF	TIMPL1	TIMPL0	--	L2	L1	L0
Default	0	0	0	0	0	0	0	0

Bit 6 : Transmit Impedance Off (TIMPTOFF).

0 = Enable transmit terminating impedance.
 1 = Disable transmit terminating impedance.

Bits 5, 4 : Transmit Load Impedance 1, 0 (TIMPL[1:0]). These bits are used to select the transmit load impedance. These must be set to match the cable impedance. Even if the Internal load impedance is turned off (via TIMPTOFF); the external cable impedance has to be specified for optimum operation. For J1 applications, use 110Ω. See [Table 10-14](#).

Bits 2 to 0 : Line Build-Out Select 2 to 0 (L[2:0]). Used to select the transmit waveshape. The waveshape has a voltage level and load impedance associated with it once the T1/J1 or E1 selection is made by settings in the LTRCR register. See [Table 10-15](#).

Table 10-14. Transmit Load Impedance Selection

TIMPL1	TIMPL0	IMPEDANCE SELECTION
0	0	75Ω
0	1	100Ω
1	0	110Ω
1	1	120Ω

Table 10-15. Transmit Pulse Shape Selection

L2	L1	L0	MODE	IMPEDANCE	NOMINAL VOLTAGE
0	0	0	E1	75Ω	2.37V
0	0	1	E1	120Ω	3.0V

L2	L1	L0	MODE	CABLE LENGTH	MAX ALLOWED CABLE LOSS
0	0	0	T1/J1	DSX-1/0dB CSU, 0ft–133ft ABAM 100Ω	0.6dB
0	0	1	T1/J1	DSX-1, 133ft–266ft ABAM 100Ω	1.2dB
0	1	0	T1/J1	DSX-1, 266ft–399ft ABAM 100Ω	1.8dB
0	1	1	T1/J1	DSX-1, 399ft–533ft ABAM 100Ω	2.4dB
1	0	0	T1/J1	DSX-1, 533ft–655ft ABAM 100Ω	3.0dB
1	0	1	T1/J1	-7.5dB CSU	
1	1	0	T1/J1	-15dB CSU	
1	1	1	T1/J1	-22.5dB CSU	

Register Name: **LMCR**
 Register Description: **LIU Maintenance Control Register**
 Register Address: **1002H + (20h x n): where n = 0 to 7, for Ports 1 to 8**

Bit #	7	6	5	4	3	2	1	0
Name	TAIS	ATAIS	LLB	ALB	RLB	TPDE	RPDE	TE
Default	0	0	0	0	0	0	0	0

Bit 7 : Transmit AIS (TAIS). Alarm Indication Signal (AIS) is sent using MCLK as the reference clock. The transmit data coming from the framer is ignored.

0 = TAIS is disabled.

1 = Output an unframed all ones pattern (AIS) at TTIP and TRING.

Bit 6 : Automatic Transmit AIS (ATAIS).

0 = ATAIS is disabled.

1 = Automatically transmit AIS on the occurrence of a LIU LOS.

Bit 5 : Local Loopback (LLB). See Section [9.11.5.2](#) Local Loopback for operational details.

0 = LLB is disabled.

1 = LLB is enabled.

Bit 4 : Analog Loopback (ALB). See Section [9.11.5.1](#) Analog Loopback for operational details.

0 = ALB is disabled.

1 = ALB is enabled.

Bit 3 : Remote Loopback (RLB). See Section [9.11.5.3](#) Remote Loopback for operational details.

0 = Remote loopback is disabled.

1 = Remote loopback is enabled.

In this loopback, received data passes all the way through the receive LIU and is then transmitted back through the transmit side of the LIU. Data will continue to pass through the receive side framer of the DS26528 as it would normally and the data from the transmit side of the framer will be ignored.

Bit 2 : Transmit Power-Down Enable (TPDE).

0 = Transmitter power enabled.

1 = Transmitter powered down. TIP/RING outputs are High-Z.

Bit 1 : Receiver Power-Down Enable (RPDE).

0 = Receiver power enabled.

1 = Receiver powered down.

Bit 0 : Transmit Enable (TE). This function is overridden by the TXENABLE pin.

0 = TTIP/TRING outputs are High-Z.

1 = TTIP/TRING outputs enabled.

Register Name: **LRSR**
 Register Description: **LIU Real Status Register**
 Register Address: **1003H + (20h x n): where n = 0 to 7, for Ports 1 to 8**

Bit #	7	6	5	4	3	2	1	0
Name	--	--	OEQ	UEQ	--	SCS	OCS	LOSS
Default	0	0	0	0	0	0	0	0

Bit 5 : Over Equalized (OEQ). The equalizer is over equalized. This can happen if there very large unexpected resistive loss. This could result if monitor mode is used and the device is not placed in monitor mode. This indicator provides more qualitative information to the receive loss indicators.

Bit 4 : Under Equalized (UEQ). The equalizer is under equalized. A signal with a very high resistive gain is being applied. This indicator provides more qualitative information to the receive loss indicators.

Bit 2: Short Circuit Status (SCS). A real-time bit set when the LIU detects that the TTIP and TRING outputs are short-circuited. The load resistance has to be 25Ω (typically) or less for short circuit detection.

Bit 1: Open Circuit Status (OCS). A real-time bit set when the LIU detects that the TTIP and TRING outputs are open-circuited.

Bit 0: Loss of Signal Status (LOS). A real-time bit set when the LIU detects a LOS condition at RTIP and RRING.

Register Name: **LSIMR**
 Register Description: **LIU Status Interrupt Mask Register**
 Register Address: **1004H + (20h x n); where n = 0 to 7, for Ports 1 to 8**

Bit #	7	6	5	4	3	2	1	0
Name	JALTCIM	OCCIM	SCCIM	LOSCIM	JALTSIM	OCDIM	SCDIM	LOSDIM
Default	0	0	0	0	0	0	0	0

Bit 7 : Jitter Attenuator Limit Trip Clear Interrupt Mask (JALTCIM).

0 = Interrupt masked.
 1 = Interrupt enabled.

Bit 6 : Open Circuit Clear Interrupt Mask (OCCIM).

0 = Interrupt masked.
 1 = Interrupt enabled.

Bit 5 : Short Circuit Clear Interrupt Mask (SCCIM).

0 = Interrupt masked.
 1 = Interrupt enabled.

Bit 4 : Loss of Signal Clear Interrupt Mask (LOSCIM).

0 = Interrupt masked.
 1 = Interrupt enabled.

Bit 3 : Jitter Attenuator Limit Trip Set Interrupt Mask (JALTSIM).

0 = Interrupt masked.
 1 = Interrupt enabled.

Bit 2 : Open Circuit Detect Interrupt Mask (OCDIM).

0 = Interrupt masked.
 1 = Interrupt enabled.

Bit 1 : Short Circuit Detect Interrupt Mask (SCDIM).

0 = Interrupt masked.
 1 = Interrupt enabled.

Bit 0 : Loss of Signal Detect Interrupt Mask (LOSDIM).

0 = Interrupt masked.
 1 = Interrupt enabled.

Register Name: **LLSR**
 Register Description: **LIU Latched Status Register**
 Register Address: **1005H + (20h x n): where n = 0 to 7, for Ports 1 to 8**

Bit #	7	6	5	4	3	2	1	0
Name	JALTC	OCC	SCC	LOSC	JALTS	OCD	SCD	LOSD
Default	0	0	0	0	0	0	0	0

All bits in this register are latched and can create interrupts.

Bit 7 : Jitter Attenuator Limit Trip Clear (JALTC). This latched bit is set when a JA limit trip condition was detected and then removed.

Bit 6 : Open Circuit Clear (OCC). This latched bit is set when an open circuit condition was detected at TTIP and TRING and then removed.

Bit 5 : Short Circuit Clear (SCC). This latched bit is set when a short circuit condition was detected at TTIP and TRING and then removed.

Bit 4 : Loss of Signal Clear (LOSC). This latched bit is set when a loss of signal condition was detected at RTIP and RRING and then removed.

Bit 3 : Jitter Attenuator Limit Trip Set (JALTS). This latched bit is set when the jitter attenuator trip condition is detected.

Bit 2 : Open Circuit Detect (OCD). This latched bit when set when open circuit condition is detected at TTIP and TRING.

Bit 1 : Short Circuit Detect (SCD). This latched bit is set when short circuit condition is detected at TTIP and TRING.

Bit 0 : Loss of Signal Detect (LOSD). This latched bit is set when LOS condition is detected at RTIP and RRING.

Register Name: **LRSL**
 Register Description: **LIU Receive Signal Level**
 Register Address: **1006H + (20h x n): where n = 0 to 7, for Ports 1 to 8**

Bit #	7	6	5	4	3	2	1	0
Name	RSL3	RSL2	RLS1	RLS0	--	--	--	--
Default	0	0	0	0	0	0	0	0

Bit 7 to 4 : Receiver Signal Level 3 to 0 (RSL[3:0]). Real-time receive signal level as shown in [Table 10-16](#). Note that the range of signal levels reported the RSL0-3 is limited by the Equalizer Gain Limit (EGL) in short-haul applications.

Table 10-16. Receive Level Indication

RSL3	RSL2	RSL1	RSL0	RECEIVE LEVEL (dB)	
				T1	E1
0	0	0	0	>-2.5	>-2.5
0	0	0	1	-2.5 to -5	-2.5 to -5
0	0	1	0	-5 to -7.5	-5 to -7.5
0	0	1	1	-7.5 to -10	-7.5 to -10
0	1	0	0	-10 to -12.5	-10 to -12.5
0	1	0	1	-12.5 to -15	-12.5 to -15
0	1	1	0	-15 to -17.5	-15 to -17.5
0	1	1	1	-17.5 to -20	-17.5 to -20
1	0	0	0	-20 to -23	-20 to -23
1	0	0	1	-23 to -26	-23 to -26
1	0	1	0	-26 to -29	-26 to -29
1	0	1	1	-29 to -32	-29 to -32
1	1	0	0	-32 to -36	-32 to -36
1	1	0	1	<-36	-36 to -40
1	1	1	0		-40 to -44
1	1	1	1		<-44

Register Name: **LRISMR**
 Register Description: **LIU Receive Impedance and Sensitivity Monitor Register**
 Register Address: **1007H + (20h x n): where n = 0 to 7, for Ports 1 to 8**

Bit #	7	6	5	4	3	2	1	0
Name	RG703	RIMPOFF	RIMPM1	RIMPM0	RTR	RMONEN	RSMS1	RSMS0
Default	0	0	0	0	0	0	0	0

Bit 7 : Receive G.703 Clock (RG703). If this bit is set, the receiver expects a 2.048MHz or 1.544MHz clock from the RTIP/RRING, based on the selection of T1 (1.544) or E1 (2.048) mode in the [LTRCR](#) register.

Bit 6 : Receive Impedance Termination Off (RIMPOFF).

0 = Receive terminating impedance match is enabled.

1 = Receive terminating impedance match is disabled.

Bit 5, 4 : Receive Impedance Match 1, 0 (RIMPM[1:0]). These bits are used to select the receive impedance match value. These must be set according to the Cable Impedance. Even if the Internal Receive Match Impedance is turned off (RIMOFF); the external cable impedance has to be specified for optimum operation by RIMPM1 to 0. See [Table 10-17](#).

Bit 3 : Receiver Turns Ratio (RTR).

0 = Receive transformer turns ratio is 1:1.

1 = Receive transformer turns ratio is 2:1. This option should only be used in short haul applications.

Bit 2 : Receiver Monitor Mode Enable (RMONEN).

0 = Disable receive monitor mode.

1 = Enable receive monitor mode. Resistive gain is added with the maximum sensitivity. The receiver sensitivity is determined by RSMS1 and RSMS0

Bit 1, 0 : Receiver Sensitivity / Monitor Gain Select 1, 0 (RSMS[1:0]). These bits are used to select the receiver sensitivity level and additional gain in monitoring applications. The monitor mode (RMONEN) adds resistive gain to compensate for the signal loss caused by the isolation resistors. See [Table 10-18](#) and [Table 10-19](#).

Table 10-17. Receive Impedance Selection

RIMPRM1, RIMPRM0	RECEIVE IMPEDANCE SELECTED (Ω)
00	75
01	100
10	110
11	120

Table 10-18. Receiver Sensitivity Selection with Monitor Mode Disabled

RMONEN	RSMS [1:0]	RECEIVER MONITOR MODE GAIN (dB)	RECEIVER SENSITIVITY (MAX CABLE LOSS ALLOWED) (dB)
0	00	0	12
0	01	0	18
0	10	0	30
0	11	0	36 for T1; 43 for E1

Table 10-19. Receiver Sensitivity Selection with Monitor Mode Enabled

RMONEN	RSMS [1:0]	RECEIVER MONITOR MODE GAIN (dB)	RECEIVER SENSITIVITY (MAX CABLE LOSS ALLOWED) (dB)
1	00	14	30
1	01	20	22.5
1	10	26	17.5
1	11	32	12

10.6 BERT Register Definitions

Table 10-20. BERT Register Set

ADDR	ABBR	DESCRIPTION	R/W
1100	BAWC	BERT Alternating Word Count Rate	R
1101	BRP1	BERT Repetitive Pattern Set Register 1	R/W
1102	BRP2	BERT Repetitive Pattern Set Register 2	R/W
1103	BRP3	BERT Repetitive Pattern Set Register 3	R/W
1104	BRP4	BERT Repetitive Pattern Set Register 4	R/W
1105	BC1	BERT Control Register 1	R/W
1106	BC2	BERT Control Register 2	R/W
1107	BBC1	BERT Bit Count Register 1	R
1108	BBC2	BERT Bit Count Register 2	R
1109	BBC3	BERT Bit Count Register 3	R
110A	BBC4	BERT Bit Count Register 4	R
110B	BEC1	BERT Error Count Register 1	R
110C	BEC2	BERT Error Count Register 2	R
110D	BEC3	BERT Error Count Register 3	R
110E	BLSR	BERT Status Register	R
110F	BSIM	BERT Status Interrupt Mask	R/W

Register Name: **BAWC**
 Register Description: **BERT Alternating Word Count Rate**
 Register Address: **1100H + (10h x n): where n = 0 to 7, for Ports 1 to 8**

Bit #	7	6	5	4	3	2	1	0
Name	ACNT7	ACNT6	ACNT5	ACNT4	ACNT3	ACNT2	ACNT1	ACNT0
Default	0	0	0	0	0	0	0	0

Bits 7 to 0: Alternating Word Count Rate Bits 7 to 0 (ACNT[7:0]). When the BERT is programmed in the alternating word mode, the words will repeat for the count loaded into this register then flip to the other word and again repeat for the number of times loaded into this register. ACNT0 is the LSB of the 8-bit alternating word count rate counter.

Register Name: **BRP1**
 Register Description: **BERT Repetitive Pattern Set Register 1**
 Register Address: **1101H + (10h x n): where n = 0 to 7, for Ports 1 to 8**

Bit #	7	6	5	4	3	2	1	0
Name	RPAT7	RPAT6	RPAT5	RPAT4	RPAT3	RPAT2	RPAT1	RPAT0
Default	0	0	0	0	0	0	0	0

Bits 7 to 0: BERT Repetitive Pattern Set Bits 7 to 0 (RPAT[7:0]). RPAT0 is the LSB of the 32-bit repetitive pattern.

Register Name: **BRP2**
 Register Description: **BERT Repetitive Pattern Set Register 2**
 Register Address: **1102H + (10h x n): where n = 0 to 7, for Ports 1 to 8**

Bit #	7	6	5	4	3	2	1	0
Name	RPAT15	RPAT14	RPAT13	RPAT12	RPAT11	RPAT10	RPAT9	RPAT8
Default	0	0	0	0	0	0	0	0

Bits 7 to 0: BERT Repetitive Pattern Set Bits 15 to 8 (RPAT[15:8]).

Register Name: **BRP3**
 Register Description: **BERT Repetitive Pattern Set Register 3**
 Register Address: **1103H + (10h x n): where n = 0 to 7, for Ports 1 to 8**

Bit #	7	6	5	4	3	2	1	0
Name	RPAT23	RPAT22	RPAT21	RPAT20	RPAT19	RPAT18	RPAT17	RPAT16
Default	0	0	0	0	0	0	0	0

Bits 7 to 0 : BERT Repetitive Pattern Set Bits 23 to 16 (RPAT[23:16]).

Register Name: **BRP4**
 Register Description: **BERT Repetitive Pattern Set Register 4**
 Register Address: **1104H + (10h x n): where n = 0 to 7, for Ports 1 to 8**

Bit #	7	6	5	4	3	2	1	0
Name	RPAT31	RPAT30	RPAT29	RPAT28	RPAT27	RPAT26	RPAT25	RPAT24
Default	0	0	0	0	0	0	0	0

Bits 7 to 0 : BERT Repetitive Pattern Set Bits 31 to 24 (RPAT[31:24]). RPAT31 is the MSB of the 32-bit repetitive pattern.

Register Name: **BC1**
 Register Description: **BERT Control Register 1**
 Register Address: **1105H + (10h x n): where n = 0 to 7, for Ports 1 to 8**

Bit #	7	6	5	4	3	2	1	0
Name	TC	TINV	RINV	PS2	PS1	PS0	LC	RESYNC
Default	0	0	0	0	0	0	0	0

Bit 7: Transmit Pattern Load (TC). A low-to-high transition loads the pattern generator with the pattern that is to be generated. This bit should be toggled from low to high whenever the host wishes to load a new pattern. Must be cleared and set again for a subsequent loads.

Bit 6: Transmit Invert Data Enable (TINV).

0 = do not invert the outgoing data stream
 1 = invert the outgoing data stream

Bit 5: Receive Invert Data Enable (RINV).

0 = do not invert the incoming data stream
 1 = invert the incoming data stream

Bits 4 to 2: Pattern Select Bits 2 to 0 (PS[2:0]). These bits select data pattern used by the transmit and receive circuits. See [Table 10-21](#).

Table 10-21. BERT Pattern Select

PS2	PS1	PS0	PATTERN DEFINITION
0	0	0	Pseudo-Random 2E7-1
0	0	1	Pseudo-Random 2E11-1
0	1	0	Pseudo-Random 2E15-1
0	1	1	Pseudo-Random Pattern QRSS. A $2^{20} - 1$ pattern with 14 consecutive zero restriction.
1	0	0	Repetitive Pattern
1	0	1	Alternating Word Pattern
1	1	0	Modified 55 Octet (Daly) Pattern. The Daly pattern is a repeating 55 octet pattern that is byte-aligned into the active DS0 time slots. The pattern is defined in an ATIS (Alliance for Telecommunications Industry Solutions) Committee T1 Technical Report Number 25 (November 1993).
1	1	1	Pseudo-Random 2E-9-1

Bit 1: Load Bit and Error Counters (LC). A low-to-high transition latches the current bit and error counts into the registers BBC1, BBC2, BBC3, BBC4 and BEC1, BEC2, BEC3 and clears the internal count. This bit should be toggled from low to high whenever the host wishes to begin a new acquisition period. Must be cleared and set again for a subsequent loads.

Bit 0: Force Resynchronization (RESYNC). A low-to-high transition will force the receive BERT synchronizer to resynchronize to the incoming data stream. This bit should be toggled from low to high whenever the host wishes to acquire synchronization on a new pattern. Must be cleared and set again for a subsequent resynchronization.

Register Name: **BC2**
 Register Description: **BERT Control Register 2**
 Register Address: **1106H + (10h x n): where n = 0 to 7, for Ports 1 to 8**

Bit #	7	6	5	4	3	2	1	0
Name	EIB2	EIB1	EIB0	SBE	RPL3	RPL2	RPL1	RPL0
Default	0	0	0	0	0	0	0	0

Bits 7 to 5: Error Insert Bits 2 to 0 (EIB[2:0]). Will automatically insert bit errors at the prescribed rate into the generated data pattern. Can be used for verifying error detection features. See [Table 10-22](#).

Table 10-22. BERT Error Insertion Rate

EIB2	EIB1	EIB0	ERROR RATE INSERTED
0	0	0	No errors automatically inserted
0	0	1	10E-1
0	1	0	10E-2
0	1	1	10E-3
1	0	0	10E-4
1	0	1	10E-5
1	1	0	10E-6
1	1	1	10E-7

Bit 4: Single Bit Error Insert (SBE). A low-to-high transition will create a single bit error. Must be cleared and set again for a subsequent bit error to be inserted.

Bits 3 to 0: Repetitive Pattern Length Select 3 to 0 (RPL[3:0]). RPL0 is the LSB and RPL3 is the MSB of a nibble that describes the how long the repetitive pattern is. The valid range is 17 (0000) to 32 (1111). These bits are ignored if the receive BERT is programmed for a pseudo-random pattern. To create repetitive patterns less than 17 bits in length, the user must set the length to an integer number of the desired length that is less than or equal to 32. For example, to create a 6-bit pattern, the user can set the length to 18 (0001) or to 24 (0111) or to 30 (1101). See [Table 10-23](#).

Table 10-23. BERT Repetitive Pattern Length Select

LENGTH (BITS)	RPL3	RPL2	RPL1	RPL0
17	0	0	0	0
18	0	0	0	1
19	0	0	1	0
20	0	0	1	1
21	0	1	0	0
22	0	1	0	1
23	0	1	1	0
24	0	1	1	1
25	1	0	0	0
26	1	0	0	1
27	1	0	1	0
28	1	0	1	1
29	1	1	0	0
30	1	1	0	1
31	1	1	1	0
32	1	1	1	1

Register Name: **BBC1**
 Register Description: **BERT Bit Count Register 1**
 Register Address: **1107H + (10h x n): where n = 0 to 7, for Ports 1 to 8**

Bit #	7	6	5	4	3	2	1	0
Name	BBC7	BBC6	BBC5	BBC4	BBC3	BBC2	BBC1	BBC0
Default	0	0	0	0	0	0	0	0

Bits 7 to 0: BERT Bit Counter Bits 7 to 0 (BBC[7:0]). BBC0 is the LSB of the 32-bit counter.

Register Name: **BBC2**
 Register Description: **BERT Bit Count Register 2**
 Register Address: **1108H + (10h x n): where n = 0 to 7, for Ports 1 to 8**

Bit #	7	6	5	4	3	2	1	0
Name	BBC15	BBC14	BBC13	BBC12	BBC11	BBC10	BBC9	BBC8
Default	0	0	0	0	0	0	0	0

Bits 7 to 0: BERT Bit Counter Bits 15 to 8 (BBC[15:8]).

Register Name: **BBC3**
 Register Description: **BERT Bit Count Register 3**
 Register Address: **1109H + (10h x n): where n = 0 to 7, for Ports 1 to 8**

Bit #	7	6	5	4	3	2	1	0
Name	BBC23	BBC22	BBC21	BBC20	BBC19	BBC18	BBC17	BBC16
Default	0	0	0	0	0	0	0	0

Bits 7 to 0: BERT Bit Counter Bits 23 to 16 (BBC[23:16]).

Register Name: **BBC4**
 Register Description: **BERT Bit Count Register 4**
 Register Address: **110AH + (10h x n): where n = 0 to 7, for Ports 1 to 8**

Bit #	7	6	5	4	3	2	1	0
Name	BBC31	BBC30	BBC29	BBC28	BBC27	BBC26	BBC25	BBC24
Default	0	0	0	0	0	0	0	0

Bits 7 to 0: BERT Bit Counter Bits 31 to 24 (BBC[31:24]). BBC31 is the MSB of the 32-bit counter.

Register Name: **BEC1**
 Register Description: **BERT Error Count Register 1**
 Register Address: **110BH + (10h x n): where n = 0 to 7, for Ports 1 to 8**

Bit #	7	6	5	4	3	2	1	0
Name	EC7	EC6	EC5	EC4	EC3	EC2	EC1	EC0
Default	0	0	0	0	0	0	0	0

Bits 7 to 0: Error Counter Bits 7 to 0 (EC[7:0]). EC0 is the LSB of the 24-bit counter.

Register Name: **BEC2**
 Register Description: **BERT Error Count Register 2**
 Register Address: **110CH + (10h x n): where n = 0 to 7, for Ports 1 to 8**

Bit #	7	6	5	4	3	2	1	0
Name	EC15	EC14	EC13	EC12	EC11	EC10	EC9	EC8
Default	0	0	0	0	0	0	0	0

Bits 7 to 0: Error Counter Bits 15 to 8 (EC[15:8]).

Register Name: **BEC3**
 Register Description: **BERT Error Count Register 3**
 Register Address: **110DH + (10h x n): where n = 0 to 7, for Ports 1 to 8**

Bit #	7	6	5	4	3	2	1	0
Name	EC23	EC22	EC21	EC20	EC19	EC18	EC17	EC16
Default	0	0	0	0	0	0	0	0

Bits 7 to 0: Error Counter Bits 23 to 16 (EC[23:16]). EC23 is the MSB of the 24-bit counter.

Register Name: **BLSR**
 Register Description: **Bert Latched Status Register**
 Register Address: **110EH + (10h x n): where n = 0 to 7, for Ports 1 to 8**

Bit #	7	6	5	4	3	2	1	0
Name	-	BBED	BBCO	BECO	BRA1	BRA0	BRLOS	BSYNC
Default	0	0	0	0	0	0	0	0

All bits in this register are latched and can create interrupts.

Bit 6: BERT Bit Error Detected (BED) Event (BBED). A latched bit, which is set when a bit error is detected. The receive BERT must be in synchronization for it to detect bit errors.

Bit 5: BERT Bit Counter Overflow Event (BBCO). A latched bit, which is set when the 32-bit BERT Bit Counter (BBC) overflows.

Bit 4: BERT Error Counter Overflow Event (BECO). A latched bit, which is set when the 24-bit BERT Error Counter (BEC) overflows.

Bit 3: BERT Receive All-Ones Condition (BRA1). A latched bit, which is set when 32 consecutive ones are received.

Bit 2: BERT Receive All-Zeros Condition (BRA0). A latched bit, which is set when 32 consecutive zeros are received.

Bit 1: BERT Receive Loss Of Synchronization Condition (BRLOS). A latched bit, which is set whenever the receive BERT begins searching for a pattern.

Bit 0: BERT in Synchronization Condition (BSYNC). Will be set when the incoming pattern matches for 32 consecutive bit positions.

Register Name: **BSIM**
 Register Description: **BERT Status Interrupt Mask Register**
 Register Address: **110FH + (10h x n): where n = 0 to 7, for Ports 1 to 8**

Bit #	7	6	5	4	3	2	1	0
Name	-	BBED	BBCO	BECO	BRA1	BRA0	BRLOS	BSYNC
Default	0	0	0	0	0	0	0	0

Bit 6 : Bit Error Detected Event (BBED).

0 = interrupt masked
 1 = interrupt enabled

Bit 5 : BERT Bit Counter Overflow Event (BBCO).

0 = interrupt masked
 1 = interrupt enabled

Bit 4 : BERT Error Counter Overflow Event (BECO).

0 = interrupt masked
 1 = interrupt enabled

Bit 3 : Receive All Ones Condition (BRA1).

0 = interrupt masked
 1 = interrupt enabled – interrupts on rising and falling edges

Bit 2 : Receive All Zeros Condition (BRA0).

0 = interrupt masked
 1 = interrupt enabled – interrupts on rising and falling edges

Bit 1 : Receive Loss Of Synchronization Condition (BRLOS)

0 = interrupt masked
 1 = interrupt enabled – interrupts on rising and falling edges

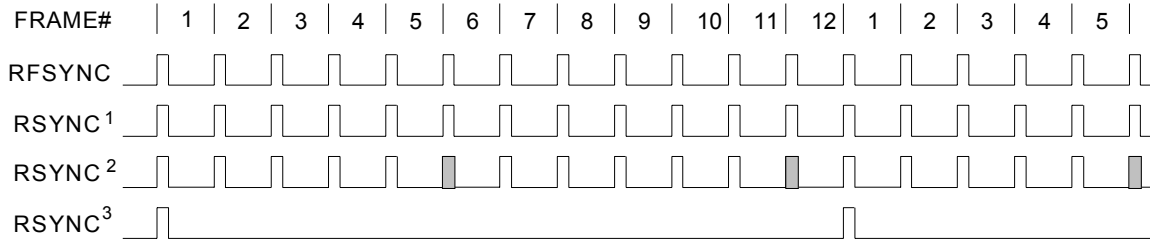
Bit 0 : BERT in Synchronization Condition (BSYNC).

0 = interrupt masked
 1 = interrupt enabled – interrupts on rising and falling edges

11. FUNCTIONAL TIMING

11.1 T1 Receiver Functional Timing Diagrams

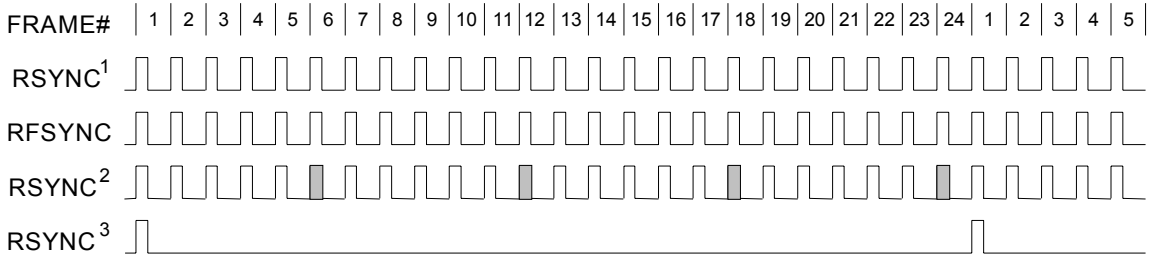
Figure 11-1. T1 Receive Side D4 Timing



Notes:

1. RSYNC in the frame mode (RIOCR.0 = 0) and doublewide frame sync is not enabled (RIOCR.1 = 0)
2. RSYNC in the frame mode (RIOCR.0 = 0) and doublewide frame sync is enabled (RIOCR.1 = 1)
3. RSYNC in the multiframe mode (RIOCR.0 = 1)

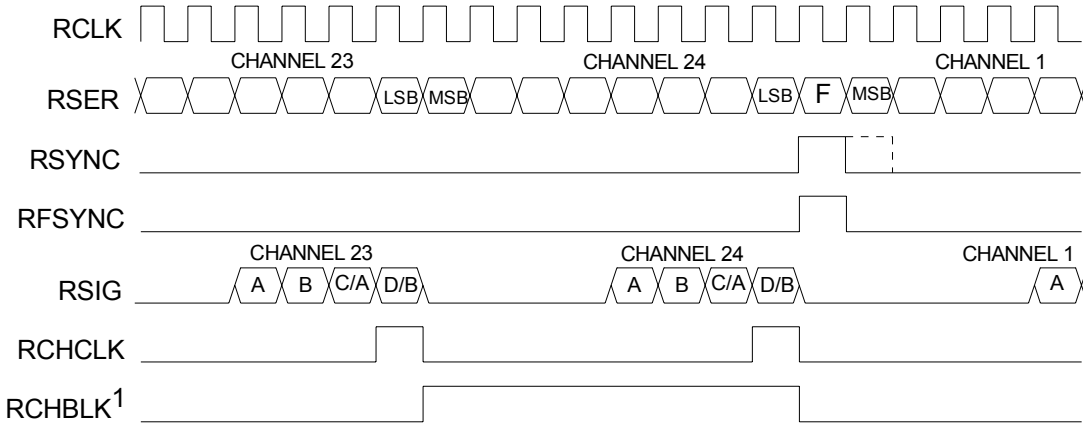
Figure 11-2. T1 Receive Side ESF Timing



Notes:

1. RSYNC in frame mode (RIOCR.0 = 0) and doublewide frame sync is not enabled (RIOCR.1 = 0)
2. RSYNC in frame mode (RIOCR.0 = 0) and doublewide frame sync is enabled (RIOCR.1 = 1)
3. RSYNC in multiframe mode (RIOCR.0 = 1)

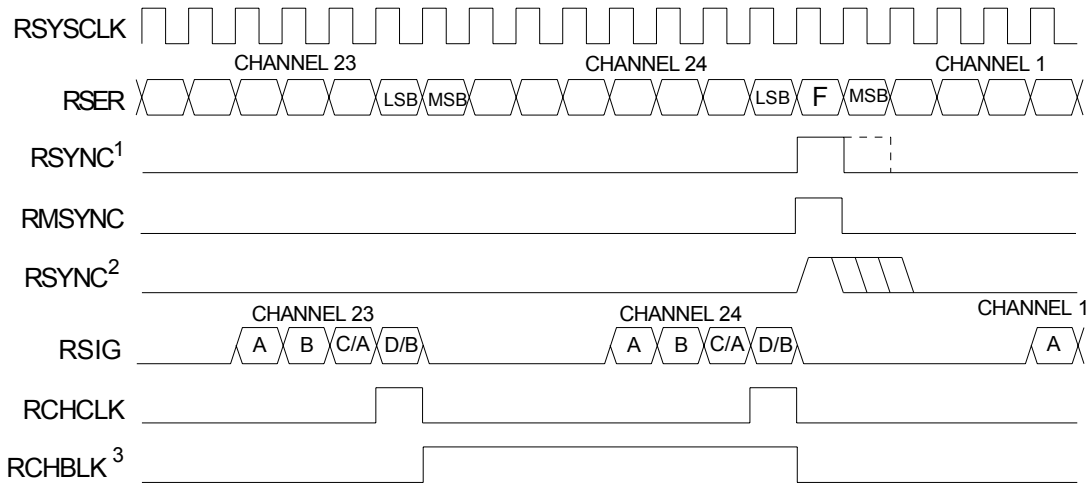
Figure 11-3. T1 Receive Side Boundary Timing (elastic store disabled)



Notes:

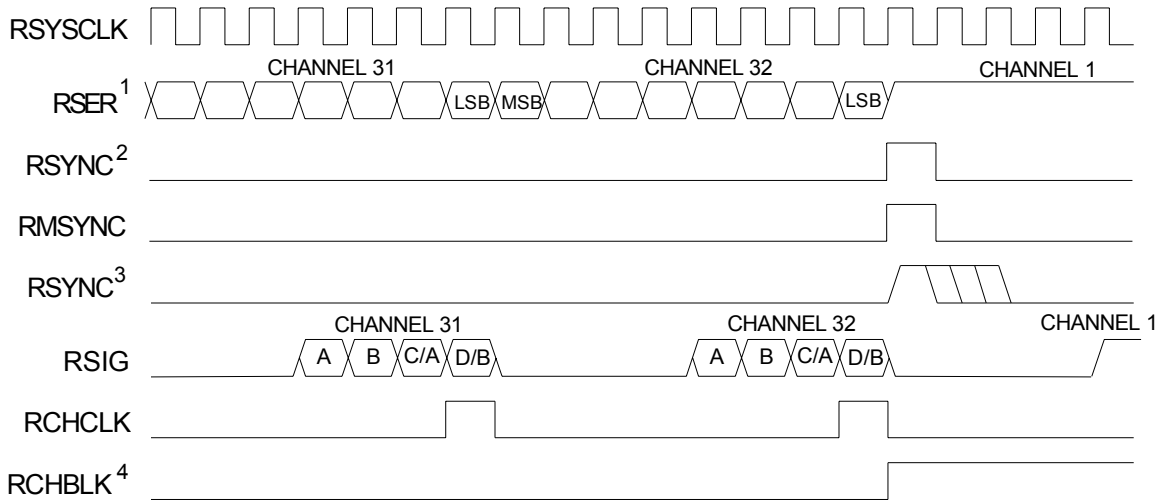
1. RCHBLK is programmed to block channel 24

Figure 11-4. T1 Receive Side 1.544MHz Boundary Timing (e-store enabled)



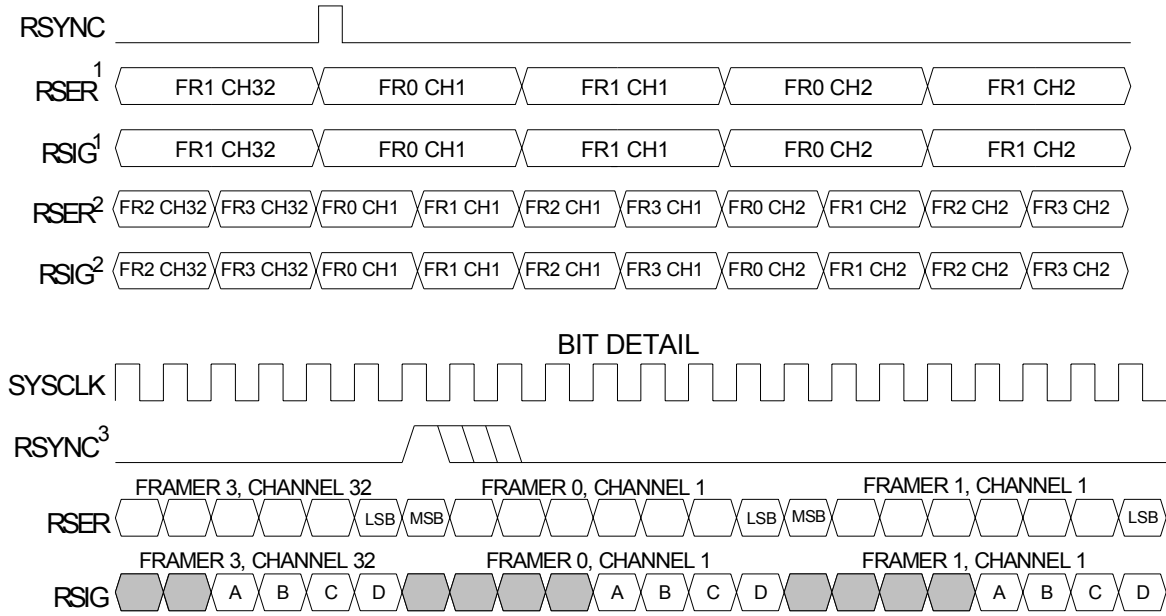
Notes:

1. RSYNC is in the output mode (RIOCR.2 = 0)
2. RSYNC is in the input mode (RIOCR.2 = 1)
3. RCHBLK is programmed to block channel 24

Figure 11-5. T1 Receive Side 2.048MHz Boundary Timing (e-store enabled)**Notes:**

1. RSER data in channels 1, 5, 9, 13, 17, 21, 25, and 29 are forced to one
2. RSYNC is in the output mode (RIOCR.2 = 0)
3. RSYNC is in the input mode (RIOCR.2 = 1)
4. RCHBLK is programmed to block channel 1
5. The F-Bit position is passed through the receive side elastic store

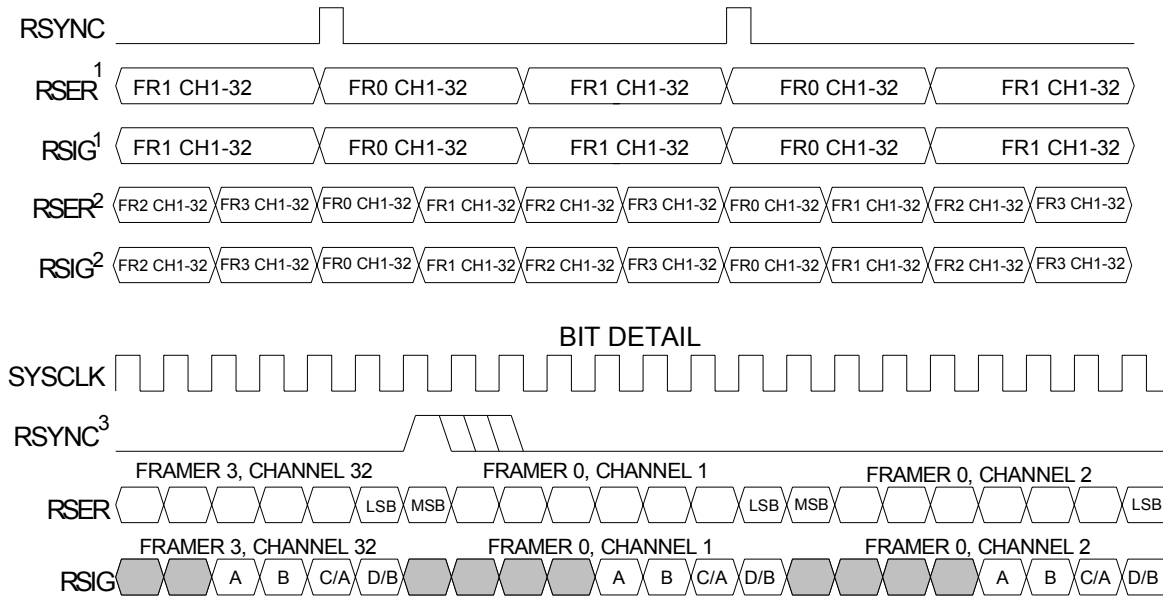
Figure 11-6. T1 Receive Side Interleave Bus Operation, BYTE Mode



Notes:

1. 4.096 MHz bus configuration.
2. 8.192 MHz bus configuration.
3. RSYNC is in the input mode (RIOCR.2 = 0)
4. Shows system implementation with multiple DS26528 cores driving backplane
5. Though not shown, TCHCLK continues to mark the channel LSB for the framer's active period.
6. Though not shown, TCHBLK continues to mark the blocked channels for the framers active period.

Figure 11-7. T1 Receive Side Interleave Bus Operation, FRAME Mode

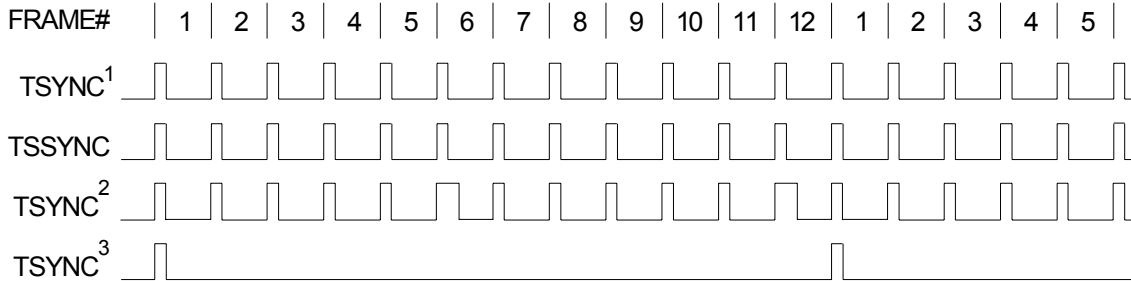


Notes:

1. 4.096 MHz bus configuration.
2. 8.192 MHz bus configuration.
3. RSYNC is in the input mode (RIOCR.2 = 0).
4. Shows system implementation with multiple DS26528 cores driving backplane
4. Though not shown, RCHCLK continues to mark the channel LSB for the framer's active period.
5. Though not shown, RCHBLK continues to mark the blocked channels for the framers active period.

11.2 T1 Transmitter Functional Timing Diagrams

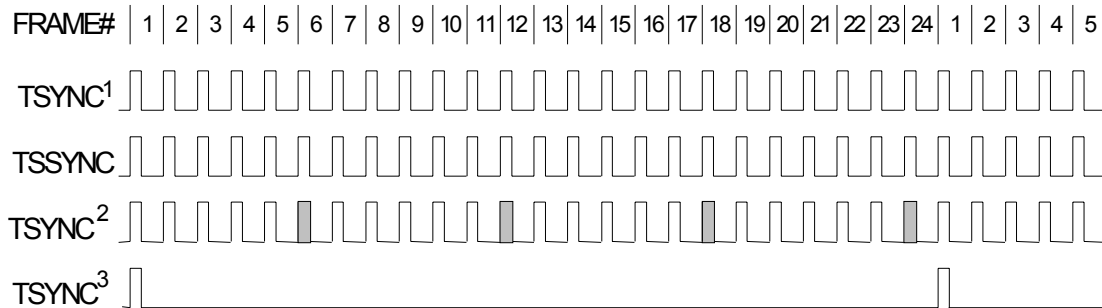
Figure 11-8. T1 Transmit Side D4 Timing



Notes:

1. TSYNC in the frame mode (TIOCR.0 = 0) and doublewide frame sync is not enabled (TIOCR.1 = 0)
2. TSYNC in the frame mode (TIOCR.0 = 0) and doublewide frame sync is enabled (TIOCR.1 = 1)
3. TSYNC in the multiframe mode (TIOCR.0 = 1)

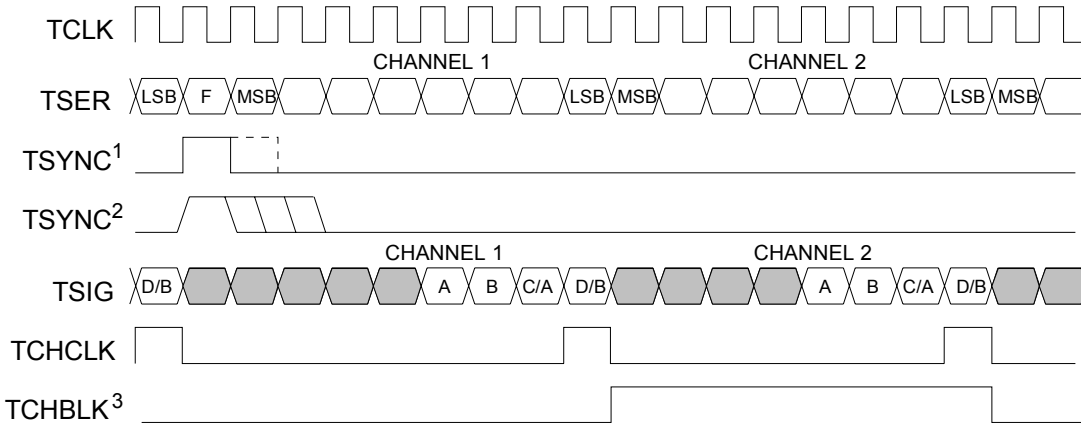
Figure 11-9. T1 Transmit Side ESF Timing



Notes:

1. TSYNC in frame mode (TIOCR.0 = 0) and doublewide frame sync is not enabled (TIOCR.1 = 0)
2. TSYNC in frame mode (TIOCR.0 = 0) and doublewide frame sync is enabled (TIOCR.1 = 1)
3. TSYNC in multiframe mode (TIOCR.0 = 1)

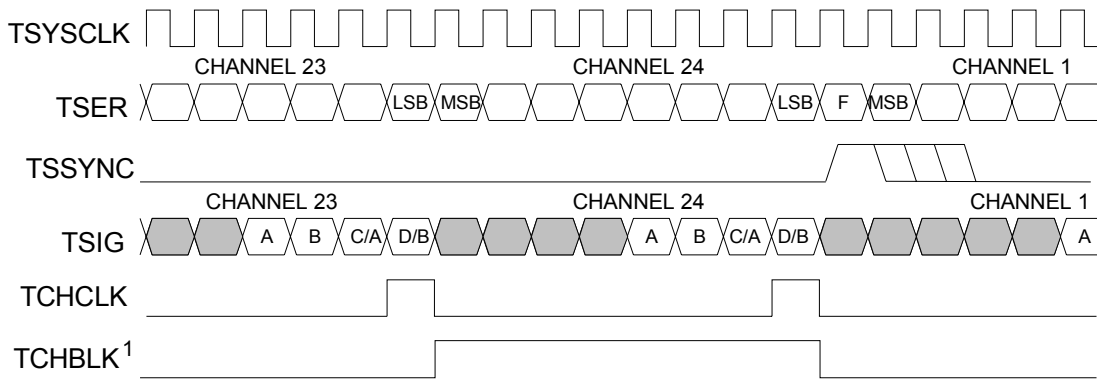
Figure 11-10. T1 Transmit Side Boundary Timing (e-store disabled)



Notes:

1. TSYNC is in the output mode (TIOCR.2 = 1)
2. TSYNC is in the input mode (TIOCR.2 = 0)
3. TCHBLK is programmed to block channel 2

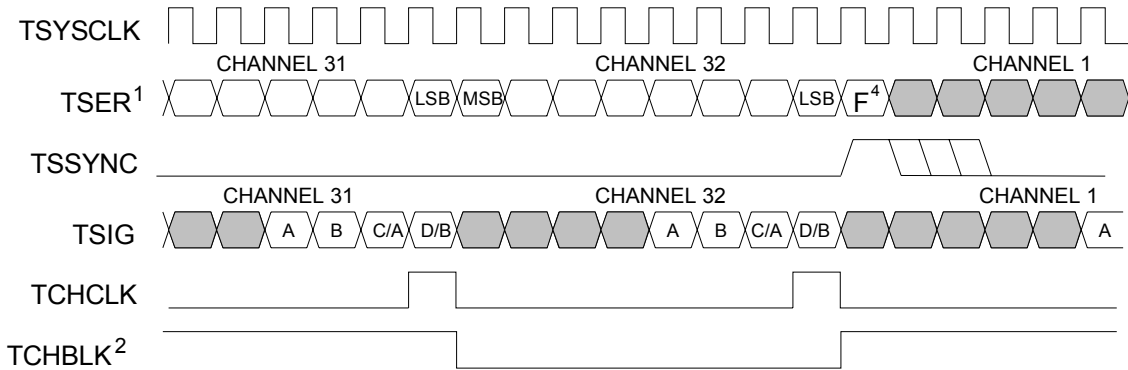
Figure 11-11. T1 Transmit Side 1.544MHz Boundary Timing (e-store enabled)



Notes:

1. TCHBLK is programmed to block channel 24

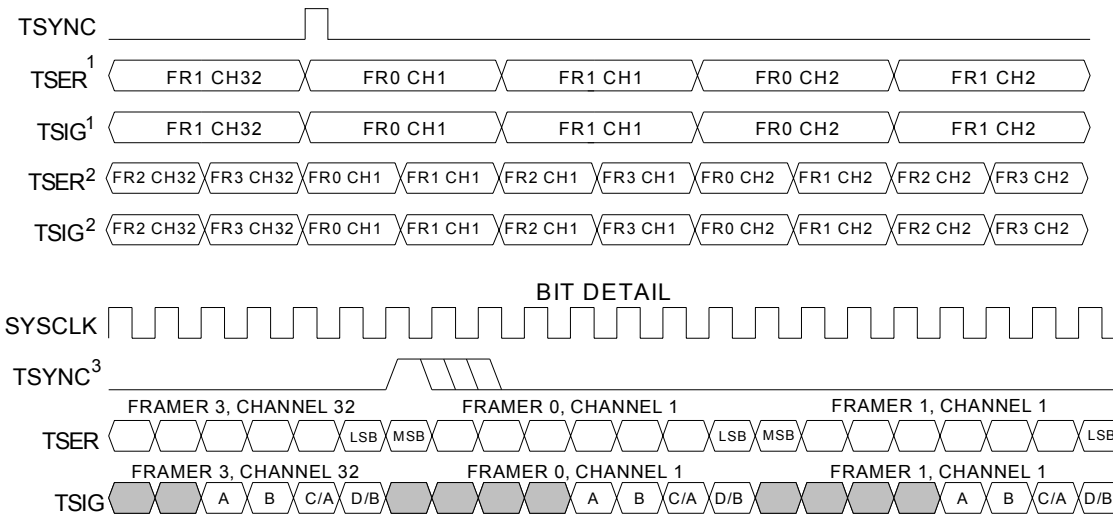
Figure 11-12. T1 Transmit Side 2.048MHz Boundary Timing (e-store enabled)



Notes:

1. TSER data in channels 1, 5, 9, 13, 17, 21, 25, and 29 is ignored
2. TCHBLK is programmed to block channels 31 and 1
3. The F-bit position for the T1 frame is sampled and passed through the transmit side elastic store into the MSB bit position of channel 1. (normally the transmit side formatter overwrites the F-bit position unless the formatter is programmed to pass-through the F-bit position)

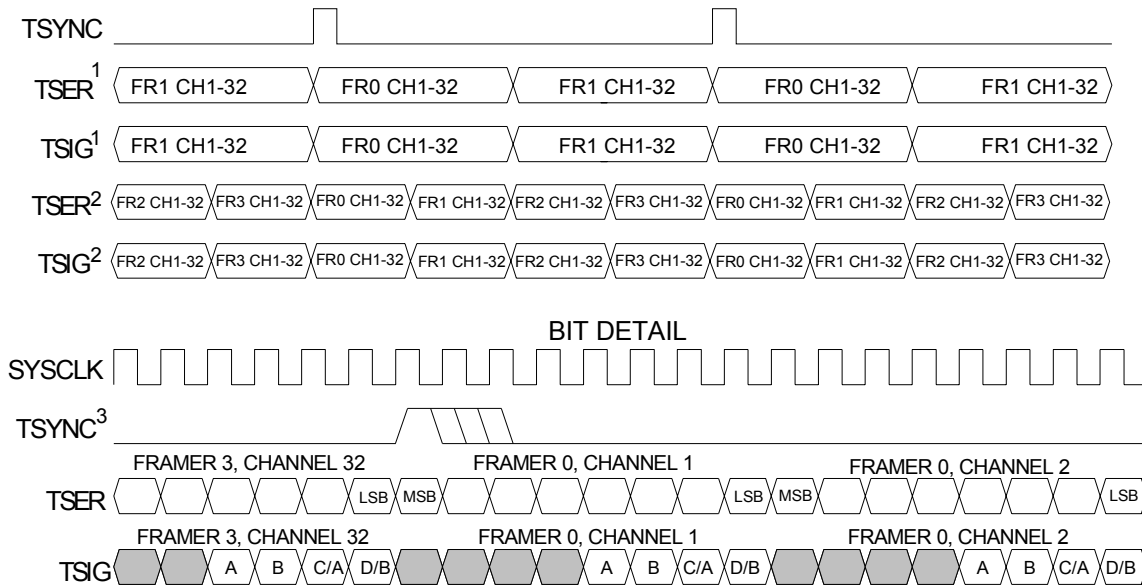
Figure 11-13. T1 Transmit Side Interleave Bus Operation, BYTE Mode



Notes:

1. 4.096 MHz bus configuration.
2. 8.192 MHz bus configuration.
3. TSYNC is in the input mode (TIOCR.2 = 0).
4. Though not shown, TCHCLK continues to mark the channel LSB for the framer's active period.
5. Though not shown, TCHBLK continues to mark the blocked channels for the framers active period.

Figure 11-14. T1 Transmit Interleave Bus Operation, FRAME Mode



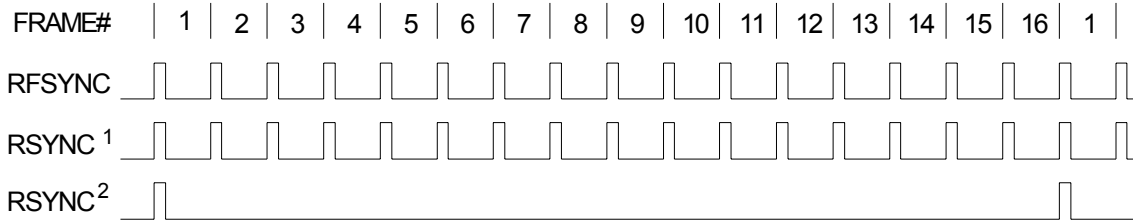
Notes:

1. 4.096 MHz bus configuration.
2. 8.192 MHz bus configuration.
3. TSYNC is in the input mode (TIOCR.2 = 0).
4. Though not shown, TCHCLK continues to mark the channel LSB for the framer's active period.
5. Though not shown, TCHBLK continues to mark the blocked channels for the framers active period.

11.3 E1 Receiver Functional Timing Diagrams

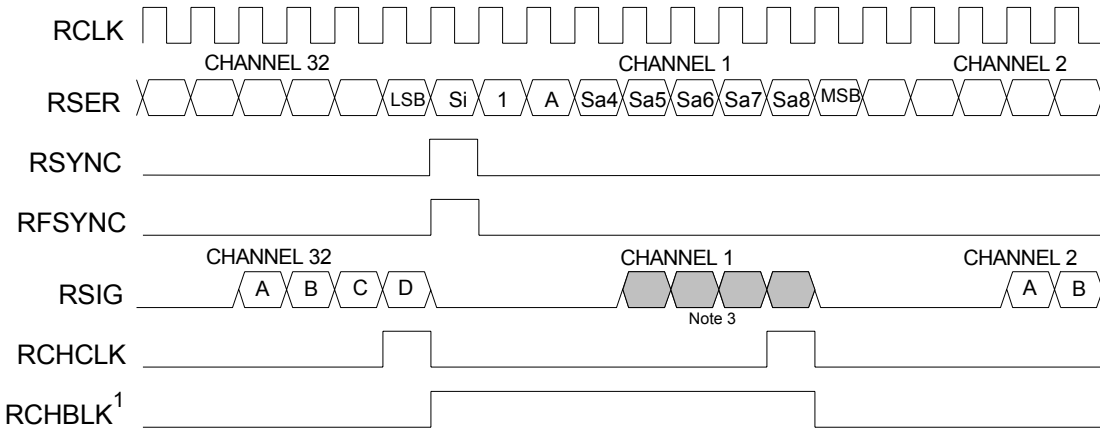
Figure 11-15. E1 Receive Side Timing

Notes:



1. RSYNC in frame mode (RIOCR.0 = 0)
2. RSYNC in multiframe mode (RIOCR.0 = 1)
3. This diagram assumes the CAS MF begins in the RAF frame

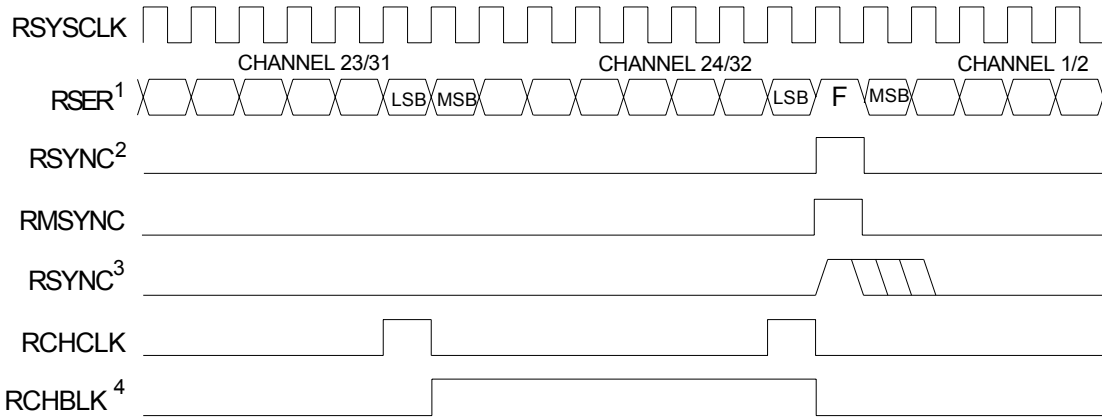
Figure 11-16. E1 Receive Side Boundary Timing (elastic store disabled)



Notes:

1. RCHBLK is programmed to block channel 1
2. Shown is a RNAF frame boundary
3. RSIG normally contains the CAS multiframe alignment nibble (0000) in channel 1

Figure 11-17. E1 Receive Side 1.544MHz Boundary Timing (e-store enabled)



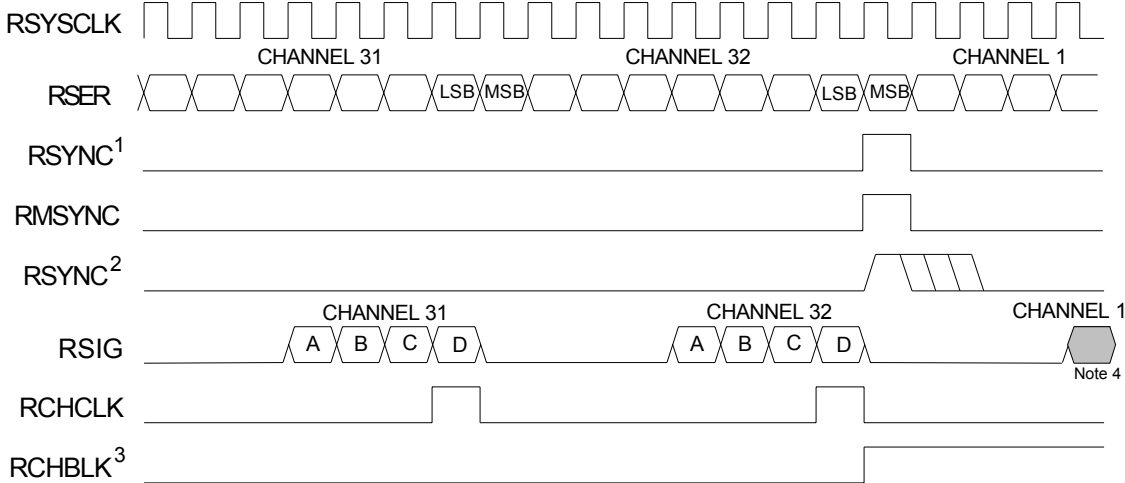
Notes:

1. Data from the E1 channels 1, 5, 9, 13, 17, 21, 25, and 29 is dropped (channel 2 from the E1 link is (mapped to channel 1 of the T1 link, etc.) and the F-bit position is added (forced to one)
2. RSYNC in the output mode (RIOCR.2 = 0)
3. RSYNC in the input mode (RIOCR.2 = 1)
4. RCHBLK is programmed to block channel 24

Figure 11-18. E1 Receive Side 2.048MHz Boundary Timing (e-store enabled)

Notes:

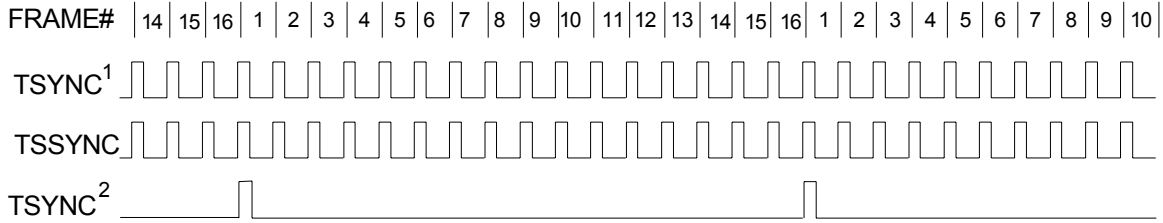
1. RSYNC is in the output mode (RIOCR.2 = 0)



2. RSYNC is in the input mode (RIOCR.2 = 1)
3. RCHBLK is programmed to block channel 1
4. RSIG normally contains the CAS multiframe alignment nibble (0000) in Channel 1

11.4 E1 Transmitter Functional Timing Diagrams

Figure 11-19. E1 Transmit Side Timing

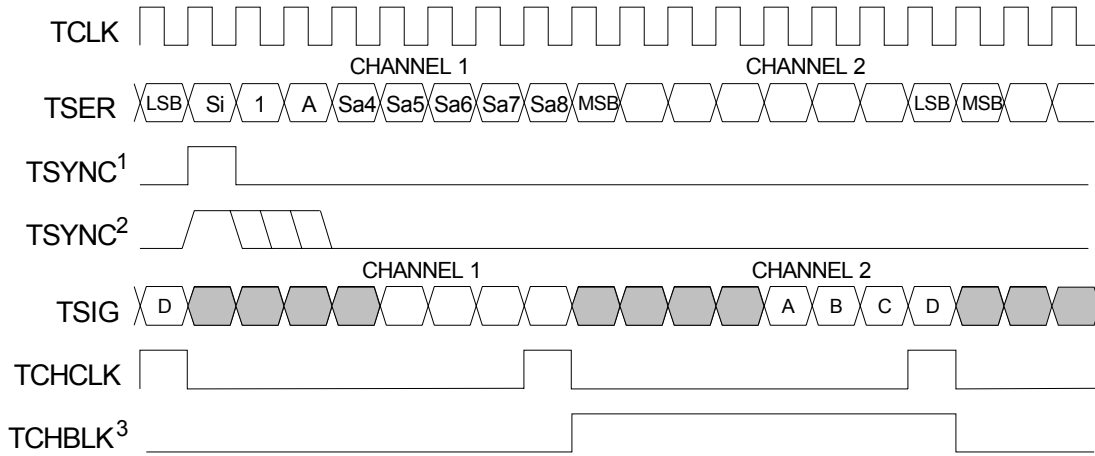


Notes:

1. TSYNC in frame mode (TIOCR.0 = 0)
2. TSYNC in multiframe mode (TIOCR.0 = 1)
3. This diagram assumes both the CAS MF and the CRC4 MF begin with the TAF frame

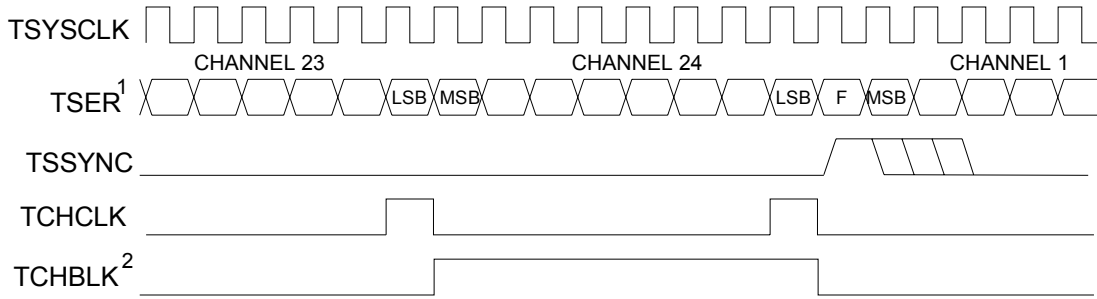
Figure 11-20. E1 Transmit Side Boundary Timing (elastic store disabled)

Notes:



1. TSYNC is in the output mode (TIOCR.2 = 1)
2. TSYNC is in the input mode (TIOCR.2 = 0)
3. TCHBLK is programmed to block channel 2
4. The signaling data at TSIG during channel 1 is normally overwritten in the transmit formatter with the CAS MF alignment nibble (0000)
5. Shown is a TNAF frame boundary

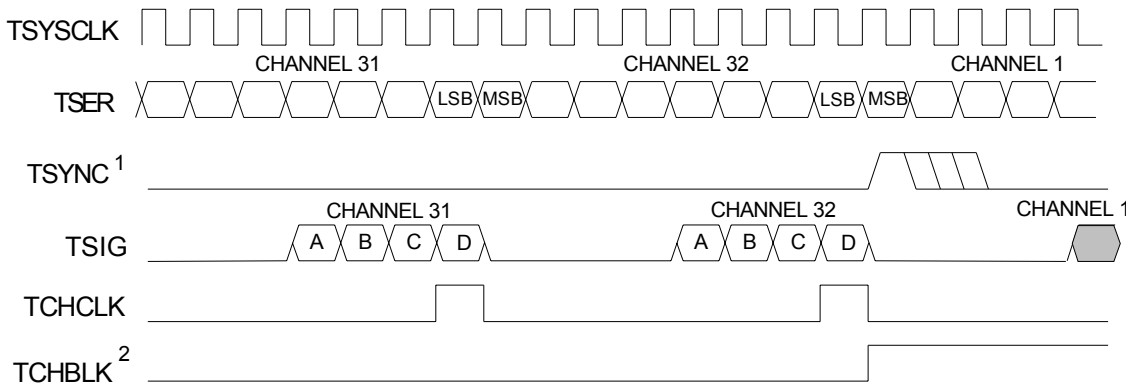
Figure 11-21. E1 Transmit Side 1.544MHz Boundary Timing (e-store enabled)



Notes:

1. The F bit position in the TSER data is ignored
2. TCHBLK is programmed to block channel 24

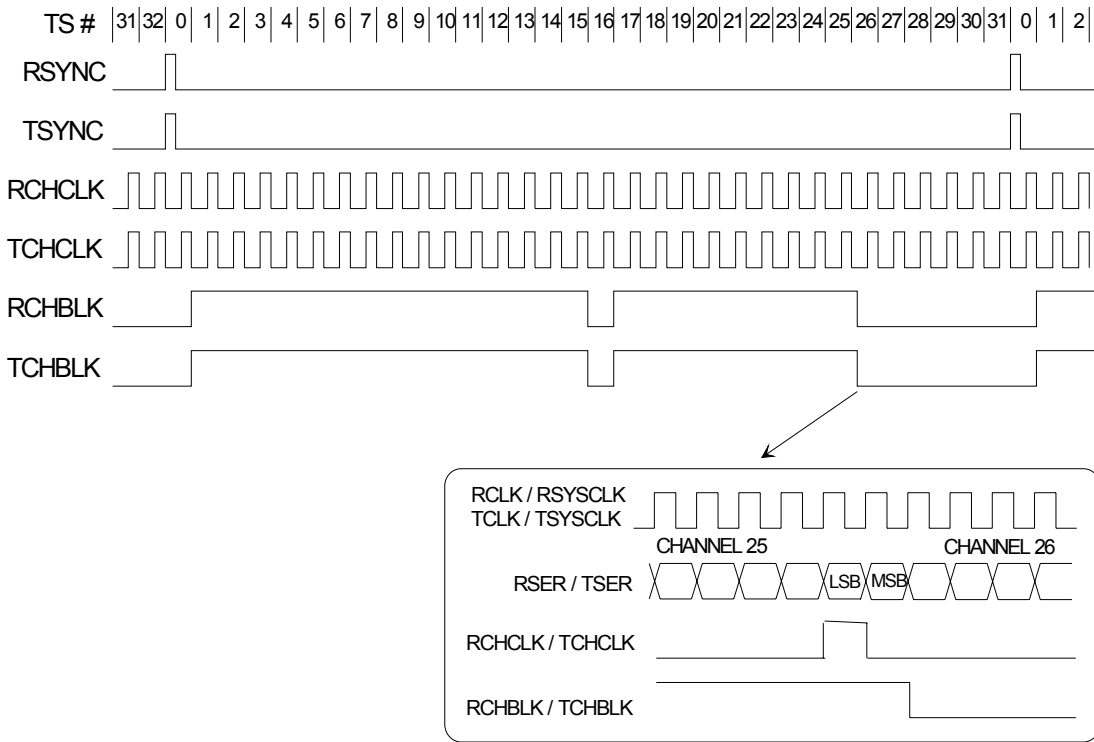
Figure 11-22. E1 Transmit Side 2.048MHz Boundary Timing (e-store enabled)



Notes:

1. TSYNC is in the input mode (TIOCR.2 = 0)
2. TCHBLK is programmed to block channel 1

Figure 11-23. E1 G.802 Timing



NOTES:

RCHBLK or TCHBLK programmed to pulse high during time slots 1 through 15, 17 through 25, and bit 1 of time slot 26

12. OPERATING PARAMETERS

ABSOLUTE MAXIMUM RATINGS

Voltage Range on Any Lead with Respect to V_{SS} (except V_{DD}).....	-0.3V to +5.5V
Supply Voltage (V_{DD}) Range with Respect to V_{SS}	-0.3V to +3.63V
Operating Temperature Range for DS26528.....	0°C to +70°C
Operating Temperature Range for DS26528N.....	-40°C to +85°C
Storage Temperature Range.....	-55°C to +125°C
Soldering Temperature.....	See IPC/JEDEC J-STD-020A Specification

This is a stress rating only and functional operation of the device at these or any other conditions above those indicated in the operation sections of this specification is not implied. Exposure to absolute maximum rating conditions for extended periods of time may affect reliability.

RECOMMENDED DC OPERATING CONDITIONS

($T_A = -40^\circ\text{C}$ to $+85^\circ\text{C}$ for DS26528N.)

PARAMETER	SYMBOL	MIN	TYP	MAX	UNITS	NOTES
Logic 1	V_{IH}	2.0		5.5	V	
Logic 0	V_{IL}	-0.3		+0.8	V	
Supply	V_{DD}	3.135	3.3	3.465	V	

CAPACITANCE

($T_A = +25^\circ\text{C}$)

PARAMETER	SYMBOL	MIN	TYP	MAX	UNITS	NOTES
Input Capacitance	C_{IN}		7		pF	
Output Capacitance	C_{OUT}		7		pF	

RECOMMENDED DC OPERATING CONDITIONS

($V_{DD} = 3.135\text{V}$ to 3.465V , $T_A = -40^\circ\text{C}$ to $+85^\circ\text{C}$.)

PARAMETER	SYMBOL	MIN	TYP	MAX	UNITS	NOTES
Supply Current at 3.3V	I_{DD}		575	875	mA	1, 2
Input Leakage	I_{IL}	-10.0		+10.0	μA	
Pullup Pin Input Leakage	I_{ILP}	-500.0		+10.0	μA	3
Tri-State Output Leakage	I_{OL}	-10.0		+10.0	μA	
Output Voltage ($I_o = -1.6\text{mA}$)	V_{OH}	2.4			V	
Output Voltage ($I_o = +0.4\text{mA}$)	V_{OL}			0.4	V	

Note 1: RCLK1-n = TCLK1-n = 2.048MHz.

Note 2: Max power dissipation is measured with all ports transmitting an all-ones data pattern with a transmitter load of 100Ω .

Note 3: Pullup pins include DIGIOEN, JTRST, JTMS, and JTDI.

THERMAL CHARACTERISTICS

PARAMETER	MIN	TYP	MAX	UNITS	NOTES
Ambient Temperature	-40		+85	°C	1
Junction Temperature			+125	°C	
Theta-JA (θ_{JA}) in Still Air for 256-Pin TE-CSBGA		+17.5		°C/W	2

Note 1: The package is mounted on a four-layer JEDEC standard test board.

Note 2: Theta-JA (θ_{JA}) is the junction-to-ambient thermal resistance, when the package is mounted on a four-layer JEDEC standard test board.

12.1 Line Interface Characteristics

Table 12-1. Transmitter Characteristics

PARAMETER	SYMBOL	CONDITIONS	MIN	TYP	MAX	UNITS	NOTES
Output Mark Amplitude	V_m	E1 75 Ω	2.13	2.37	2.61	V	
		E1 120 Ω	2.70	3.00	3.30		
		T1 100 Ω	2.40	3.00	3.60		
		J1 110 Ω	2.40	3.00	3.60		
Output Zero Amplitude	V_s		-0.3		+0.3	V	1
Transmit Amplitude Variation with Supply			-1		+1	%	

Table 12-2. Receiver Characteristics

PARAMETER	SYMBOL	CONDITIONS	MIN	TYP	MAX	UNITS	NOTES
Cable Attenuation	Attn				43	dB	
Allowable Zeros Before Loss				192			1
				192			
				2048			
Allowable Ones Before Loss				24			2
				192			
				192			

Note 1: 192 Zeros for T1 and T1.231 Specification Compliance. 192 Zeros for E1 and G.775 Specification Compliance. 2048 Zeros for ETSI 300 233 compliance.

Note 2: 24 ones in 192-bit period for T1.231; 192 ones for G.775; 192 ones for ETSI 300 233.

13. AC TIMING CHARACTERISTICS

Unless otherwise noted, all timing numbers assume 20pF test load on output signals, 40pF test load on bus signals.

13.1 Microprocessor Bus AC Characteristics

Table 13-1. AC Characteristics –Microprocessor Bus Timing

($V_{DD} = 3.3V \pm 5\%$, $T_A = 0^\circ C$ to $+70^\circ C$ for DS26528; $V_{DD} = 3.3V \pm 5\%$, $T_A = -40^\circ C$ to $+85^\circ C$ for DS26528N.)

PARAMETER	SYMBOL	MIN	TYP	MAX	UNITS	NOTES
Setup Time for A[7:0] Valid to \overline{CSB} Active	t1	0			ns	
Setup Time for \overline{CSB} Active to either \overline{RDB} , or \overline{WRB} Active	t2	0			ns	
Delay Time from Either \overline{RDB} or \overline{DSB} Active to D:AD[7:0] Valid	t3			125	ns	1
Hold Time from Either \overline{RDB} or \overline{WRB} Inactive to \overline{CSB} Inactive	t4	0			ns	
Hold Time from \overline{CSB} or \overline{RDB} or \overline{DSB} Inactive to D:AD[7:0] Tri-State	t5	5		20	ns	
Wait Time from \overline{WRB} Active to Latch Data	t6	40			ns	
Data Setup Time to \overline{WRB} Inactive	t7	10			ns	
Data Hold Time from \overline{WRB} Inactive	t8	2			ns	
Address Hold from \overline{WRB} Inactive	t9	0			ns	
Write Access to Subsequent Write/Read Access Delay Time	t10	80			ns	1

Note 1: If supplying a 1.544MHz MCLK, the FREQSEL bit must be set to meet this timing.

Figure 13-1. Intel Bus Read Timing (BTS = 0)

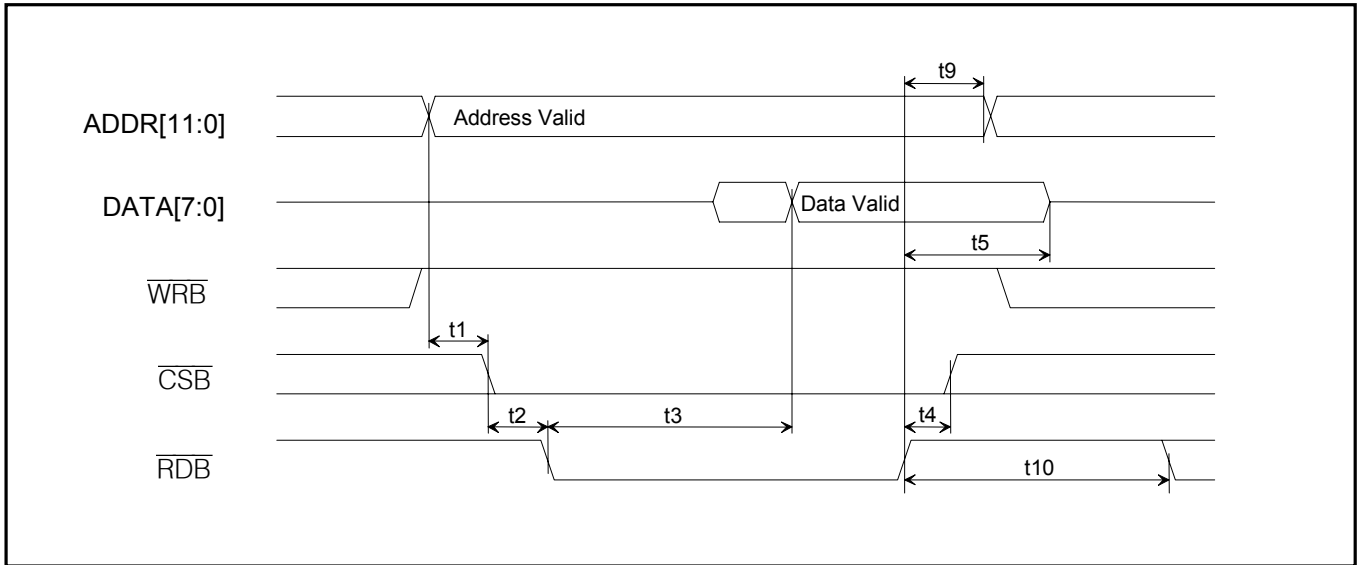


Figure 13-2. Intel Bus Write Timing (BTS = 0)

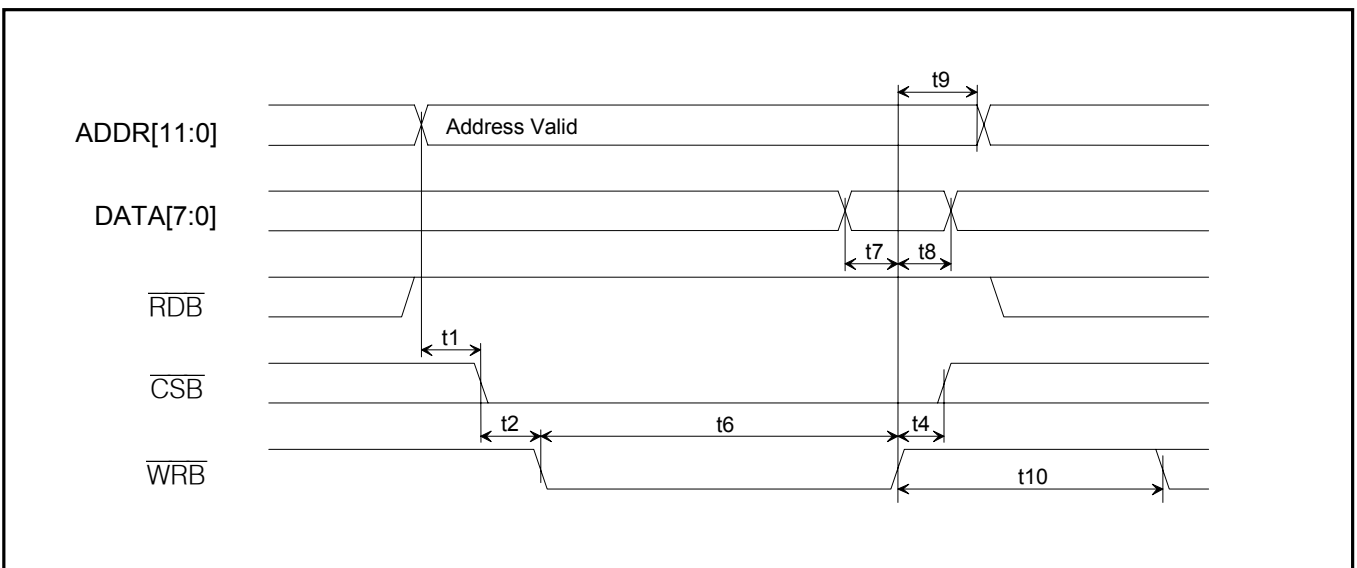


Figure 13-3. Motorola Bus Read Timing (BTS = 1)

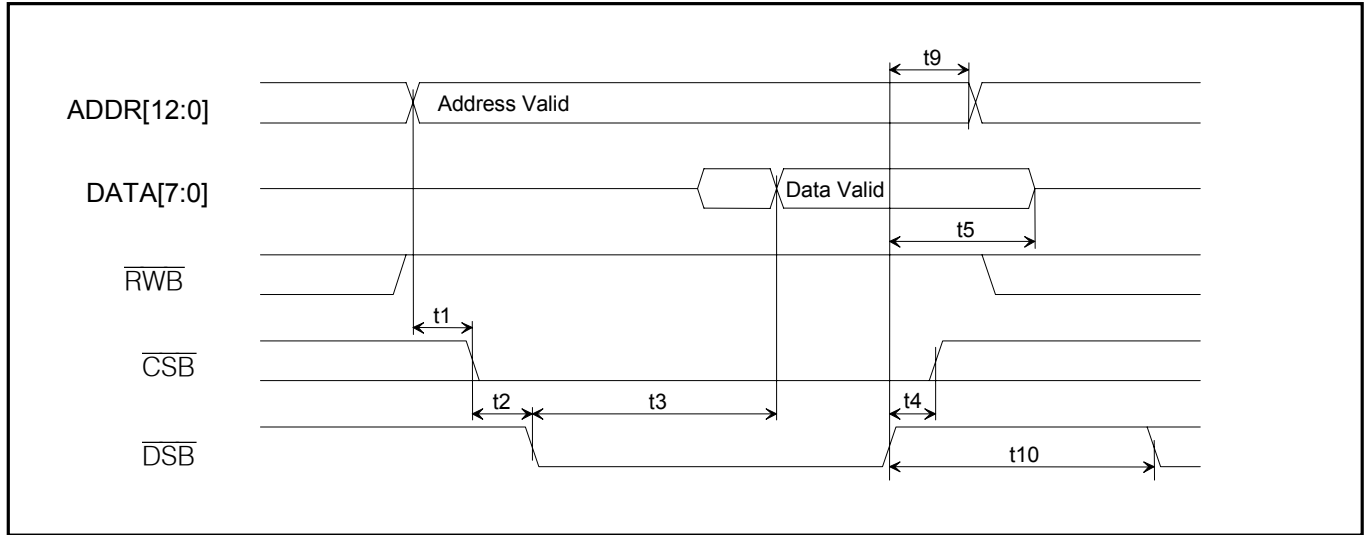


Figure 13-4. Motorola Bus Write Timing (BTS = 1)

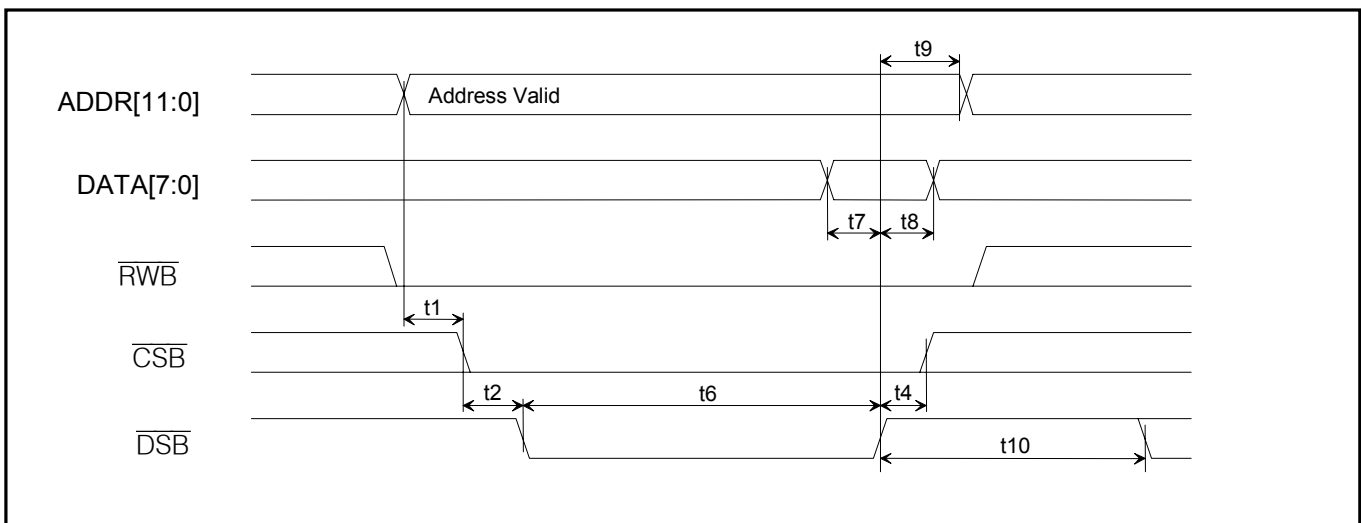


Table 13-2. Receiver AC Characteristics(V_{DD} = 3.3V ± 5%, T_A = -40°C to +85°C.)

PARAMETER	SYMBOL	MIN	TYP	MAX	UNITS	NOTES
RCLK Period	t _{CP}		648		ns	1
			488			2
RCLK Pulse Width	t _{CH}	125			ns	
	t _{CL}	125				
RSYSCLK Period	t _{SP}	60	648		ns	3
		60	488			4
RSYSCLK Pulse Width	t _{SH}	30			ns	
	t _{SL}	30				
RSYNC Setup to RSYSCLK Falling	t _{SU}	20		t _{SH} - 5	ns	
RSYNC Pulse Width	t _{PW}	50			ns	
RPOS:RNEG Setup to RCLK Falling	t _{SU}	20			ns	
RPOS:RNEG Hold From RCLK Falling	t _{HD}	20			ns	
Delay RCLK to RSER, RSIG Valid	t _{D1}			50	ns	
Delay RCLK to RCHCLK, RSYNC, RCHBLK, RFSYNC	t _{D2}			50	ns	
Delay RSYSCLK to RSER, RSIG Valid	t _{D3}			50	ns	
Delay RSYSCLK to RCHCLK, RCHBLK, RMSYNC, RSYNC	t _{D4}			50	ns	

Note 1: T1 Mode.**Note 2:** E1 Mode.**Note 3:** RSYSCLK = 1.544MHz.**Note 4:** RSYSCLK = 2.048MHz.

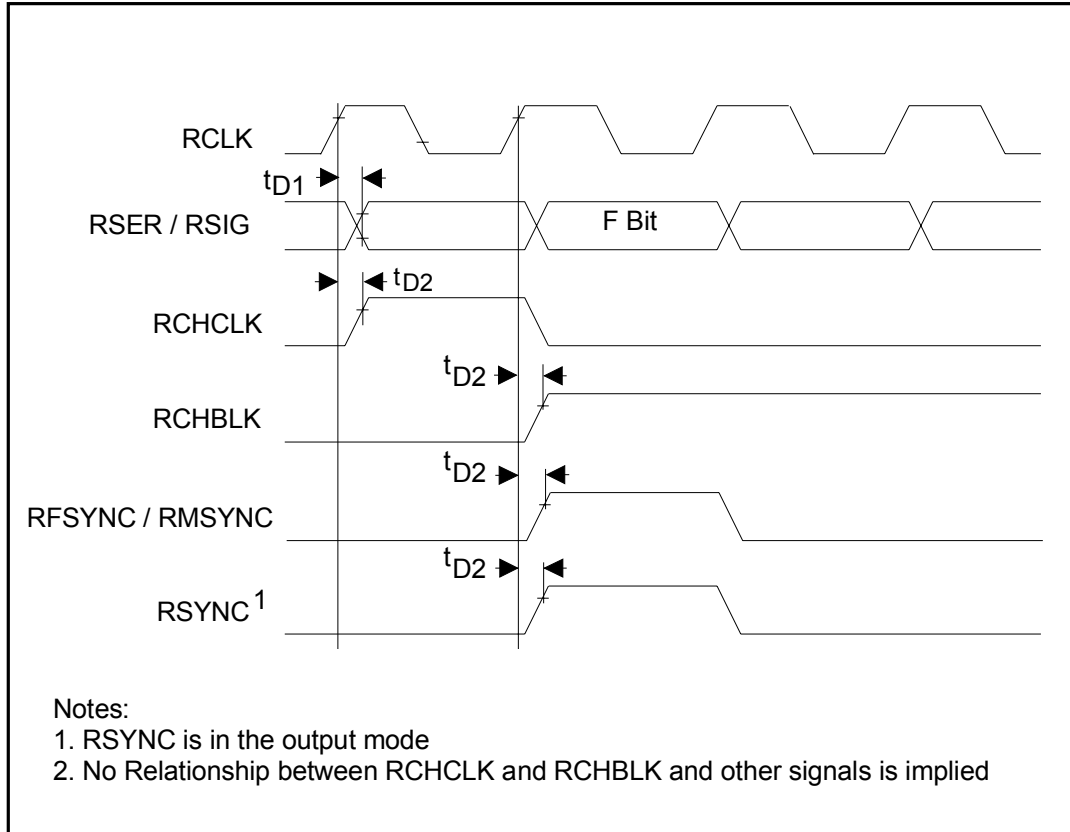
Figure 13-5. Receive Framer Timing—Backplane (T1 Mode)

Figure 13-6. Receive Side Timing, Elastic Store Enabled (T1 Mode)

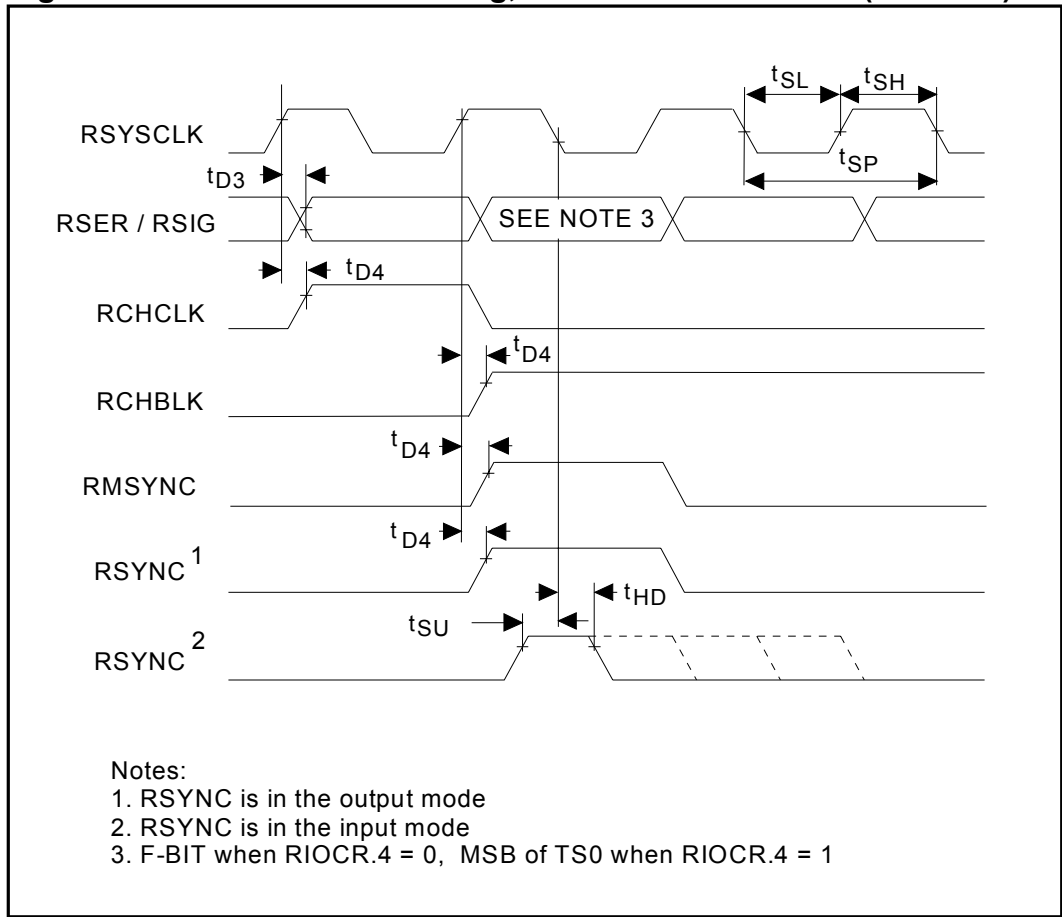


Figure 13-7. Receive Framer Timing—Line Side

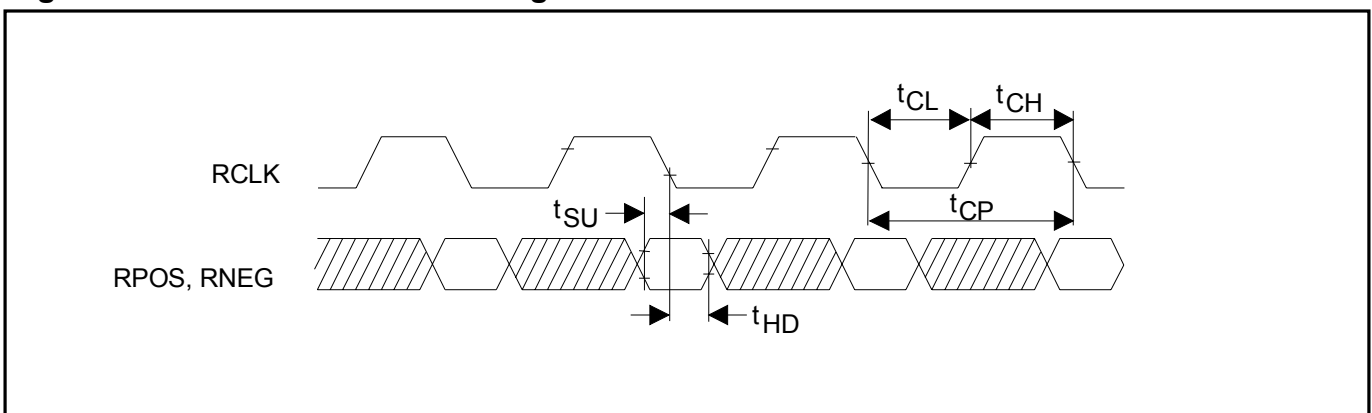


Table 13-3. Transmit AC Characteristics(V_{DD} = 3.3V ±5%, T_A = -40°C to +85°C.)

PARAMETER	SYMBOL	MIN	TYP	MAX	UNITS	NOTES
TCLK Period	t _{CP}		648		ns	1
	t _{CP}		488			2
TCLK Pulse Width	t _{CH}	125			ns	
	t _{CL}	125				
TSYSCLK Period	t _{SP}	60	648		ns	3
	t _{SP}	60	448			4
TSYSCLK Pulse Width	t _{SH}	30			ns	
	t _{SL}	30				
TSYNC or TSSYNCIO Setup to TCLK or TSYSCLK falling	t _{SU}	20		t _{CH} - 5 or t _{SH} - 5	ns	
TSYNC or TSSYNCIO Pulse Width	t _{PW}	50			ns	
TSER, TSIG, Setup to TCLK, TSYSCLK Falling	t _{SU}	20			ns	
TSER, TSIG, Hold from TCLK, TSYSCLK Falling	t _{HD}	20			ns	
Delay TCLK to TCHBLK, TCHCLK, TSYNC	t _{D2}			50	ns	
Delay TSYSCLK to TCHCLK, TCHBLK	t _{D3}			50	ns	
Delay TCLK to TPOS, TNEG	t _{D4}			50	ns	

Note 1: T1 Mode.**Note 2:** E1 Mode.**Note 3:** RSYSCLK = 1.544MHz.**Note 4:** RSYSCLK = 2.048MHz.

Figure 13-8. Transmit Formatter Timing—Backplane

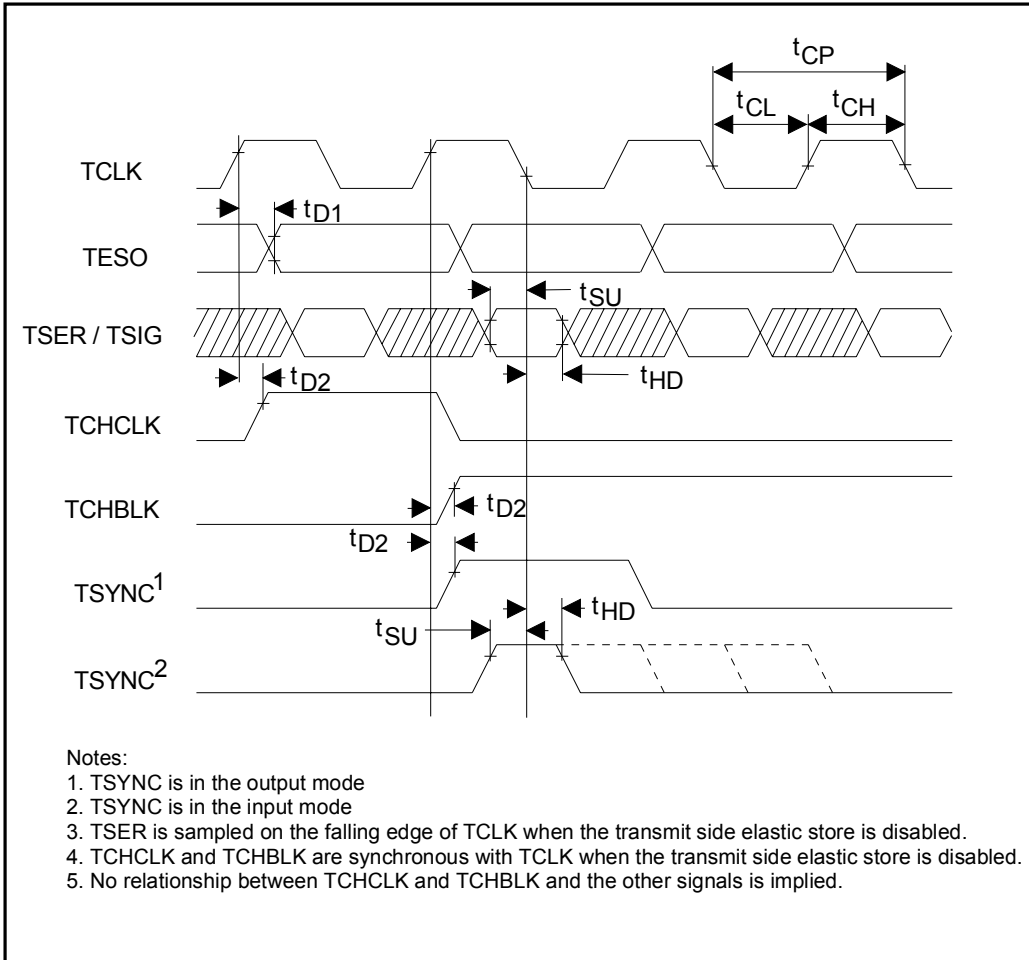


Figure 13-9. Transmit Formatter Timing, Elastic Store Enabled

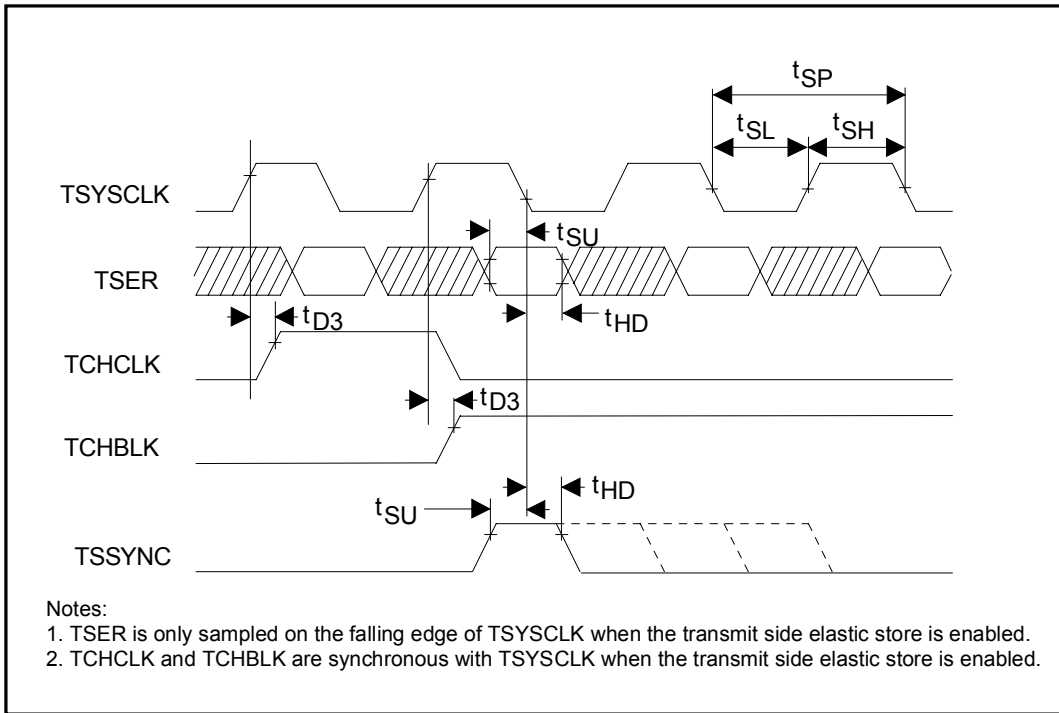
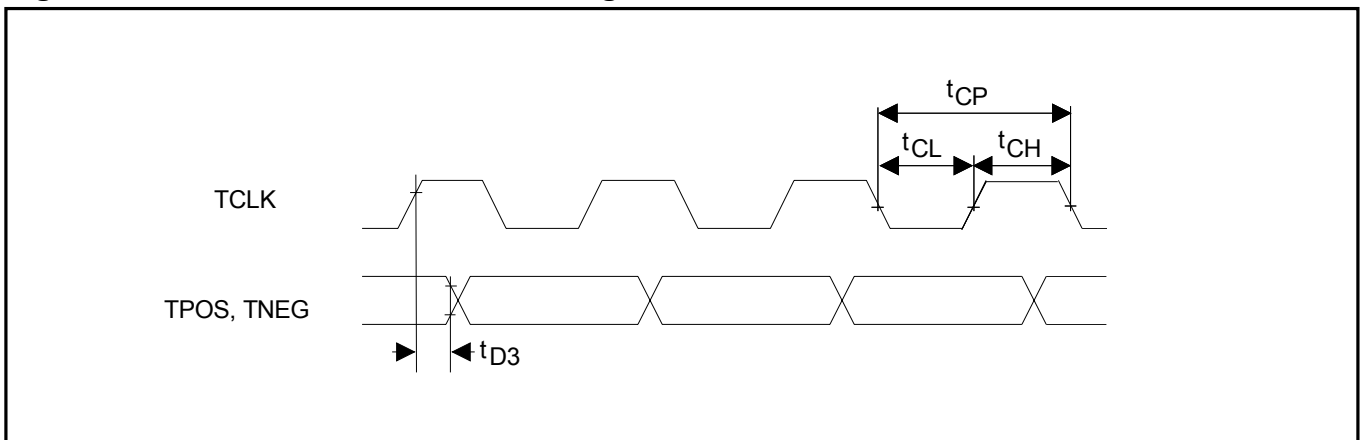


Figure 13-10. Transmit Formatter Timing—Line Side



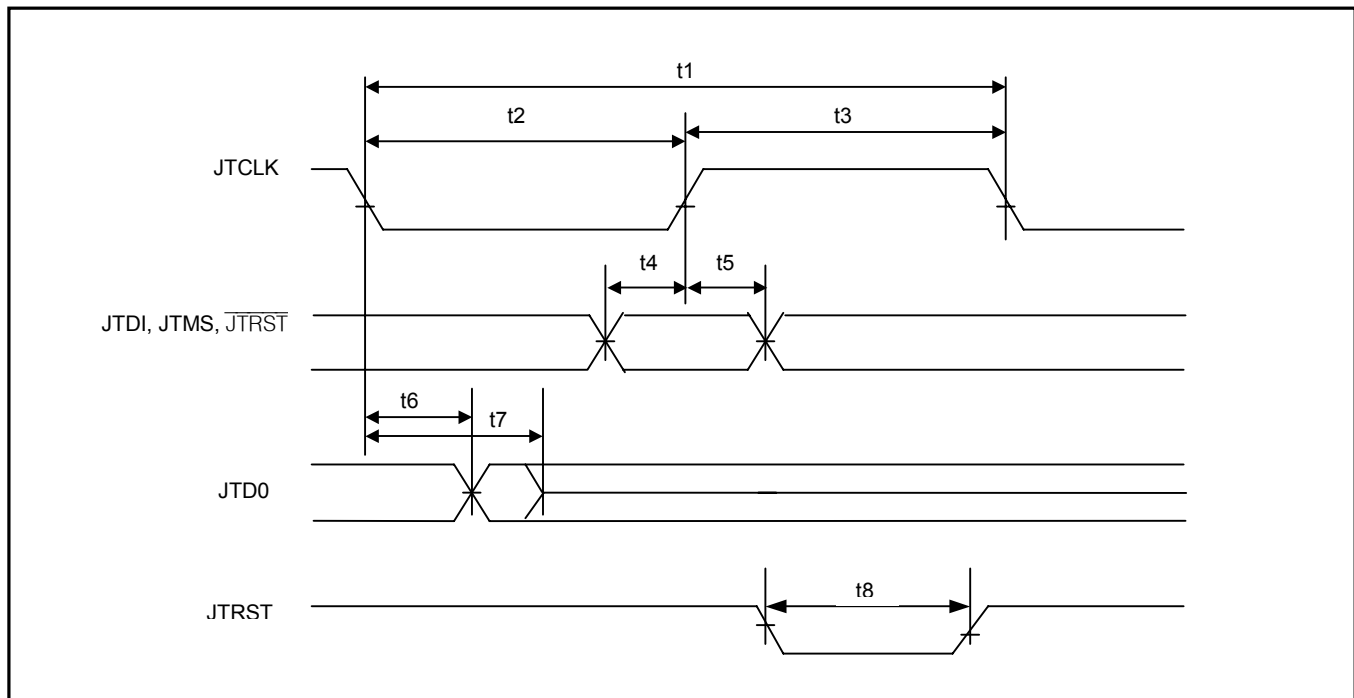
13.2 JTAG Interface Timing

($V_{DD} = 3.3V \pm 5\%$, $T_A = -40^\circ\text{C}$ to $+85^\circ\text{C}$.)

PARAMETER	SYMBOL	MIN	TYP	MAX	UNITS	NOTES
JTCLK Clock Period	t1		1000		ns	
JTCLK Clock High:Low Time	t2:t3	50	500		ns	1
JTCLK to JTDI, JTMS Setup Time	t4	5			ns	
JTCLK to JTDI, JTMS Hold Time	t5	2			ns	
JTCLK to JTDO Delay	t6	2		50	ns	
JTCLK to JTDO HIZ Delay	t7	2		50	ns	
$\overline{\text{JTRST}}$ Width Low Time	t8	100			ns	

Note 1: Clock can be stopped high or low.

Figure 13-11. JTAG Interface Timing Diagram



13.3 System Clock AC Characteristics

PARAMETER	SYMBOL	MIN	TYP	MAX	UNITS	NOTES
REF_CLK Frequency		1.544			MHz	
		2.048				
REF_CLK Duty Cycle		40		60	%	
Gapped Clock Frequency		43	45	60	MHz	1
Gapped Clock Duty Cycle		40		60	%	

Note 1: The gapped clock is output on the RCHCLK pin when [RESCLR](#).6=1.

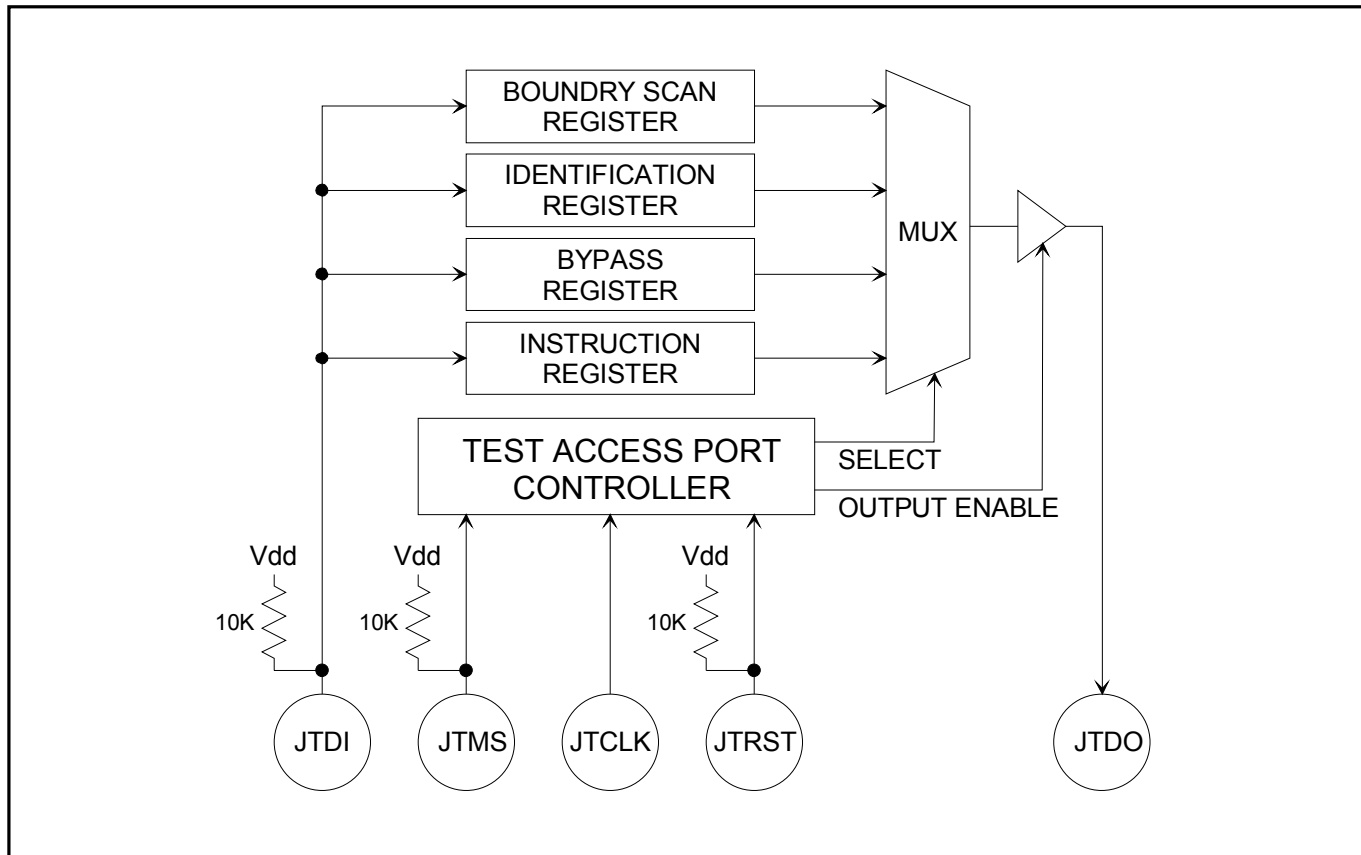
14. JTAG-BOUNDARY SCAN AND TEST ACCESS PORT

The DS26528 IEEE 1149.1 design supports the standard instruction codes SAMPLE:PRELOAD, BYPASS, and EXTEST. Optional public instructions included are HIGHZ, CLAMP, and IDCODE. See [Table 14-1](#). The DS26528 contains the following as required by IEEE 1149.1 Standard Test Access Port and Boundary Scan Architecture.

Test Access Port (TAP)
 TAP Controller
 Instruction Register
 Bypass Register
 Boundary Scan Register
 Device Identification Register

The Test Access Port has the necessary interface pins; JTRST, JTCLK, JTMS, JTDI, and JTDO. See the pin descriptions for details.

Figure 14-1. JTAG Functional Block Diagram



TAP CONTROLLER STATE MACHINE

The TAP controller is a finite state machine that responds to the logic level at JTMS on the rising edge of JTCLK. See [Figure 14-2](#).

Test-Logic-Reset

Upon power up, the TAP Controller will be in the Test-Logic-Reset state. The Instruction register will contain the IDCODE instruction. All system logic of the device will operate normally.

Run-Test-Idle

The Run-Test-Idle is used between scan operations or during specific tests. The Instruction register and test registers will remain idle.

Select-DR-Scan

All test registers retain their previous state. With JTMS LOW, a rising edge of JTCLK moves the controller into the Capture-DR state and will initiate a scan sequence. JTMS HIGH during a rising edge on JTCLK moves the controller to the Select-IR-Scan state.

Capture-DR

Data may be parallel-loaded into the test data registers selected by the current instruction. If the instruction does not call for a parallel load or the selected register does not allow parallel loads, the test register will remain at its current value. On the rising edge of JTCLK, the controller will go to the Shift-DR state if JTMS is LOW or it will go to the Exit1-DR state if JTMS is HIGH.

Shift-DR

The test data register selected by the current instruction will be connected between JTDI and JTDO and will shift data one stage towards its serial output on each rising edge of JTCLK. If a test register selected by the current instruction is not placed in the serial path, it will maintain its previous state.

Exit1-DR

While in this state, a rising edge on JTCLK will put the controller in the Update-DR state, which terminates the scanning process, if JTMS is HIGH. A rising edge on JTCLK with JTMS LOW will put the controller in the Pause-DR state.

Pause-DR

Shifting of the test registers is halted while in this state. All test registers selected by the current instruction will retain their previous state. The controller will remain in this state while JTMS is LOW. A rising edge on JTCLK with JTMS HIGH will put the controller in the Exit2-DR state.

Exit2-DR

A rising edge on JTCLK with JTMS HIGH while in this state will put the controller in the Update-DR state and terminate the scanning process. A rising edge on JTCLK with JTMS LOW will enter the Shift-DR state.

Update-DR

A falling edge on JTCLK while in the Update-DR state will latch the data from the shift register path of the test registers into the data output latches. This prevents changes at the parallel output due to changes in the shift register.

Select-IR-Scan

All test registers retain their previous state. The instruction register will remain unchanged during this state. With JTMS LOW, a rising edge on JTCLK moves the controller into the Capture-IR state and will initiate a scan sequence for the instruction register. JTMS HIGH during a rising edge on JTCLK puts the controller back into the Test-Logic-Reset state.

Capture-IR

The Capture-IR state is used to load the shift register in the instruction register with a fixed value. This value is loaded on the rising edge of JTCLK. If JTMS is HIGH on the rising edge of JTCLK, the controller will enter the Exit1-IR state. If JTMS is LOW on the rising edge of JTCLK, the controller will enter the Shift-IR state.

Shift-IR

In this state, the shift register in the instruction register is connected between JTDI and JTDO and shifts data one stage for every rising edge of JTCLK towards the serial output. The parallel register, as well as all test registers, remains at their previous states. A rising edge on JTCLK with JTMS HIGH will move the controller to the Exit1-IR state. A rising edge on JTCLK with JTMS LOW will keep the controller in the Shift-IR state while moving data one stage through the instruction shift register.

Exit1-IR

A rising edge on JTCLK with JTMS LOW will put the controller in the Pause-IR state. If JTMS is HIGH on the rising edge of JTCLK, the controller will enter the Update-IR state and terminate the scanning process.

Pause-IR

Shifting of the instruction shift register is halted temporarily. With JTMS HIGH, a rising edge on JTCLK will put the controller in the Exit2-IR state. The controller will remain in the Pause-IR state if JTMS is LOW during a rising edge on JTCLK.

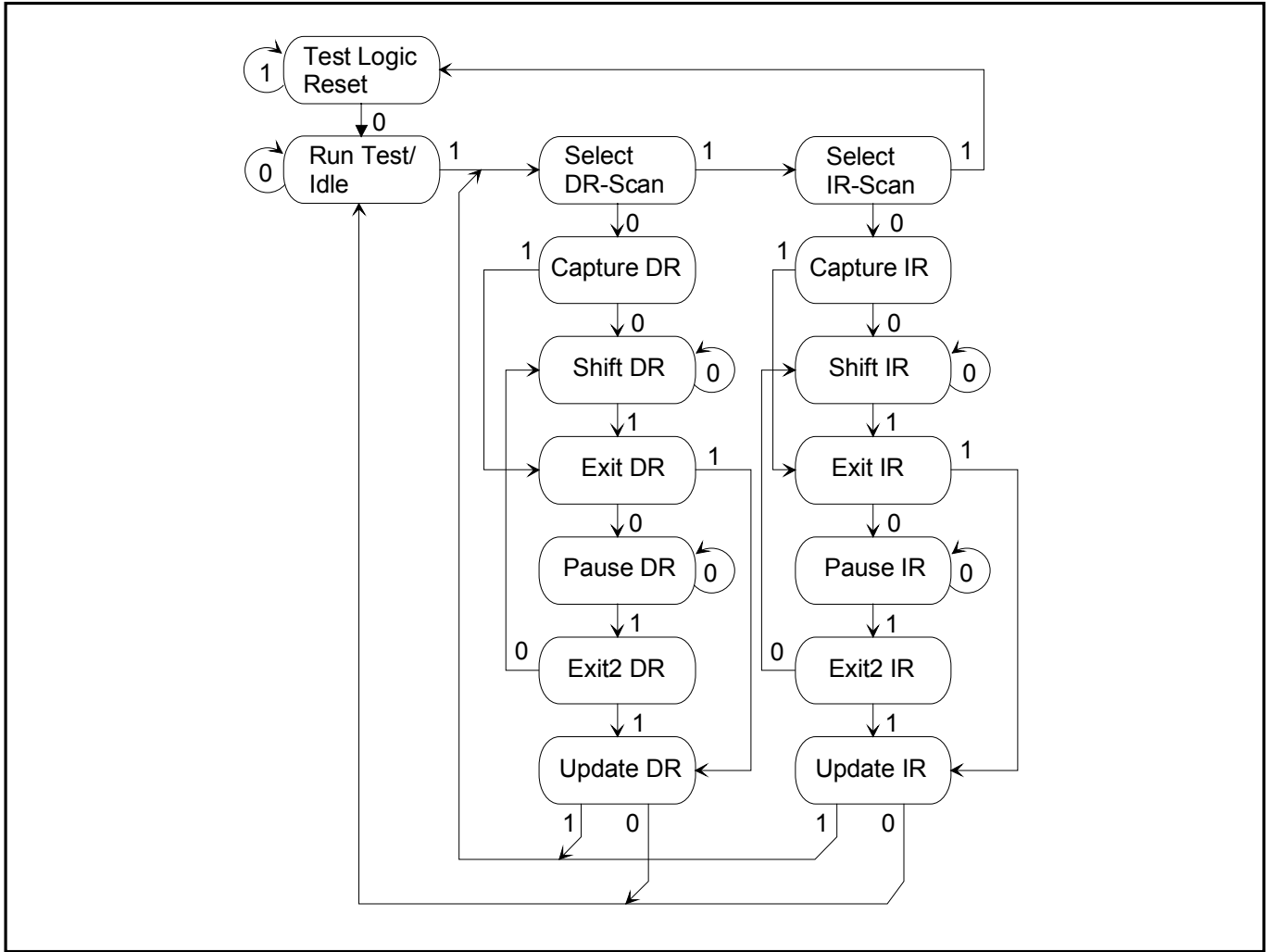
Exit2-IR

A rising edge on JTCLK with JTMS LOW will put the controller in the Update-IR state. The controller will loop back to Shift-IR if JTMS is HIGH during a rising edge of JTCLK in this state.

Update-IR

The instruction code shifted into the instruction shift register is latched into the parallel output on the falling edge of JTCLK as the controller enters this state. Once latched, this instruction becomes the current instruction. A rising edge on JTCLK with JTMS LOW, will put the controller in the Run-Test-Idle state. With JTMS HIGH, the controller will enter the Select-DR-Scan state.

Figure 14-2. Tap Controller State Diagram



14.1 Instruction Register

The instruction register contains a shift register as well as a latched parallel output and is 3 bits in length. When the TAP controller enters the Shift-IR state, the instruction shift register will be connected between JTDI and JTDO. While in the Shift-IR state, a rising edge on JTCLK with JTMS LOW will shift the data one stage towards the serial output at JTDO. A rising edge on JTCLK in the Exit1-IR state or the Exit2-IR state with JTMS HIGH will move the controller to the Update-IR state. The falling edge of that same JTCLK will latch the data in the instruction shift register to the instruction parallel output. Instructions supported by the DS26528 and its respective operational binary codes are shown in [Table 14-1](#).

Table 14-1. Instruction Codes for IEEE 1149.1 Architecture

INSTRUCTION	SELECTED REGISTER	INSTRUCTION CODES
SAMPLE:PRELOAD	Boundary Scan	010
BYPASS	Bypass	111
EXTEST	Boundary Scan	000
CLAMP	Bypass	011
HIGHZ	Bypass	100
IDCODE	Device Identification	001

SAMPLE:PRELOAD

This is a mandatory instruction for the IEEE 1149.1 specification. This instruction supports two functions. The digital I/Os of the device can be sampled at the boundary scan register without interfering with the normal operation of the device by using the Capture-DR state. SAMPLE:PRELOAD also allows the device to shift data into the boundary scan register via JTDI using the Shift-DR state.

BYPASS

When the BYPASS instruction is latched into the parallel instruction register, JTDI connects to JTDO through the one-bit bypass test register. This allows data to pass from JTDI to JTDO not affecting the device's normal operation.

EXTEST

This allows testing of all interconnections to the device. When the EXTEST instruction is latched in the instruction register, the following actions occur. Once enabled via the Update-IR state, the parallel outputs of all digital output pins will be driven. The boundary scan register will be connected between JTDI and JTDO. The Capture-DR will sample all digital inputs into the boundary scan register.

CLAMP

All digital outputs of the device will output data from the boundary scan parallel output while connecting the bypass register between JTDI and JTDO. The outputs will not change during the CLAMP instruction.

HIGHZ

All digital outputs of the device will be placed in a high impedance state. The BYPASS register will be connected between JTDI and JTDO.

IDCODE

When the IDCODE instruction is latched into the parallel instruction register, the identification test register is selected. The device identification code will be loaded into the identification register on the rising edge of JTCLK following entry into the Capture-DR state. Shift-DR can be used to shift the identification code out serially via JTDO. During Test-Logic-Reset, the identification code is forced into the instruction register's parallel output. The ID code will always have a '1' in the LSB position. The next 11 bits identify the manufacturer's JEDEC number and number of continuation bytes followed by 16 bits for the device and 4 bits for the version.

14.2 JTAG ID Codes

Table 14-2. ID Code Structure

DEVICE	REVISION ID[31:28]	DEVICE CODE ID[27:12]	MANUFACTURER'S CODE ID[11:1]	REQUIRED ID[0]
DS26528	Consult factory	0000000000110111	00010100001	1
DS26524	Consult factory	0000000000111001	00010100001	1

14.3 Test Registers

IEEE 1149.1 requires a minimum of two test registers; the bypass register and the boundary scan register. An optional test register has been included with the DS26528 design. This test register is the identification register and is used in conjunction with the IDCODE instruction and the Test-Logic-Reset state of the TAP controller.

14.4 Boundary Scan Register

This register contains both a shift register path and a latched parallel output for all control cells and digital I/O cells and is n bits in length. See [Table 14-3](#) for all of the cell bit locations and definitions.

14.5 Bypass Register

This is a single one-bit shift register used in conjunction with the BYPASS, CLAMP, and HIGHZ instructions, which provides a short path between JTDI and JTDO.

14.6 Identification Register

The identification register contains a 32-bit shift register and a 32-bit latched parallel output. This register is selected during the IDCODE instruction and when the TAP controller is in the Test-Logic-Reset state.

Table 14-3. Boundary Scan Control Bits

CELL#	NAME	TYPE	CONTROL CELL
0	—	controlr	
1	rser(1)	output3	0
2	—	controlr	
3	rm_rfsync(1)	output3	2
4	rm_rfsync(1)	observe_only	
5	—	controlr	
6	rsync(1)	output3	5
7	rsync(1)	observe_only	
8	—	controlr	
9	tsig(1)	output3	8
10	tsig(1)	observe_only	
11	—	controlr	
12	tsync(1)	output3	11
13	tsync(1)	observe_only	
14	tser(1)	observe_only	
15	tclk(1)	observe_only	
16	—	controlr	
17	tchblk_clk(1)	output3	16
18	tchblk_clk(1)	observe_only	

CELL#	NAME	TYPE	CONTROL CELL
19	—	controlr	
20	rchblk_clk(2)	output3	19
21	rchblk_clk(2)	observe_only	
22	—	controlr	
23	rsig(2)	output3	22
24	rsig(2)	observe_only	
25	—	controlr	
26	rfl_ttc(2)	output3	25
27	—	controlr	
28	al_rsig_flos(2)	output3	27
29	—	controlr	
30	rser(2)	output3	29
31	—	controlr	
32	rm_rfsync(2)	output3	31
33	rm_rfsync(2)	observe_only	
34	—	controlr	
35	rsync(2)	output3	34
36	rsync(2)	observe_only	
37	—	controlr	

CELL#	NAME	TYPE	CONTROL CELL
38	tsig(2)	output3	37
39	tsig(2)	observe_only	
40	—	controlr	
41	tsync(2)	output3	40
42	tsync(2)	observe_only	
43	tser(2)	observe_only	
44	tclk(2)	observe_only	
45	—	controlr	
46	tchblk_clk(2)	output3	45
47	tchblk_clk(2)	observe_only	
48	mclk	observe_only	
49	—	controlr	
50	refclkio	output3	49
51	refclkio	observe_only	
52	—	controlr	
53	bpclk	output3	52
54	a(12)	observe_only	
55	a(11)	observe_only	
56	a(10)	observe_only	
57	digio_en	observe_only	
58	a(9)	observe_only	
59	a(8)	observe_only	
60	a(7)	observe_only	
61	a(6)	observe_only	
62	a(5)	observe_only	
63	a(4)	observe_only	
64	a(3)	observe_only	
65	a(2)	observe_only	
66	a(1)	observe_only	
67	a(0)	observe_only	
68	—	controlr	
69	tchblk_clk(7)	output3	68
70	tchblk_clk(7)	observe_only	
71	tclk(7)	observe_only	
72	tser(7)	observe_only	
73	—	controlr	
74	tsync(7)	output3	73
75	tsync(7)	observe_only	
76	—	controlr	
77	tsig(7)	output3	76
78	tsig(7)	observe_only	
79	—	controlr	

CELL#	NAME	TYPE	CONTROL CELL
80	rsync(7)	output3	79
81	rsync(7)	observe_only	
82	—	controlr	
83	rm_rfsync(7)	output3	82
84	rm_rfsync(7)	observe_only	
85	—	controlr	
86	rser(7)	output3	85
87	—	controlr	
88	al_rsigf_flos(7)	output3	87
89	—	controlr	
90	rfl_ttc(7)	output3	89
91	—	controlr	
92	rsig(7)	output3	91
93	rsig(7)	observe_only	
94	—	controlr	
95	rchblk_clk(7)	output3	94
96	rchblk_clk(7)	observe_only	
97	—	controlr	
98	tchblk_clk(8)	output3	97
99	tchblk_clk(8)	observe_only	
100	tclk(8)	observe_only	
101	tser(8)	observe_only	
102	—	controlr	
103	tsync(8)	output3	102
104	tsync(8)	observe_only	
105	—	controlr	
106	tsig(8)	output3	105
107	tsig(8)	observe_only	
108	—	controlr	
109	rsync(8)	output3	108
110	rsync(8)	observe_only	
111	—	controlr	
112	rm_rfsync(8)	output3	111
113	rm_rfsync(8)	observe_only	
114	—	controlr	
115	rser(8)	output3	114
116	—	controlr	
117	al_rsigf_flos(8)	output3	116
118	—	controlr	
119	rfl_ttc(8)	output3	118
120	—	controlr	
121	rclk(8)	output3	120

CELL#	NAME	TYPE	CONTROL CELL
122	rclk(8)	observe_only	
123	—	controlr	
124	rclk(7)	output3	123
125	rclk(7)	observe_only	
126	—	controlr	
127	rsig(8)	output3	126
128	rsig(8)	observe_only	
129	—	controlr	
130	rchblk_clk(8)	output3	129
131	rchblk_clk(8)	observe_only	
132	—	controlr	
133	rclk(6)	output3	132
134	rclk(6)	observe_only	
135	—	controlr	
136	rclk(5)	output3	135
137	rclk(5)	observe_only	
138	resetb	observe_only	
139	txen_b	observe_only	
140	bts	observe_only	
141	rsysclk	observe_only	
142	—	controlr	
143	tssyncio	output3	142
144	tssyncio	observe_only	
145	tsysclk	observe_only	
146	—	controlr	
147	rchblk_clk(6)	output3	146
148	rchblk_clk(6)	observe_only	
149	—	controlr	
150	rsig(6)	output3	149
151	rsig(6)	observe_only	
152	—	controlr	
153	rfl_ltc(6)	output3	152
154	—	controlr	
155	al_rsig_flos(6)	output3	154
156	—	controlr	
157	rser(6)	output3	156
158	—	controlr	
159	rm_rfsync(6)	output3	158
160	rm_rfsync(6)	observe_only	
161	—	controlr	
162	rsync(6)	output3	161
163	rsync(6)	observe_only	

CELL#	NAME	TYPE	CONTROL CELL
164	—	controlr	
165	tsig(6)	output3	164
166	tsig(6)	observe_only	
167	—	controlr	
168	tsync(6)	output3	167
169	tsync(6)	observe_only	
170	tser(6)	observe_only	
171	tclk(6)	observe_only	
172	—	controlr	
173	tchblk_clk(6)	output3	172
174	tchblk_clk(6)	observe_only	
175	—	controlr	
176	rchblk_clk(5)	output3	175
177	rchblk_clk(5)	observe_only	
178	—	controlr	
179	rsig(5)	output3	178
180	rsig(5)	observe_only	
181	—	controlr	
182	rfl_ltc(5)	output3	181
183	—	controlr	
184	al_rsig_flos(5)	output3	183
185	—	controlr	
186	rser(5)	output3	185
187	—	controlr	
188	rm_rfsync(5)	output3	187
189	rm_rfsync(5)	observe_only	
190	—	controlr	
191	rsync(5)	output3	190
192	rsync(5)	observe_only	
193	—	controlr	
194	tsig(5)	output3	193
195	tsig(5)	observe_only	
196	—	controlr	
197	tsync(5)	output3	196
198	tsync(5)	observe_only	
199	tser(5)	observe_only	
200	tclk(5)	observe_only	
201	—	controlr	
202	tchblk_clk(5)	output3	201
203	tchblk_clk(5)	observe_only	
204	—	controlr	
205	intb	output3	204

CELL#	NAME	TYPE	CONTROL CELL
206	d(7)	output3	220
207	d(7)	observe_only	
208	d(6)	output3	220
209	d(6)	observe_only	
210	d(5)	output3	220
211	d(5)	observe_only	
212	d(4)	output3	220
213	d(4)	observe_only	
214	d(3)	output3	220
215	d(3)	observe_only	
216	d(2)	output3	220
217	d(2)	observe_only	
218	d(1)	output3	220
219	d(1)	observe_only	
220	—	controlr	
221	d(0)	output3	220
222	d(0)	observe_only	
223	rdb_dsb	observe_only	
224	wrb_rwb	observe_only	
225	csb	observe_only	
226	—	controlr	
227	tchblk_clk(4)	output3	226
228	tchblk_clk(4)	observe_only	
229	tclk(4)	observe_only	
230	tser(4)	observe_only	
231	—	controlr	
232	tsync(4)	output3	231
233	tsync(4)	observe_only	
234	—	controlr	
235	tsig(4)	output3	234
236	tsig(4)	observe_only	
237	—	controlr	
238	rsync(4)	output3	237
239	rsync(4)	observe_only	
240	—	controlr	
241	rm_rfsync(4)	output3	240
242	rm_rfsync(4)	observe_only	
243	—	controlr	
244	rser(4)	output3	243
245	—	controlr	
246	al_rsigf_flos(4)	output3	245
247	—	controlr	

CELL#	NAME	TYPE	CONTROL CELL
248	rif_ltc(4)	output3	247
249	—	controlr	
250	rsig(4)	output3	249
251	rsig(4)	observe_only	
252	—	controlr	
253	rchblk_clk(4)	output3	252
254	rchblk_clk(4)	observe_only	
255	—	controlr	
256	tchblk_clk(3)	output3	255
257	tchblk_clk(3)	observe_only	
258	tclk(3)	observe_only	
259	tser(3)	observe_only	
260	—	controlr	
261	tsync(3)	output3	260
262	tsync(3)	observe_only	
263	—	controlr	
264	tsig(3)	output3	263
265	tsig(3)	observe_only	
266	—	controlr	
267	rsync(3)	output3	266
268	rsync(3)	observe_only	
269	—	controlr	
270	rm_rfsync(3)	output3	269
271	rm_rfsync(3)	observe_only	
272	—	controlr	
273	rser(3)	output3	272
274	—	controlr	
275	al_rsigf_flos(3)	output3	274
276	—	controlr	
277	rif_ltc(3)	output3	276
278	—	controlr	
279	rsig(3)	output3	278
280	rsig(3)	observe_only	
281	—	controlr	
282	rchblk_clk(3)	output3	281
283	rchblk_clk(3)	observe_only	
284	—	controlr	
285	rclk(4)	output3	284
286	rclk(4)	observe_only	
287	—	controlr	
288	rclk(3)	output3	287
289	rclk(3)	observe_only	

CELL#	NAME	TYPE	CONTROL CELL
290	—	controlr	
291	rclk(2)	output3	290
292	rclk(2)	observe_only	
293	—	controlr	
294	rclk(1)	output3	293
295	rclk(1)	observe_only	
296	—	controlr	
297	rchblk_clk(1)	output3	296

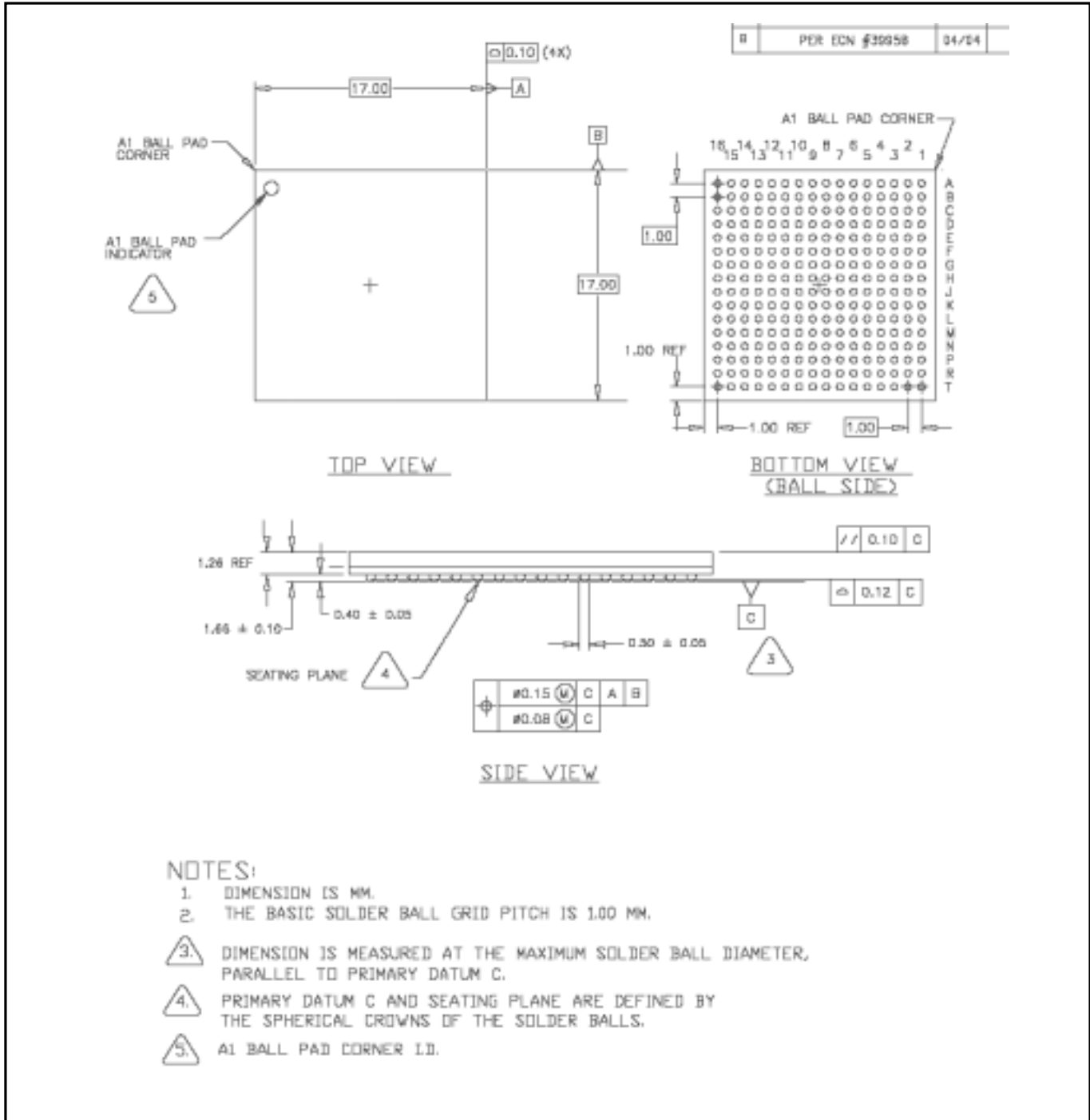
CELL#	NAME	TYPE	CONTROL CELL
298	rchblk_clk(1)	observe_only	
299	—	controlr	
300	rsig(1)	output3	299
301	rsig(1)	observe_only	
302	—	controlr	
303	rfl_ltc(1)	output3	302
304	—	controlr	
305	al_rsig_flos(1)	output3	304

15. DOCUMENT REVISION HISTORY

REVISION	DESCRIPTION
072304	New Product Release.

16. PACKAGE INFORMATION

(The package drawing(s) in this data sheet may not reflect the most current specifications. For the latest package outline information, go to www.maxim-ic.com/DallasPackInfo.)



NOTES:

1. DIMENSION IS MM.
2. THE BASIC SOLDER BALL GRID PITCH IS 1.00 MM.
3. DIMENSION IS MEASURED AT THE MAXIMUM SOLDER BALL DIAMETER, PARALLEL TO PRIMARY DATUM C.
4. PRIMARY DATUM C AND SEATING PLANE ARE DEFINED BY THE SPHERICAL CROWNS OF THE SOLDER BALLS.
5. A1 BALL PAD CORNER I.D.

Maxim/Dallas Semiconductor cannot assume responsibility for use of any circuitry other than circuitry entirely embodied in a Maxim/Dallas Semiconductor product. No circuit patent licenses are implied. Maxim/Dallas Semiconductor reserves the right to change the circuitry and specifications without notice at any time.

Maxim Integrated Products, 120 San Gabriel Drive, Sunnyvale, CA 94086 408-737-7600

© 2004 Maxim Integrated Products • Printed USA