



+3.0V to +5.5V, 1.25Gbps/2.5Gbps Limiting Amplifiers

General Description

The 1.25Gbps MAX3264/MAX3268/MAX3768 and the 2.5Gbps MAX3265/MAX3269/MAX3765 limiting amplifiers are designed for Gigabit Ethernet and Fibre Channel optical receiver systems. The amplifiers accept a wide range of input voltages and provide constant-level output voltages with controlled edge speeds. Additional features include RMS power detectors with programmable loss-of-signal (LOS) indication, an optional squelch function that mutes the data output signal when the input voltage falls below a programmable threshold, and excellent jitter performance.

The MAX3264/MAX3265/MAX3765 feature current-mode logic (CML) data outputs that are tolerant of inductive connectors and a 16-pin TSSOP package, making these circuits ideal for GBIC receivers. The MAX3268/MAX3269/MAX3768 feature standards-compliant positive-referenced emitter-coupled logic (PECL) data outputs and are available in a tiny 10-pin μ MAX package that is ideal for small-form-factor (SFF) receivers.

Applications

- Gigabit Ethernet Optical Receivers
- Fibre Channel Optical Receivers
- System Interconnect
- ATM Optical Receivers

Selector Guide appears at end of data sheet.
Pin Configurations appear at end of data sheet.

Features

- ◆ +3.0V to +5.5V Supply Voltage
- ◆ Low Deterministic Jitter
 14ps (MAX3264)
 11ps (MAX3265/MAX3765)
- ◆ 150ps (max) Edge Speed (MAX3265/MAX3765)
 300ps (max) Edge Speed (MAX3264)
- ◆ Programmable Signal-Detect Function
- ◆ Choice of CML or PECL Output Interface
- ◆ 10-Pin μ MAX or 16-Pin TSSOP Package

Ordering Information

PART	TEMP RANGE	PIN-PACKAGE
MAX3264 CUE	0°C to +70°C	16 TSSOP-EP [†]
MAX3264C/D	0°C to +70°C	Dice*
MAX3265 CUE	0°C to +70°C	16 TSSOP-EP [†]
MAX3265CUB	0°C to +70°C	10 μ MAX-EP [†]
MAX3265C/D	0°C to +70°C	Dice*
MAX3265EUE	-40°C to +85°C	16 TSSOP-EP [†]
MAX3268 CUB	0°C to +70°C	10 μ MAX-EP [†]
MAX3268C/D	0°C to +70°C	Dice*
MAX3269 CUB	0°C to +70°C	10 μ MAX-EP [†]
MAX3269C/D	0°C to +70°C	Dice*
MAX3765 CUB	0°C to +70°C	10 μ MAX-EP [†]
MAX3768 CUB	0°C to +70°C	10 μ MAX-EP [†]

*Dice are designed to operate from 0°C to +70°C, but are tested and guaranteed only at $T_A = +25^\circ\text{C}$.

[†]EP = Exposed paddle.

Typical Operating Circuits

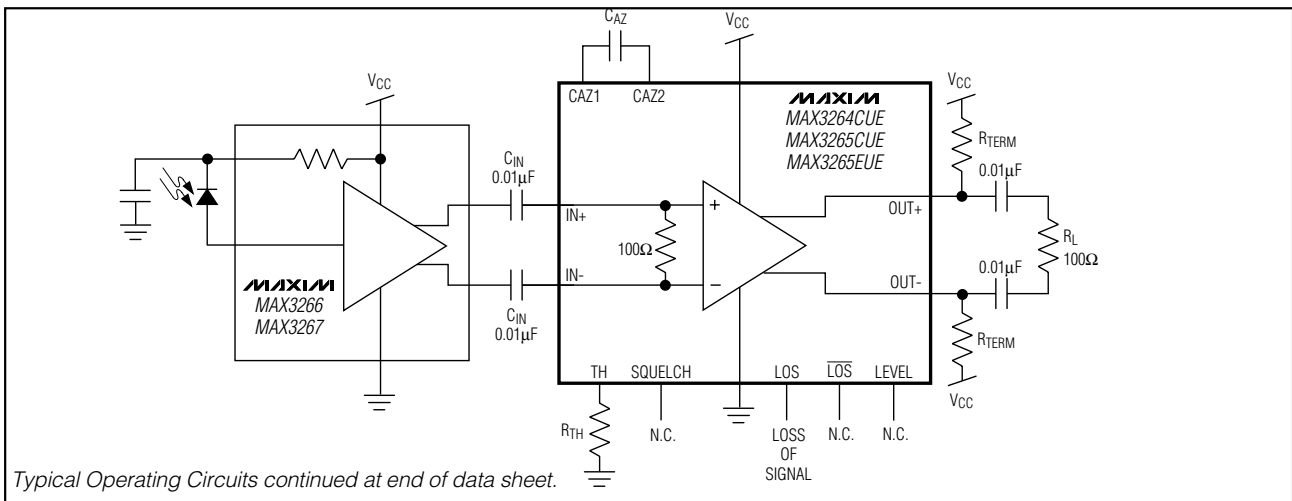

MAX3264/MAX3265/MAX3268/MAX3269/MAX3765/MAX3768



+3.0V to +5.5V, 1.25Gbps/2.5Gbps Limiting Amplifiers

ABSOLUTE MAXIMUM RATINGS

Supply Voltage (V _{CC})	-0.5V to +6.0V	Continuous Current at PECL Outputs (OUT+, OUT-)	50mA
Voltage at IN+, IN-	(V _{CC} - 2.4V) to (V _{CC} + 0.5V)	Continuous Power Dissipation (T _A = +70°C)	
Voltage at SQUELCH, CAZ1, CAZ2, LOS, LOS, TH	-0.5V to (V _{CC} + 0.5V)	16-Pin TSSOP (derate 27mW/°C above +70°C)	2162mW
Voltage at LEVEL	-0.5V to +2.0V	10-Pin μMAX (derate 20mW/°C above +70°C)	1600mW
Current into LOS, LOS	-1mA to +9mA	Operating Ambient Temperature Range	-40°C to +85°C
Differential Input Voltage (IN+ - IN-)	2.5V	Storage Temperature Range	-55°C to +150°C
Continuous Current at CML Outputs (OUT+, OUT-)	-25mA to +25mA	Processing Temperature (dice)	+400°C
		Lead Temperature (soldering, 10s)	+300°C

Stresses beyond those listed under "Absolute Maximum Ratings" may cause permanent damage to the device. These are stress ratings only, and functional operation of the device at these or any other conditions beyond those indicated in the operational sections of the specifications is not implied. Exposure to absolute maximum rating conditions for extended periods may affect device reliability.

ELECTRICAL CHARACTERISTICS

(Data outputs terminated per Figure 1, V_{CC} = +3.0V to +5.5V, T_A = 0°C to +70°C. Typical values are at V_{CC} = +3.3V, T_A = +25°C, unless otherwise noted.) (Note 1)

PARAMETER	CONDITIONS		MIN	TYP	MAX	UNITS
Data Rate	MAX3264/MAX3268/MAX3768		1.25			Gbps
	MAX3265/MAX3269/MAX3765		2.5			
Input Voltage Range	MAX3264/MAX3268/MAX3768		5		1200	mV
	MAX3265/MAX3269/MAX3765		10		1200	
Deterministic Jitter	MAX3264/MAX3268/MAX3768 (Notes 2, 3)			14	30	psp-p
	MAX3265/MAX3269/MAX3765 (Notes 2, 3)			11	25	
Random Jitter	MAX3264/MAX3268/MAX3768 (Notes 2, 4)			15		psRMS
	MAX3265/MAX3269/MAX3765 (Notes 2, 4)			8		
Data Output Edge Speed	MAX3264 (Note 5)		80	175	300	ps
	MAX3265/MAX3765 (Note 6)			100	150	
	MAX3268/MAX3768 (Note 5)		80	150	300	
	MAX3269 (Note 6)			100	150	
LOS Hysteresis	(Notes 2, 7)		2.5	4.4		dB
LOS Assert/Deassert Time	(Notes 7, 8)			1		μs
Low LOS Assert Level	R _{TH} = 2.5kΩ	MAX3264/MAX3268/MAX3768	1.20	2.6		mV
		MAX3265/MAX3269/MAX3765	2.20	4.8		
Low LOS Deassert Level	R _{TH} = 2.5kΩ	MAX3264/MAX3268/MAX3768		4.5		mV
		MAX3265/MAX3269/MAX3765		8.5		

+3.0V to +5.5V, 1.25Gbps/2.5Gbps Limiting Amplifiers

ELECTRICAL CHARACTERISTICS (continued)

(Data outputs terminated per Figure 1, $V_{CC} = +3.0V$ to $+5.5V$, $T_A = 0^{\circ}C$ to $+70^{\circ}C$. Typical values are at $V_{CC} = +3.3V$, $T_A = +25^{\circ}C$, unless otherwise noted.) (Note 1)

PARAMETER	CONDITIONS		MIN	TYP	MAX	UNITS
Medium LOS Assert Level	$R_{TH} = 7k\Omega$	MAX3264/MAX3268/MAX3768	5.6	9		mV
		MAX3265/MAX3269/MAX3765	9.9	16		
Medium LOS Deassert Level	$R_{TH} = 7k\Omega$	MAX3264/MAX3268/MAX3768		15	19.8	mV
		MAX3265/MAX3269/MAX3765		27	40.5	
High LOS Assert Level	$R_{TH} = 20k\Omega$	MAX3264/MAX3268/MAX3768	9.4	21.6		mV
		MAX3265/MAX3269/MAX3765	18.0	41.5		
High LOS Deassert Level	$R_{TH} = 20k\Omega$	MAX3264/MAX3268/MAX3768		35		mV
		MAX3265/MAX3269/MAX3765		67		
Squelch Input Current			0	80	400	μA
Differential Input Resistance	$IN+$ to $IN-$		97	100	103	Ω
Input-Referred Noise	MAX3264/MAX3268/MAX3768		150			μV_{RMS}
	MAX3265/MAX3269/MAX3765		230			
CML Output Voltage	LEVEL = open, $R_{LOAD} = 50\Omega$		550		1200	mV
	LEVEL = GND, $R_{LOAD} = 75\Omega$		1100	1270	1800	
PECL Output High Voltage	Referenced to V_{CC}		-1.025		-0.880	V
PECL Output Low Voltage	Referenced to V_{CC}		-1.810		+1.620	V
LOS Output High Voltage	$I_{LOS} = -30\mu A$		2.4			V
LOS Output Low Voltage	$I_{LOS} = +1.2mA$				0.4	V
Output Signal When Squelched	Outputs AC-coupled			20		mV
Power-Supply Rejection Ratio	$f < 2MHz$			20		dB
Low-Frequency Cutoff	$C_{AZ} = open$			2		MHz
	$C_{AZ} = 0.1\mu F$			2		kHz
Output Resistance (Single Ended)	MAX3264/MAX3265/MAX3765		85	100	115	Ω
	MAX3268/MAX3269/MAX3768			4		
Power-Supply Current	Figure 2		MAX3268	39	62	mA
			MAX3269	48	78	
		Output not squelched	MAX3264	38	62	
			MAX3265	50	76	
			MAX3765	50	76	
			MAX3768	39	62	
		Output squelched	MAX3765	64	90	

MAX3264/MAX3265/MAX3268/MAX3269/MAX3765/MAX3768

+3.0V to +5.5V, 1.25Gbps/2.5Gbps Limiting Amplifiers

ELECTRICAL CHARACTERISTICS—MAX3265EUE

(Data outputs terminated per Figure 1, $V_{CC} = +3.0V$ to $+5.5V$, $T_A = -40^{\circ}C$ to $+85^{\circ}C$. Typical values are at $V_{CC} = +3.3V$, $T_A = +25^{\circ}C$, unless otherwise noted.) (Note 1)

PARAMETER	CONDITIONS	MIN	TYP	MAX	UNITS
Data Rate			2.5		Gbps
Input Voltage Range		10		1200	mV
Deterministic Jitter	(Notes 2, 3)		11	25	ps _{p-p}
Random Jitter	(Notes 2, 4)		8		ps _{RMS}
Data Output Edge Speed	(Note 6)		100	155	ps
LOS Hysteresis	(Notes 2, 7)	2.2	4.4		dB
LOS Assert/Deassert Time	(Notes 7, 8)		1		μs
Low LOS Assert Level	$R_{TH} = 2.5k\Omega$	2.20	4.8		mV
Low LOS Deassert Level	$R_{TH} = 2.5k\Omega$		8.5	13.6	mV
Medium LOS Assert Level	$R_{TH} = 7k\Omega$	9.9	16		mV
Medium LOS Deassert Level	$R_{TH} = 7k\Omega$		27	43.0	mV
High LOS Assert Level	$R_{TH} = 20k\Omega$	18.0	41.5		mV
High LOS Deassert Level	$R_{TH} = 20k\Omega$		67	111	mV
Squelch Input Current		0	80	400	μA
Differential Input Resistance	IN+ to IN-	97	100	103	Ω
Input-Referred Noise			230		μV _{RMS}
CML Output Voltage	LEVEL = open, $R_{LOAD} = 50\Omega$	550		1200	mV
	LEVEL = GND, $R_{LOAD} = 75\Omega$	1100	1270	1800	
LOS Output High Voltage	$I_{LOS} = -30\mu A$	2.4			V
LOS Output Low Voltage	$I_{LOS} = +1.2mA$			0.450	V
Output Signal When Squelched	Outputs AC-coupled		20		mV
Power-Supply Rejection Ratio	$f < 2MHz$		20		dB
Low-Frequency Cutoff	$C_{AZ} = open$		2		MHz
	$C_{AZ} = 0.1\mu F$		2		kHz
Output Resistance (single ended)		85	100	115	Ω
Power-Supply Current	Figure 2		50	76	mA

Note 1: Specifications for Input Voltage Range, LOS Assert/Deassert Levels, and CML Output Voltage refer to the total differential peak-to-peak signal applied or measured. PECL output voltages are absolute (single-ended) voltages measured at a single output.

Note 2: Input edge speed is controlled using four-pole, lowpass Bessel filters with bandwidth approximately 75% of the maximum data rate.

Note 3: Deterministic jitter is measured with a K28.5 pattern (0011 1110 1011 0000 0101). Deterministic jitter is the peak-to-peak deviation from ideal time crossings, measured at the zero-level crossings of the differential output per ANSI X3.230, Annex A.

Note 4: Random jitter is measured with the minimum input signal applied after filtering with a four-pole, lowpass, Bessel filter (frequency bandwidth at 75% of the maximum data rate). For Fibre Channel and Gigabit Ethernet applications, the peak-to-peak random jitter is 14.1-times the RMS random jitter.

Note 5: Input signal applied after a 933MHz Bessel filter.

Note 6: Input signal applied after a 1.8GHz Bessel filter.

Note 7: Input for LOS assert/deassert and hysteresis tests is a repeating K28.5 pattern. Hysteresis is defined as: $20\log(V_{LOS-DEASSERT} / V_{LOS-ASSERT})$.

Note 8: Response time to a 10dB change in input power.

+3.0V to +5.5V, 1.25Gbps/2.5Gbps Limiting Amplifiers

Typical Operating Characteristics

($T_A = +25^\circ\text{C}$, unless otherwise noted.)

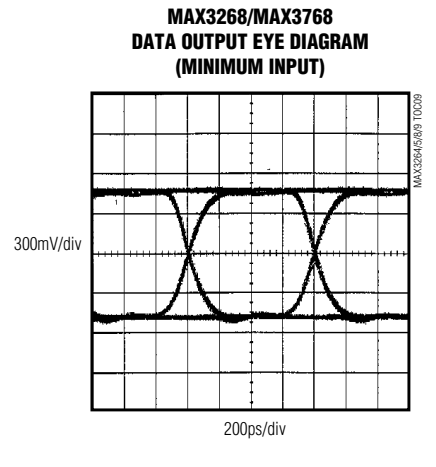
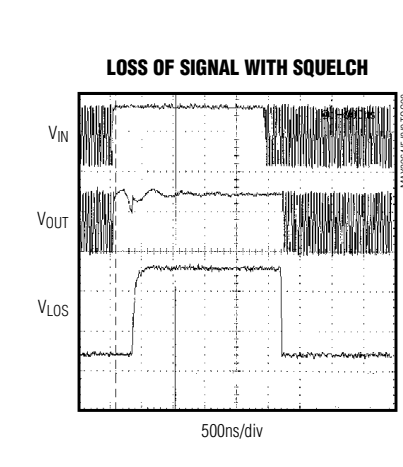
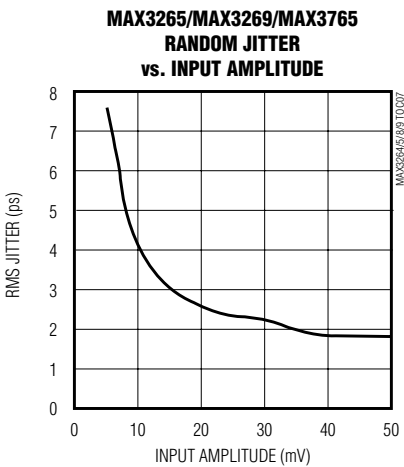
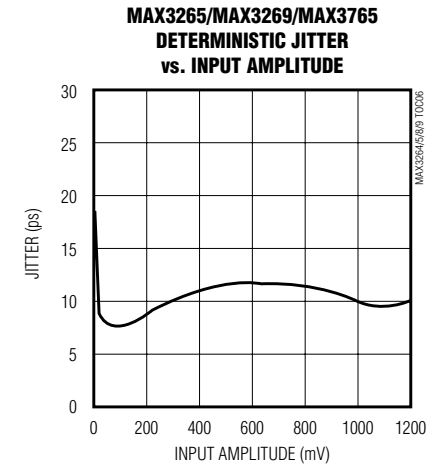
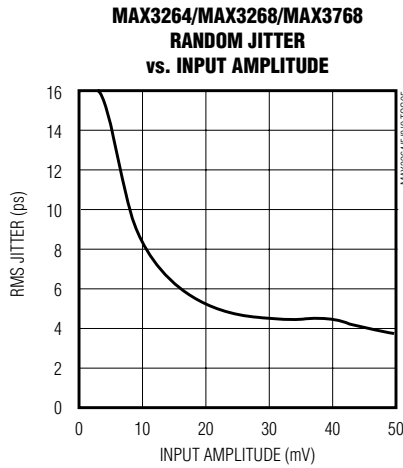
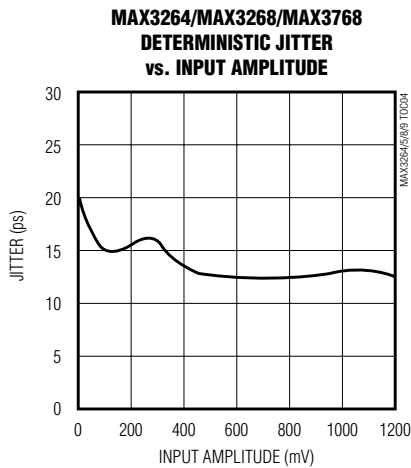
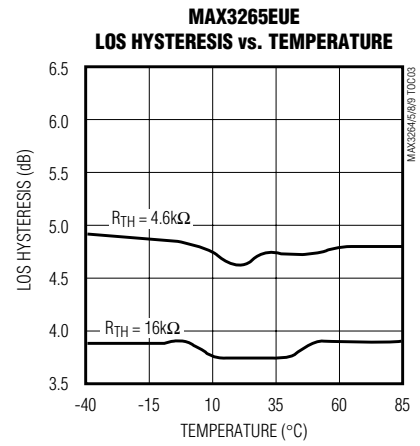
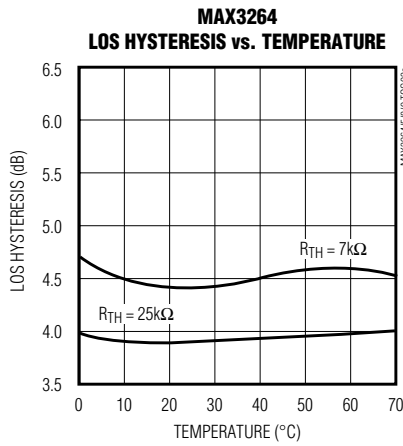
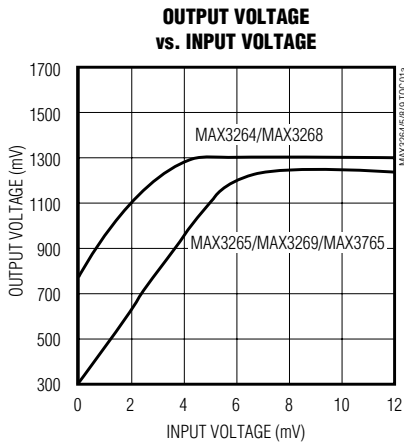

+3.0V to +5.5V, 1.25Gbps/2.5Gbps Limiting Amplifiers

Pin Description

PIN		NAME	FUNCTION
μMAX	TSSOP		
1, 4	3, 6	GND	Supply Ground
2	4	IN+	Noninverted Input Signal
3	5	IN-	Inverted Input Signal
5	8	TH	Loss-of-Signal Threshold. A resistor connected from this pin to ground sets the input signal level at which the loss-of-signal (LOS) output(s) is asserted. Refer to <i>Typical Operating Characteristics</i> and <i>Design Procedure</i> .
6	9	$\overline{\text{LOS}}$	Inverted Loss-of-Signal Output. $\overline{\text{LOS}}$ is high when the level of the input signal is above the preset threshold set by the TH input. $\overline{\text{LOS}}$ is asserted low when the signal level drops below the threshold.
7, 10	11, 14	V _{CC}	Supply Voltage
8	12	OUT-	Inverted Data Output
9	13	OUT+	Noninverted Data Output
—	1	CAZ1	Offset-Correction-Loop Capacitor. A capacitor connected between this pin and CAZ2 extends the time constant of the offset correction loop.
—	2	CAZ2	Offset-Correction-Loop Capacitor. A capacitor connected between this pin and CAZ1 extends the time constant of the offset correction loop. Refer to <i>Design Procedure</i> .
—	7	LEVEL	Output Current Level. When this pin is not connected, the CML output current is approximately 16mA. When this pin is connected to ground, the output current increases to approximately 20mA. (In the MAX3265CUB/MAX3765CUB, LEVEL is internally connected to ground.)
—	10	LOS	Noninverted Loss-of-Signal Output. LOS is low when the level of the input signal is above the preset threshold set by the TH input. LOS asserts high when the signal level drops below the threshold.
—	15	SQUELCH	Squelch Input. The squelch function is disabled when SQUELCH is not connected or is set to a TTL low level. When SQUELCH is set to a TTL high level and LOS is asserted, the data outputs, OUT+, and OUT-, are forced to static levels. See sections <i>PECL Output Buffer</i> and <i>CML Output Buffer</i> for more information. (In the MAX3265/MAX3268/MAX3269 10-pin μMAX, SQUELCH is not connected. In the MAX3765/MAX3768, SQUELCH is internally connected to V _{CC} .)
—	16	N.C.	No Connection
EP	EP	Exposed Paddle	Ground. The exposed paddle must be soldered to the circuit-board ground for proper thermal performance.

MAX3264/MAX3265/MAX3268/MAX3269/MAX3765/MAX3768

+3.0V to +5.5V, 1.25Gbps/2.5Gbps Limiting Amplifiers

MAX3264/MAX3265/MAX3268/MAX3269/MAX3765/MAX3768

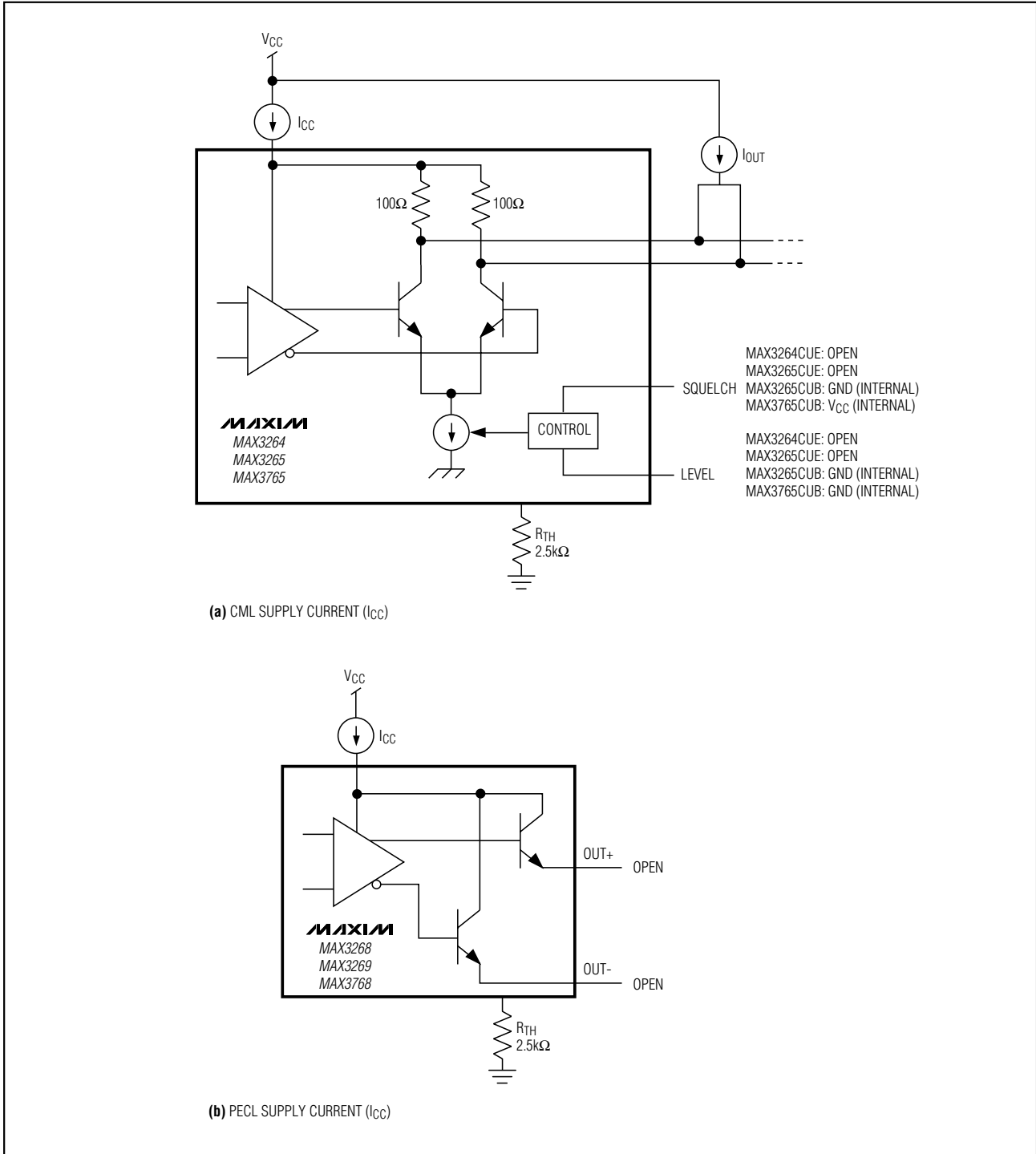

Figure 2. Power-Supply Current Measurement

+3.0V to +5.5V, 1.25Gbps/2.5Gbps Limiting Amplifiers

Input Buffer

The input buffer is designed to accept input signals from the MAX3266/MAX3267 transimpedance amplifiers. The input buffer provides a 100Ω input impedance between IN+ and IN-. Input VSWR is typically less than 2.0 for frequencies less than 2GHz. DC-coupling the inputs is not recommended; this prevents the DC offset-correction circuitry from functioning properly.

Gain Stage and Offset Correction

The limiting amplifier provides approximately 55dB (MAX3264/MAX3268/MAX3768) or 49dB (MAX3265/MAX3269/MAX3765) of gain. This large gain makes the amplifier susceptible to small DC offsets in the input signal. DC offsets as low as 1mV reduce the accuracy of the power-detection circuit and may cause deterministic jitter. A low-frequency feedback loop is integrated into the limiting amplifier to reduce input offset, typically to less than 100μV.

An external capacitor connected between CAZ1 and CAZ2, in parallel with internal capacitance, determines the time constant of the offset-correction circuit. The offset-correction circuit requires an average data-input mark density of 50% to prevent an increase in duty-cycle distortion and to ensure low deterministic jitter.

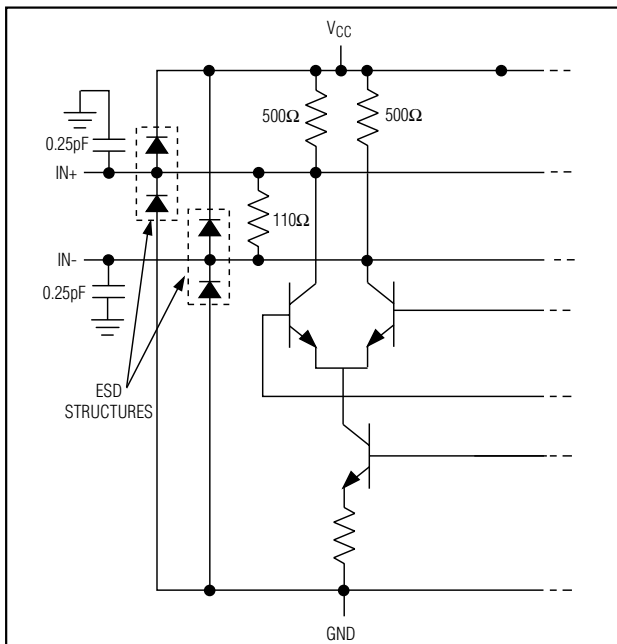

Figure 4. Input Circuit

CML Output Buffer

The MAX3264/MAX3265/MAX3765 CML output circuits (Figure 7) provide high tolerance to impedance mismatches and inductive connectors. The output current can be set to two levels. When the LEVEL pin is left unconnected, output current is approximately 16mA. Connecting LEVEL to ground sets the output current to approximately 20mA.

The squelch function is enabled when the SQUELCH pin is set to a TTL-high level or connected to VCC. The squelch function holds OUT+ and OUT- at a static voltage whenever the input signal power drops below the loss-of-signal threshold. In the 10-pin μMAX package of the MAX3265/MAX3268/MAX3269, the SQUELCH function is left internally unconnected. In the MAX3765/MAX3768, the SQUELCH function is always enabled by internally connecting it to VCC. SQUELCH operation for the MAX3264/MAX3265 is described in Table 1.

Table 1. Squelch Operation

LEVEL PIN	VOLTAGE WHEN SQUELCHED	
	OUT-	OUT+
Open	V _{CC} - 100mV	V _{CC}
GND	V _{CC} - 100mV	V _{CC} - 100mV

Internal Input/Output Schematics

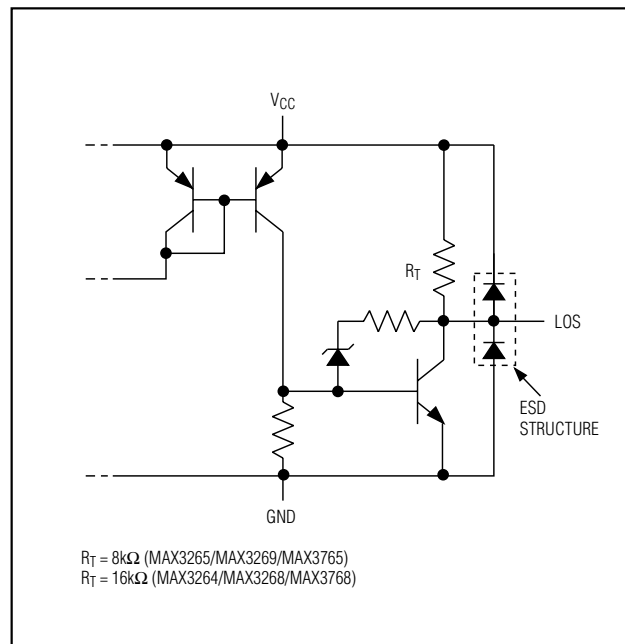

Figure 5. LOS Output Circuit

MAX3264/MAX3265/MAX3268/MAX3269/MAX3765/MAX3768

+3.0V to +5.5V, 1.25Gbps/2.5Gbps Limiting Amplifiers

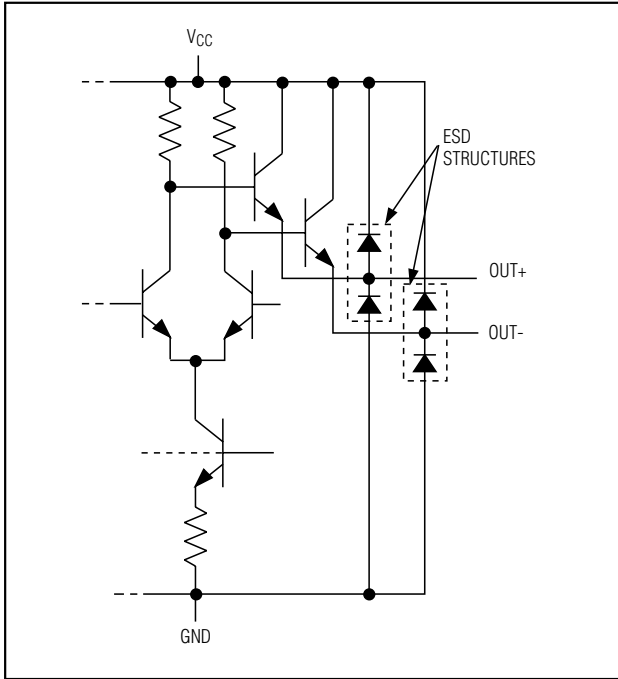

Figure 6. PECL Output Circuit

The buffer's output impedance is determined by the parallel combination of internal and external pullup resistors, which are chosen to match the impedance of the transmission line (Figure 1). The output buffer can be AC- or DC-coupled to the load.

PECL Output Buffer

The MAX3268/MAX3269/MAX3768 offer an industry-standard PECL output. The PECL outputs should be terminated to $V_{CC} - 2V$. Figure 6 shows the PECL output circuit. The squelch function forces $OUT+$ to a high level and $OUT-$ to a low level when the input is below the programmed LOS threshold. In the 10-pin μ MAX, SQUELCH is left unconnected.

Design Procedure

Program the LOS Assert Threshold

The loss-of-signal threshold is programmed by external resistor R_{TH} . See the LOS Threshold vs. R_{TH} graph in the *Typical Operating Characteristics*.

Select the Coupling Capacitors

The coupling capacitors (C_{IN} , C_{OUT}) should be selected to minimize the receiver's deterministic jitter. Jitter is

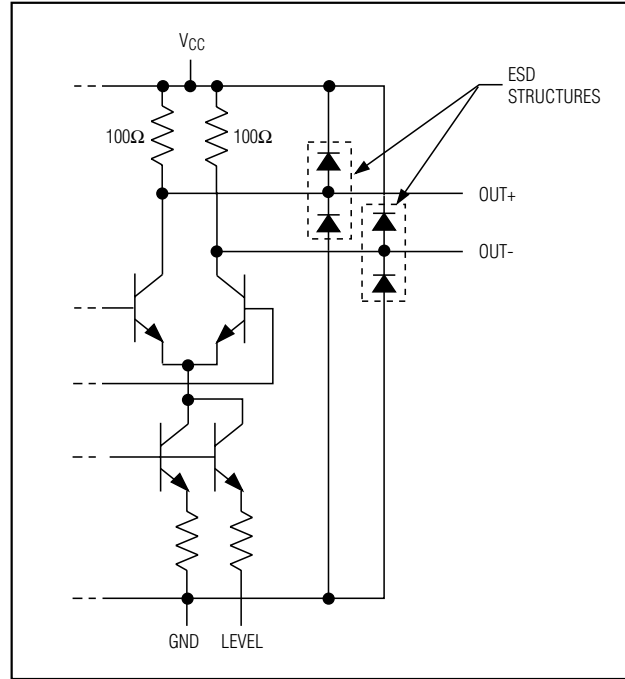

Figure 7. CML Output Circuit

minimized when the input low-frequency cutoff (f_{IN}) is placed at a low frequency:

$$f_{IN} = 1 / [2\pi(50)(C)]$$

For Fibre Channel, Gigabit Ethernet, or other applications using 8B/10B data coding, select (C_{IN} , C_{OUT}) $\geq 0.01\mu F$, which provides $f_{IN} < 320kHz$. For ATM/SONET or other applications using scrambled NRZ data, select (C_{IN} , C_{OUT}) $\geq 0.1\mu F$, which provides $f_{IN} < 32kHz$.

Select the Offset-Correction Capacitor (MAX3264/MAX3265 TSSOP Only)

To maintain stability, it is important to keep a one-decade separation between f_{IN} and the low-frequency cutoff (f_{OC}) associated with the DC-offset-correction circuit.

$$\begin{aligned} f_{OC} &= 75 / [2\pi 60k (CAZ + 100pF)] \\ &= 200 \times 10^{-6} / (CAZ + 100pF) \end{aligned}$$

For Fibre Channel, Gigabit Ethernet, or other applications using 8B/10B data coding, leave pins CAZ1, and CAZ2 open ($f_{OC} = 2MHz$). For ATM/SONET or other applications using scrambled NRZ data, select CAZ $\geq 0.1\mu F$, which typically provides $f_{OC} = 2kHz$.

+3.0V to +5.5V, 1.25Gbps/2.5Gbps Limiting Amplifiers

Applications Information

Optical Hysteresis

In an optical receiver, the electrical power change at the limiting amplifier is 2x the optical power change.

As an example, if a receiver's optical input power (x) increases by a factor of two, and the preamplifier is linear, then the voltage input to the limiting amplifier also increases by a factor of two.

The optical power change is $10\log(2x/x) = 10\log(2) = +3\text{dB}$.

At the limiting amplifier, the electrical power change is:

$$10\log \frac{(2V_{IN})^2 / R_{IN}}{V_{IN}^2 / R_{IN}} = 10\log(2^2) = 20\log(2) = +6\text{dB}$$

The MAX3264/MAX3265/MAX3268/MAX3269/MAX3765s' typical voltage hysteresis is 4.4dB. This provides an optical hysteresis of 2.2dB.

GBIC Loss of Signal

In a GBIC application, the GBIC's LOS output must be high impedance when $V_{CC_MODULE} = \text{GND}$. Figure 8 shows the recommended circuit to maintain high impedance. ESD protection diodes on the MAX3264/MAX3265/MAX3268/MAX3269/MAX3765/MAX3768 LOS outputs can be turned on when $V_{CC_HOST} > V_{CC_MODULE}$.

PECL Terminations

The standard PECL termination (50Ω to $V_{CC} - 2\text{V}$) is recommended for best performance and output characteristics (see Figure 1). The data outputs operate at high speed and should always drive transmission lines with matched, balanced terminations.

Figure 9 shows an alternate method for terminating the data outputs. The technique provides approximately 8mA DC bias current, with a 45Ω AC load, for the output termination. This technique is useful for viewing the output on an oscilloscope or changing the PECL reference voltage.

Wire Bonding Dice

For high current density and reliable operation, the MAX3264/MAX3265/MAX3268/MAX3269 use gold metallization. Make connections to the dice with gold wire only, and use ballbonding techniques (wedge bonding is not recommended). Die-pad size is 4 mils square, with a 6-mil pitch. Die thickness is 15 mils (0.375mm).

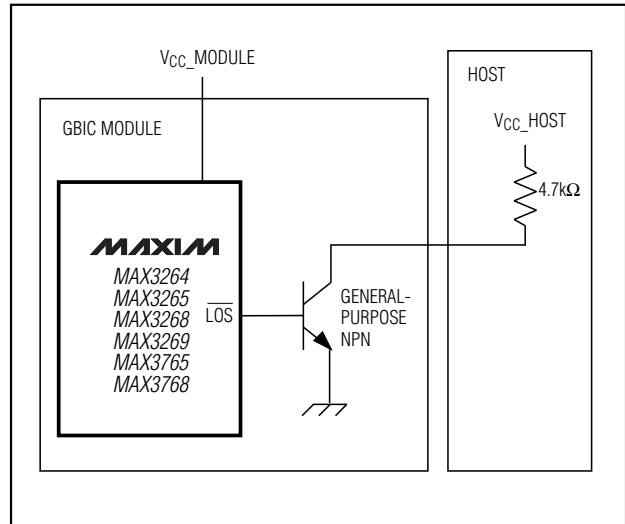

Figure 8. Recommended GBIC LOS Circuit

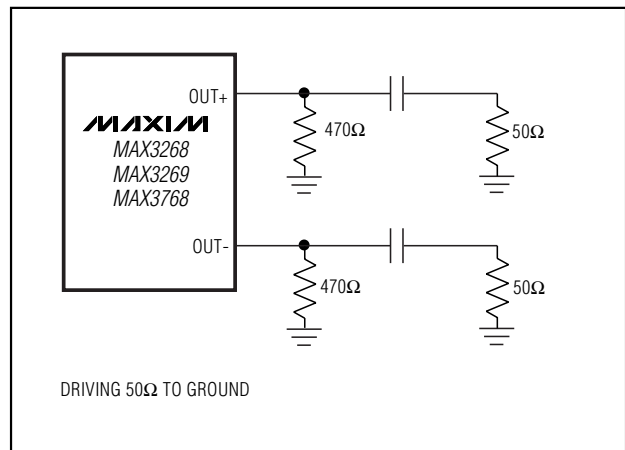
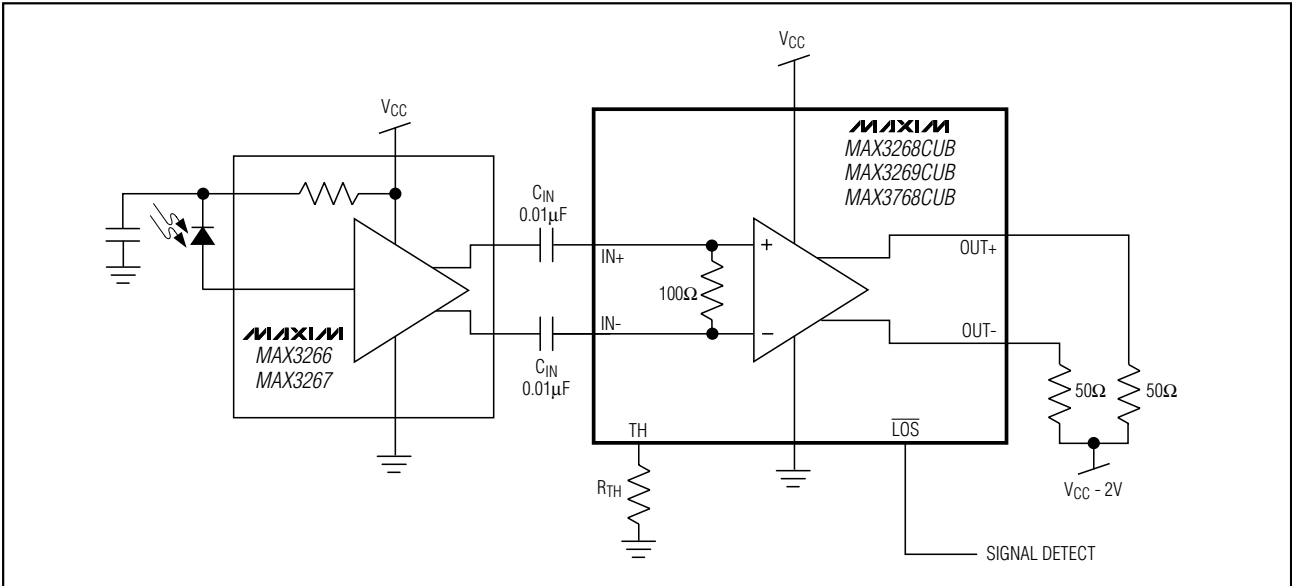

Figure 9. Alternative PECL Termination

MAX3264/MAX3265/MAX3268/MAX3269/MAX3765/MAX3768

+3.0V to +5.5V, 1.25Gbps/2.5Gbps Limiting Amplifiers

Typical Operating Circuits (continued)



Pin Configurations

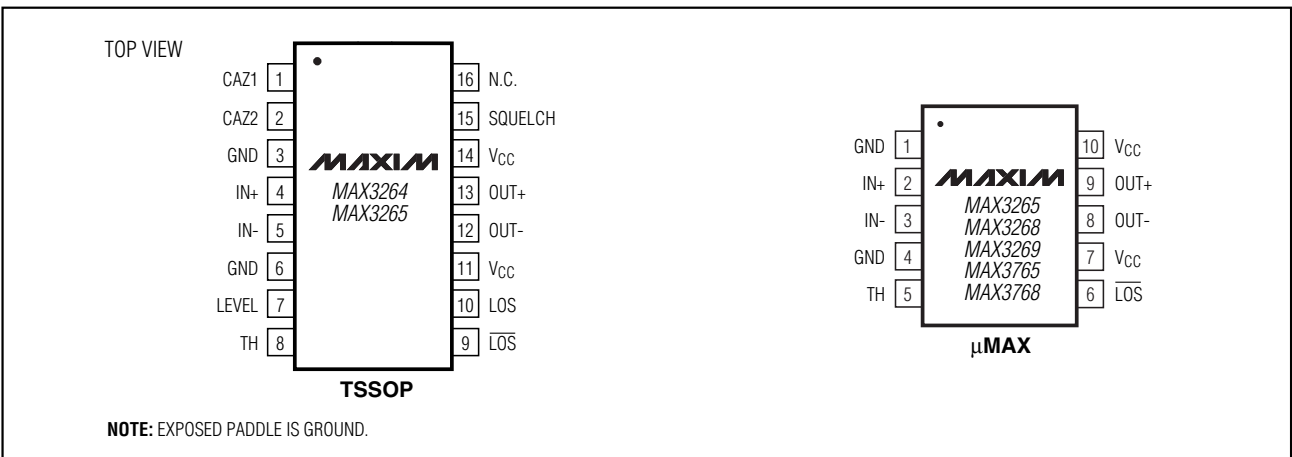

+3.0V to +5.5V, 1.25Gbps/2.5Gbps Limiting Amplifiers

Selector Guide

PART	OUTPUT	DATA RATE (Gbps)	PIN-PACKAGE	SQUELCH FUNCTION	CML OUTPUT LEVEL
MAX3264	CML	1.25	16 TSSOP-EP	Selectable	Selectable
MAX3265	CML	2.5	16 TSSOP-EP	Selectable	Selectable
			10 μ MAX-EP	Disabled	Maximum*
MAX3268	PECL	1.25	10 μ MAX-EP	Disabled	N/A
MAX3269	PECL	2.5	10 μ MAX-EP	Disabled	N/A
MAX3765	CML	2.5	10 μ MAX-EP	Enabled	Maximum*
MAX3768	PECL	1.25	10 μ MAX-EP	Enabled	N/A

*LEVEL pin grounded

Chip Topographies

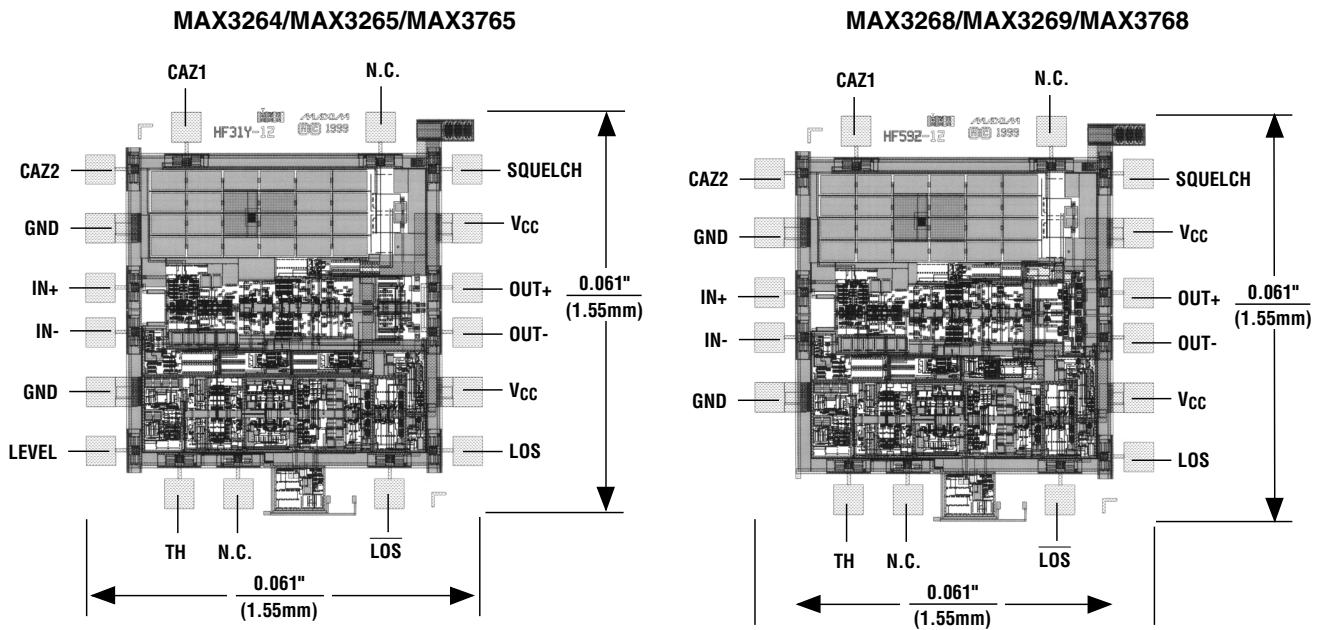

MAX3264/MAX3265/MAX3765
TRANSISTOR COUNT: 726
MAX3268/MAX3269/MAX3768
TRANSISTOR COUNT: 728
SUBSTRATE CONNECTED TO GND

+3.0V to +5.5V, 1.25Gbps/2.5Gbps Limiting Amplifiers

Package Information

(The package drawing(s) in this data sheet may not reflect the most current specifications. For the latest package outline information, go to www.maxim-ic.com/packages.)

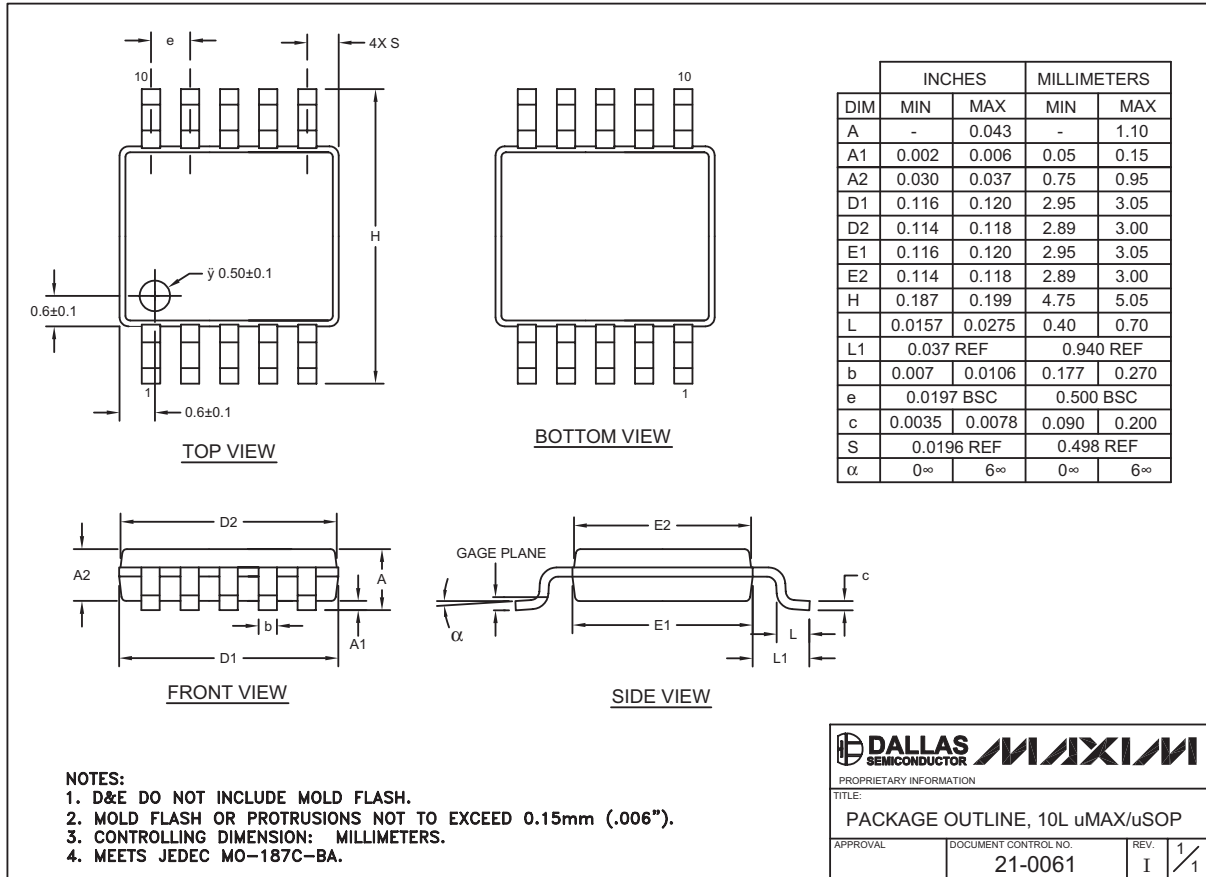

10LMAX.EPS

3.0V to 5.5V, 1.25Gbps/2.5Gbps Limiting Amplifiers

Package Information (continued)

(The package drawing(s) in this data sheet may not reflect the most current specifications. For the latest package outline information, go to www.maxim-ic.com/packages.)

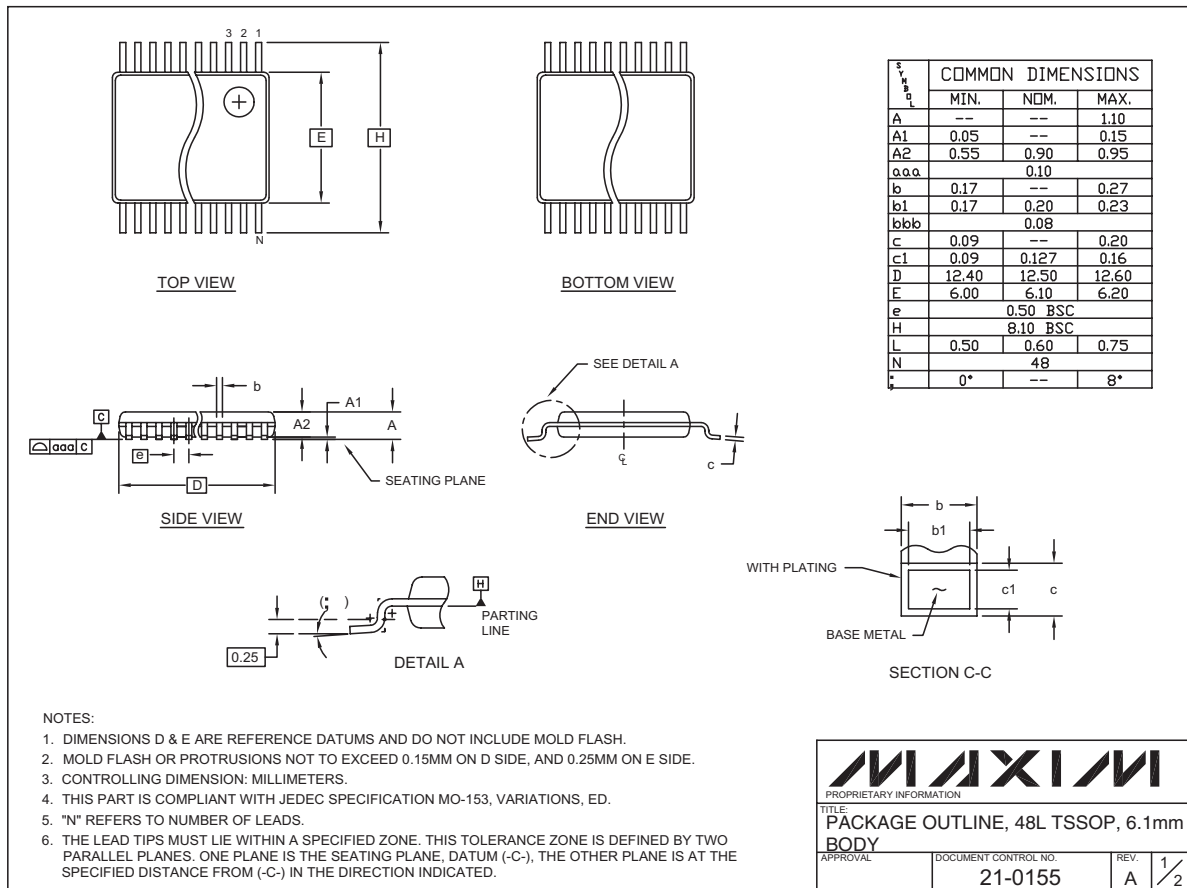

48L TSSOP-EFS

MAX3264/MAX3265/MAX3268/MAX3269/MAX3765

Maxim cannot assume responsibility for use of any circuitry other than circuitry entirely embodied in a Maxim product. No circuit patent licenses are implied. Maxim reserves the right to change the circuitry and specifications without notice at any time.

17 Maxim Integrated Products, 120 San Gabriel Drive, Sunnyvale, CA 94086 408-737-7600

© 2003 Maxim Integrated Products

Printed USA

MAXIM is a registered trademark of Maxim Integrated Products.