



+5V Multiprotocol, Software-Selectable Clock Transceiver

MAX13172E

General Description

The MAX13172E is a four-driver/four-receiver multiprotocol transceiver that operates from a single +5V supply in conjunction with the MAX13170E and MAX13174E. The MAX13172E, along with the MAX13170E and the MAX13174E, form a complete software-selectable data terminal equipment (DTE) or data communication equipment (DCE) interface port that supports the V.28 (RS-232), V.10/V.11 (RS-449/V.36, EIA-530, EIA-530A, X.21, RS-423), and V.35 protocols. The MAX13172E transceiver carries serial-interface control signaling, while the MAX13170E carries the high-speed clock and data signals. Typically, the MAX13170E is terminated using the MAX13174E.

The MAX13172E is available in a 5.3mm x 10.2mm, 28-pin SSOP package and operates over the 0°C to +70°C commercial temperature range.

Applications

- Data Networking
- CSU/DSU Devices
- Data Routers
- Switches
- PCI Cards
- Telecommunication Equipment

Features

- ◆ The MAX13170E/MAX13172E/MAX13174E Chipset is a Pin-for-Pin Upgrade to the MXL1544/MAX3175/ MXL1543/MXL1543B Chipset
- ◆ Chipset Operates from a Single +5V Supply
- ◆ Software-Selectable DCE/DTE Configurations
- ◆ Supports V.28 (RS-232), V.10/V.11 (RS-449/V.36, EIA-530, EIA-530A, X.21, RS-423) Protocols
- ◆ Flowthrough Pin Configuration
- ◆ Fail-Safe Receivers While Maintaining V.11 and V.35 Compatibility
- ◆ Extremely Low Maximum Shutdown Current (No-Cable Mode)
- ◆ TUV-Certified NET1/NET2 and TBR1/TBR2 Compliant (Pending)
- ◆ Extended ESD Protection for All Transmitter Outputs and Receivers Inputs to GND
 - ±10kV Using the Human Body Model
 - ±3kV Using the Contact Method Specified in IEC 61000-4-2
 - ±3kV Using the Air Gap Discharge Method Specified in IEC 61000-4-2

Ordering Information

PART	TEMP RANGE	PIN-PACKAGE
MAX13172ECAI+	0°C to +70°C	28 SSOP

Pin Configuration appears at end of data sheet.

+Denotes a lead-free package.

Typical Operating Circuit

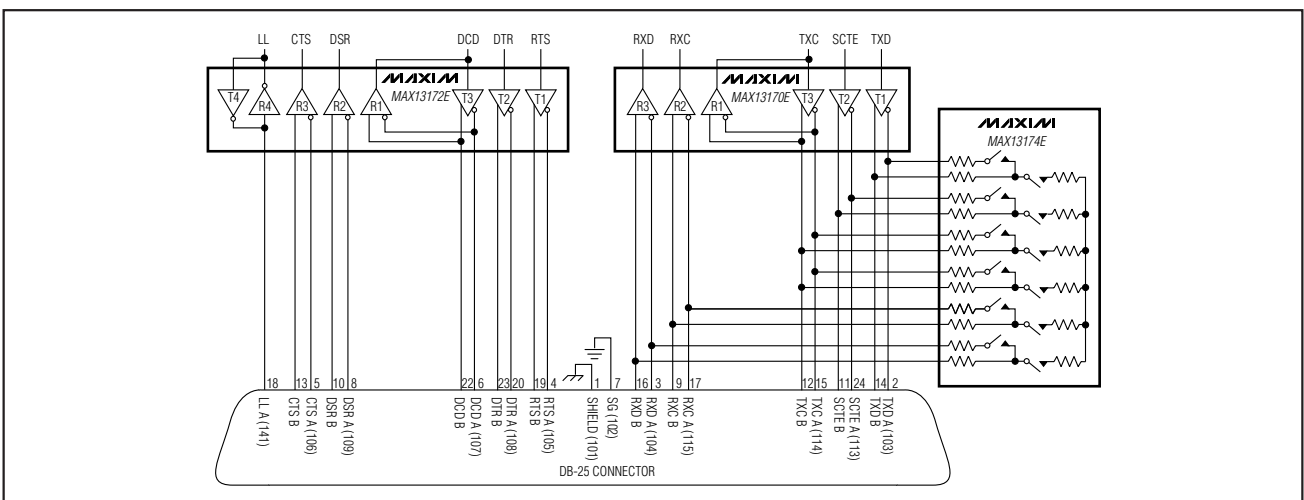

+5V Multiprotocol, Software-Selectable Clock Transceiver

ABSOLUTE MAXIMUM RATINGS

(All voltages referenced to GND, unless otherwise noted.)

Supply Voltages

V _{CC}	-0.3V to +6V
V _{DD}	-0.3V to +7.1V
V _{EE}	+0.3V to -7.1V
V _{DD} to V _{CC}	+0.3 to +6V

Logic Input Voltages

M0, M1, M2, DCE/DTE, T _{IN} , INVERT.....	-0.3V to +6V
--	--------------

Logic Output Voltages

R _{OUT}	-0.3V to (V _{CC} + 0.3V)
------------------------	-----------------------------------

Transmitter Outputs

T _{OUT} , T _{OUT} /R _{IN} (No-Cable Mode, V ₂₈ only).....	-15V to +15V
Short-Circuit Duration to GND.....	Continuous

Receiver Inputs

R _{IN} , T _{OUT} /R _{IN}	-15V to +15V
R _{INA} to R _{INB} , T3OUTA/R1INA to T3OUT/R1INB.....	-15V to +15V
Continuous Power Dissipation (T _A = +70°C)	
28-Pin SSOP (derate 9.5mW/°C above +70°C).....	762mW
Junction-to-Case Thermal Resistance (θ _{JC}) (Note 1)	
28-Pin SSOP.....	25°C/W
Junction-to-Ambient Thermal Resistance (θ _{JA}) (Note 1)	
28-Pin SSOP.....	67°C/W
Operating Temperature Range.....	0°C to 70°C
Junction Temperature.....	+150°C
Storage Temperature Range.....	-65°C to +150°C
Lead Temperature (soldering, 10s).....	+300°C

Note 1: Package thermal resistances were obtained using the method described in JESD51-7, using a four-layer board. For detailed information on package thermal considerations, refer to www.maxim-ic.com/thermal-tutorial.

Stresses beyond those listed under "Absolute Maximum Ratings" may cause permanent damage to the device. These are stress ratings only, and functional operation of the device at these or any other conditions beyond those indicated in the operational sections of the specifications is not implied. Exposure to absolute maximum rating conditions for extended periods may affect device reliability.

ELECTRICAL CHARACTERISTICS

(V_{CC} = 4.5V to 5.5V, T_A = T_{MIN} to T_{MAX}. Typical values are at V_{CC} = 5V, and T_A = +25°C, V₂₈ mode only: V_{DD} = +5.6V to +7.1V and V_{EE} = -7.1V to -5.4V. Typical values are at V_{DD} = +6.9V and V_{EE} = -6.7V, no-cable mode: V_{DD} = V_{CC} and V_{EE} = 0, other modes: V_{DD} = +5.15V to +5.7V and V_{EE} = -4.84V to -4.16V. Typical value are at V_{DD} = +5.3V and V_{EE} = -4.5V.) (Notes 2, 3)

PARAMETER	SYMBOL	CONDITIONS	MIN	TYP	MAX	UNITS
V _{CC} Operating Range	V _{CC}		4.5		5.5	V
V _{DD} Operating Range	V _{DD}	V ₂₈ mode	5.6		7.1	V
		V ₁₀ or V ₁₁ mode	5.15		5.7	
V _{EE} Operating Range	V _{EE}	V ₂₈ mode	-7.1		-5.4	V
		V ₁₀ or V ₁₁ mode	-4.84		-4.16	
V _{CC} Supply Current (DCE Mode) (Digital Inputs = GND or V _{CC}) (Transmitter Outputs Static)	I _{CC}	CH1, CH3 = V ₁₁ , CH2 = V ₁₀ , CH4 = V ₁₀ , no load		5.5		mA
		CH1, CH3 = V ₁₁ , CH2 = V ₁₀ , CH4 = V ₁₀ , full load		95	135	
		CH1, CH2, CH3 = V ₁₁ , CH4 = V ₁₀ , full load		138	180	
		V ₂₈ mode		3.5	9	
		No cable mode; M0, M1, M2, DCE/DTE, INVERT, open or at V _{CC} (V _{DD} = V _{CC} and V _{EE} = GND)		0	10	μA
Internal Power Dissipation (DCE Mode)	P _D	CH1, CH3 = V ₁₁ , CH2, CH4 = V ₁₀ , no load		300		mW
		V ₂₈ mode, full load		54		

+5V Multiprotocol, Software-Selectable Clock Transceiver

MAX13172E

ELECTRICAL CHARACTERISTICS (continued)

($V_{CC} = 4.5V$ to $5.5V$, $T_A = T_{MIN}$ to T_{MAX} . Typical values are at $V_{CC} = 5V$, and $T_A = +25^\circ C$, V.28 mode only: $V_{DD} = +5.6V$ to $+7.1V$ and $V_{EE} = -7.1V$ to $-5.4V$. Typical values are at $V_{DD} = +6.9V$ and $V_{EE} = -6.7V$, no-cable mode: $V_{DD} = V_{CC}$ and $V_{EE} = 0$, other modes: $V_{DD} = +5.15V$ to $+5.7V$ and $V_{EE} = -4.84V$ to $-4.16V$. Typical value are at $V_{DD} = +5.3V$ and $V_{EE} = -4.5V$.) (Notes 2, 3)

PARAMETER	SYMBOL	CONDITIONS	MIN	TYP	MAX	UNITS
V _{EE} Supply Current	I _{EE}	CH1, CH3 = V.11, CH2 = V.10 or V.11, CH4 = V.10, no load		2.1		mA
		CH1, CH2, CH3 = V.11, CH4 = V.10, full load (output low)		13	30	
		CH1, CH3 = V.11, CH2, CH4 = V.10, full load (output low)		22	30	
		V.28 mode, no load		1		
		V.28 mode, full load (output low)		12	18	
		No cable mode (V _{DD} = V _{CC} and V _{EE} = GND)		0	10	μA
V _{DD} Supply Current	I _{DD}	CH1, CH3 = V.11, CH2 = V.10 or V.11, CH4 = V.10, no load		0.6		mA
		CH1, CH2, CH3 = V.11, CH4 = V.10, full load (output high)		11	30	
		CH1, CH3 = V.11, CH2, CH4 = V.10, full load (output high)		22	30	
		V.28 mode, no load		2.5		
		V.28 mode, full load (output high)		12	10	
		No cable mode (V _{DD} = V _{CC} and V _{EE} = GND)		0	10	μA
Thermal-Shutdown Protection	THSD			+145		°C
LOGIC INPUTS (M0, M1, M2, DCE/DTE, INVERT, T1IN, T2IN, T3IN, T4IN)						
Input High Voltage	V _{IH}		0.66 x V _{CC}			V
Input Low Voltage	V _{IL}		0.33 x V _{CC}			V
Logic-Input Current	I _{IIN}	T1IN, T2IN, T3IN, T4IN	-1		+1	μA
Pullup Resistor	R _{PUIN}	M0, M1, M2, DCE/DTE, INVERT to V _{CC}	50	100	166	kΩ
LOGIC OUTPUTS (R1OUT, R2OUT, R3OUT, R4OUT)						
Output High Voltage	V _{OH}	I _{SOURCE} = 4mA	0.66 x V _{CC}			V
Output Low Voltage	V _{OL}	I _{SINK} = 4mA	0.33 x V _{CC}			V
Output Pullup Resistor	R _{PUY}	No cable mode (to V _{CC})	71.4			kΩ
Transmitter Output Leakage Current	I _Z	-0.25V < V _{OUT} < +0.25V, V _{CC} = 0 or no cable mode		±1	±5	μA
V.11 TRANSMITTER						
Open-Circuit Differential Output Voltage	V _{ODO}	Open circuit, R = 1.95kΩ, Figure 1	-V _{CC}		+V _{CC}	V
Loaded Differential Output Voltage (Note 4)	I _{VODLI}	R = 50Ω, Figure 1	0.5 x V _{ODO}			V
		R = 50Ω, Figure 1	2			
Change in Magnitude of Output Differential Voltage	ΔV _{OD}	R = 50Ω, Figure 1			0.2	V

+5V Multiprotocol, Software-Selectable Clock Transceiver

ELECTRICAL CHARACTERISTICS (continued)

($V_{CC} = 4.5V$ to $5.5V$, $T_A = T_{MIN}$ to T_{MAX} . Typical values are at $V_{CC} = 5V$, and $T_A = +25^\circ C$, V.28 mode only: $V_{DD} = +5.6V$ to $+7.1V$ and $V_{EE} = -7.1V$ to $-5.4V$. Typical values are at $V_{DD} = +6.9V$ and $V_{EE} = -6.7V$, no-cable mode: $V_{DD} = V_{CC}$ and $V_{EE} = 0$, other modes: $V_{DD} = +5.15V$ to $+5.7V$ and $V_{EE} = -4.84V$ to $-4.16V$. Typical value are at $V_{DD} = +5.3V$ and $V_{EE} = -4.5V$.) (Notes 2, 3)

PARAMETER	SYMBOL	CONDITIONS	MIN	TYP	MAX	UNITS
Common-Mode Output Voltage	V_{OC}	$R = 50\Omega$, Figure 1			3.0	V
Change in Magnitude of Common-Mode Output Voltage	ΔV_{OC}	$R = 50\Omega$, Figure 1			0.2	V
Short-Circuit Current	I_{SC}	$V_{OUT} = GND$			150	mA
Rise Time	t_R	Figures 2, 5		4	10	ns
Fall Time	t_F	Figures 2, 5		6	10	ns
Transmitter Input-to-Output Prop Delay	t_{PHL}, t_{PLH}	Figures 2, 5			22	ns
Data Skew	$ t_{PHL} - t_{PLH} $	Figures 2, 5 (Note 5)			3	ns
Output-to-Output Skew	t_{SKEWT}	Figures 2, 5 (Notes 5, 6)			3	ns
V.11 RECEIVER						
Differential Threshold Voltage	V_{TH}	$-7V \leq V_{CM} \leq +7V$	-200		-50	mV
Input Hysteresis	ΔV_{TH}	$-7V \leq V_{CM} \leq +7V$		15		mV
Receiver Input Current	I_{IN}	$-10V \leq V_{A,B} \leq +10V$	-0.66		+0.66	mA
Receiver Input Resistance	R_{IN}	$-10V \leq V_{A,B} \leq +10V$	15	30		k Ω
Rise or Fall Time	t_R, t_F	Figures 2, 6		3		ns
Receiver Input-to-Output Delay	t_{PHL}, t_{PLH}	Figures 2, 6		16	26	ns
Data Skew	$ t_{PHL} - t_{PLH} $	Figures 2, 6 (Note 5)			3.5	ns
Output-to-Output Skew	t_{SKEWR}	(Notes 5, 6)			3.5	ns
V.10 TRANSMITTER						
Open-Circuit Output Voltage Swing (Figure 3)	V_O	$R_L = 3.9k\Omega$ (out high)	4		6	V
		$R_L = 3.9k\Omega$ (out low)	-6		-4	
Output Voltage Swing (Figure 3)	V_T	$R_L = 450\Omega$ (out high)	3.6			V
		$R_L = 450\Omega$ (out low)			-3.6	
		$R_L = 450\Omega$	$0.9 \times V_O $			
Short-Circuit Current	I_{SC}	$V_O = GND$	-55		+55	mA
Rise or Fall Time	t_R, t_F	$R_L = 450\Omega, C_L = 100pF$ (Figure 7)		2		μs
Transmitter Input-to-Output Delay	t_{PLH}, t_{PHL}	$R_L = 450\Omega, C_L = 100pF$ (Figure 7)		1		μs
V.10 RECEIVER						
Input Threshold Voltage	V_{TH}	Measured on inverting input (A)	50		250	mV
Input Hysteresis	ΔV_{TH}			25		mV
Receiver Input Current	I_{IN}	$-10V \leq V_A \leq +10V$	-0.66		+0.66	mA
Receiver Input Impedance	R_{IN}	$-10V \leq V_A \leq +10V$	15	30		k Ω
Rise or Fall Time	t_R, t_F	Figures 4, 8		3		ns
Receiver Input-to-Output Delay from Low to High	t_{PLH}	Figures 4, 8		55		ns
Receiver Input-to-Output Delay from High to Low	t_{PHL}	Figures 4, 8		109		ns
Data Skew	$ t_{PHL} - t_{PLH} $	Figures 4, 8		60		ns

+5V Multiprotocol, Software-Selectable Clock Transceiver

MAX13172E

ELECTRICAL CHARACTERISTICS (continued)

($V_{CC} = 4.5V$ to $5.5V$, $T_A = T_{MIN}$ to T_{MAX} . Typical values are at $V_{CC} = 5V$, and $T_A = +25^\circ C$, V.28 mode only: $V_{DD} = +5.6V$ to $+7.1V$ and $V_{EE} = -7.1V$ to $-5.4V$. Typical values are at $V_{DD} = +6.9V$ and $V_{EE} = -6.7V$, no-cable mode: $V_{DD} = V_{CC}$ and $V_{EE} = 0$, other modes: $V_{DD} = +5.15V$ to $+5.7V$ and $V_{EE} = -4.84V$ to $-4.16V$. Typical value are at $V_{DD} = +5.3V$ and $V_{EE} = -4.5V$.) (Notes 2, 3)

PARAMETER	SYMBOL	CONDITIONS	MIN	TYP	MAX	UNITS	
V.28 TRANSMITTER							
Output-Voltage Swing	V_{OD}	Open circuit (output high)			V_{DD}	V	
		Open circuit (output low)			V_{EE}		
		$R_L = 3k\Omega$	Output high	+5	+6.8		
			Output low		-6.8		-5
Short-Circuit Current	I_{SC1}				85	mA	
Output Slew Rate	$SR_{R/F}$	$R_L = 3k\Omega$, $C_L = 2500pF$, Figures 3, 9	4		30	V/ μs	
Transmitter Input-to-Output Propagation Delay	t_{PHL} , t_{PLH}	$R_L = 3k\Omega$, $C_L = 2500pF$, Figures 3, 9	1		2	μs	
V.28 RECEIVER							
Input Threshold Low	V_{IL}		0.8			V	
Input Threshold High	V_{IH}				2	V	
Input Hysteresis	V_{HYST}		0.25			V	
Input Resistance	R_{IN}	$-15V \leq V_{IN} \leq +15V$	3	5	7	$k\Omega$	
Rise or Fall Time	t_R , t_F	Figures 4, 10	3			ns	
Receiver Input-to-Output Delay	t_{PHL} , t_{PLH}	Figures 4, 10			150	ns	
ESD PROTECTION (T_OUT_, T_OUT_/R_OUT_, R_IN_ to GND)							
ESD Protection		Contact Discharge IEC61000-4-2			± 3	kV	
		Air Gap Discharge IEC61000-4-2			± 3		
		Human Body Model			± 10		

Note 2: The MAX13172E is designed to operate with V_{DD} and V_{EE} supplied by the MAX13170E charge pump.

Note 3: All devices are 100% production tested at $T_A = +25^\circ C$, and are guaranteed by design for $T_A = 0^\circ C$ to $+70^\circ C$ as specified.

Note 4: $|V_{ODL}|$ is guaranteed at both $0.5 \times V_{OD0}$ and $2V$.

Note 5: Guaranteed by design, not production tested.

Note 6: Output-to-output skews are evaluated as a difference of propagation delays between different channels in the same condition and for the same polarity (LH or HL).

+5V Multiprotocol, Software-Selectable Clock Transceiver

Typical Operating Characteristics

(T_A = +25°C, unless otherwise noted.)

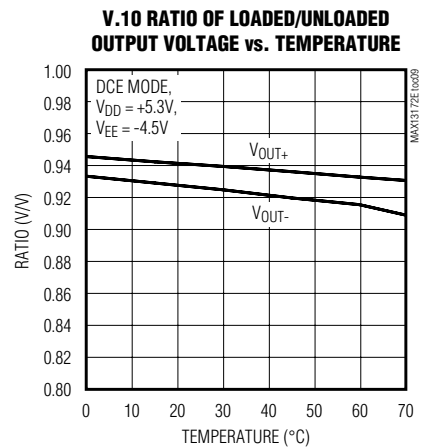
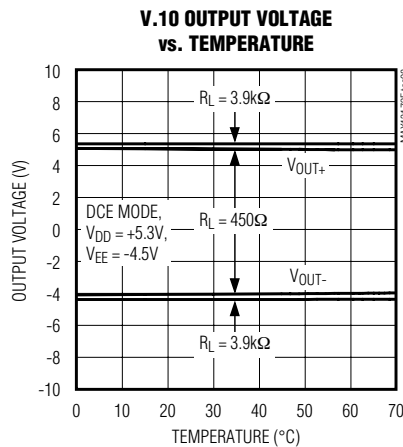
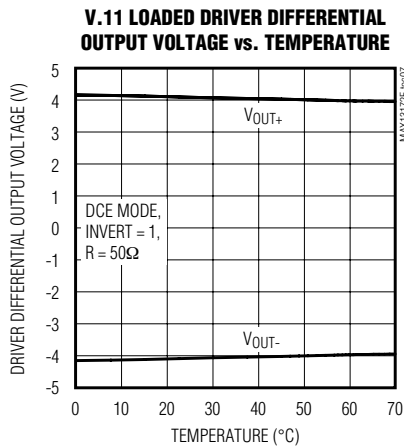
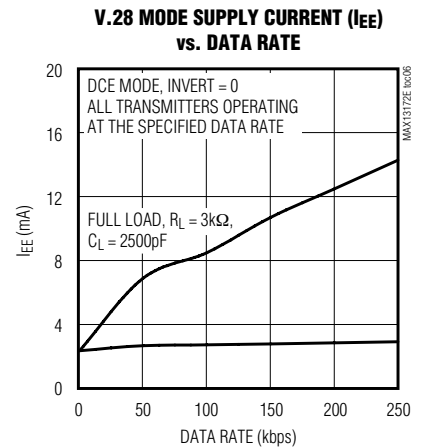
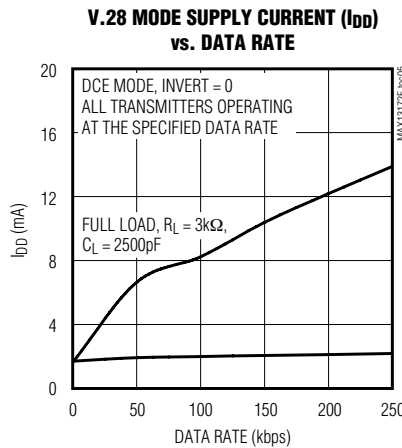
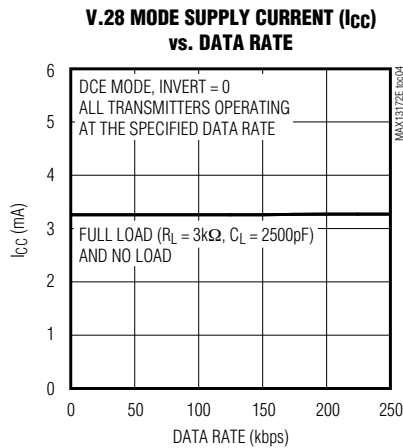
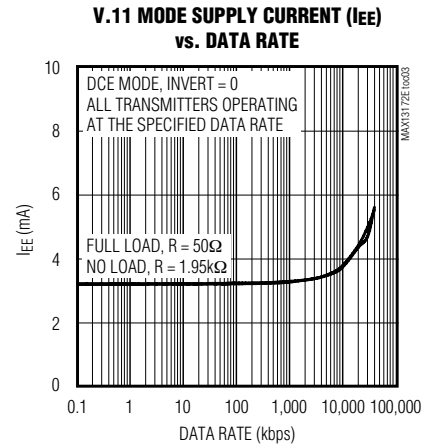
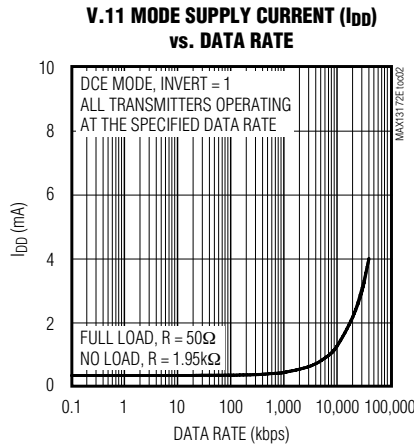
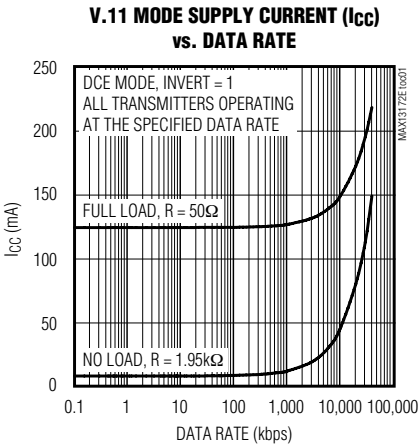

+5V Multiprotocol, Software-Selectable Clock Transceiver

MAX13172E

Typical Operating Characteristics (continued)

($T_A = +25^\circ\text{C}$, unless otherwise noted.)

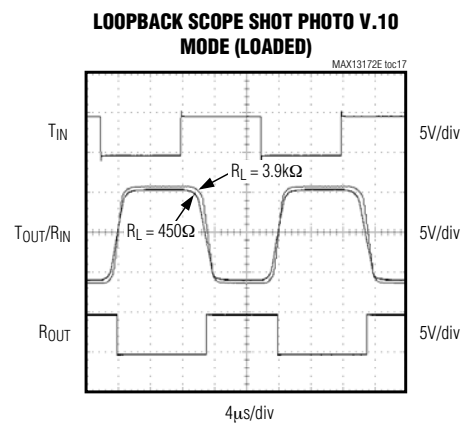
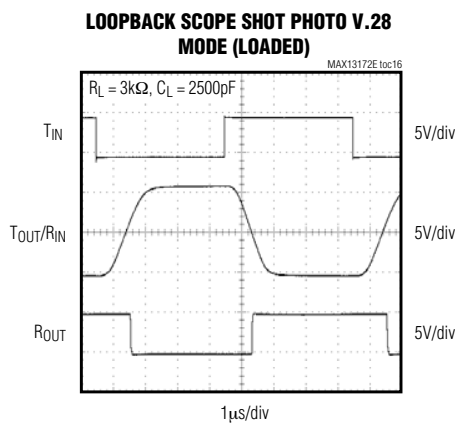
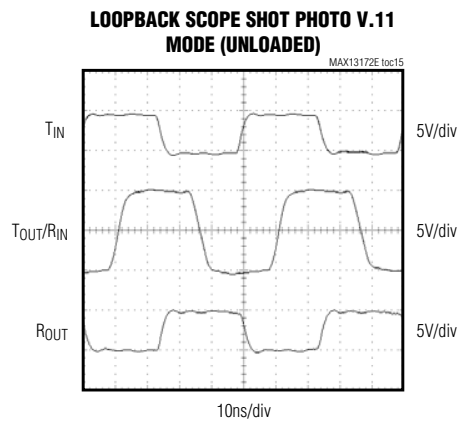
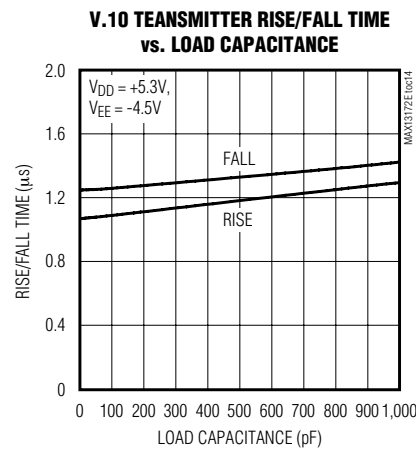
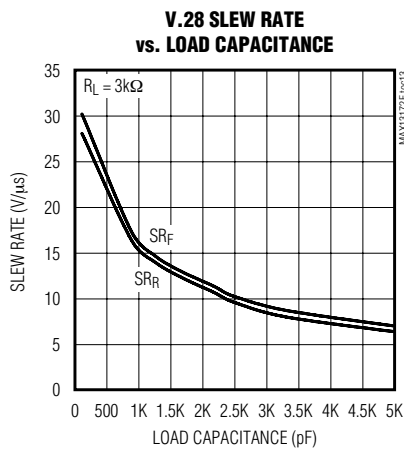
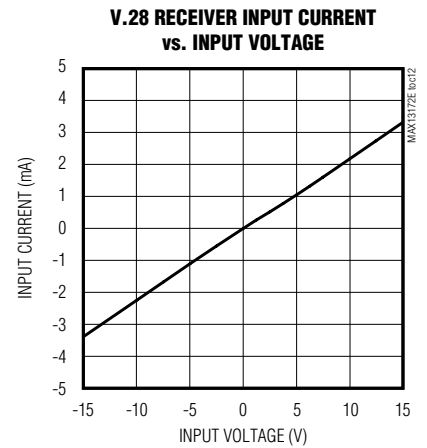
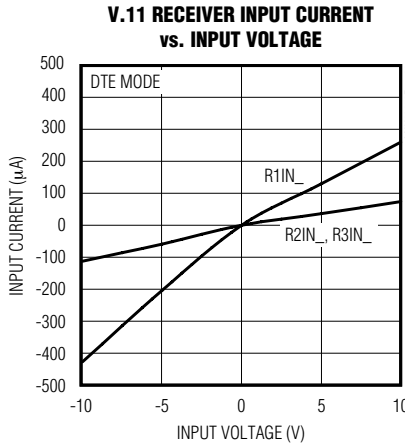
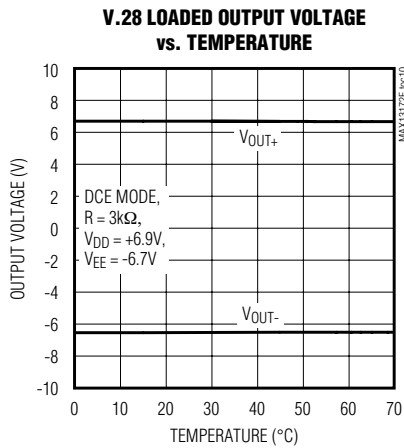

+5V Multiprotocol, Software-Selectable Clock Transceiver

Pin Description

PIN	NAME	FUNCTION
1	V _{CC}	Device Supply Voltage. Bypass V _{CC} with a 1μF capacitor-to-ground as close as possible to the device.
2	V _{DD}	Positive Supply Voltage Input. V _{DD} is generated by the MAX13170E. Bypass V _{DD} with a 1μF capacitor to ground.
3	T1IN	Transmitter 1 Logic Input
4	T2IN	Transmitter 2 Logic Input
5	T3IN	Transmitter 3 Logic Input
6	R1OUT	Receiver 1 Logic Output
7	R2OUT	Receiver 2 Logic Output
8	R3OUT	Receiver 3 Logic Output
9	T4IN	Transmitter 4 Logic Output
10	R4OUT	Receiver 4 Logic Output
11	M0	Mode Select 0 Input. Internally pullup to V _{CC} .
12	M1	Mode Select 1 Input. Internally pullup to V _{CC} .
13	M2	Mode Select 2 Input. Internally pullup to V _{CC} .
14	DCE/DTE	DCE/DTE Input. Internally pullup to V _{CC} . Logic level high selects DCE interface.
15	INVERT	T4/R4 Select Input. Internally pullup to V _{CC} . INVERT reverses the action of DCE/DTE for Channel 4.
16	T4OUTA/ R4INA	Transmitter 4 Output/Inverting Receiver Input
17	R3INB	Receiver 3 Noninverting Input
18	R3INA	Receiver 3 Inverting Input
19	R2INB	Receiver 2 Noninverting Input
20	R2INA	Receiver 2 Inverting Input
21	T3OUTB/ R1INB	Transmitter 3 Noninverting Output/Receiver 1 Noninverting Input
22	T3OUTA/ R1INA	Transmitter 3 Inverting Output/Receiver 1 Inverting Input
23	T2OUTB	Transmitter 2 Noninverting Output
24	T2OUTA	Transmitter 2 Inverting Output
25	T1OUTB	Transmitter 1 Noninverting Output
26	T1OUTA	Transmitter 1 Inverting Output
27	GND	Ground
28	V _{EE}	Negative Supply Input. V _{EE} is generated by the MAX13170E. Bypass V _{EE} with a 1μF capacitor to ground.

+5V Multiprotocol, Software-Selectable Clock Transceiver

MAX13172E

Test Circuits

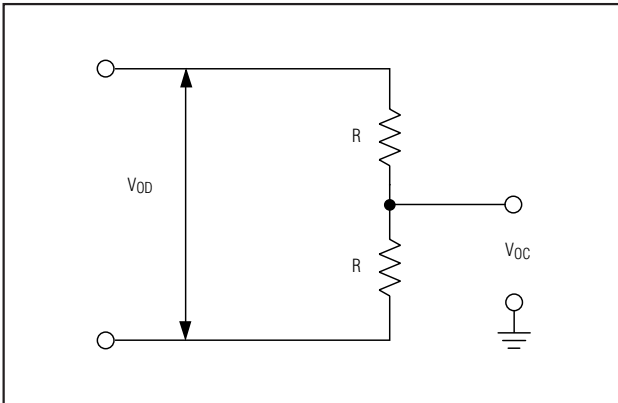

Figure 1. V.11 DC Test Circuit

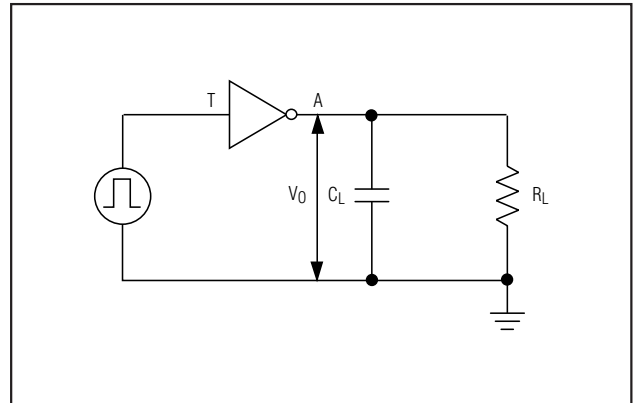

Figure 3. V.10/V.28 Transmitter Test Circuit

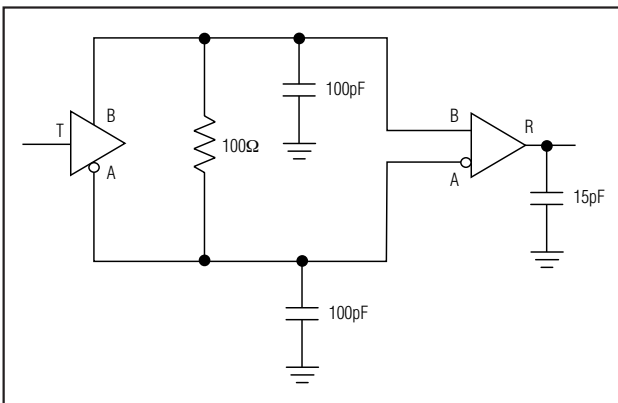

Figure 2. V.11 AC Test Circuit

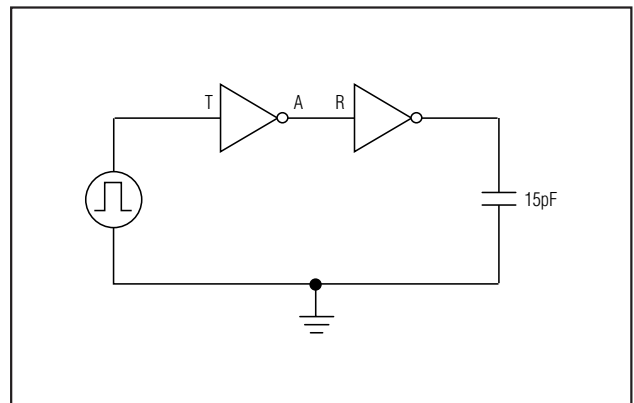

Figure 4. V.10/V.28 Receiver Test Circuit

Detailed Description

The MAX13172E is a four-driver/four-receiver, multiprotocol transceiver that operates from a single +5V supply. The charge pump operates from the MAX13170E. The MAX13172E along with the MAX13170E and MAX13174E, form a complete software-selectable DTE or DCE interface port that supports the V.28 (RS-232), V.10/V.11 (RS-449/V.36, EIA-530, EIA-530A, X.21, RS-423), and V.35 protocols. The MAX13172E usually carries the control signals. The MAX13170E carries the high-speed clock and data signals, and the MAX13174E provides termination for the clock and data signals.

The MAX13172E features an ultra-low supply current no-cable mode, fail-safe operation, and thermal-shut-

down circuitry. Thermal shutdown protects the transmitter and receiver outputs against excessive power dissipation. When activated, the thermal-shutdown circuitry places the driver outputs into a high-impedance state.

The state of the mode-select inputs M0, M1, and M2 determines which serial-interface protocol is selected (Table 1). The state of the DCE/DTE input determines whether the transceivers are configured as a DTE serial port or a DCE serial port. When the DCE/DTE input is logic-high, driver T3 is activated and receiver R1 is disabled. When the DCE/DTE input is logic-low, driver T3 is disabled and receiver R1 is activated. The INVERT input state changes the DCE/DTE functionality regarding T4 and R4 only. M0, M1, M2, INVERT, and DCE/DTE are internally pulled up to VCC to ensure logic-high if left unconnected.

+5V Multiprotocol, Software-Selectable Clock Transceiver

Switching Time Waveforms

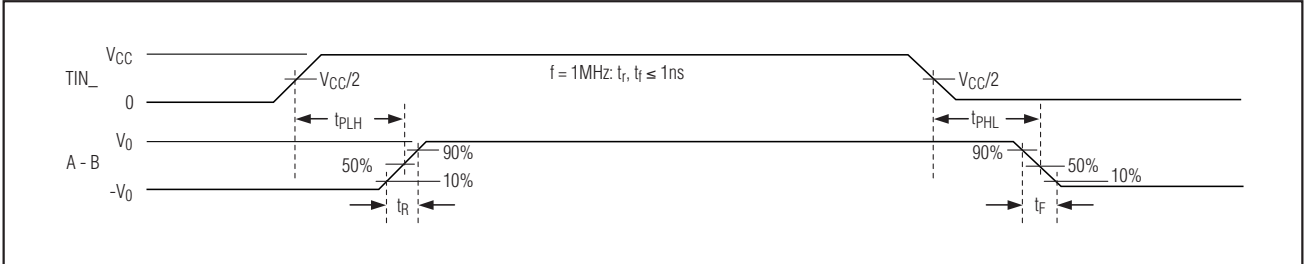

Figure 5. V.11 Transmitter Propagation Delays

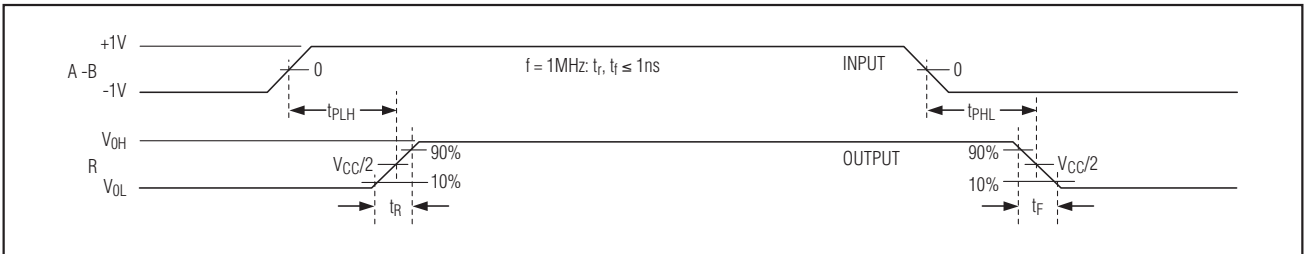

Figure 6. V.11 Receiver Propagation Delays

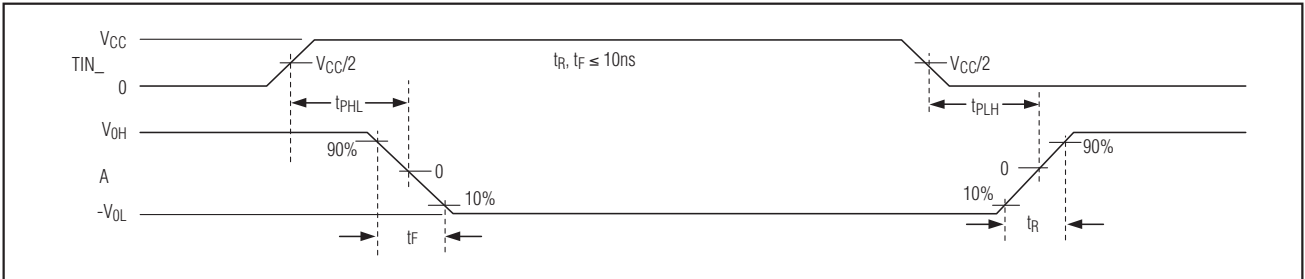

Figure 7. V.10 Transmitter Propagation Delays

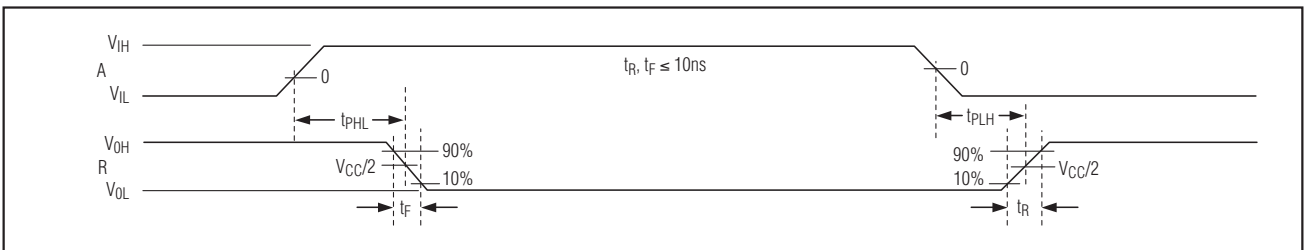

Figure 8. V.10 Receiver Propagation Delays

+5V Multiprotocol, Software-Selectable Clock Transceiver

MAX13172E

Switching Time Waveforms (continued)

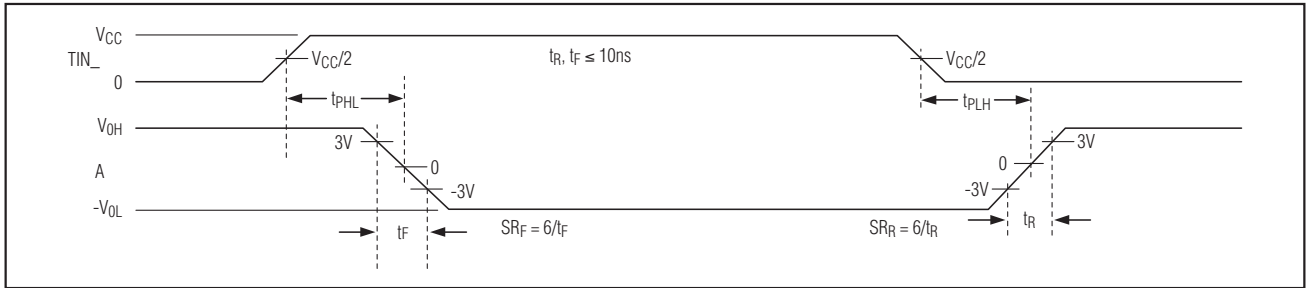

Figure 9. V.28 Transmitter Propagation Delays

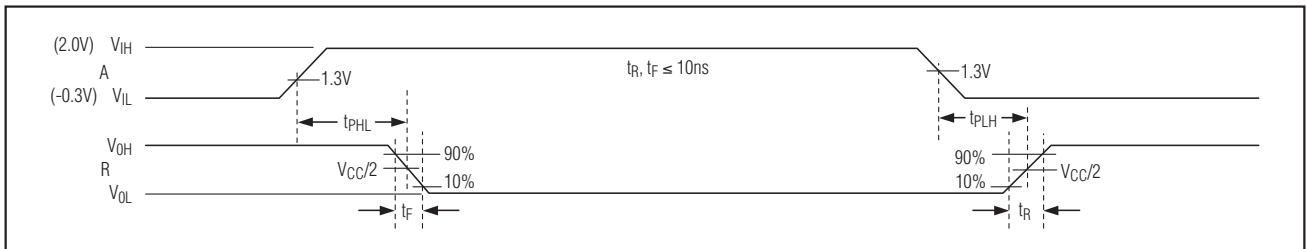

Figure 10. V.28 Receiver Propagation Delays

Table 1. Mode Select Table

PROTOCOL	M2	M1	M0	DCE/ DTE	INVERT	T1	T2	T3	R1	R2	R3	T4	R4
Not Used (Default V.11)	0	0	0	0	0	V.11	V.11	Z	V.11	V.11	V.11	Z	V.10
RS-530A	0	0	1	0	0	V.11	V.10	Z	V.11	V.10	V.11	Z	V.10
RS-530	0	1	0	0	0	V.11	V.11	Z	V.11	V.11	V.11	Z	V.10
X.21	0	1	1	0	0	V.11	V.11	Z	V.11	V.11	V.11	Z	V.10
V.35	1	0	0	0	0	V.28	V.28	Z	V.28	V.28	V.28	Z	V.28
RS-449/V.36	1	0	1	0	0	V.11	V.11	Z	V.11	V.11	V.11	Z	V.10
V.28/RS-232	1	1	0	0	0	V.28	V.28	Z	V.28	V.28	V.28	Z	V.28
No Cable	1	1	1	0	0	Z	Z	Z	Z	Z	Z	Z	Z
Not Used (Default V.11)	0	0	0	0	1	V.11	V.11	Z	V.11	V.11	V.11	V.10	Z
RS-530A	0	0	1	0	1	V.11	V.10	Z	V.11	V.10	V.11	V.10	Z
RS-530	0	1	0	0	1	V.11	V.11	Z	V.11	V.11	V.11	V.10	Z
X.21	0	1	1	0	1	V.11	V.11	Z	V.11	V.11	V.11	V.10	Z
V.35	1	0	0	0	1	V.28	V.28	Z	V.28	V.28	V.28	V.28	Z
RS-449/V.36	1	0	1	0	1	V.11	V.11	Z	V.11	V.11	V.11	V.10	Z
V.28/RS-232	1	1	0	0	1	V.28	V.28	Z	V.28	V.28	V.28	V.28	Z
No Cable	1	1	1	0	1	Z	Z	Z	Z	Z	Z	Z	Z

+5V Multiprotocol, Software-Selectable Clock Transceiver

Table 1. Mode Select Table (continued)

PROTOCOL	M2	M1	M0	DCE/ DTE	INVERT	T1	T2	T3	R1	R2	R3	T4	R4
Not Used (Default V.11)	0	0	0	1	0	V.11	V.11	V.11	Z	V.11	V.11	V.10	Z
RS-530A	0	0	1	1	0	V.11	V.10	V.11	Z	V.10	V.11	V.10	Z
RS-530	0	1	0	1	0	V.11	V.11	V.11	Z	V.11	V.11	V.10	Z
X.21	0	1	1	1	0	V.11	V.11	V.11	Z	V.11	V.11	V.10	Z
V.35	1	0	0	1	0	V.28	V.28	V.28	Z	V.28	V.28	V.28	Z
RS-449/V.36	1	0	1	1	0	V.11	V.11	V.11	Z	V.11	V.11	V.10	Z
V.28/RS-232	1	1	0	1	0	V.28	V.28	V.28	Z	V.28	V.28	V.28	Z
No Cable	1	1	1	1	0	Z	Z	Z	Z	Z	Z	Z	Z
Not Used (Default V.11)	0	0	0	1	1	V.11	V.11	V.11	Z	V.11	V.11	Z	V.10
RS-530A	0	0	1	1	1	V.11	V.10	V.11	Z	V.10	V.11	Z	V.10
RS-530	0	1	0	1	1	V.11	V.11	V.11	Z	V.11	V.11	Z	V.10
X.21	0	1	1	1	1	V.11	V.11	V.11	Z	V.11	V.11	Z	V.10
V.35	1	0	0	1	1	V.28	V.28	V.28	Z	V.28	V.28	Z	V.28
RS-449/V.36	1	0	1	1	1	V.11	V.11	V.11	Z	V.11	V.11	Z	V.10
V.28/RS-232	1	1	0	1	1	V.28	V.28	V.28	Z	V.28	V.28	Z	V.28
No Cable	1	1	1	1	1	Z	Z	Z	Z	Z	Z	Z	Z

The MAX13172E's mode can be selected through software control of the M0, M1, M2, INVERT, and DCE/DTE inputs. Alternatively, the mode can be selected by shorting the appropriate combination of mode control inputs to GND (the inputs left unconnected will be internally pulled up to VCC - logic-high). If the M0, M1, and M2 mode inputs are all unconnected, the MAX13172E will enter no-cable mode.

Fail-Safe

The MAX13172E guarantees a logic-high receiver output when the receiver inputs are shorted, or when they are connected to a terminated transmission line with all the drivers disabled. The V.11 receivers threshold is set between -200mV and -50mV to guarantee fail-safe operation. If the differential receiver input voltage (B - A) is \geq -50mV, ROUT is logic-high. In the case of a terminated bus with all transmitters disabled, the receiver's differential input voltage is pulled to 0 by the termination. With the receiver thresholds of the MAX13172E, this results in ROUT logic-high.

The V.10 receiver threshold is set between +50mV and +250mV. If the V.10 receiver input voltage is less than or equal to +250mV, ROUT is logic-high. The V.28 receiver threshold is set between 0.8V and 2.0V. If the receiver input voltage is less than or equal to 0.8V, ROUT is logic-high. In the case of a terminated bus with transmitters disabled, the receiver's input voltage is pulled to 0 by the termination.

ESD Protection

As with all Maxim devices, a minimum of ± 2 kV-to-GND ESD-protection structures are incorporated on all pins to protect against electrostatic discharges encountered during handling and assembly. The driver outputs and receiver inputs of the MAX13172E have extra protection against static electricity. Maxim's engineers have developed state-of-the-art structures to protect these pins against ESD of ± 10 kV without damage (HBM). The ESD structures withstand high ESD in all states: normal operation, shutdown, and powered down. After an ESD event, the MAX13172E keeps working without latchup or damage. ESD protection can be tested in various ways. The transmitter outputs and receiver inputs of the MAX13172E are characterized for protection to the following limits:

- ± 10 kV using the Human Body Model
- ± 3 kV using the Contact Method specified in IEC 61000-4-2
- ± 3 kV using the Air Gap Discharge Method specified in IEC 61000-4-2

ESD Test Conditions

ESD performance depends on a variety of conditions. Contact Maxim for a reliability report that documents test setup, test methodology, and test results.

+5V Multiprotocol, Software-Selectable Clock Transceiver

MAX13172E

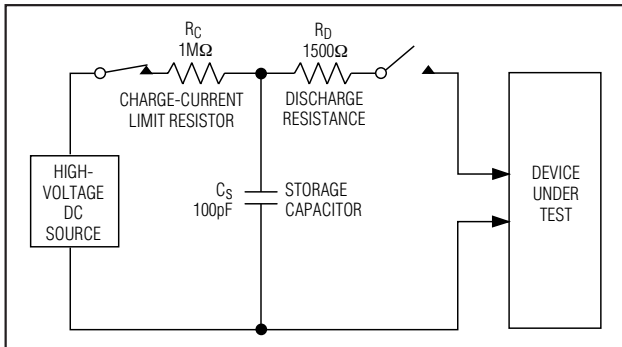

Figure 11a. Human Body ESD Test Model

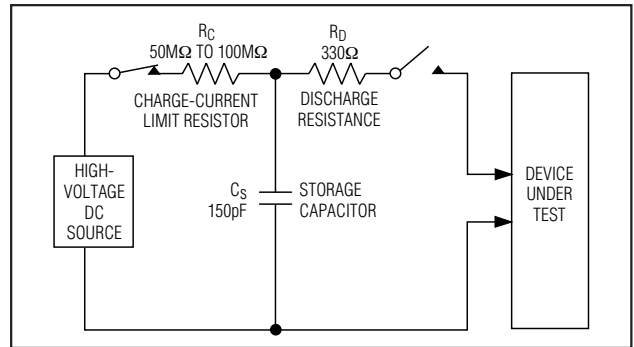

Figure 11c. IEC 61000-4-2 ESD Test Model

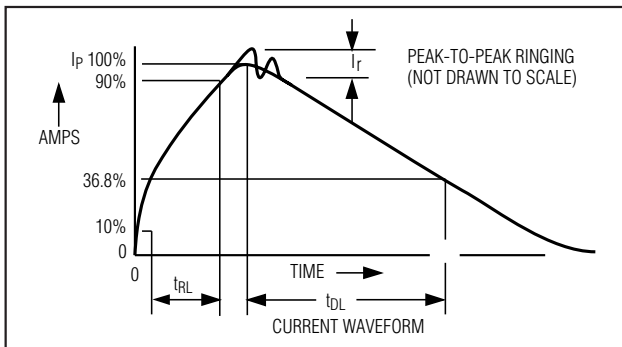

Figure 11b. Human Body Current Waveform

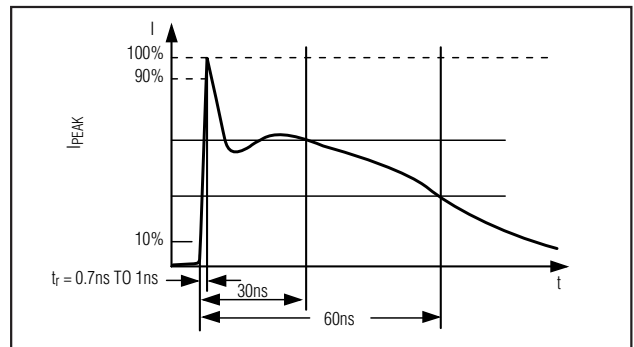

Figure 11d. IEC 61000-4-2 ESD Generator Current Waveform

Human Body Model

Figure 11a shows the Human Body Model, and Figure 11b shows the current waveform it generates when discharged into a low impedance. This model consists of a 100pF capacitor charged to the ESD voltage of interest, which is then discharged into the test device through a 1.5kΩ resistor.

IEC 61000-4-2

The IEC 61000-4-2 standard covers ESD testing and performance of finished equipment. However, it does not specifically refer to integrated circuits. The MAX13172E helps equipment designs meet IEC 61000-4-2, without the need for additional ESD-protection components.

The major difference between tests done using the Human Body Model and IEC 61000-4-2 is higher peak current in IEC 61000-4-2 because series resistance is lower in the IEC 61000-4-2 model. Hence, the ESD withstand voltage measured to IEC 61000-4-2 is generally lower than that measured using the Human Body Model. Figure 11c shows the IEC 61000-4-2 model, and Figure 11d shows the current waveform for the IEC 61000-4-2 ESD Contact Discharge test.

+5V Multiprotocol, Software-Selectable Clock Transceiver

Applications Information

Cable-Selectable Configuration Application

A cable-selectable, multiprotocol DTE/DCE interface is shown in Figure 12. The mode control lines M0, M1, and DCE/ $\overline{\text{DTE}}$ are wired to the DB-25 connector. To select the serial-interface mode, the appropriate combination of M0, M1, M2, and DCE/ $\overline{\text{DTE}}$ are grounded within the cable wiring. The control lines that are not grounded are pulled high by the internal pullups on the MAX13170E. The serial-interface protocol of the MAX13172E is now selected based on the cable that is connected to the DB-25 interface.

V.10 (RS-423) Interface

The V.10 interface (Figure 13) is an unbalanced single-ended interface capable of driving a 450 Ω load. The V.10 driver generates a minimum V_O voltage of $\pm 4V$ across A' and C' when unloaded and a minimum voltage of $0.9 \times V_O$ when loaded with 450 Ω . The V.10 receiver has a single-ended input and does not reject common-mode differences between C and C'. The V.10 receiver input trip threshold is defined between +250mV and -250mV with input impedance characteristic shown in Figure 14.

The MAX13172E V.10 mode receiver has a threshold between +50mV and -250mV. To ensure that the receiver has proper fail-safe operation see the *Fail-Safe* section. To aid in rejecting system noise, the MAX13172E V.10 receiver has a typical hysteresis of 25mV. Switch S3 in Figures 16a and 16b is open in V.10 mode to disable the V.28 5k Ω termination at the receiver input. Switch S2 is closed and switch S1 is open to internally ground the receiver B input.

V.11 (RS-422) Interface

As shown in Figure 16, the V.11 protocol is a fully balanced differential interface. The V.11 driver generates a minimum of $\pm 2V$ between nodes A and B when 100 Ω minimum resistance is presented at the load. The V.11 receiver is sensitive to differential signals of $\pm 200mV$ at receiver inputs A' and B'. The V.11 receiver input must comply with the impedance curve of Figure 14 and reject common-mode signals developed across the cable (referenced from C to C' in Figure 16) of up to $\pm 7V$.

The MAX13172E V.11 mode receiver has a differential threshold between -50mV and -200mV. To ensure that the receiver has proper fail-safe operation; see the *Fail-Safe* section. To aid in rejecting system noise, the MAX13172E V.11 receiver has a typical hysteresis of 15mV. Switch S3 in Figure 17 is open in V.11 mode to

disable the V.28 5k Ω termination at the inverting receiver input. Because the control signals are slow (60kbps), 100 Ω termination resistance is generally not required for the MAX13172E. The receiver inputs must also be compliant with the impedance curve shown in Figure 14.

V.28 (RS-232) Interface

The V.28 interface is an unbalanced single-ended interface (Figure 13). The V.28 generator provides a minimum of $\pm 5V$ across the 3k Ω load impedance between A' and C'. The V.28 receiver has a single-ended input.

The MAX13172E V.28 mode receiver has a threshold between +0.8V and +2.0V. To aid in rejecting system noise, the MAX13172E V.28 receiver has a typical hysteresis of 0.25V. Switch S3 in Figures 18a and 18b is closed in V.28 mode to enable the 5k Ω V.28 termination at the receiver inputs.

No-Cable Mode

The MAX13172E will enter no-cable mode when the mode-select pins are left unconnected or connected high (M0 = M1 = M2 = 1). In this mode, the multiprotocol drivers and receivers are disabled and the supply current is less than 10 μA . The receiver outputs enter a high-impedance state in no-cable mode, which allows these output lines to be shared with other receiver outputs (the receiver outputs have an internal pullup resistor to pull the outputs high if not driven). Also, in no-cable mode, the transmitter outputs enter a high-impedance state, so these output lines can be shared with other devices.

DTE vs. DCE Operation

Figure 19 shows a port with one DB-25 connector that can be configured for either DTE or DCE operation. The configuration requires separate cables for proper signal routing in DTE or DCE operation. Figure 16 illustrates a DCE or DTE controller-selectable interface. The DCE/ $\overline{\text{DTE}}$ and INVERT inputs switch the port's mode of operation (Table 1).

The MAX13170E and MAX13172E can be connected for either DTE or DCE operation in one of two ways: a dedicated DTE or DCE port with an appropriate gender connector or a port with a connector that can be configured for DTE or DCE operation by rerouting the signals to the MAX13170E and MAX13172E using a dedicated DTE cable or dedicated DCE cable. The interface mode is selected by logic outputs from the controller or from jumpers to either V_{CC} or GND on the mode select pins. A dedicated DCE port using a DB-25 female connector is shown in Figure 20. Figure 21 illustrates a dedicated DTE port using a DB-25 male connector.

+5V Multiprotocol, Software-Selectable Clock Transceiver

MAX13172E

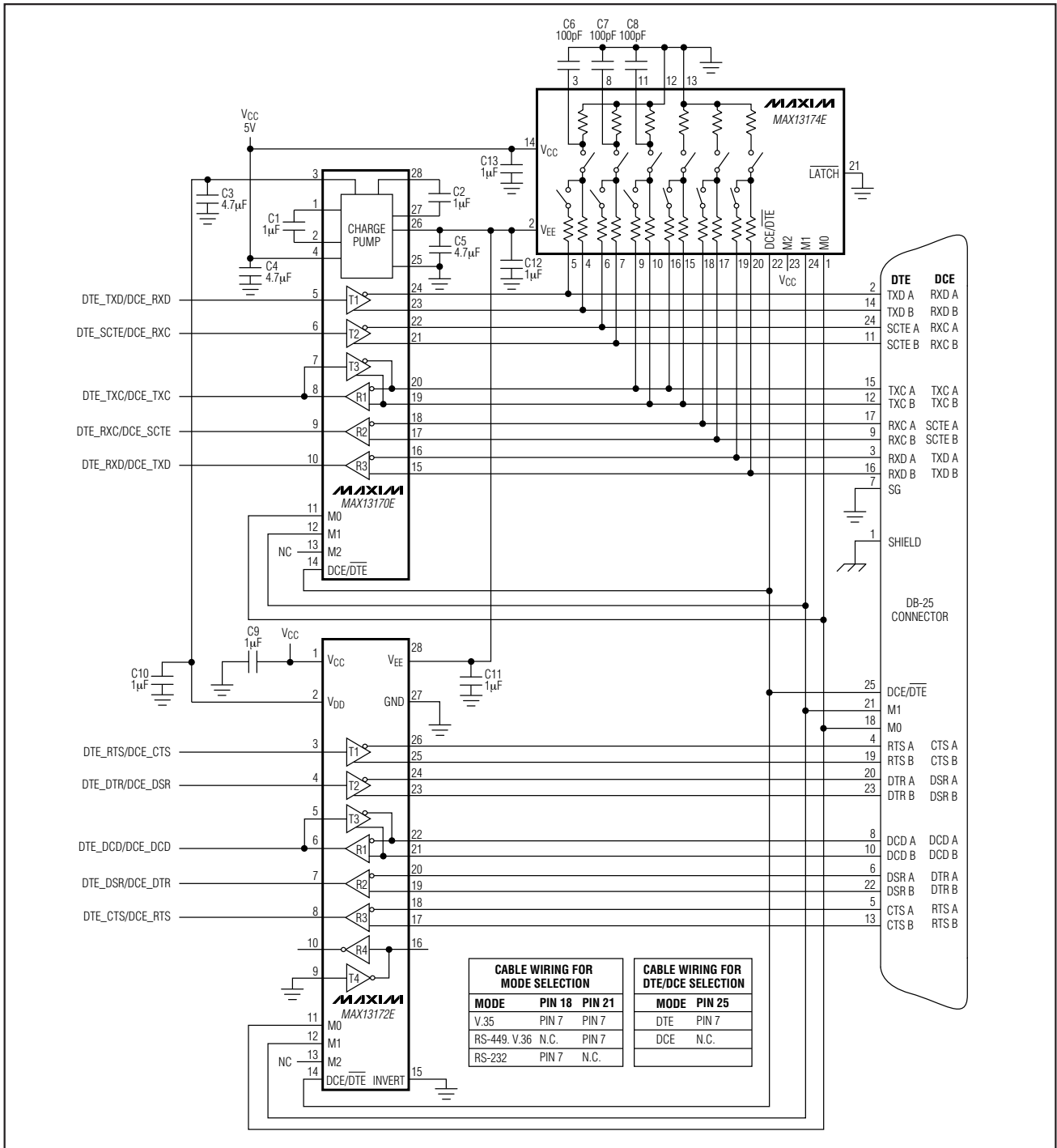

Figure 12. Cable-Selectable Multiprotocol DTE/DCE Port

+5V Multiprotocol, Software-Selectable Clock Transceiver

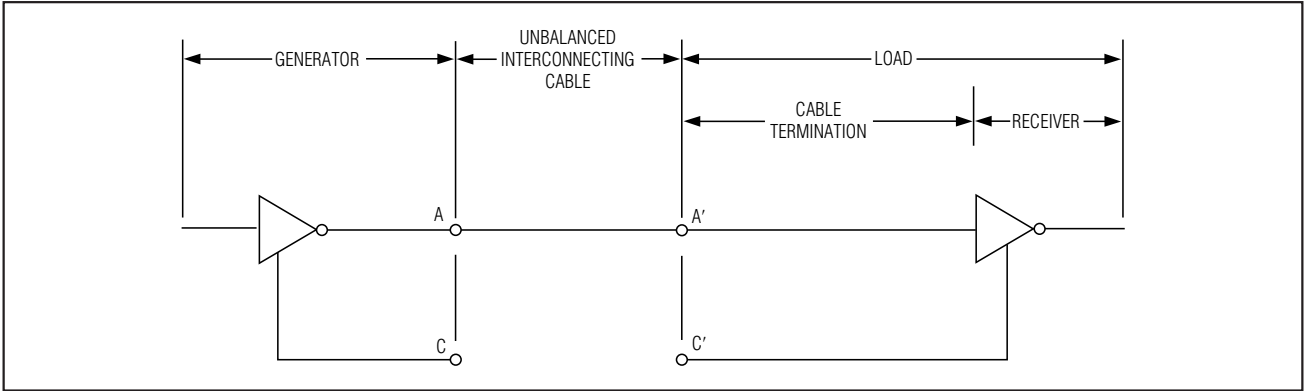

Figure 13. Typical V.10/V.28 Interface

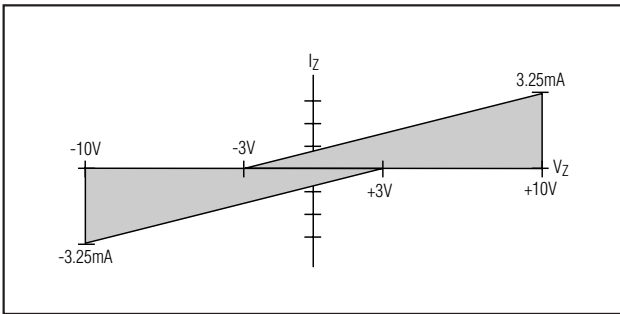

Figure 14. Receiver Input Impedance Curve

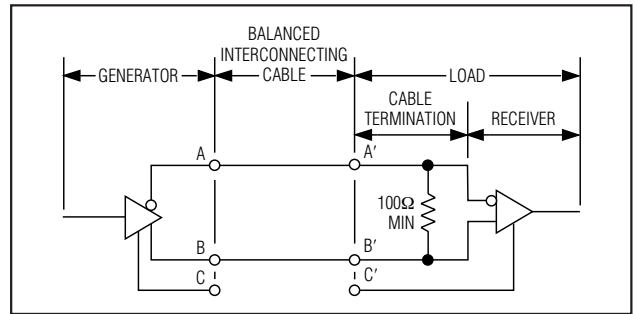

Figure 15. Typical V.11 Interface

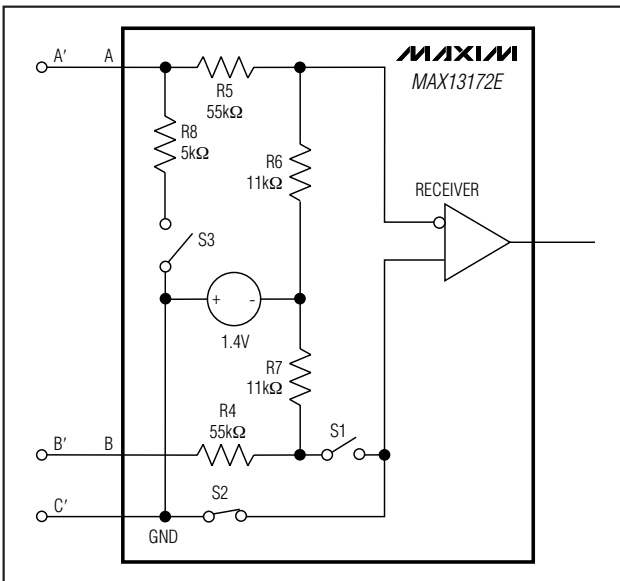

Figure 16a. V.10 Internal Resistance Network for Receivers 1, 2, and 3

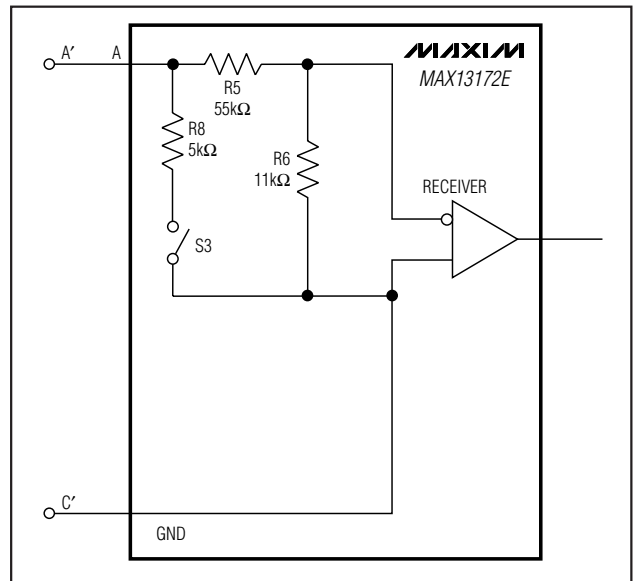

Figure 16b. V.10 Internal Resistance Network for Receiver 4

+5V Multiprotocol, Software-Selectable Clock Transceiver

MAX13172E

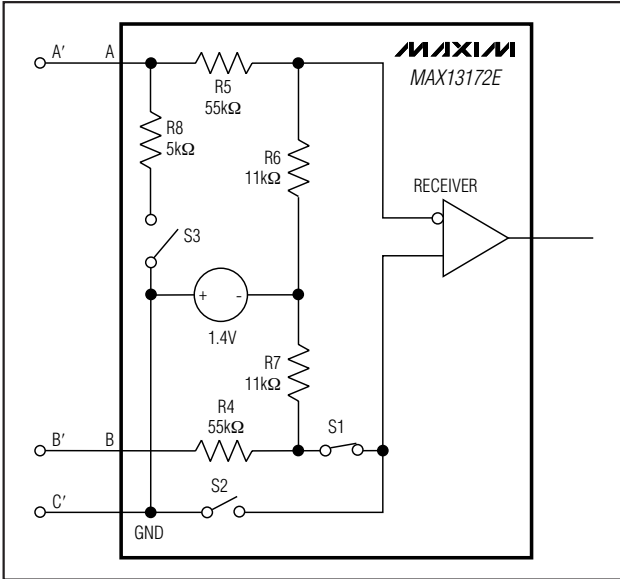

Figure 17. V.11 Internal Resistance Networks

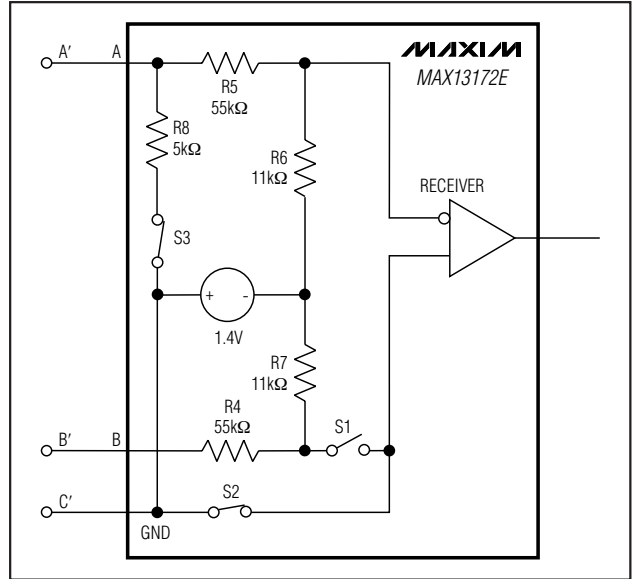

Figure 18a. V.28 Internal Resistance Network for Receiver 1, 2, and 3

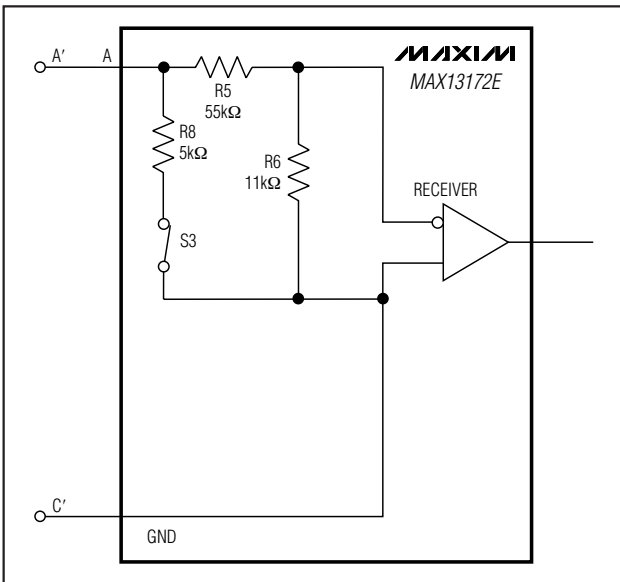

Figure 18b. V.28 Internal Resistance Network for Receiver 4

+5V Multiprotocol, Software-Selectable Clock Transceiver

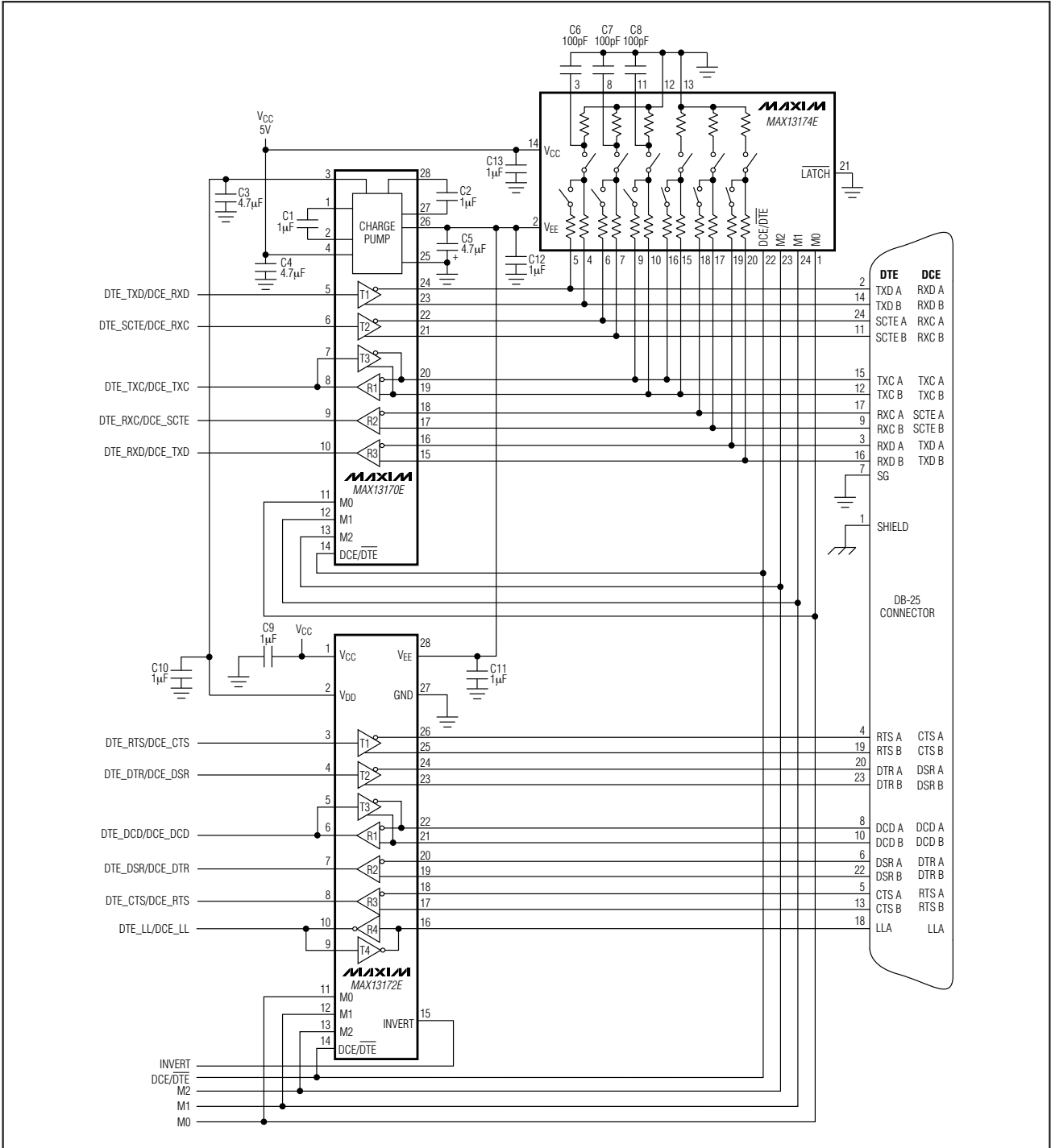

Figure 19. Controller-Selectable Multiprotocol DCE/DTE Port with DB-25 Connector

+5V Multiprotocol, Software-Selectable Clock Transceiver

MAX13172E

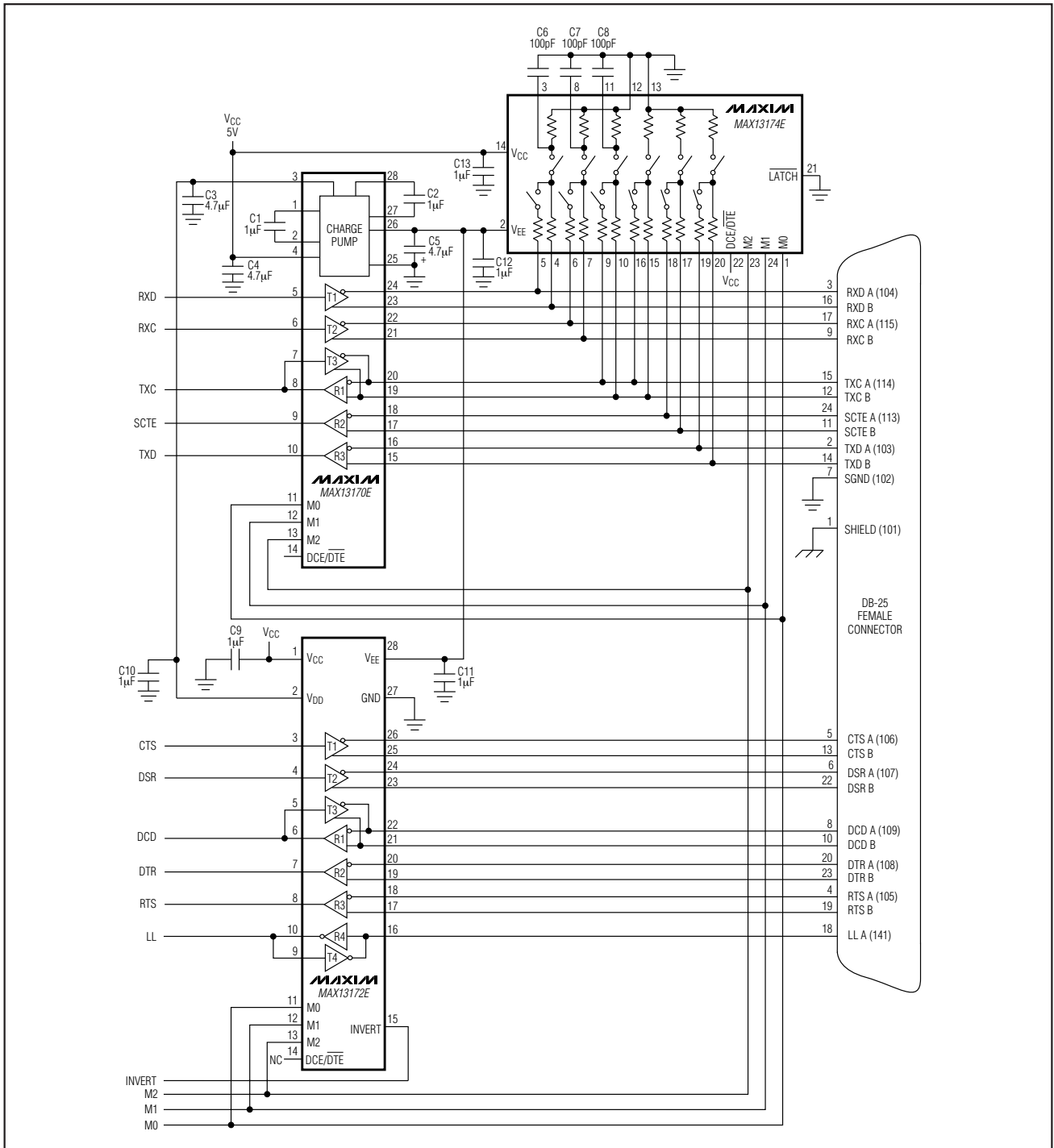

Figure 20. Controller-Selectable DCE Port with DB-25 Connector

+5V Multiprotocol, Software-Selectable Clock Transceiver

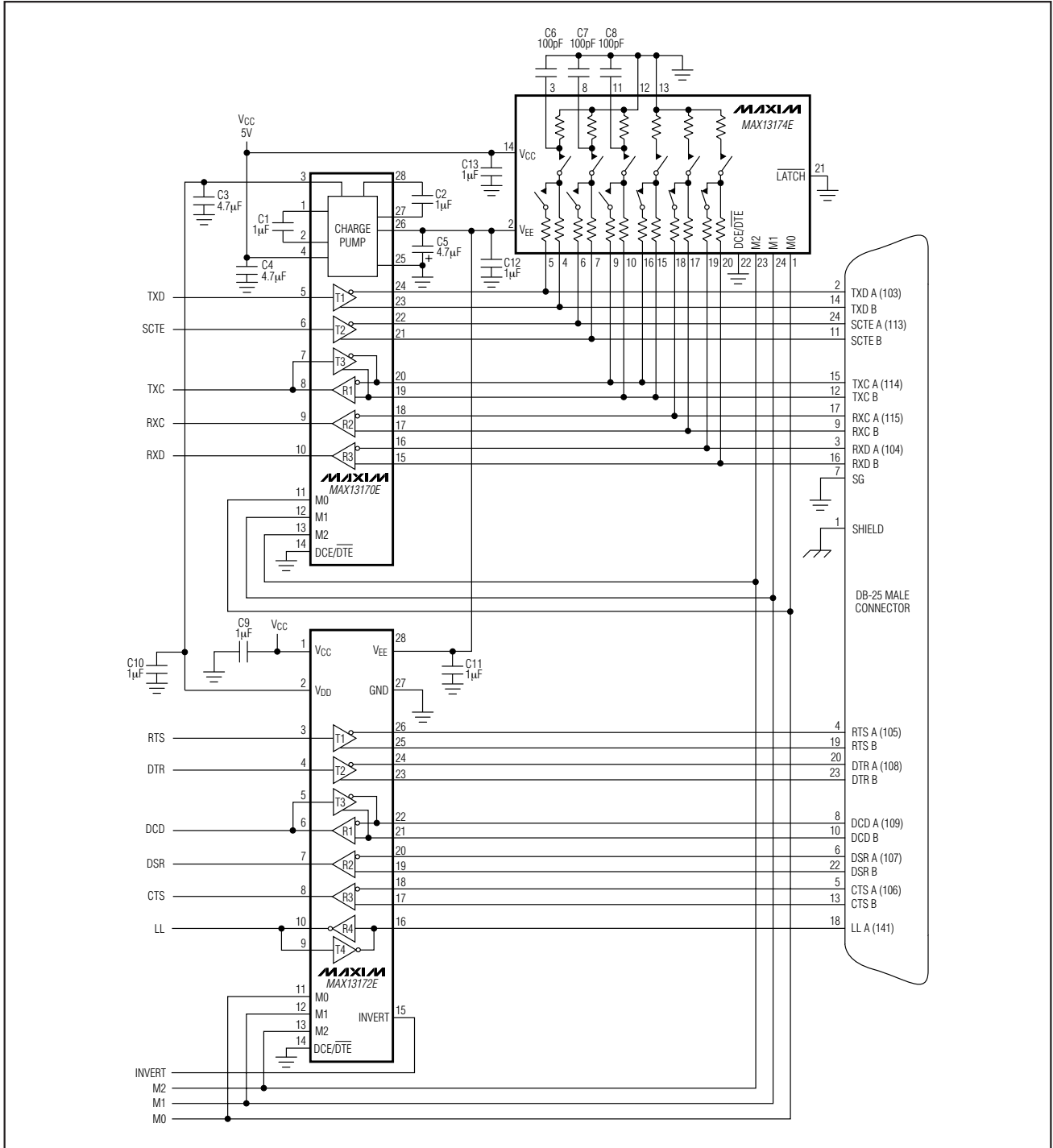
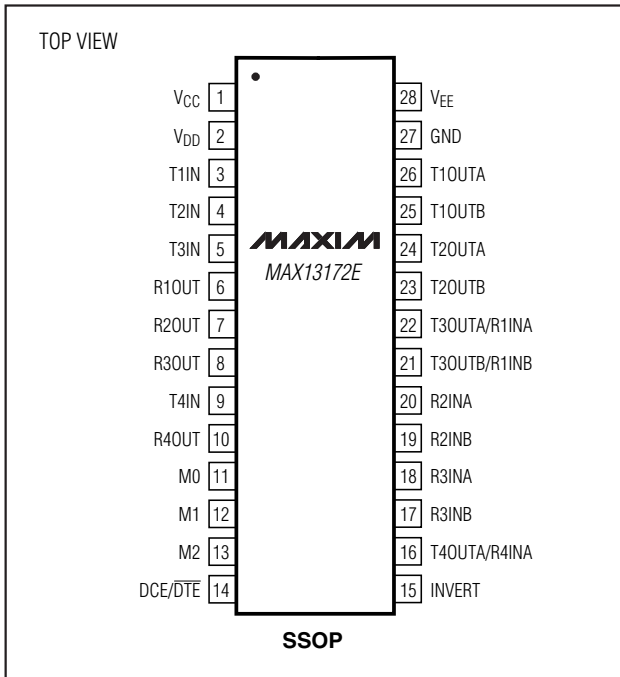

Figure 21. Controller-Selectable Multiprotocol DTE Port with DB-25 Connector

+5V Multiprotocol, Software-Selectable Clock Transceiver

MAX13172E

Pin Configuration



Chip Information

TRANSISTOR COUNT: 2348
PROCESS: BiCMOS

Package Information

For the latest package outline information, go to www.maxim-ic.com/packages.

PACKAGE TYPE	PACKAGE CODE	DOCUMENT NO.
28 SSOP	A28-2	21-0056

Maxim cannot assume responsibility for use of any circuitry other than circuitry entirely embodied in a Maxim product. No circuit patent licenses are implied. Maxim reserves the right to change the circuitry and specifications without notice at any time.

Maxim Integrated Products, 120 San Gabriel Drive, Sunnyvale, CA 94086 408-737-7600 _____ 21