

### FEATURES:

- 16K x 9-bit organization
- RAD-PAK® radiation-hardened against natural space radiation
- A total dose hardness:
  - > 100 krad (Si), depending upon space mission
- Excellent Single Event Effect
  - SEL<sub>TH</sub>: > 100 MeV/mg/cm<sup>2</sup>
  - SEU<sub>TH</sub>: = 7 MeV/mg/cm<sup>2</sup>
  - SEU saturated cross section: 1.5E-5 cm<sup>2</sup>/bit
- Asynchronous Read/Write operation
- High speed CMOS epi technology
- Retransmit capability
- Propagation time (max access time):
  - 15 ns, 20 ns, 30 ns, 40 ns, 50 ns
- Status flag: empty, half-full, full
- Fully expandable in both word depth and width
- Bi-directional applications
- Low power
- Battery back-up operation
- TTL compatible
- Package: 28 pin RAD-PAK® flat package

### DESCRIPTION:

Maxwell Technologies' 7206F high speed FIFO microcircuit features a greater than 100 krad (Si) total dose tolerance, depending upon space mission. It is organized such that the data is read in the same sequential order that it was written. Full and Empty flags are provided to prevent overflow and underflow. The expansion logic allows unlimited expansion capability in work size and depth with no timing penalties. Twin address pointers automatically generate internal read and write addresses, and automatically increment with the write and read pin. The 7206F 9-bits wide data are used in data communications applications where a parity bit for error checking is necessary. The retransmit capability allows the read pointer to be reset to its initial position without affecting the write pointer.

Maxwell Technologies' patented RAD-PAK® packaging technology incorporates radiation shielding in the microcircuit package. It eliminates the need for box shielding while providing the required radiation shielding for a lifetime in orbit or space mission. In a GEO orbit, RAD-PAK provides greater than 100 krad (Si) radiation dose tolerance. This product is available with screening up to Class S.

TABLE 1. 7206F PINOUT DESCRIPTION

PIN	SYMBOL	DESCRIPTION
1	$\overline{W}$	Write Enable
2 - 6	I8, I3-I0	Inputs
7	$\overline{XI}$	Expansion In
8	FF	Full Flag
9 - 13	Q0 - Q3, Q8	Outputs
14	GND	Ground
15	$\overline{R}$	Read Enable
16 - 19	Q4 - Q7	Outputs
20	$\overline{XO/HF}$	Expansion Out/Half Full Flag
21	$\overline{EF}$	Empty Flag
22	$\overline{RS}$	Reset
23	$\overline{FL/RT}$	First Load/Retransmit
24 - 27	I7 - I4	Inputs
28	$V_{CC}$	Power Supply

TABLE 2. 7206F ABSOLUTE MAXIMUM RATINGS

PARAMETER	SYMBOL	MIN	MAX	UNIT
Positive Supply Voltage	$V_{CC}$	-0.3	7.0	V
Input or Output Voltage	$V_{IN}$	GND -0.3	$V_{CC} + 0.3$	V
Storage Temperature Range	$T_S$	-65	150	°C
Operating Temperature Range	$T_A$	-55	125	°C

TABLE 3. 7206F RECOMMENDED OPERATING CONDITIONS

PARAMETER	SYMBOL	MIN	MAX	UNIT
Positive Supply Voltage	$V_{CC}$	4.5	5.5	V
High Level Input Voltage	$V_{IH}$	2.2	--	V
Low Level Voltage	$V_{IL}$	--	0.8	V
Thermal Impedance	$\Theta_{JC}$	--	0.93	°C/W
Operating Temperature Range	$T_A$	-55	125	°C

TABLE 4. 7206F DC ELECTRICAL CHARACTERISTICS  
( $V_{CC} = 5V \pm 10\%$ ,  $T_A = -55$  TO  $+125$  °C UNLESS OTHERWISE SPECIFIED)

PARAMETER	SYMBOL	MIN	MAX	UNIT
Operating Supply Current	$I_{CCOP}$	--	165	mA
-15		--	160	
-20		--	150	
-30		--	140	
-40		--	130	
-50		--	130	
Standby Supply Current ( $\overline{R} = \overline{W} = \overline{RS} = \overline{FLVRT} = V_{IH}$ )	$I_{CCSB}$	--	5	mA
Power Down Current (All Input = $V_{CC}$ )	$I_{CCPD}$	--	400	$\mu$ A
Input Leakage Current ( $0.4V \leq V_{IN} \leq V_{CC}$ )	$I_{LI}$	--	$\pm 1$	$\mu$ A
Output Leakage Current ( $\overline{R} = V_{IH}$ , $0.4V \leq V_{OUT} \leq V_{CC}$ )	$I_{LO}$	--	$\pm 1$	$\mu$ A
Input Low Voltage <sup>1</sup>	$V_{IL}$	--	0.8	V
Input High Voltage <sup>1</sup>	$V_{IH}$	2.2	--	V
Output Low Voltage ( $V_{CC}$ min, $I_{OL} = 8mA$ )	$V_{OL}$	--	0.4	V
Output High Voltage ( $V_{CC}$ min, $I_{OH} = -2mA$ )	$V_{OH}$	2.4	--	V
Input Capacitance <sup>2</sup>	$C_{IN}$	--	10	pF
Output Capacitance <sup>2</sup>	$C_{OUT}$	--	10	pF

1.  $V_{IH}$  max =  $V_{CC} + 0.3V$ .  $V_{IL}$  min = -0.3V or -1.0V pulse width 50 ns.
2. Guaranteed by design.

TABLE 5. 7206F TIMING CHARACTERISTICS <sup>1</sup>  
( $V_{CC} = 5V \pm 10\%$ ,  $T_A = -55$  TO  $+125$  °C UNLESS OTHERWISE SPECIFIED)

PARAMETER	SYMBOL	MIN	MAX	UNITS
Read Cycle				
Read Cycle Time	$t_{RC}$	25	--	ns
-15		30	--	
-20		40	--	
-30		50	--	
-40		65	--	
-50		65	--	
Access Time	$t_A$	--	15	ns
-15		--	20	
-20		--	30	
-30		--	40	
-40		--	50	
-50		--	50	

# High-Speed Epi-CMOS (16K x 9-Bit) Parallel FIFO

# 7206F

TABLE 5. 7206F TIMING CHARACTERISTICS <sup>1</sup>  
 (V<sub>CC</sub> = 5V ± 10%, T<sub>A</sub> = -55 TO +125 °C UNLESS OTHERWISE SPECIFIED)

PARAMETER	SYMBOL	MIN	MAX	UNITS
Read Recovery Time	t <sub>RR</sub>			ns
-15		10	--	
-20		10	--	
-30		10	--	
-40		10	--	
-50		15	--	
Read Pulse Width <sup>2</sup>	t <sub>RPW</sub>			ns
-15		15	--	
-20		20	--	
-30		30	--	
-40		40	--	
-50		50	--	
Read Low to Data Low-Z <sup>3</sup>	t <sub>RLZ</sub>			ns
-15		0	--	
-20		0	--	
-30		5	--	
-40		5	--	
-50		5	--	
Write HIGH to Data Low-Z <sup>3,4</sup>	t <sub>WLZ</sub>			ns
-15		3	--	
-20		3	--	
-30		5	--	
-40		5	--	
-50		5	--	
Data Valid from Read High	t <sub>DV</sub>			ns
-15		5	--	
-20		5	--	
-30		5	--	
-40		5	--	
-50		5	--	
Read High to Data Bus High-Z <sup>3</sup>	t <sub>RHZ</sub>			ns
-15		--	15	
-20		--	15	
-30		--	20	
-40		--	25	
-50		--	30	

# High-Speed Epi-CMOS (16K x 9-Bit) Parallel FIFO

# 7206F

TABLE 5. 7206F TIMING CHARACTERISTICS <sup>1</sup>  
 (V<sub>CC</sub> = 5V ± 10%, T<sub>A</sub> = -55 TO +125 °C UNLESS OTHERWISE SPECIFIED)

PARAMETER	SYMBOL	MIN	MAX	UNITS
<b>Write Cycle</b>				
Write Cycle Time	t <sub>WC</sub>			ns
-15		25	--	
-20		30	--	
-30		40	--	
-40		50	--	
-50		65	--	
Write Pulse Width <sup>2</sup>	t <sub>WPW</sub>			ns
-15		15	--	
-20		20	--	
-30		30	--	
-40		40	--	
-50		50	--	
Write Recovery Time	t <sub>WR</sub>			ns
-15		10	--	
-20		10	--	
-30		10	--	
-40		10	--	
-50		15	--	
Data Set-up Time	t <sub>DS</sub>			ns
-15		9	--	
-20		12	--	
-30		18	--	
-40		24	--	
-50		30	--	
Data Hold Time	t <sub>DH</sub>			ns
-15		0	--	
-20		0	--	
-30		0	--	
-40		0	--	
-50		5	--	
<b>Reset Cycle</b>				
Reset Cycle Time	t <sub>RSC</sub>			ns
-15		25	--	
-20		30	--	
-30		40	--	
-40		50	--	
-50		65	--	
Reset Pulse Width <sup>2</sup>	t <sub>RS</sub>			ns
-15		15	--	
-20		20	--	
-30		30	--	
-40		40	--	
-50		50	--	

TABLE 5. 7206F TIMING CHARACTERISTICS <sup>1</sup>  
 (V<sub>CC</sub> = 5V ± 10%, T<sub>A</sub> = -55 TO +125 °C UNLESS OTHERWISE SPECIFIED)

PARAMETER	SYMBOL	MIN	MAX	UNITS
Reset Set-up Time <sup>3</sup>	t <sub>RSS</sub>			ns
-15		20	--	
-20		30	--	
-30		30	--	
-40		50	--	
-50		60	--	
Reset Recovery Time	t <sub>RSR</sub>			ns
-15		10	--	
-20		10	--	
-30		10	--	
-40		10	--	
-50		15	--	
Retransmit Cycle				
Retransmit Cycle Time	t <sub>RTC</sub>			ns
-15		25	--	
-20		30	--	
-30		40	--	
-40		50	--	
-50		65	--	
Retransmit Pulse Width <sup>2</sup>	t <sub>RT</sub>			ns
-15		15	--	
-20		20	--	
-30		30	--	
-40		40	--	
-50		50	--	
Retransmit Set-up Time <sup>3</sup>	t <sub>RTS</sub>			ns
-15		15	--	
-20		20	--	
-30		30	--	
-40		40	--	
-50		50	--	
Retransmit Recovery Time	t <sub>RTR</sub>			ns
-15		10	--	
-20		10	--	
-30		10	--	
-40		10	--	
-50		15	--	
Flags				
Reset to $\overline{EF}$ Low	t <sub>EFL</sub>			ns
-15		--	25	
-20		--	30	
-30		--	30	
-40		--	50	
-50		--	65	

# High-Speed Epi-CMOS (16K x 9-Bit) Parallel FIFO

# 7206F

TABLE 5. 7206F TIMING CHARACTERISTICS <sup>1</sup>  
 (V<sub>CC</sub> = 5V ± 10%, T<sub>A</sub> = -55 TO +125 °C UNLESS OTHERWISE SPECIFIED)

PARAMETER	SYMBOL	MIN	MAX	UNITS
Reset to HF/FF High -15 -20 -30 -40 -50	t <sub>HFH</sub> , t <sub>FFH</sub>	--	25 30 30 50 65	ns
Read Low to EF Low -15 -20 -30 -40 -50	t <sub>REF</sub>	--	15 20 30 40 50	ns
Read High to FF High -15 -20 -30 -40 -50	t <sub>RFF</sub>	--	17 20 30 40 50	ns
Read Pulse Width after EF High -15 -20 -30 -40 -50	t <sub>RPE</sub>	15 20 30 40 50	-- -- -- -- --	ns
Write High to EF High -15 -20 -30 -40 -50	t <sub>WEF</sub>	--	15 20 30 40 50	ns
Write Low to FF Low -15 -20 -30 -40 -50	t <sub>WFF</sub>	--	20 20 30 40 50	ns
Write Low to HF Flag Low -15 -20 -30 -40 -50	t <sub>WHF</sub>	--	30 30 30 50 65	ns

TABLE 5. 7206F TIMING CHARACTERISTICS <sup>1</sup>  
 (V<sub>CC</sub> = 5V ± 10%, T<sub>A</sub> = -55 to +125 °C UNLESS OTHERWISE SPECIFIED)

PARAMETER	SYMBOL	MIN	MAX	UNITS
Read High to $\overline{\text{HF}}$ Flag High -15 -20 -30 -40 -50	t <sub>RHF</sub>	-- -- -- -- --	30 30 30 50 65	ns
Write Pulse Width after $\overline{\text{FF}}$ High -15 -20 -30 -40 -50	t <sub>WPF</sub>	15 20 30 40 50	-- -- -- -- --	ns
Read/Write LOW to $\overline{\text{XO}}$ LOW -15 -20 -30 -40 -50	t <sub>XOL</sub>	-- -- -- -- --	15 20 30 40 50	ns
Read/Write LOW to $\overline{\text{XO}}$ HIGH -15 -20 -30 -40 -50	t <sub>XOH</sub>	-- -- -- -- --	15 20 30 40 50	ns
$\overline{\text{XI}}$ Pulse Width -15 -20 -30 -40 -50	t <sub>XI</sub>	15 20 30 40 50	-- -- -- -- --	ns
$\overline{\text{XI}}$ Recovery Time -15 -20 -30 -40 -50	t <sub>XIR</sub>	10 10 10 10 10	-- -- -- -- --	ns
$\overline{\text{XI}}$ Set-up Time -15 -20 -30 -40 -50	t <sub>XIS</sub>	10 10 10 15 15	-- -- -- -- --	ns

1. V<sub>CC</sub> = +5V±10%, T<sub>A</sub> = +25 °C; use switching test circuit. AC tests are performed with input rise and fall times of 5 ns or less, timing reference levels of 1.5V, input pulse levels of 0 to 3.0V and the output load circuit, unless otherwise specified.



2. Pulse widths less than minimum value are not allowed.
3. Values guaranteed by design, not currently tested.
4. Only applies to read data flow-through mode.

FIGURE 1. RESET

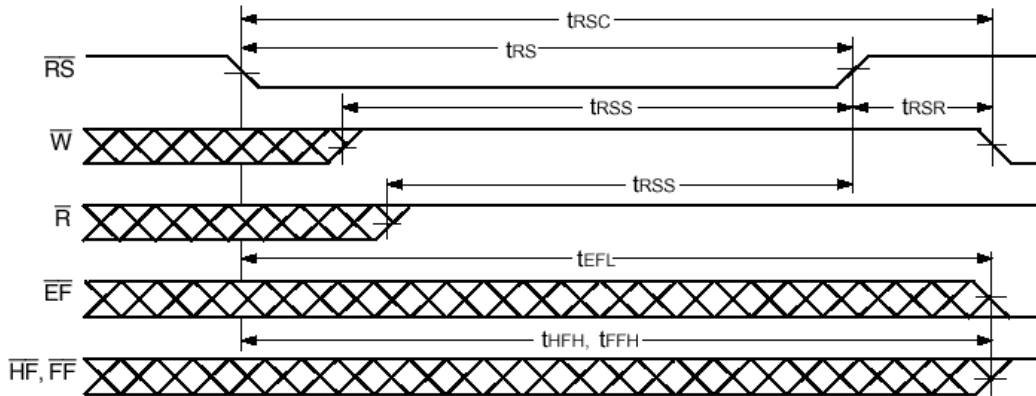

FIGURE 2. ASYNCHRONOUS WRITE AND READ OPERATION

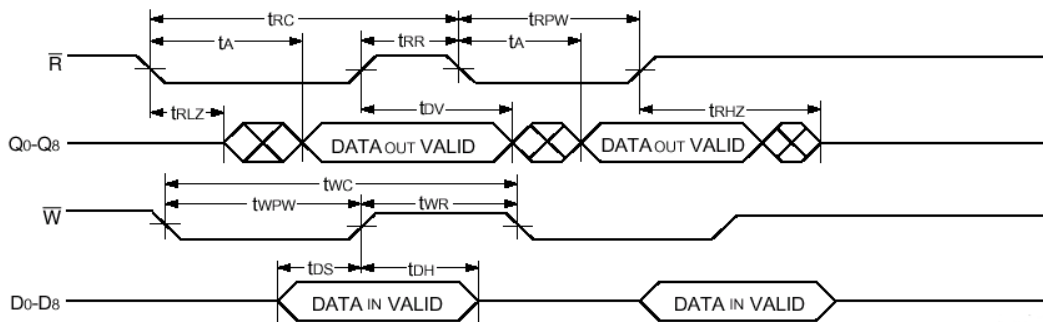

FIGURE 3. FULL FLAG TIMING FROM LAST WRITE TO FIRST READ

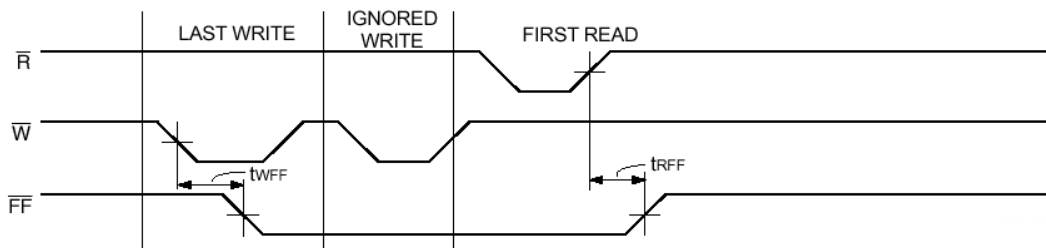

FIGURE 4. EMPTY FLAG TIMING FROM LAST READ TO FIRST WRITE

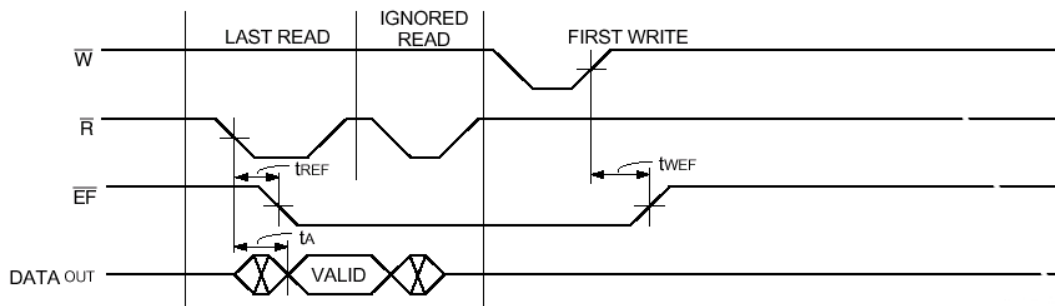
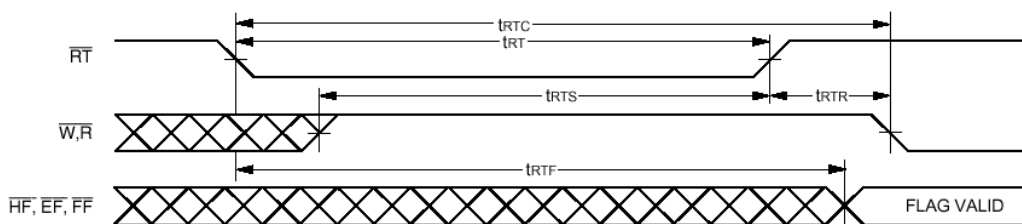

FIGURE 5. RETRANSMIT



**NOTE:**  
1. EF, FF and HF may change status during Retransmit, but flags will be valid at tRTC.

FIGURE 6. EMPTY FLAG TIMING

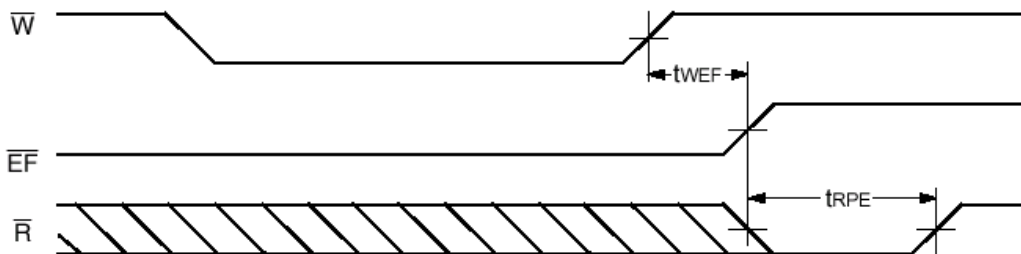

FIGURE 7. FULL FLAG TIMING

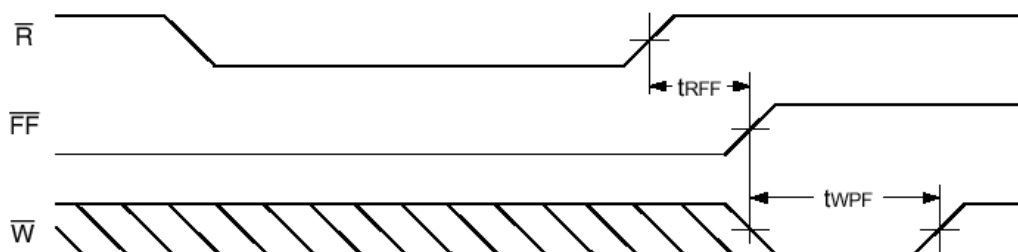

FIGURE 8. HALF-FULL FLAG TIMING

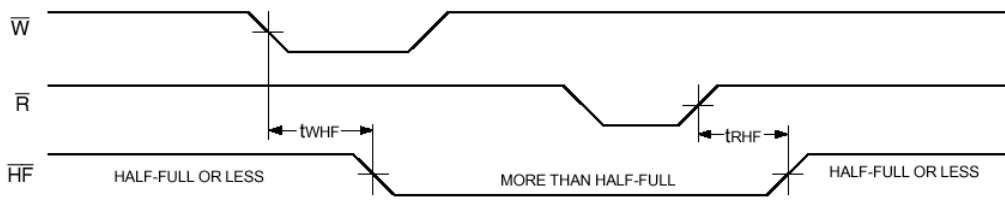

FIGURE 9. EXPANSION OUT

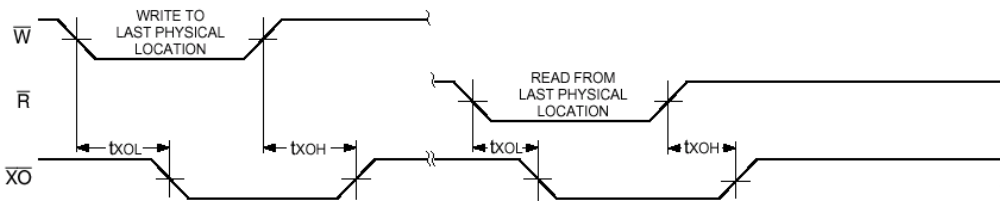

FIGURE 10. EXPANSION IN

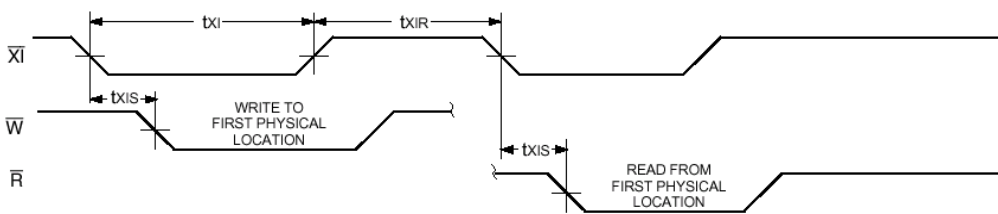

FIGURE 11. READ DATA FLOW FOR THROUGH MODE

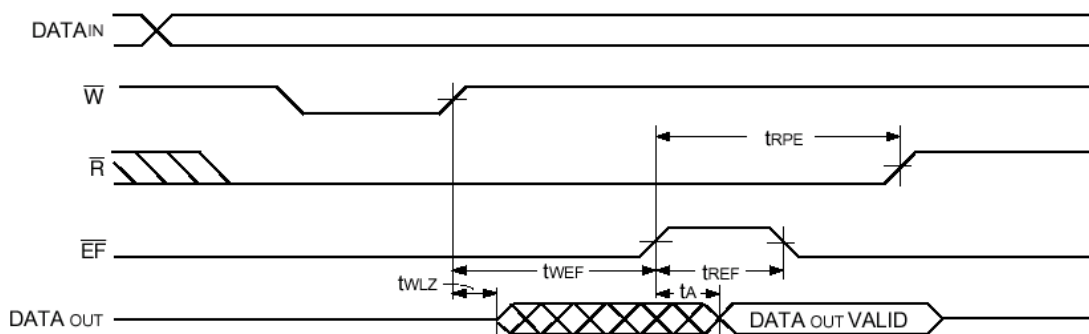
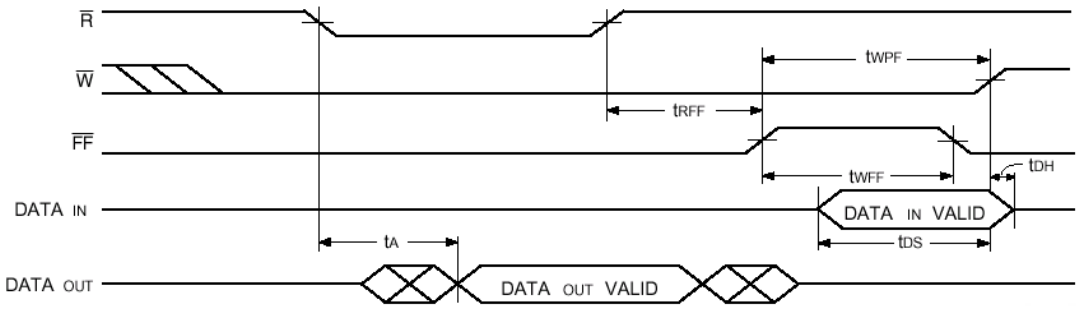
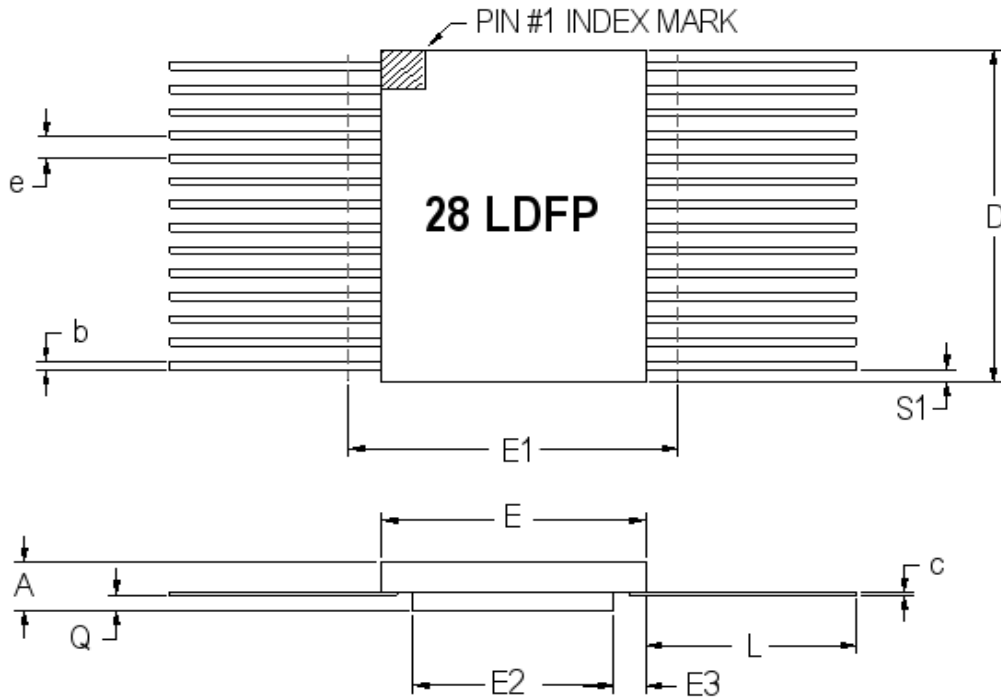

FIGURE 12. WRITE DATA FLOW FOR THROUGH MODE





28 PIN RAD-PAK® FLAT PACKAGE

SYMBOL	DIMENSION		
	MIN	NOM	MAX
A	0.129	0.142	0.155
b	0.015	0.017	0.022
c	0.004	0.005	0.009
D	--	0.720	0.740
E	0.400	0.410	0.420
E1	--	--	0.440
E2	0.180	0.250	--
E3	0.005	0.080	--
e	0.050 BSC		
L	0.390	0.400	0.410
Q	0.021	0.033	0.045
S1	0.005	0.067	--
N	28		

F28-07

Note: All dimensions in inches

# High-Speed Epi-CMOS (16K x 9-Bit) Parallel FIFO

# 7206F

## Important Notice:

These data sheets are created using the chip manufacturers published specifications. Maxwell Technologies verifies functionality by testing key parameters either by 100% testing, sample testing or characterization.

The specifications presented within these data sheets represent the latest and most accurate information available to date. However, these specifications are subject to change without notice and Maxwell Technologies assumes no responsibility for the use of this information.

Maxwell Technologies' products are not authorized for use as critical components in life support devices or systems without express written approval from Maxwell Technologies.

Any claim against Maxwell Technologies must be made within 90 days from the date of shipment from Maxwell Technologies. Maxwell Technologies' liability shall be limited to replacement of defective parts.

# High-Speed Epi-CMOS (16K x 9-Bit) Parallel FIFO

# 7206F

## Product Ordering Options

