



Micro Commercial Components
 21201 Itasca Street Chatsworth
 CA 91311
 Phone: (818) 701-4933
 Fax: (818) 701-4939

MMBD7000

350mW 100Volt Dual Switching Diode

Features

- Low Current Leakage
- Low Cost
- Small Outline Surface Mount Package

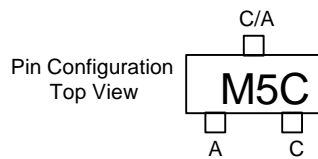

Maximum Ratings

- Operating Temperature: -55°C to +150°C
- Storage Temperature: -55°C to +150°C
- Maximum Thermal Resistance; 357K/W Junction To Ambient

SOT-23

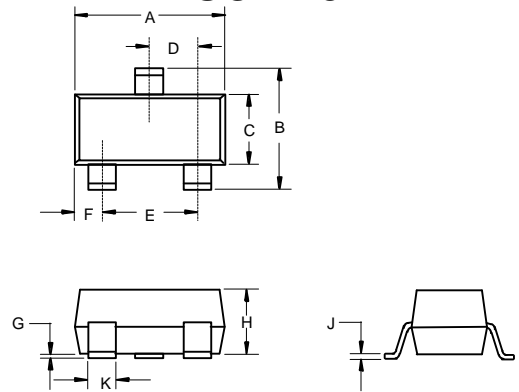

DIM	INCHES		MM		NOTE
	MIN	MAX	MIN	MAX	
A	.110	.120	2.80	3.04	
B	.083	.098	2.10	2.64	
C	.047	.055	1.20	1.40	
D	.035	.041	.89	1.03	
E	.070	.081	1.78	2.05	
F	.018	.024	.45	.60	
G	.0005	.0039	.013	.100	
H	.035	.044	.89	1.12	
J	.003	.007	.085	.180	
K	.015	.020	.37	.51	

Suggested Solder Pad Layout

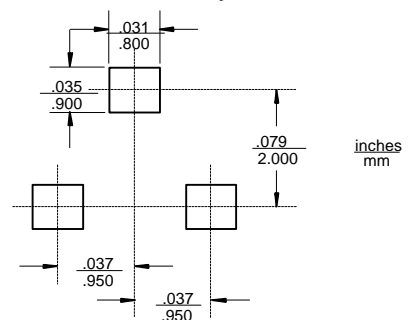

Electrical Characteristics @ 25°C Unless Otherwise Specified

Reverse Voltage	V_R	100V	
Average Rectified Output Current	I_O	150mA	
Power Dissipation	P_{TOT}	350mW	
Peak Forward Surge Current	I_{FSM}	1.0A	$t=1s, \text{Non-Repertitive}$
Maximum Instantaneous Forward Voltage	V_F	820mV	$I_{FM} = 10mA;$ $T_J = 25^\circ C^*$
Maximum DC Reverse Current At Rated DC Blocking Voltage	I_R	1.0 μA 100 μA	$V_R=50Volts$ $T_J = 25^\circ C$ $T_J = 125^\circ C$
Typical Junction Capacitance	C_J	2pF	Measured at 1.0MHz, $V_R=0V$
Reverse Recovery Time	T_{rr}	4nS	$I_F=10mA$ $V_R = 0V$ $R_L=500\Omega$

*Pulse test: Pulse width 300 μsec , Duty cycle 2%

