



Micro Commercial Components  
 21201 Itasca Street Chatsworth  
 CA 91311  
 Phone: (818) 701-4933  
 Fax: (818) 701-4939

# MBR24020 THRU MBR240100

## 240 Amp Schottky Barrier Rectifier 20 to 100 Volts

### Features

- Metal of siliconrectifier, majonty carrier conducton
- Guard ring for transient protection
- Low power loss high efficiency
- High surge capacity, High current capability

### Maximum Ratings

- Operating Temperature: -65°C to +150°C
- Storage Temperature: -65°C to +150°C

MCC Part Number	Maximum Recurrent Peak Reverse Voltage	Maximum RMS Voltage	Maximum DC Blocking Voltage
MBR24020	20V	14V	20V
MBR24030	30V	21V	30V
MBR24035	35V	24.5V	35V
MBR24040	40V	28V	40V
MBR24045	45V	31.5V	45V
MBR24060	60V	42V	60V
MBR24080	80V	56V	80V
MBR240100	100V	70V	100V

### HALF PACK

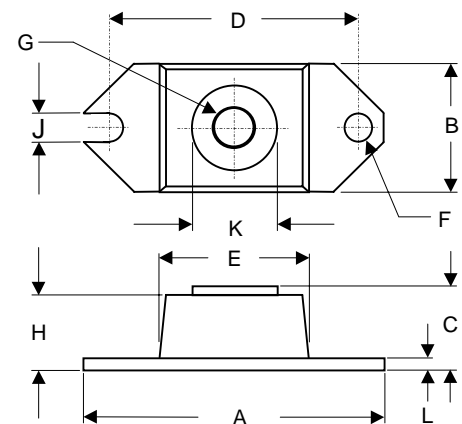

### Electrical Characteristics @ 25°C Unless Otherwise Specified

Average Forward Current	$I_{F(AV)}$	240 A	$T_L = 140^\circ\text{C}$
Peak Forward Surge Current	$I_{FSM}$	3300A	8.3ms, half sine
Maximum Instantaneous Forward Voltage	$V_F$		$I_{FM} = 240.0\text{A}; T_A = 25^\circ\text{C}$
MBR24020-24045		.63 V	
MBR24060		.75 V	
MBR24080-240100		.84 V	
Maximum DC Reverse Current At Rated DC Blocking Voltage	$I_R$	8mA	$T_A = 25^\circ\text{C}$
Typical Junction Capacitance	$C_J$	300pF	Measured at 1.0MHz, $V_R=4.0\text{V}$

DIM	DIMENSIONS				NOTE
	INCH ES		MM		
	MIN	MAX	MIN	MAX	
A	1.520	1.560	38.86	39.62	
B	.725	.775	18.42	19.69	
C	.605	.625	15.37	15.88	
D	1.182	1.192	30.02	30.28	
E	.745	.755	18.92	18.18	
F	.152	.160	3.86	4.06	∅
G	1/4 - 20		UNC - 2B		
H	.570	.580	14.49	14.73	
J	.15	.160	3.96	4.06	
K	.495	.505	12.57	12.83	∅
L	.120	.130	3.05	3.30	

\*Pulse Test: Pulse Width 300µsec, Duty Cycle 1%

Figure 1  
Typical Forward Characteristics

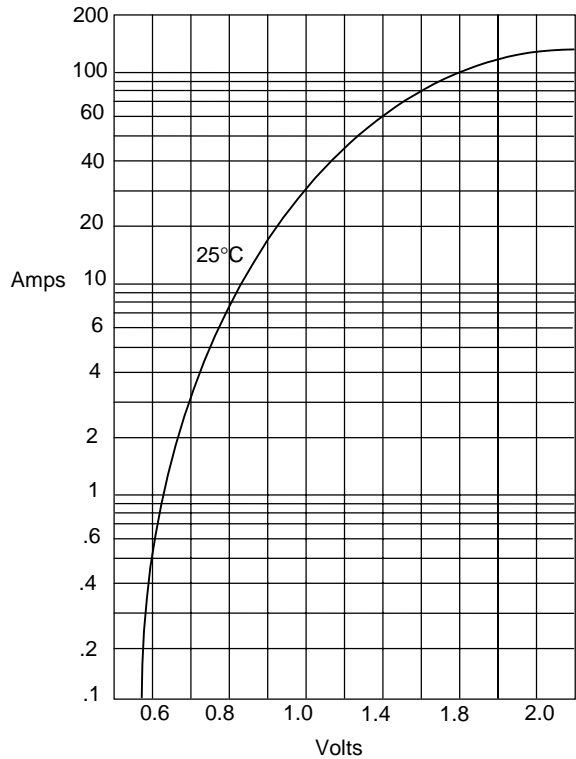

Instantaneous Forward Current - Amperes versus  
Instantaneous Forward Voltage - Volts

Figure 2  
Forward Derating Curve

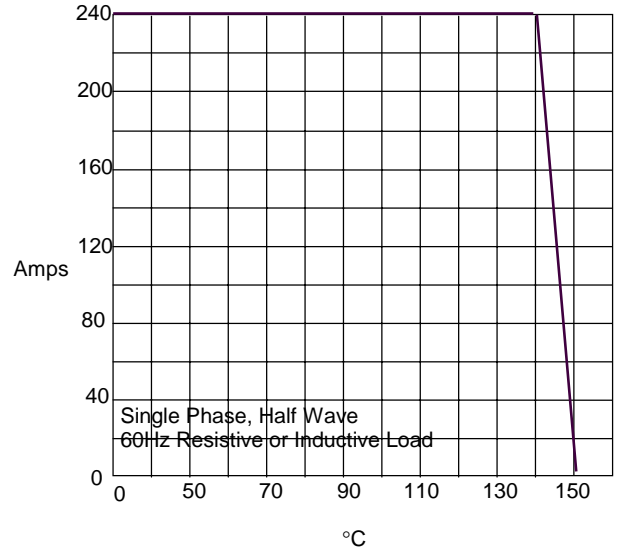

Average Forward Rectified Current - Amperes versus  
Ambient Temperature - °C

Figure 3  
Junction Capacitance

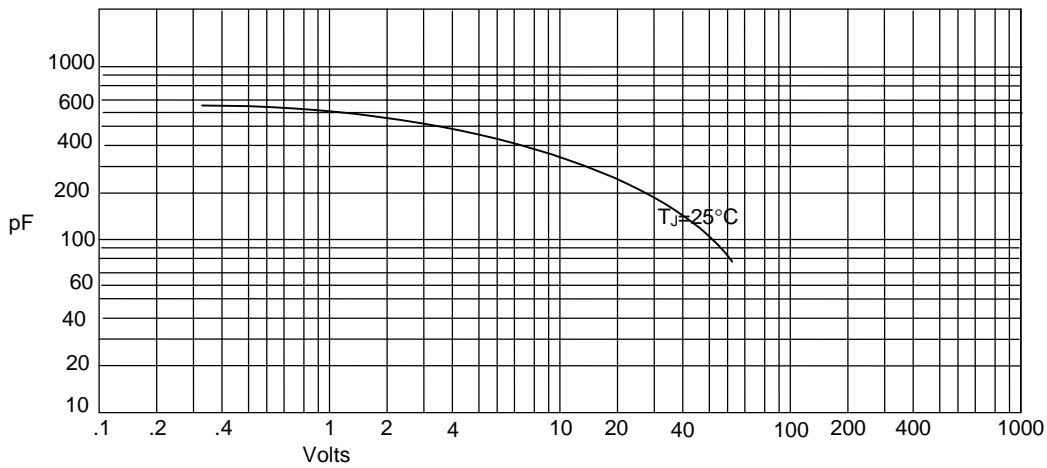

Junction Capacitance - pF versus  
Reverse Voltage - Volts



Figure 4  
Typical Reverse Characteristics

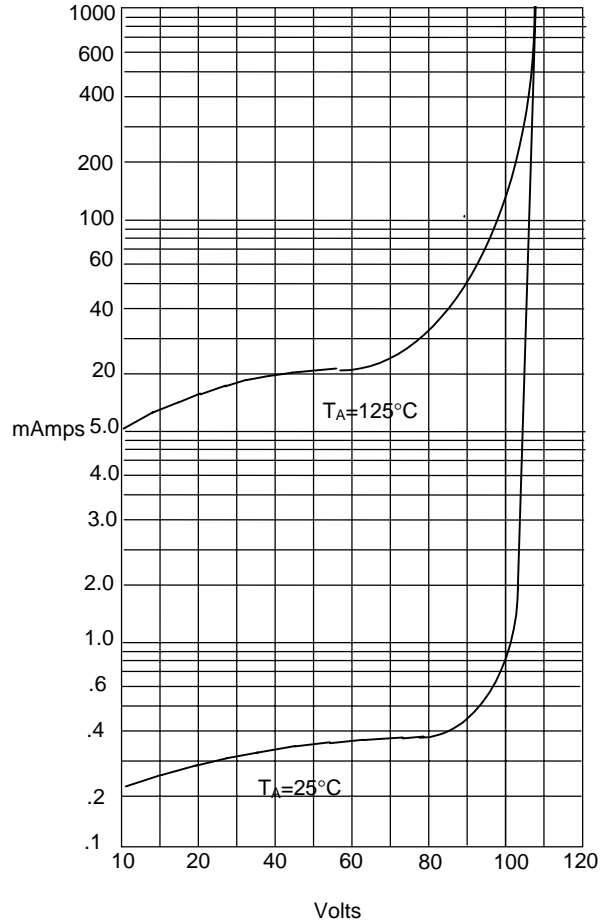

Instantaneous Reverse Leakage Current - MicroAmperes versus  
Percent Of Rated Peak Reverse Voltage - Volts

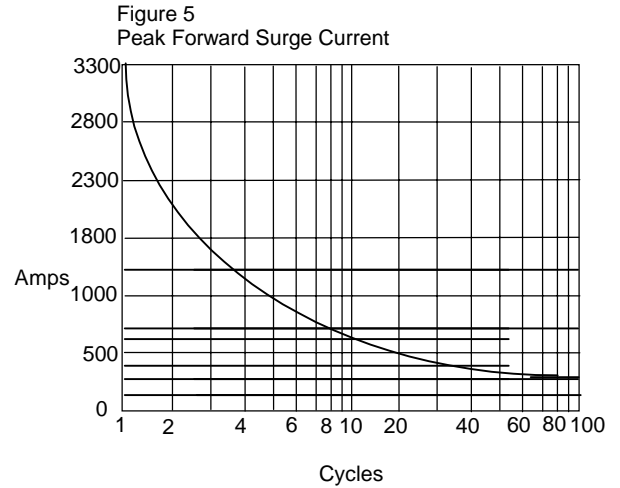

Peak Forward Surge Current - Amperes versus  
Number Of Cycles At 60Hz - Cycles